

1999 OAKLAND COUNTY DIRECTORY



GENREF

JS

261

.02

1999

c.1

WILLIAM CADDELL
County Clerk & Register of Deeds

✓

COUNTY OF OAKLAND MICHIGAN

COUNTY, CITY, TOWNSHIP and VILLAGE OFFICERS

1999

**County Seat
1200 N. TELEGRAPH ROAD
PONTIAC, MICHIGAN 48341**

**TOLL FREE from Holly, Rose, South Lyon,
Novi, Farmington, Southfield,
Royal Oak and Troy
(888) 350-0900**

Visit our web site at: www.co.oakland.mi.us

**L. Brooks Patterson, County Executive
John P. McCulloch, Chairperson, Board of Commissioners
G. William Caddell, County Clerk and Register of Deeds**

**OAKLAND COUNTY RESEARCH LIBRARY
1200 N. TELEGRAPH ROAD DEPT 453
PONTIAC, MICHIGAN 48341-0453**

FRONT COVER:

County Treasurer C. Hugh Dohany and Lynn D. Allen, former County Clerk/ Register were both elected in 1968. This directory is dedicated to the excellent service they have provided over the past 30 years.

The longest serving team of County Clerk/Register and County Treasurer in the State of Michigan and fixtures at the Oakland County Courthouse came to an end in October of 1998 with the retirement of Lynn D. Allen.

Treasurer C. Hugh Dohany continues to be the longest serving County Treasurer in Michigan and is now teamed with G. William Caddell, our new County Clerk/Register of Deeds.

(Pictured: C. Hugh Dohany, County Treasurer and Lynn D. Allen, County Clerk/Register)

TABLE OF CONTENTS

Census	30
Equalized Valuation	31
History of Oakland County	35 & 36
Organizational Chart — County	34

BOARD OF COMMISSIONERS

Caucus Chairperson, Majority and Minority	10
Chairperson, Vice-Chairperson	10, 11 & 13
Committees	11
Members	10 & 11

COUNTY OFFICERS

Airports	12
Animal Control Division	12
Arts, Culture & Film	12, 14 & 15
Assignment Clerk (<i>See Circuit Court Administrator</i>)	12
Building Authority	12
Building Safety	12
Canvassers, Board of	12
Central Services (<i>See Executive, County</i>)	14 & 15
Children's Services (<i>See Probate Court</i>)	17
Children's Village	12
Circuit Court Administrator	12
Circuit Court Judges	7 & 12
Clerk/Register of Deeds	12
Community and Minority Affairs	13 & 15
Community Development	13
Community Mental Health Authority	13 & 36
Conservation District, Oakland County	13
Corporation Counsel	13, 14 & 15
Court Administrator (<i>See Circuit Court</i>)	12
Deferred Compensation Board	13
District Court Judges	8 & 9
Drain Commissioner	13
Election Commission	13
Election Scheduling Committee	14
Emergency Management Unit	14
Employees Retirement Commission	14
Equalization Division	14
Executive, County	14 & 15
Facilities Management, Department of	14 & 15
Family Independence Agency	15

TABLE OF CONTENTS (continued)

Food Service Appeal Board	15
Friend of the Court	15
Health Officer	15
Historical Commission	15
Human Services (<i>See Executive, County</i>)	14 & 15
Huron Clinton Metropolitan Authority	15
Information Technology (<i>See Executive, County</i>)	14 & 15
Jury Commissioners	16
Juvenile Court (<i>See Probate Court</i>)	17
Law Library	16
Library Board	16
Library for the Blind and Physically Handicapped	16
Management and Budget (<i>See Executive, County</i>)	14 & 15
Media and Communications (<i>See Executive, County</i>)	14 & 15
Medical Care Facility	16
Medical Examiner	16
Mental Health Services (<i>See Community Mental Health</i>)	13 & 36
MSU Extension	16
Parks and Recreation Commission	16, 17, 26, 27 & 28
Personnel (<i>See Executive, County</i>)	14 & 15
Personnel Appeal Board	17
Planning and Economic Development Services	17 & 32
Probate Court	17
Probate Court Judges	7
Probation Department, Adult	17
Prosecuting Attorney	17 & 18
Public Administrators	18
Public Services (<i>See Executive, County</i>)	14 & 15
Research Library	16
Risk Management and Safety	14, 15 & 18
Road Commission	18, 19 & 37
Sanitary Code Appeal Board	19
Schools, Superintendent of	19
Sheriff	19
Social Services (<i>See Family Independence Agency</i>)	15
Solid Waste Planning (<i>See Facilities Management</i>)	15
Transportation Authority	19
Treasurer	19
Veterans Services	20
Water and Sewage Operations (<i>See Drain Commissioner</i>)	13

TABLE OF CONTENTS (continued)

MAPS

Board of Commissioners	24 & 25
Oakland County	29
Oakland County Parks	26
Oakland County Service Center Campus Map	33
State Representative	23
State Senate	22
U.S. Congressional	21

NATIONAL OFFICERS

United States Officials	6
United States Representatives	6
United States Senators	6

STATE OFFICERS

Appeals Court	7
Officials	6
Representatives	6
Senators	6
Supreme Court	7

CITIES

Auburn Hills	38
Berkley	38
Birmingham	39
Bloomfield Hills	39
Clarkston	40
Clawson	40
Farmington	41
Farmington Hills	41
Ferndale	42
Hazel Park	42
Huntington Woods	43
Keego Harbor	43
Lake Angelus	44
Lathrup Village	44
Madison Heights	45
Northville	45
Novi	46
Oak Park	46
Orchard Lake Village	47
Pleasant Ridge	47
Pontiac	48
Rochester	48

TABLE OF CONTENTS (continued)

Rochester Hills	49
Royal Oak	49
Southfield	50
South Lyon	50
Sylvan Lake	51
Troy	51
Walled Lake	52
Wixom	52

TOWNSHIPS

Addison	53
Bloomfield	53
Brandon	54
Commerce	54
Groveland	55
Highland	55
Holly	56
Independence	56
Lyon	57
Milford	57
Novi	58
Oakland	58
Orion	59
Oxford	59
Rose	60
Royal Oak	60
Southfield	61
Springfield	61
Waterford	62
West Bloomfield	62
White Lake	63

VILLAGES

Beverly Hills	64
Bingham Farms	64
Franklin	64
Holly	64
Lake Orion	64
Leonard	65
Milford	65
Ortonville	65
Oxford	65
Wolverine Lake	65

NATIONAL OFFICERS

President of the United States Bill Clinton
 Vice President Al Gore

Cabinet Members:

Secretary of Agriculture Dan Glickman
 Attorney General Janet Reno
 Secretary of Commerce William M. Daley
 Secretary of Defense William S. Cohen
 Secretary of Education Richard W. Riley
 Secretary of Energy Bill Richardson
 Secretary of Health and Human Services Donna E. Shalala
 Secretary of Housing and Urban Development Andrew M. Cuomo
 Secretary of the Interior Bruce Babbitt
 Secretary of Labor Alexis M. Herman
 Secretary of State Madeleine K. Albright
 Secretary of Transportation Rodney E. Slater
 Secretary of Treasury Robert E. Rubin
 Secretary of Veterans Affairs Togo West

U.S. Senator Spencer Abraham (R)
 U.S. Senator Carl Levin (D)

U.S. Representatives:

8th District Debbie Stabenow, Lansing (D)
 9th District Dale E. Kildee, Flint (D)
 11th District Joe Knollenberg, Bloomfield Hills (R)
 12th District Sander Levin, Royal Oak (D)

STATE OFFICERS

Governor John Engler (R)
 Lieutenant Governor Dick Posthumus (R)
 Secretary of State Candice S. Miller (R)
 State Treasurer Mark Murray
 Attorney General Jennifer M. Granholm (D)

STATE SENATORS

State Capitol, P.O. Box 30036, Lansing, MI 48909

13th District Vacancy
 14th District Gary Peters, Bloomfield Township (D)
 15th District Willis Bullard, Jr., Highland (R)
 16th District Mat Dunaskiss, Lake Orion (R)
 28th District John D. Cherry, Jr., Clio (D)

STATE REPRESENTATIVES

State Capitol, P.O. Box 30014, Lansing, MI 48909

34th District Dave Woodward, Madison Heights (D)
 35th District Gilda Z. Jacobs, Huntington Woods (D)
 36th District Nancy L. Quarles, Southfield (D)
 37th District Andrew Raczkowski, Farmington Hills (R)
 38th District Nancy C. Cassis, Novi (R)
 39th District Marc Shulman, West Bloomfield (R)
 40th District Patricia A.K. Godchaux, Birmingham (R)
 41st District John Pappageorge, Troy (R)
 42nd District Robert Gosselin, Troy (R)
 43rd District Hubert Price, Jr., Pontiac (D)
 44th District Mike Kowall, White Lake (R)
 45th District Mike Bishop, Rochester (R)
 46th District Ruth Johnson, Holly (R)

MICHIGAN SUPREME COURT
Law Building, 2nd Floor, Lansing, MI 48933

Elizabeth A. Weaver, Chief Justice
 James H. Brickley
 Michael F. Cavanagh
 Maura D. Corrigan
 Marilyn Kelly
 Clifford W. Taylor
 Robert P. Young, Jr.

COURT OF APPEALS JUDGES
DISTRICT 2

27777 Franklin Road
Suite 760
Southfield, MI 48034

Mark J. Cavanagh
 Martin M. Doctoroff
 Hilda R. Gage
 Kathleen Jansen
 Michael J. Kelly
 Henry W. Saad

CIRCUIT COURT JUDGES

1200 N. Telegraph Road, Pontiac, MI 48341

Steven N. Andrews	858-0360
David F. Breck	858-0335
Jessica R. Cooper	858-0337
Alice L. Gilbert	975-4250
Nanci J. Grant	858-0358
Barry L. Howard	858-5284
Richard D. Kuhn	858-0332
John J. McDonald	858-0342
Fred M. Mester	858-0355
Denise K. Langford Morris	858-0363
Rudy J. Nichols	452-2000
Colleen A. O'Brien	858-0368
Wendy Potts	858-0365
Gene Schnelz	858-5280
Edward Sosnick	858-0340
Deborah G. Tyner	452-2005
Joan E. Young	858-5282

PROBATE COURT JUDGES

1200 N. Telegraph Road, Pontiac, MI 48341

ESTATES FAX (248) 452-2016

Barry M. Grant	FAX (248) 975-9780	858-0286
Linda S. Hallmark	FAX (248) 452-5194	858-0289
Eugene Arthur Moore	FAX (248) 452-9398	858-0250
Sandra G. Silver	FAX (248) 858-1506	858-0240

DISTRICT COURT JUDGES, OAKLAND COUNTY, MICHIGAN

District	Name and Address	Telephone	Geographical Area
35th	RONALD W. LOWE JOHN E. MacDONALD 660 Plymouth Road Plymouth 48170-1891	(734) 459-4740	Oakland County portion of Northville City
43rd	JOSEPH LONGO 305 E. Nine Mile Road Ferndale 48220	(248) 547-8700	Cities of Ferndale, Hazel Park and Madison Heights
	KEITH P. HUNT 43 E. Nine Mile Road Hazel Park 48030	(248) 547-3034	
	ROBERT J. TURNER 200 W. Thirteen Mile Road Madison Heights 48071 ...	(248) 583-1800	
44th	TERRENCE H. BRENNAN DANIEL SAWICKI 211 Williams Street Royal Oak 48068	(248) 546-7780	City of Royal Oak
45A	WILLIAM R. SAUER 3338 Coolidge Highway Berkley 48072 Civil Division	(248) 544-3301 (248) 544-3300	City of Berkley
45B	MARVIN F. FRANKEL BENJAMIN J. FRIEDMAN 13600 Oak Park Boulevard Oak Park 48237	(248) 691-7440	Cities of Huntington Woods, Oak Park, Pleasant Ridge and Royal Oak Township
46th	STEPHEN C. COOPER BRYAN H. LEVY SUSAN M. MOISEEV 26000 Evergreen Road Southfield 48076 Civil Division	(248) 354-9370 (248) 354-9368 (248) 354-9360	Cities of Lathrup Village, Southfield; Southfield Township; Villages of Beverly Hills, Bingham Farms and Franklin
47th	FREDERICK L. HARRIS MARLA E. PARKER 32795 W. Ten Mile Road Farmington 48336	(248) 477-5630 General Information Ext. 110 Civil Division Ext. 119 Probation Ext. 137 Traffic/Criminal Ext. 123 Automated Traffic Fine Schedule	Cities of Farmington and Farmington Hills
48th	EDWARD AVADENKA GUS CIFELLI KIMBERLY SMALL 4280 Telegraph Road P.O. Box 3200 Bloomfield Hills 48302-3200	(248) 647-1141	Cities of Birmingham, Bloomfield Hills, Keego Harbor, Orchard Lake and Sylvan Lake; Townships of Bloomfield and West Bloomfield

DISTRICT COURT JUDGES, OAKLAND COUNTY, MICHIGAN

District	Name and Address	Telephone	Geographical Area
50th	LEO BOWMAN CHRISTOPHER C. BROWN PRESTON G. THOMAS WILLIAM WATERMAN 70 N. Saginaw Street Pontiac 48342	Civil Division (248) 857-8090 Criminal Division (248) 857-8027 Probation Department (248) 857-8091 Traffic Department (248) 857-8078	City of Pontiac
51st	KENNETH H. HEMPSTEAD PHYLLIS C. McMILLEN 5100 Civic Center Drive Waterford 48329	Traffic (248) 674-4773 Civil/Criminal/Probation (248) 674-4655	Township of Waterford
52nd-1st Div.	MICHAEL BATCHIK BRIAN W. MacKENZIE DENNIS N. POWERS 48150 Grand River Avenue Novi 48374-1222	Civil Division (248) 305-6080 Criminal Division (248) 305-6460 Probation Division (248) 305-6144 Traffic Division (248) 305-6511	Cities of Novi, South Lyon, Walled Lake and Wixom; Townships of Commerce, Highland, Lyon, Milford, Novi, Rose and White Lake; Villages of Milford and Wolverine Lake
52nd-2nd Div.	GERALD E. McNALLY 5850 Lorac Clarkston 48346	Civil Division (248) 625-4994 Criminal Division (248) 625-4888 Violations Bureau (248) 625-4880 Probation Division (248) 625-5957	City of Clarkston; Townships of Brandon, Groveland, Holly, Independence and Springfield; Villages of Holly and Ortonville
52nd-3rd Div.	RALPH H. NELSON JULIE A. NICHOLSON JAMES P. SHEEHY 135 Barclay Circle Rochester Hills 48307	(248) 853-5553 Probation Department (248) 852-8263	Cities of Auburn Hills, Lake Angelus, Rochester and Rochester Hills; Townships of Addison, Oakland, Orion and Oxford; Villages of Lake Orion, Leonard and Oxford
52nd-4th Div.	WILLIAM E. BOLLE DENNIS C. DRURY MICHAEL A. MARTONE 500 West Big Beaver Road Troy 48084	Civil Division (248) 528-0404 Traffic/Criminal Division (248) 528-0400	Cities of Clawson and Troy

1999-2000 OAKLAND COUNTY BOARD OF COMMISSIONERS

Commissioners' Office Phone Number: (248) 858-0100

Name and Address	District Number	
FRAN AMOS (R) 4079 Aquarina Waterford 48329	5	E-mail: amos@oakland.edu or amosf@co.oakland.mi.us Voice & FAX: (248) 673-8394
MICHELLE FRIEDMAN APPEL (D) 10064 Nadine Huntington Woods 48070	23	Home: (248) 547-0794 Work: (248) 647-8383
BRENDA A. CAUSEY-MITCHELL (D) 27 Miami Road Pontiac 48341	6	(248) 338-0171
RONALD COLASANTI (R) 468 South Milford Road Highland 48357	10	(248) 887-0012
ERIC COLEMAN (D), Caucus Chairperson 18141 Westhampton Southfield 48075	21	E-mail: colemane@co.oakland.mi.us (248) 569-4599
DAN DEVINE (R), Caucus Chairperson 2146 Lost Tree Way Bloomfield Hills 48304	14	Home: (248) 338-2165
NANCY DINGELDEY (R) 2220 Euna Road Wixom 48393	11	E-mail: dingeldeyn@co.oakland.mi.us Voice & FAX (248) 669-5921
SUE ANN DOUGLAS (R) 1228 Main Street Rochester 48307	8	E-mail: douglas@ees.eesc.com (248) 651-1255
DAVID N. GALLOWAY (R) 1200 N. Telegraph Road Pontiac 48341-0470	2	(248) 858-0100
JOHN P. GARFIELD (R) 1347 Ruby Rochester Hills 48309	9	E-mail: JGarfield@Compuserve.com Business & FAX: (248) 853-7410 Home: (248) 852-7199
VINCENT GREGORY (D) 29501 Red Leaf Drive Southfield 48076	20	E-mail: VGregroy@aol.com (248) 559-1032
DONALD W. JENSEN (R) 1233 Maryland Boulevard Birmingham 48009	15	E-mail: jensend@co.oakland.mi.us (248) 647-5830
THOMAS A. LAW (R) 6766 Glenway Drive West Bloomfield 48322	13	(248) 855-2505
JOHN P. McCULLOCH (R), Chairperson 1609 Cedar Hill Drive Royal Oak 48067	22	(248) 398-7527
RUEL E. McPHERSON (D) 23439 Davey Hazel Park 48030	25	E-mail: CoCom25@worldnet.att.net (248) 545-7061

1999-2000 OAKLAND COUNTY BOARD OF COMMISSIONERS

Name and Address	District Number	
TIM MELTON (D) 2285 Snellbrook Auburn Hills 48326	7	E-mail: TimMelton@aol.com (248) 377-3823
FRANK H. MILLARD, JR. (R) 6060 Dixie Highway, Suite A Clarkston 48346	4	(248) 623-3280
DAVID L. MOFFITT (R) 37282 Fox Glen Farmington Hills 48331	18	FAX: (248) 644-0019 Voice: (248) 644-0880 (248) 788-3729
LAWRENCE A. OBRECHT (R), Vice-Chairperson 1437 Nakomis Lake Orion 48362	3	FAX: (248) 693-8232 (248) 693-8231
CHARLES E. PALMER (R) 459 John M Clawson 48017	16	FAX: (248) 435-4477 (248) 435-9391
WILLIAM R. PATTERSON (R) 435 Hillcrest Court Oxford 48371	1	(248) 628-2077
KAY SCHMID (R) 28105 Summit Drive Novi 48377	17	FAX: (248) 349-1404 (248) 349-0099
TERRY SEVER (R) 34436 Beechwood Drive Farmington Hills 48335	19	(248) 615-9094
GEORGE W. SUAREZ (D) 1735 Moulin Madison Heights 48071	24	(248) 414-7396
SHELLEY GOODMAN TAUB (R) 1959 Shore Hill Drive Bloomfield 48302	12	FAX: (248) 858-8866 (248) 858-8870

OAKLAND COUNTY BOARD OF COMMISSIONERS COMMITTEES FOR 1999

(First named is Chairperson,
second named is Vice-Chairperson,
third named is minority Vice-Chairperson)

Finance	Douglas, Jensen, Appel, Palmer, Obrecht, Taub, Millard, Amos, Coleman, Causey-Mitchell
General Government	Taub, Dingeldey, McPherson, Law, Garfield, Patterson, Sever, Appel, Melton
Personnel	Law, Devine, Gregory, Moffitt, Colasanti, Galloway, Suarez
Planning and Building	Palmer, Amos, Suarez, Jensen, Schmid, Garfield, Colasanti, Sever, Gregory, Melton
Public Services	Millard, Moffitt, Causey-Mitchell, Schmid, Dingeldey, Galloway, Patterson, McPherson

COUNTY OFFICERS

Airport Committee, County	Dan Devine, Chairperson William R. Patterson, Vice-Chairperson Vincent Gregory, Secretary Karl W. Randall, Manager of Aviation FAX (248) 666-3341 Oakland County International Airport 666-3900 6500 Highland Road, Waterford 48327-1649 Oakland/Troy Airport 288-6100 2672 Industrial Row, Troy 48084-7036
Animal Control Division (K)	Sandra L. Gay, Manager 391-0278 Lt. Al Arnold, Kennel Supervisor 391-4100 Lt. Ron Leake, Road Supervisor 391-4102 Joanie Toole, Office Supervisor 391-0286
Arts, Culture & Film (A)	Nancy Hayden, Director 858-0415 Oakland County Regional Regranting Agency
Building Authority (A)	Ken Strobel, Chairperson Tamara Vanwormer-Tazzia, Vice-Chairperson Thomas Fockler, Secretary L. Brooks Patterson, County Executive C. Hugh Dohany, Treasurer Information 858-0163
Building Safety (G)	858-0931
Canvassers, Board of (A)	Georgia Moore Elsie Reuter C. Elaine Skarritt Dorothy White G. William Caddell, Clerk 858-0561
Children's Village (A)	Michael K. Worrell, Manager 858-1164 Peter D. Balzerini, Administrator, Intake Treatment Services 858-1160 Patricia A. Lahar, Administrator, Residential Treatment Services 858-1162 General Information 858-1150
Circuit Court Administrator - Judicial Assistant (A)	Judith K. Cunningham 858-0349 Kevin M. Oeffner, Deputy 858-0347 Mary Jane Rigonan, Assignment Clerk 858-0350 Becky Young, Jury Clerk 858-0029
*Circuit Court Judges (A)	(See Page 7)
*Clerk/Register of Deeds (A) ..	G. William Caddell 858-0561 Patrick D. Campbell, Deputy Clerk/Register 858-0560 Stephanie Schroeder, Chief Deputy Clerk 858-0586 Clerk's Office Legal Records 858-0582 Vital Statistics 858-0571 Assumed Names 858-0568 Sue Payne, Chief Deputy Register 858-0610 Register of Deeds 858-0605 Plat Engineer 858-1447 Mary Jo Hammond, Director of Elections 858-0563 Election Division 858-0564

*Elected Officials

*Commissioners, Board of (A) ..	John P. McCulloch, Chairperson Lawrence A. Obrecht, Vice-Chairperson G. William Caddell, Clerk Suzette Vogt, Chief of Administration 858-0100 Joellen Perlman, Director, Program Evaluation 858-1701
Community and Minority Affairs (A)	Richard E. Williams, Jr., Director 858-1047
Community Development (A)	Karry L. Rieth, Manager 858-0493
Community Mental Health Authority (A)	
Board Members:	
	Fran Amos, Chairperson
	JoAnne Holbert, Vice-Chairperson
	Calvin J. Lippitt, Secretary
	Harold Bay Janet Stack-Miller
	Jan Dolan Judith Summers
	Steven C. Hill Vacancy
	Clifford Johnson Sandra M. Lindsey, M.S.W., A.C.S.W.,
	John P. McCulloch Executive Director 858-1221
	Charles E. Palmer Michael O'Hair, Deputy Director 858-1209
Conservation District, Oakland County	Robert Long, Chairperson 2891 Dixie Highway, Waterford 48328 673-4496
Corporation Counsel (A)	Gerald D. Poisson 858-0550 Jody M. McLeod, Deputy Corporation Counsel Michael D. Blaszczyk, Assistant Joseph W. Colaianne, Assistant Jeffrey M. Kaelin, Assistant William G. Pierson, Assistant Ahmad M. Roby, Assistant John F. Ross, Assistant Jody S. Schaffer, Assistant Julie L. Secontine, Assistant Donald F. Slavin, Assistant
Deferred Compensation Board (A)	Robert Daddow, Chairperson Gerald D. Poisson, Vice-Chairperson Judy Eaton John P. McCulloch C. Hugh Dohany, Secretary-Treasurer 858-0623 Douglas J. Williams, Plan Administrator 858-0497
*Drain Commissioner (G) (I) ...	George W. Kuhn 858-0958 James E. Porter, Chief Deputy Douglas A. Buchholz, Deputy and Manager, Operations and Maintenance Division William E. Klockow, Deputy and Manager, Engineering and Construction Division Joseph P. Kozma, Chief Engineer
Election Commission (A)	Eugene Arthur Moore, Chairperson G. William Caddell, Clerk-Secretary C. Hugh Dohany, Treasurer

*Elected Officials

Election Scheduling Committee	Sherrie English, Bloomfield Hills School Board Member Kathryn A. Dornan, Farmington Hills City Clerk William Brian, Highland Township Clerk G. William Caddell, Clerk	858-0561
Emergency Management Unit (A)	Gail A. Novak, Chief	858-5300
Employees Retirement Commission (A)	Dennis L. Murphy, Chairperson Paul Allberry, Vice-Chairperson	
Members:		
Margaret Birch	James H. VanLeuven, Jr.	
Sue Ann Douglas	C. Hugh Dohany, Treasurer and Member	
John P. McCulloch	Douglas J. Williams, Secretary	
Shane Murphy	Gerald D. Poisson, Corporation Counsel	
L. Brooks Patterson	858-0623
Equalization Division (L)	Robert O. Vandermark, Manager	858-0775
	Phillip Bertolini, Administrator	858-0754
	Real Property Information	858-0776
	Personal Property Information	858-0757
	Tax Descriptions	858-0762
*Executive, County (A)	L. Brooks Patterson	858-0484
	Kenneth Rogers, Deputy County Executive	858-0485
	Douglas J. Williams, Deputy County Executive	858-0497
	Jean Chamberlain, South End Government Liaison	858-1685
	Delores Conaway, Coordinator, Executive Office	858-5400
	Robert J. Daddow, Director, Management and Budget	858-0490
	Jeffrey Pardee, Deputy Director, Management and Budget	858-0487
	Robert E. Dustman, Media and Communications Officer	858-1048
	Judy Eaton, Director, Personnel	858-0537
	Stanley Fayne, Risk Manager	858-1014
	Thomas J. Gordon, Ph.D., Director, Human Services	858-1293
	Nancy Hayden, Director, Arts, Culture & Film	858-0415
	Jeffrey A. Kaczmarek, Director, Community and Economic Development	858-0278
	John Mahoney, Director, Information Technology	858-0815
	Gerald D. Poisson, Corporation Counsel	858-0550
	David W. Ross, Director, Facilities Management	858-1208
	Carmen V. Talbot, State of MI Government Liaison	858-1422
	J. David VanderVeen, Director, Central Services	858-0516

*Elected Officials

(County Executive continued on next page)

(County Executive continued)	Richard E. Williams, Jr., Director, Community and Minority Affairs	858-1047
	Michael W. Zehnder, Director, Public Services	858-1074
Facilities Management, Department of (G)	David W. Ross, Director	858-0160
	Paul N. Hunter, Manager, Facilities Engineering	858-0125
	Richard C. Johnston, Manager - Facilities, Maintenance and Operations Division	858-0169
	Roger J. Smith, P.E., Manager, Solid Waste Planning	858-1352
Family Independence Agency (N)	Gale R. Colwell, Board Chairwoman Clarence D. Green, Ph.D., Board Vice-Chairman Vacancy, Board Member Gerald W. Hall, Director	975-4801
	Cynthia D. Travis, Deputy Director	975-4810
	District I Billy Holland	975-5445
	District II Donald Dersnah, Manager	583-8700
	District III Richard Holmes, Manager	669-7600
	District IV Dorothy Butler, Acting Manager	975-5200
	District V Melvin Kaufman, Manager	975-4820
Food Service Appeal Board	Dr. Val C. Vangieson, Chairperson Edward P. O'Rourke, Vice-Chairperson Nancy Dingeldey Ruel E. McPherson Rosemarie Rowney Theodore Spehar Ronald L. Grimes, Administrator, Environmental Health Services	858-1320
Friend of the Court (M)	Joseph G. Salamone	858-0424
	Kathleen A. Cox, Chief Assistant	
Health Officer (A) (E) (F)	Rosemarie Rowney, Manager	858-1410
Historical Commission	Jennifer Radcliff, Chairperson Barbara Randau, Vice-Chairperson Elsie August Kay Backus Jean Milton Daniel Prevost Paul Stupka Bradford Wilson	
Huron Clinton Metropolitan Authority - Commission	Oakland Wayne Washtenaw Governor App. Governor App. Macomb Livingston Frank J. Sudek, Director Administrative Office: 13000 High Ridge Dr., P.O. Box 2001 Brighton, MI 48116-8001 (810) 227-2757 or Toll Free No. 1-800-47-PARKS	- James Clarkson, Chairperson - William E. Kreger, Vice-Chairperson - Robert W. Marans, Treasurer - John C. Hertel - Maxine L. Perry - Thomas S. Welsh - James Young

Jury Commissioners (A)	Nanig Manoukian	858-0593
	Arlene Schell	858-5305
	Flora Whan	858-0378
Library Board (A)	C. Hugh Dohany, Chairperson	
	Robert Gaylor, Secretary	
	Hon. Steven Andrews Dr. James Redmond	
	John Chambers Robert Tera	
	Donald W. Jensen	
	Phyllis Jose, Director,	
	Library Services	858-0380
	Research Library	858-0738
	Law Library	858-0012
	Library for the Blind and	
	Physically Handicapped	858-5050
	TDD	452-2247
Medical Care Facility (A)	Shirla F. Kugler, Manager	
	Cindy Davis, Assistant Administrator/Admissions	
	Candace Otte-Ingram, R.N., Nursing Director	
	Information	858-1415
Medical Examiner (A)	Ljubisa J. Dragovic, M.D.,	
	Chief Forensic Pathologist/Medical Examiner	858-4046
	Robert Gerds, Administrator	858-4045
	Kanubhai Virani, M.D.,	
	Deputy Chief Forensic Pathologist	858-4044
	Philip Predmore, Ph.D., Chief Toxicologist	858-4042
	Bernardino Pacris, M.D.,	
	Deputy Forensic Pathologist	858-1494
	Ruben Ortiz-Reyes, M.D.,	
	Deputy Forensic Pathologist	452-9390
	Waldemar Palutke, M.D.,	
	Deputy Forensic Pathologist	452-9390
	Office Information	858-5097
MSU Extension -		
Oakland County (A)	Wayne H. Nierman, Ph.D.,	
	County Extension Director	858-0885
	Greg Patchan, Horticulture	858-0887
	Lois Thieleke, Home Economics	858-0897
	Sylvia Treitman, Food and Nutrition	858-0904
	Thomas Schneider, 4-H Youth Programs	858-0889
	Carol Lenchek, Gypsy Moth Suppression	858-5198
	Office Information	858-0880
	Garden Center/Hotline	858-0902
	Food & Nutrition Hotline	858-0904
	Larry Davis, Community Development	858-0895
	Larry Ruetz, Groundwater/Freshwater	858-0895
	Joanne Crane, 4-H Youth Agent	858-1509
	Christy Hicks, 4-H Youth Agent	858-0890
	Martha Ferguson, Extension Program Coordinator	858-0900
Parks and Recreation		
Commission (D)	Pecky D. Lewis, Jr., Chairman	
	Richard Skarritt, Vice-Chairman	
	Richard D. Kuhn, Jr., Secretary	
	Eric Coleman	

(Parks and Recreation Commission continued on next page)

(Parks and Recreation

<i>Commission continued)</i>	Fred Korzon	
	George W. Kuhn	
	Thomas A. Law	
	Nancy McConnell	
	Charles E. Palmer	
	J. David VanderVeen	
	Ralph Richard, Executive Officer	858-0906
	Jon J. Kipke, Assistant Manager	
Personnel Appeal Board	Dan Devine, Jr., Chairperson	
	Donald W. Jensen, Vice-Chairperson	
	Anna Devers	
	Jean Milton	
	Gerald Reeves	
Planning and Economic		
Development Services (A)	Daniel P. Hunter, Manager	858-0720
Oakland County Economic		
Development Corporation ...	Dennis King, Chairperson	
	Rebecca Sorensen, Vice-Chairperson	
	Robert Shimmin, Secretary	
	Jeffrey A. Kaczmarek, Assistant Secretary	
	C. Hugh Dohany, Treasurer	
Oakland County Business		
Finance Corporation	Walter Reebel, Chairperson	
	David Ellis, President	
	John O'Brien, Vice-President	
	Jeffrey A. Kaczmarek, Secretary	
	C. Hugh Dohany, Treasurer	
Probate Court (A) (B) (F)	Lisa Symula, Probate Register	858-0282
	Robert L. Bingham,	
	Family Division Administrator/Juvenile Register ..	858-0950
	William P. Bartlam, Deputy Court Administrator,	
	Judicial Support	858-0977
	John L. Cooperrider, Deputy Court Administrator,	
	Administrative Support	858-0256
	Pamela Howitt, Ph.D., Deputy Court Administrator,	
	Court Services	858-0247
	Estates and Mental Health Unit,	
	General Information	858-0260
	Juvenile and Adoption Unit,	
	General Information	858-0112
Probation Department,		
Adult (A) (B)	Kenneth J. Aud,	
	Chief Probation Officer	858-0300
*Prosecuting Attorney (A) (H)	David G. Gorcyca	858-0656
	John N. O'Brien II, Chief Deputy Prosecutor	858-0642
	James Halushka, Director of Warrants	
	and Investigations	858-0688
	Ronald Covault, Director of Litigation	858-0671
	Mary Larkin, Director of Administration	858-5558

*Elected Officials

ASSISTANT PROSECUTORS

David Case, Family Support	858-5622	Jason Pernick, Warrants	858-5533
Lisa Halushka, Juvenile Court	858-0226	Paul Stablein, Narcotics	858-5232
Dan Lemisch, Appeals	858-0686	Margaret Scott, Auto Theft	452-8688
Lisa Madzia, Domestic Violence	452-9177	John Skrzynski, Circuit Court	452-8699
Cheryl Matthews, Child Sexual Assault		John Slevin, District Court	858-5556
.....	858-0699	Gary Tunis, Economic Recovery	452-9865

Terri Antisdale	Scott Hamilton	John Pallas
Kathryn Barnes	Beth Hand	Craig Pavlock
Marc Barron	Shareen Hindo	Donna Pendergast
Mark Bilkovic	Marcel Hurt	Sheila Phillips
Denise Brainard	David Hutson	John Pietrofesa
Kimberly Brown	Hala Jarbou	Cynthia Pike
Jeff Buehner	Kate Jesudowich	Sara Pope-Starnes
Mark Cardellio	Charesa Johnson	Tricia Quigley
Deborah Carley	Julie Johnston	John Reiser, III
Michael Carpenter	Janice Kabodian	Thomas Richards
Elizabeth Chisholm	Todd Kaluzny	Susan Robison
Brett Chudler	Deanna Kelley	Matthew Roth
Edward Cibor	Debra King	Rae Ruddy
Charles Claus	Marsha Kosmatka	Shawn Ryan
Robert Cooper	Elizabeth Kulesz	Michael Salhaney
Jonathan Covault	Joseph Lavigne	Michael Sawicki
Diane D'Agostini	David Law	Sandra Scott
Justin Davis	Anica Letica	David Selwocki
Marilyn Day	Steven Lynch	Sydney Smith
Beth deBaptiste	Mary Mara	Charles Snell
Kenneth Frazee	Kristina Marticzak	Jennifer Stout
Jeanine Gibbs	Matthew Martin	John Taylor
Elizabeth Giddings	Thomas McAndrew	Joyce Todd
Robert Giles	Clara McCarthy	Gregory Townsend
Lorne Gold	Kate McNamara	Karen Urbin
Leonard Gorz	Rob Morad	Steven Vitale
Thomas Grden	Barbara Morrison	Paul Walton
Felicia Grimes	Karen Mysliwicz	Rose Warnicke
Ronda Gross	Robert Novy	Robert Williams
Jeffrey Hall	Shannon O'Brien	Robert Zivian

Public Administrators	Stephen C. Albery	Bloomfield Hills	858-2303
	Patricia F. Donaldson	Bloomfield Hills	645-2345
	Paul E. Dufault	Royal Oak	399-7272
	Irving B. Feldman	Southfield	352-1100
	Stanley G. Feldman	Southfield	357-3900
	Howard T. Linden	Southfield	358-4545
	Lynn Beatrice Rose	Birmingham	646-6442
	Roger E. Winkelman	Farmington Hills	489-8600

Risk Management and Safety (A)	Stanley B. Fayne, Risk Manager	858-5264
	Workers' Compensation	858-1588
	General Information	858-1014

Road Commission (C) (J)	645-2000
-------------------------------	----------

Rudy D. Lozano, Chairperson
 Larry P. Crake, Vice-Chairperson
 Richard G. Skarritt, Commissioner
 Brent O. Bair, Managing Director
 and Secretary/Clerk
 Gerald M. Holmberg, Deputy Managing Director
 and County Highway Engineer

(Road Commission continued on next page)

(Road Commission
continued)

Brian Blaesing, Director of Planning
and Development
Patrick Carty, Director of Legal
Craig B. Bryson, Public Information Officer
Deborah Mathews, Deputy Secretary/Clerk
Dennis A. Lockhart, Director of Finance
Doris Webster, Director of Personnel
Vacancy, Director of Engineering

- (C) David Allyn,
Director of Traffic-Safety 858-4802
- (C) James Dunleavy,
Director of Highway Maintenance 858-4881
- (C) William McEntee, Director of Permits
and Environmental Concerns 858-4835
- (C) Michael Richardson,
Director of Citizen Services 858-4804
- (C) Thomas Meszler,
Director of Central Operations 858-4798

Sanitary Code Appeal Board Nancy Dingeldey, Chairperson
Ruel E. McPherson, Vice-Chairperson
Edward P. O'Rourke
Theodore Spehar
Dr. Val C. Vangieson

Ronald L. Grimes, Administrator,
Environmental Health Services 858-1320

Schools, Superintendent of James Redmond, Ph.D. 209-2000
Rick Simonson, Deputy Superintendent
Brian Whiston, Legislative Affairs
Sherry L. McMillan, Director
of Human Resources
2100 Pontiac Lake Road, Waterford 48328-2735

*Sheriff (A) **Michael J. Bouchard** 858-5008
Thomas Quisenberry, Undersheriff 858-5002

Transportation Authority -
Public (A) **Members:** **Alternates:**
Michael Mayette, Chairperson Jeffrey J. Barthlow
C. Hugh Dohany E. Ann Hiner
Andrew Haliw III Dr. Dennis Papazian
James Merritt Michael Wooley
Charles Moss
Patricia Paruch

*Treasurer (A) Tax Information 858-0611
Deed/Plat Certification
Delinquent Tax Information
Tax Sale Information
Tax Statement Requests
Cash and Investments 858-0626
Administration
C. Hugh Dohany, Treasurer 858-0623
Patrick M. Dohany, Chief Deputy Treasurer 858-0624
Arthur Halsey, Chief-Treasurer Accounting 858-0621
James VanLeuven, Chief-Tax Administration 858-0611
Robert Dopke, Investment Administrator 858-5218

*Elected Officials

Veterans Services (A) (F) Diana Calvin, Manager 858-0785
 Belinda Shelton Duggan, Supervisor - Pontiac Office
 John (Jack) Becher, Supervisor
 Southeast Oakland Office 542-0220
 Garth Wootten, Supervisor,
 Walled Lake Office 926-3368
 Soldier's Relief Commission:
 Thelma Cannon
 Dennis L. Haiser
 Elmer Kretsch

Veterans, Michigan

Trust Fund Southeast Oakland Office
 P.O. Box 430070, Pontiac 48343-0070 542-0220

LOCATION OF COUNTY DEPARTMENTS

NOTE: FOR EFFICIENT MAIL DELIVERY,
 CONTACT EACH DEPARTMENT FOR INDIVIDUAL EXTENDED ZIP CODE.

- (A) County Service Center
 1200 N. Telegraph Road, Pontiac 48341
 County Service Center - Sheriff Department
 1201 N. Telegraph Road, Pontiac 48341-1044
- (B) 111 South Troy, Royal Oak 48067
- (C) 2420 Pontiac Lake Road, Waterford 48328
- (D) 2800 Watkins Lake Road, Waterford 48328
- (E) 27725 Greenfield Road, Southfield 48076-3625
- (F) 1010 E. West Maple, Walled Lake 48390-3588
- (G) One Public Works Drive, Waterford 48328 (main office)
- (H) 2401 East Fourth, Royal Oak 48067
- (I) 29142 Stephenson Highway, Madison Heights 48071 (branch)
- (J) 31001 Lahser Road, Beverly Hills 48025
- (K) 1700 Brown Road, Auburn Hills 48326
- (L) 250 Elizabeth Lake Road, Suite 1000W, Pontiac 48341
- (M) 230 Elizabeth Lake Road, Pontiac 48341
- (N) Central Administration -
 2100 N. Woodward, Suite 200, Bloomfield Hills 48304
 DISTRICT I - 1685 Baldwin Road, Pontiac 48340
 DISTRICT II - 31170 John R, Madison Heights 48071
 DISTRICT III - 195 Ladd Road, Walled Lake 48390
 DISTRICT IV - 235 N. Saginaw St., Pontiac 48342
 DISTRICT V - 2100 N. Woodward, Suite 200, Bloomfield Hills 48304

U.S. CONGRESSIONAL DISTRICTS

Balance in Livingston County (part)

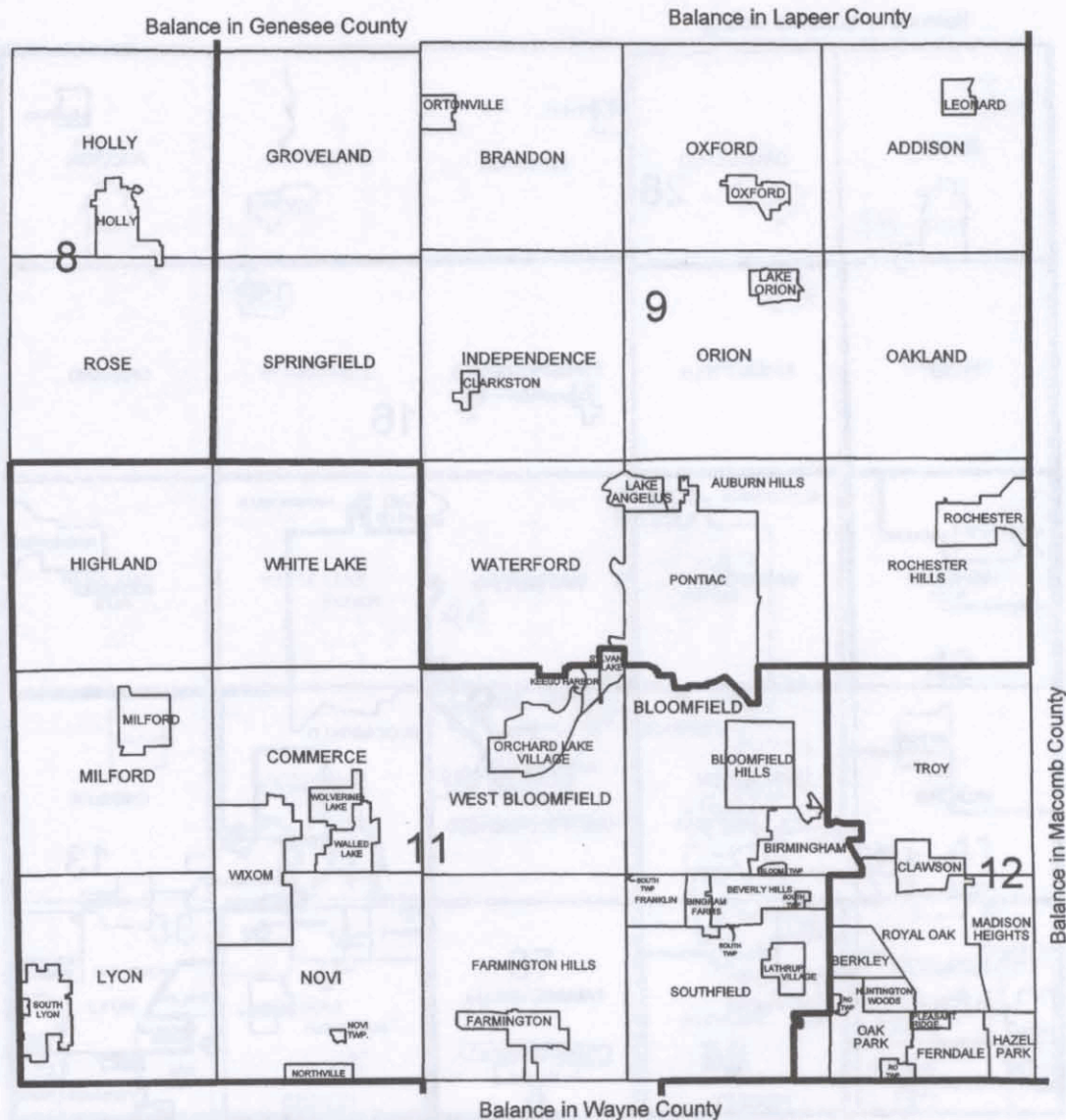

Balance in Macomb County

OAKLAND COUNTY, MICHIGAN
 PROVIDED BY OAKLAND COUNTY
 PLANNING AND ECONOMIC DEVELOPMENT SERVICES
 ©1995, Oakland County
 Created: January, 1997

STATE SENATE DISTRICTS

Balance in Genesee County

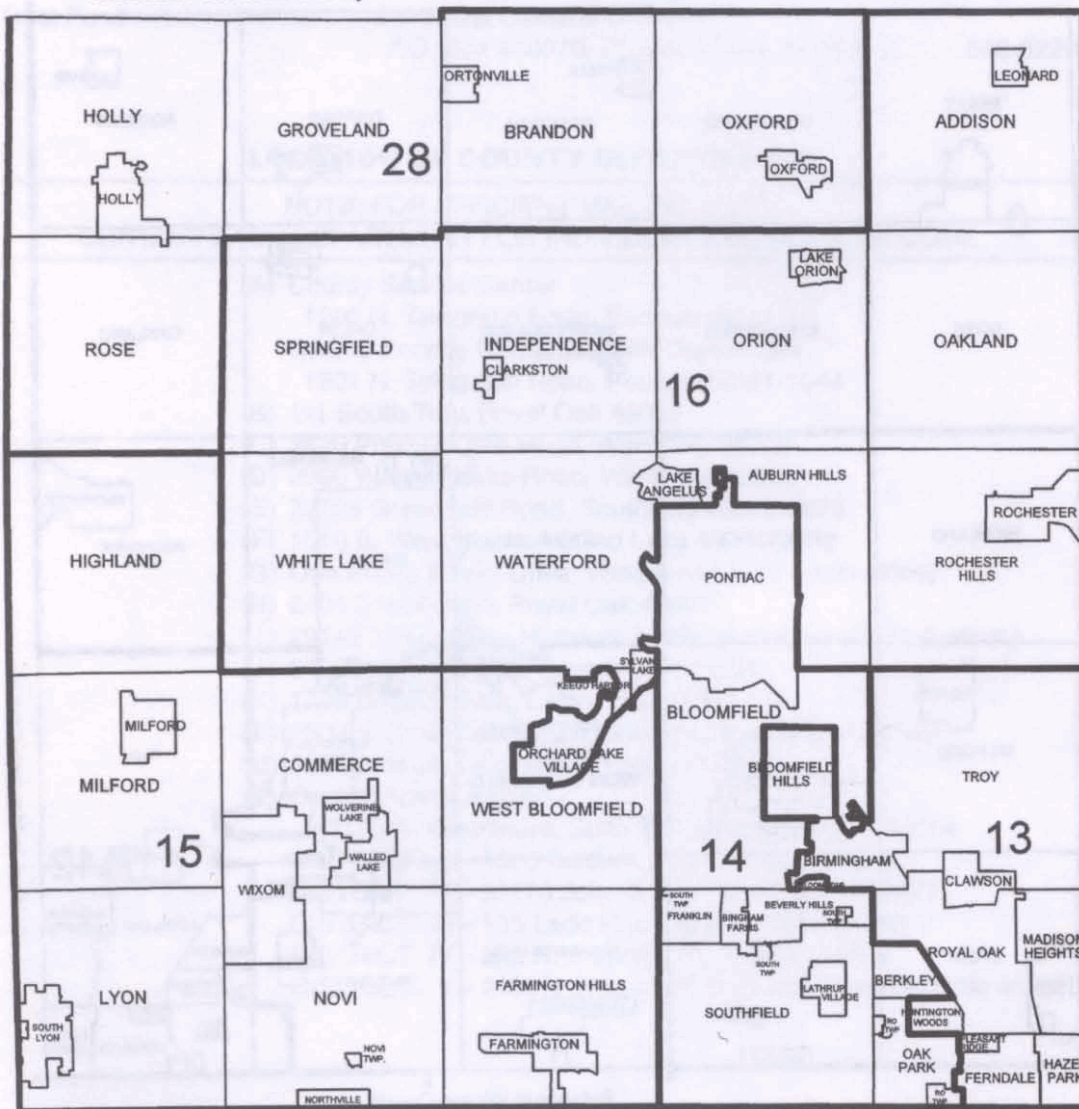

STATE REPRESENTATIVE DISTRICTS

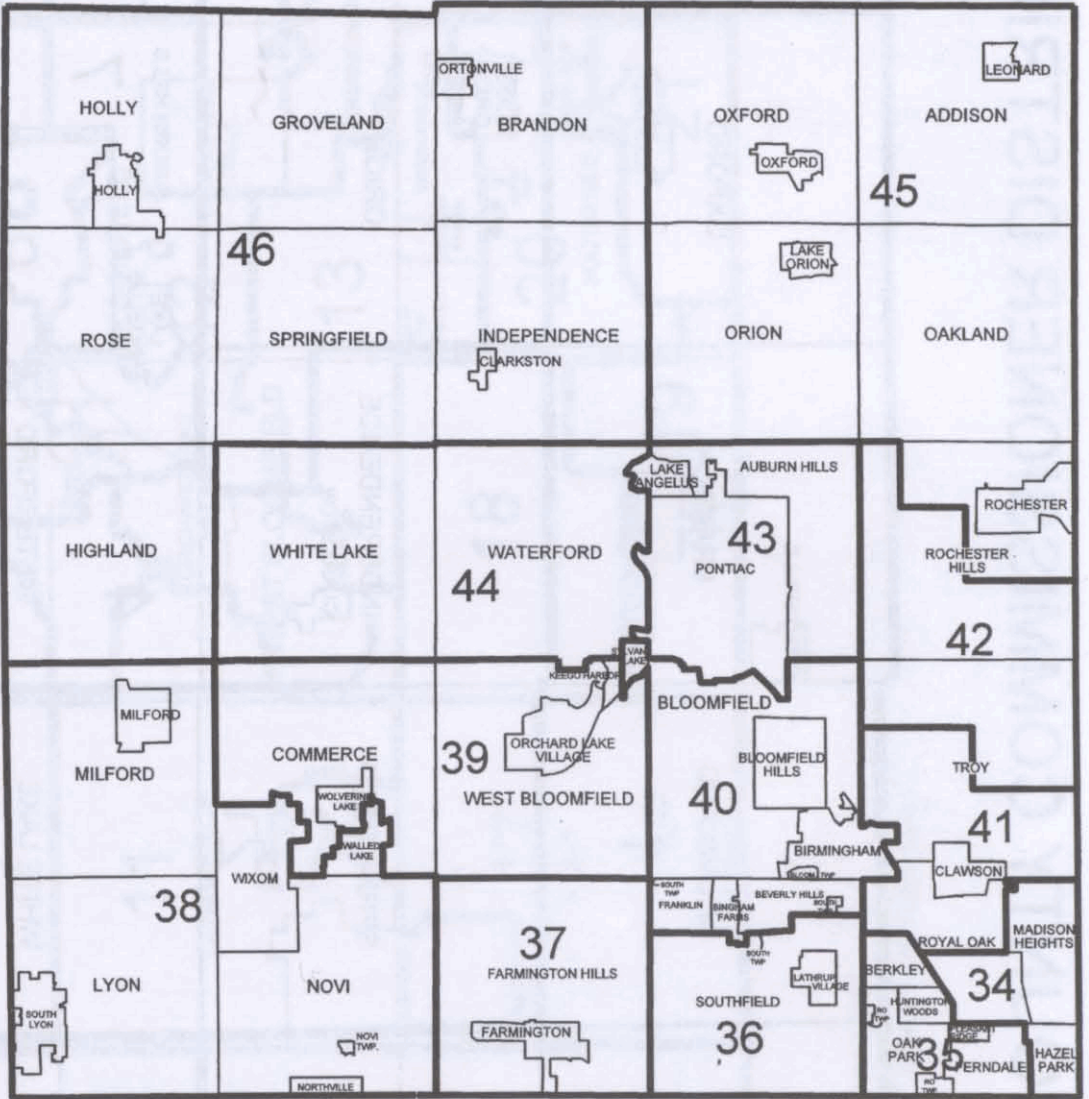

OAKLAND COUNTY, MICHIGAN
PROVIDED BY OAKLAND COUNTY
PLANNING AND ECONOMIC DEVELOPMENT SERVICES
©1995, Oakland County
Created: February 1996

COUNTY COMMISSIONER DISTRICTS

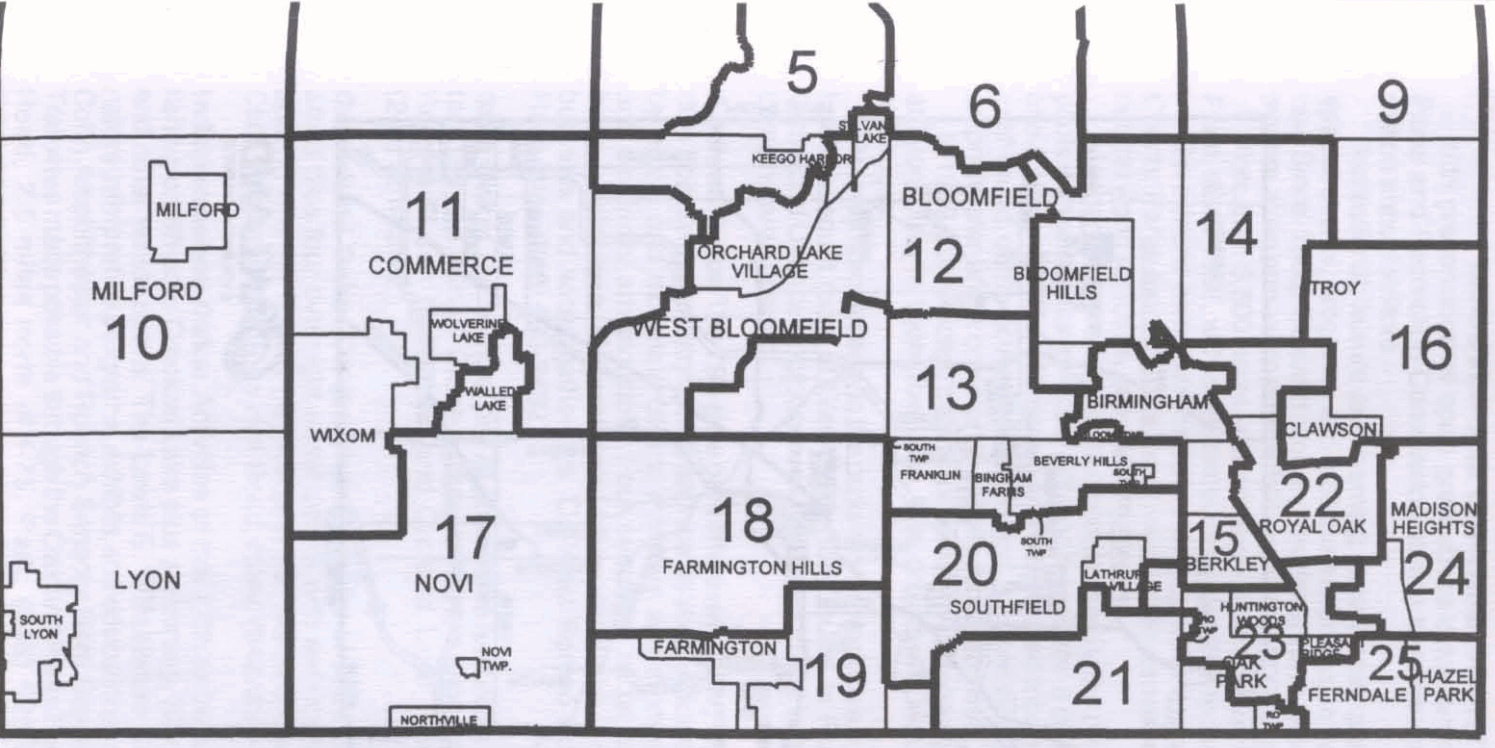
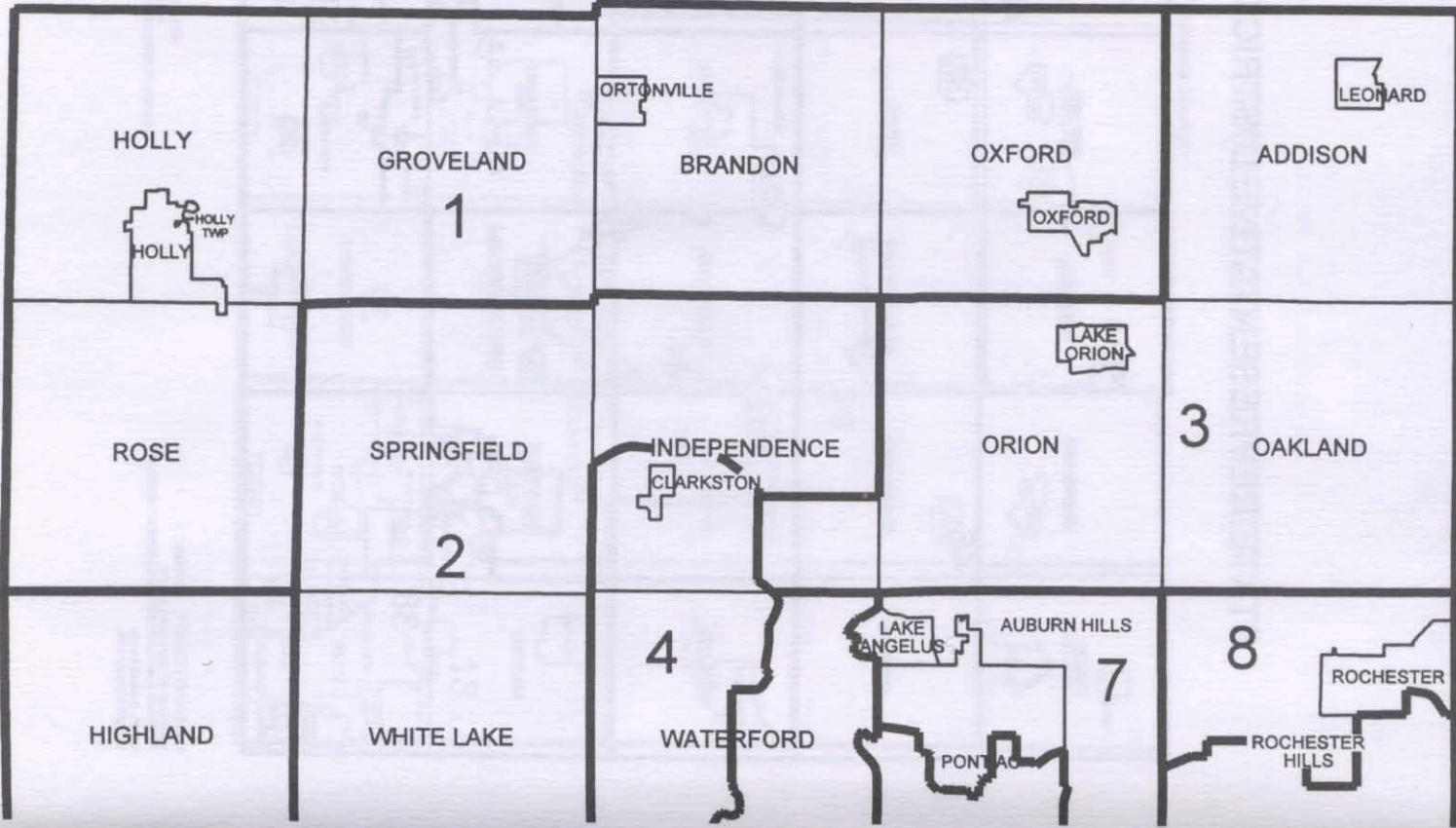

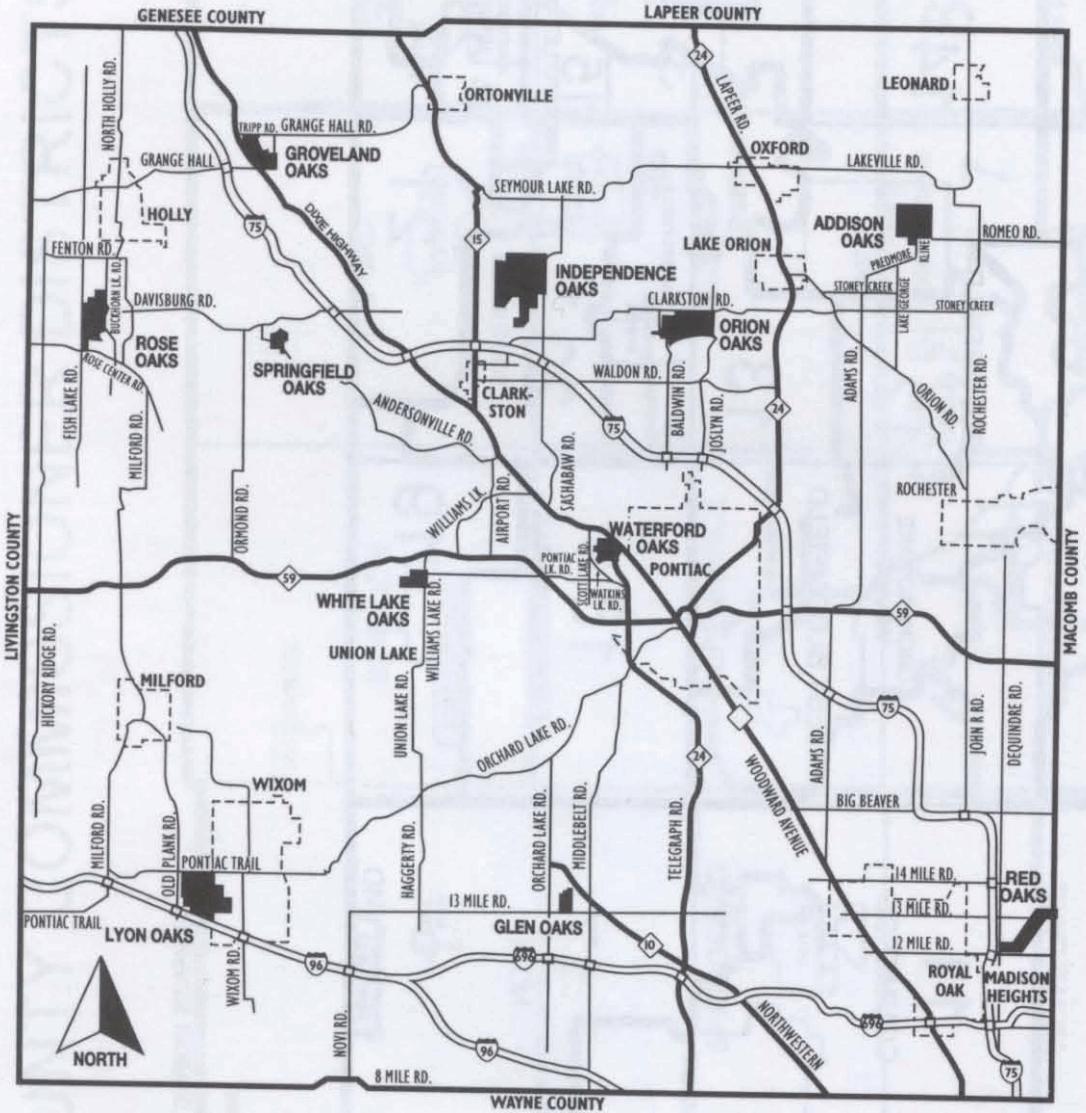

DISCOVER THE OAKLAND COUNTY PARKS

With preservation of open greenspace a top priority, the Oakland County Parks and Recreation Commission strives to enhance quality of life for its 1.5 million annual visitors.

Recreational, leisure and learning experiences are made possible through special events, programs and facilities supported, in part, by a one-quarter mill tax. Since 1966, Oakland County residents have voted to support the parks system at an annual cost of \$18.00 (per \$100,000 home).

More than 5,600 acres of land have been acquired by the Oakland County Parks since 1966, with assistance from state and federal grants.

Ten citizens comprise the policy-setting parks commission. The 11 Oakland County Parks function in an environmentally-sensitive manner to protect the natural world for future generations.

A leader in innovative facilities and programs, the parks offer two wave-action pools with waterslides — one waterpark features a children's water playground and a group raft ride; Michigan's first refrigerated toboggan run - "The Fridge"; a year-round, dome-covered driving range, a nature interpretive center, an outdoor amphitheater and a community mobile recreation fleet.

In 1999, construction begins for an Arthur Hills-designed, 18-hole golf course at Lyon Oaks in Lyon Township. The project will include a driving range and clubhouse.

Recent improvements in the parks system include a 3,000-square-foot addition to the banquet room at Glen Oaks Golf Course in Farmington Hills. Also, the Groveland Oaks campground was renovated to 462 larger sites and a new group camping area opened.

Addison Oaks: The 794-acre park offers swimming, fishing, boating, camping, disc golf, cross-country skiing and ice skating. Addison's trail system is used by hikers and mountain bikers. Primitive and modern campsites with water and electricity are available. Four overnight rental cabins feature two bunk beds, electricity, a refrigerator and table with chairs. A conference center hosts business and social gatherings. On West Romeo Road, nine miles north of Rochester. (248) 693-2432.

Glen Oaks: The 18-hole, par 70 golf course features a clubhouse with banquet facilities and lounge. Cross-country skiing is a winter option. On Thirteen Mile Road between Middlebelt and Orchard Lake Roads, Farmington Hills. (248) 851-8356.

Groveland Oaks: Campers have a choice of 462 campsites, group camping areas plus four overnight rental cabins with swimming, a waterslide, fishing, boating and the largest playscape in the Oakland County Parks system. Off Dixie Highway at Grange Hall Road, Holly. (248) 634-9811.

Independence Oaks: Activities at this 1,088-acre park include boating and fishing on 68-acre Crooked Lake plus swimming, hiking, cross-country skiing and other winter sports. The Lewis E. Wint Nature Center offers year-round nature interpretive programs, exhibits and educational outreach programs. The Cohn Amphitheater and Rubach Sensory Herb Garden and paved All Visitor Trail were made possible through the Oakland Parks Foundation. On Sashabaw Road, 2.5 miles north of I-75. Park: (248) 625-0877; Nature Center: (248) 625-6473.

Lyon Oaks: This 985-acre park, the first located in southwest Oakland County, will see construction of a golf course started in spring, 1999. The 18-hole Arthur Hills-designed course and driving range will open in 2001. A day-use area for hiking and picnicking will also be constructed. Bordered by Pontiac Trail, Old Plank Road and I-96 in Lyon Township. (248) 858-0906 for information.

Orion Oaks: Lake Sixteen can be used for boating or fishing from a wheelchair-accessible dock off Joslyn Road. Nearly 10 miles of mountain biking, hiking and cross-country ski trails are also available on Orion Oaks' scenic 927 acres. Bordered by Clarkston, Joslyn and Baldwin Roads in Orion Township. (248) 858-0906 for information.

Red Oaks: The Madison Heights **Waterpark** features a wave-action swimming pool, three-flume waterslide, deck and lawn area for sunbathing, picnic facilities, sun shelter, bath house and concessions. A 9-hole, par 31 **Golf Course** is on John R Road, between 12 and 13 Mile Roads. Cross-country skiing is a winter option. Across John R is a **Sports Village** with indoor and outdoor driving ranges, mini-car track, batting cages, 36 holes of adventure golf and children's playscape. Waterpark: (248) 585-6990; Golf Course: (248) 541-5030; Sports Village: (248) 548-1857.

Rose Oaks: Encompassing 613 acres, the system's 11th park was acquired in 1994. The site features three different ecosystems including 200 acres of wetlands, as well as frontage on two lakes. When developed, the park may be used for hiking, boating, fishing, swimming, picnicking and cross-country skiing. On Fish Lake Road, north of Rose Center Road, Rose Township. (248) 858-0906 for information.

Springfield Oaks: The Springfield Oaks complex includes an 18-hole championship **Golf Course** (par 71) and a multi-purpose **Activity Center** for banquets, receptions, shows and 4-H events plus two outdoor arenas. Cross-country skiing is a winter option at the golf course. On Andersonville Road in Davisburg. Golf Course: (248) 625-2540; Activity Center: (248) 625-8133.

Waterford Oaks: The 154-acre park is home to the commission's administrative offices. Waterford Oaks also offers a **Court Sport Complex** with eight tennis courts, two platform tennis courts, eight sand volleyball courts, shuffleboard, horseshoes courts, picnic shelters and children's play equipment. The park boasts **Michigan's first wave-action pool (The Wave) and double waterslide (Slidewinder) plus a group water raft ride (Ragin' Rapids) and children's water playground (The Big Bucket).** The park is also home to "The Fridge" - Michigan's first refrigerated toboggan run. The **Activity Center** is popular for weddings, recreation programs, banquets and parties. Classes, such as dog obedience, golf and aerobics, are also offered. In Waterford on Watkins Lake Road. Activity Center: (248) 858-0913; Waterpark: (248) 858-0918; Court Sport Complex: (248) 858-5433; BMX: (248) 858-0915; Refrigerated Toboggan Run: (248) 975-4440.

White Lake Oaks: At this 18-hole, par 70 course, facilities include a clubhouse with a pro shop and restaurant. A private room accommodates up to 250 persons for parties. Cross-country skiing is a winter option. On South Williams Lake Road off M-59, near Pontiac. (248) 698-2700.

OAKLAND COUNTY, MICHIGAN

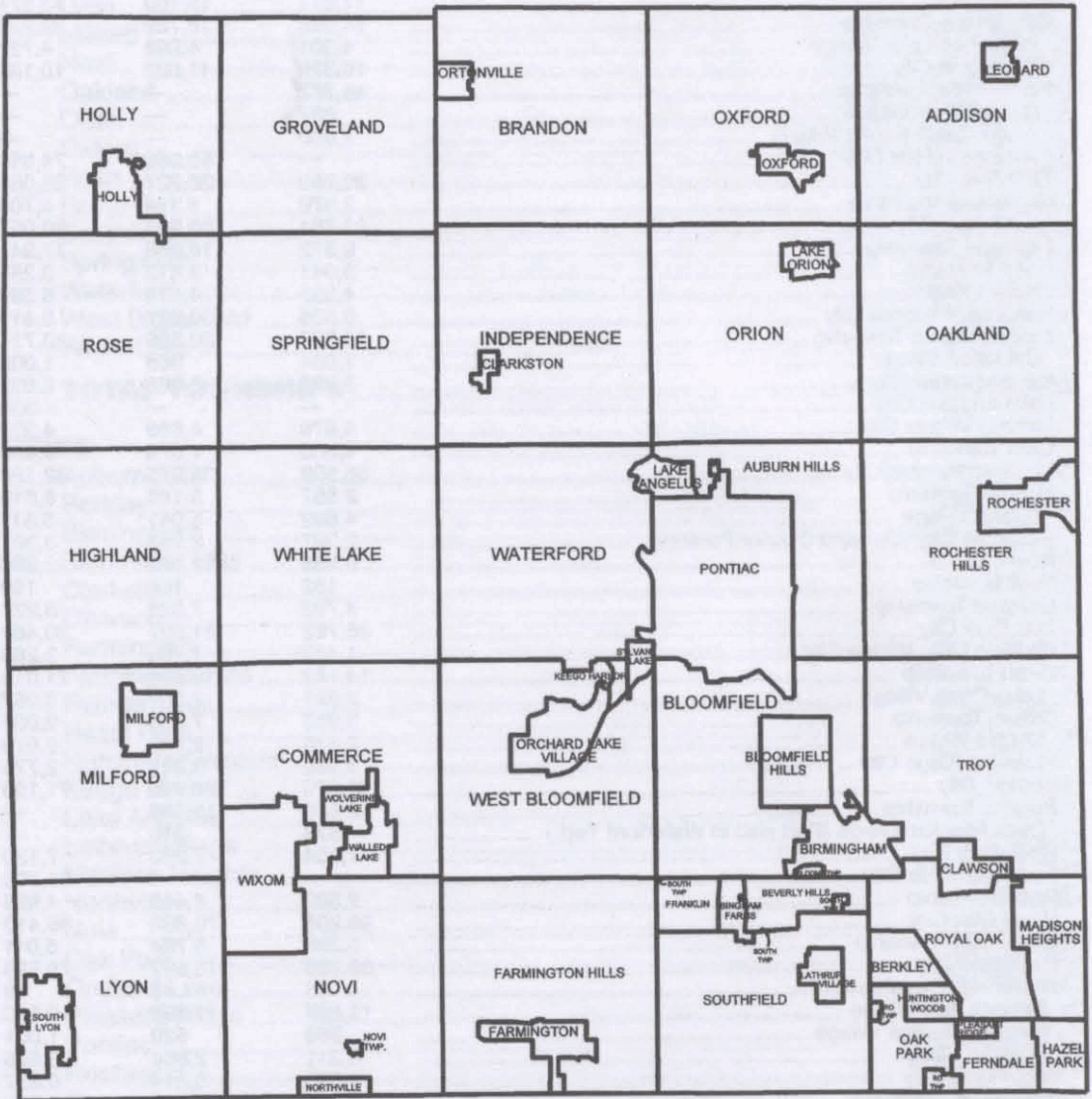

OAKLAND COUNTY, MICHIGAN
 PROVIDED BY OAKLAND COUNTY
 PLANNING AND ECONOMIC DEVELOPMENT SERVICES
 ©1995, Oakland County
 Revised: October, 1998

OAKLAND COUNTY CENSUS

	1970	1980	1990
Oakland County	907,871	1,011,793	1,083,592
Addison Township	2,431	4,184	4,785
** Leonard Village	378	423	357
Auburn Hills City	—	—	17,076
Avon Township	24,513	40,779	—
Berkley City	21,879	18,637	16,960
Birmingham City	26,170	21,689	19,997
Bloomfield Hills City	3,672	3,985	4,288
Bloomfield Township	42,788	42,876	42,473
Brandon Township	3,830	8,336	10,799
** Ortonville Village	983	1,190	1,252
Clawson City	17,617	15,103	13,874
Commerce Township	14,556	18,789	22,228
** Wolverine Lake Village	4,301	4,968	4,727
Farmington City	10,329	11,022	10,132
Farmington Township	46,767	—	—
Quakertown Village	837	—	—
Wood Creek Farms Village	1,090	—	—
Farmington Hills City	—	58,056	74,652
Ferndale City	30,850	26,227	25,084
Groveland Township	2,570	4,114	4,705
Hazel Park City	23,784	20,914	20,051
Highland Township	8,372	16,958	17,941
Holly Township	3,041	3,612	3,257
** Holly Village	4,355	4,874	5,595
Huntington Woods City	8,536	6,937	6,419
Independence Township	16,327	20,569	23,717
** Clarkston Village	1,034	968	1,005
Keego Harbor City	3,092	3,083	2,932
Lake Angelus City	—	—	328
Lathrup Village City	4,676	4,639	4,329
Lyon Township	4,500	7,078	9,450
Madison Heights City	38,599	35,375	32,196
Milford Township	2,557	5,146	6,610
** Milford Village	4,699	5,041	5,511
Northville City (Oakland County Portion)	2,367	2,785	3,367
Novi City	9,668	22,525	32,998
Novi Township	182	150	150
Oakland Township	4,793	7,628	8,227
Oak Park City	36,762	31,537	30,462
Orchard Lake Village City	1,487	1,798	2,286
Orion Township	14,189	19,566	21,019
** Lake Orion Village	2,921	2,907	3,057
Oxford Township	5,953	7,823	9,004
** Oxford Village	2,536	2,746	2,929
Pleasant Ridge City	3,989	3,217	2,775
Pontiac City	85,279	76,715	71,166
Pontiac Township	12,646	15,388	—
Lake Angelus Village (Part also in Waterford Twp.)	573	210	—
Rochester City	7,054	7,203	7,130
Rochester Hills City	—	—	61,766
Rose Township	2,502	4,465	4,926
Royal Oak City	86,238	70,893	65,410
Royal Oak Township	6,326	5,784	5,011
Southfield City	69,285	75,607	75,728
Southfield Township	46	40	18
** Beverly Hills Village	13,598	11,598	10,610
** Bingham Farms Village	566	529	1,001
** Franklin Village	3,311	2,864	2,626
South Lyon City	2,675	5,214	5,857
Springfield Township	4,388	8,295	9,927
Sylvan Lake City	2,219	1,949	1,884
Troy City	39,419	67,102	72,884
Walled Lake City	3,759	4,748	6,278
Waterford Township	59,123	64,250	66,692
Lake Angelus Village (Part also in Pontiac Twp.)	573	187	—
West Bloomfield Township	28,563	41,962	54,516
White Lake Township	14,311	21,870	22,608
Wixom City	2,010	6,705	8,550

** Townships that have a Village within their boundaries — add both Village and Township figure together for a true township census total.

1998 EQUALIZED VALUATION OF OAKLAND COUNTY

TOWNSHIPS

Addison	\$ 223,186,785
Bloomfield	2,756,543,150
Brandon	345,173,340
Commerce	1,304,580,600
Groveland	174,431,480
Highland	509,856,520
Holly	195,008,259
Independence	1,004,645,100
Lyon	343,821,450
Milford	578,265,770
Novi	7,011,040
Oakland	605,892,960
Orion	1,226,634,440
Oxford	408,177,208
Rose	172,118,950
Royal Oak	62,911,020
Southfield	814,239,920
Springfield	401,759,425
Waterford	1,929,151,400
West Bloomfield	2,796,478,966
White Lake	729,776,740

TOTAL TOWNSHIPS **\$16,589,664,523**

CITIES

Auburn Hills	\$ 1,120,731,860
Berkley	384,182,890
Birmingham	1,293,125,498
Bloomfield Hills	679,852,440
Clarkston	37,509,430
Clawson	312,031,750
Farmington	327,352,460
Farmington Hills	3,217,279,700
Ferndale	457,759,310
Hazel Park	245,123,140
Huntington Woods	248,804,540
Keego Harbor	68,982,190
Lake Angelus	48,034,620
Lathrup Village	144,939,490
Madison Heights	987,808,130
Northville	134,407,550
Novi	1,922,625,050
Oak Park	535,219,300
Orchard Lake	271,723,750
Pleasant Ridge	104,618,595
Pontiac	912,560,317
Rochester	363,246,890
Rochester Hills	2,542,175,950
Royal Oak	1,743,314,170
Southfield	3,059,113,304
South Lyon	196,234,783
Sylvan Lake	78,019,850
Troy	4,284,960,814
Walled Lake	165,646,370
Wixom	579,785,630

TOTAL CITIES **\$26,467,169,771**

TOTAL COUNTY **\$43,056,834,294**

**CUSTOMER SERVICE CENTER
PLANNING AND ECONOMIC DEVELOPMENT SERVICES**

**WHERE TO GET MAPS, AERIAL PHOTOGRAPHS
AND DEVELOPMENT INFORMATION**

If you are looking for property line maps, aerial photography, development data or business assistance, Oakland County Planning and Economic Development Services has what you need.

Property line maps of every parcel in Oakland County are updated each year. Aerial photography of the entire County is also available - our most current edition was taken in 1995. The aerials can be superimposed with the current property line maps or enlarged to a scale where detail as fine as telephone poles or parking lot lines are easily visible. Realtors and developers use aerials to locate available vacant land. If you ever need an aerial view of a street, home, place of business or accident site, Planning and Economic Development Services can provide you with a custom aerial enlargement.

The Oakland County Street Index Atlas is organized by geographic township and shows all streets, major roads, lakes, rivers, and municipal boundaries. A complete street index is included on each page. Special "theme" maps are also available which show such topics as zip codes, school districts, voting precincts, contaminated sites, planned road improvements, sewers, land use, and natural resources. These are just a few of the many maps available.

Development data and statistics are also available in a complete and user-friendly format. Population, housing, income, employment, land use, master plans, zoning and environmental data are collected and prepared. Staff is available to explain how the land is being used, where the wetlands and sensitive ecological areas are, soil conditions, population trends, ethnic makeup, median or per capita incomes and sewer locations.

School and civic group tours of the office are conducted upon request. We are also available to make presentations on various topics or projects.

So . . . if you need a map, aerial or some statistics, give us a call at Planning and Economic Development Services.

Oakland County Planning and Economic Development Services,
Executive Office Building, 1200 North Telegraph, Pontiac, MI 48341. Phone
(248) 858-0720 or (mapping) (248) 858-0723.

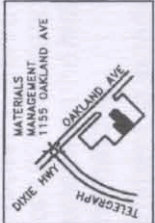
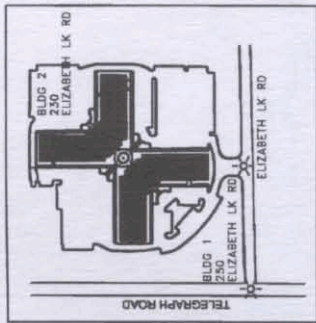

TO MATERIALS MANAGEMENT

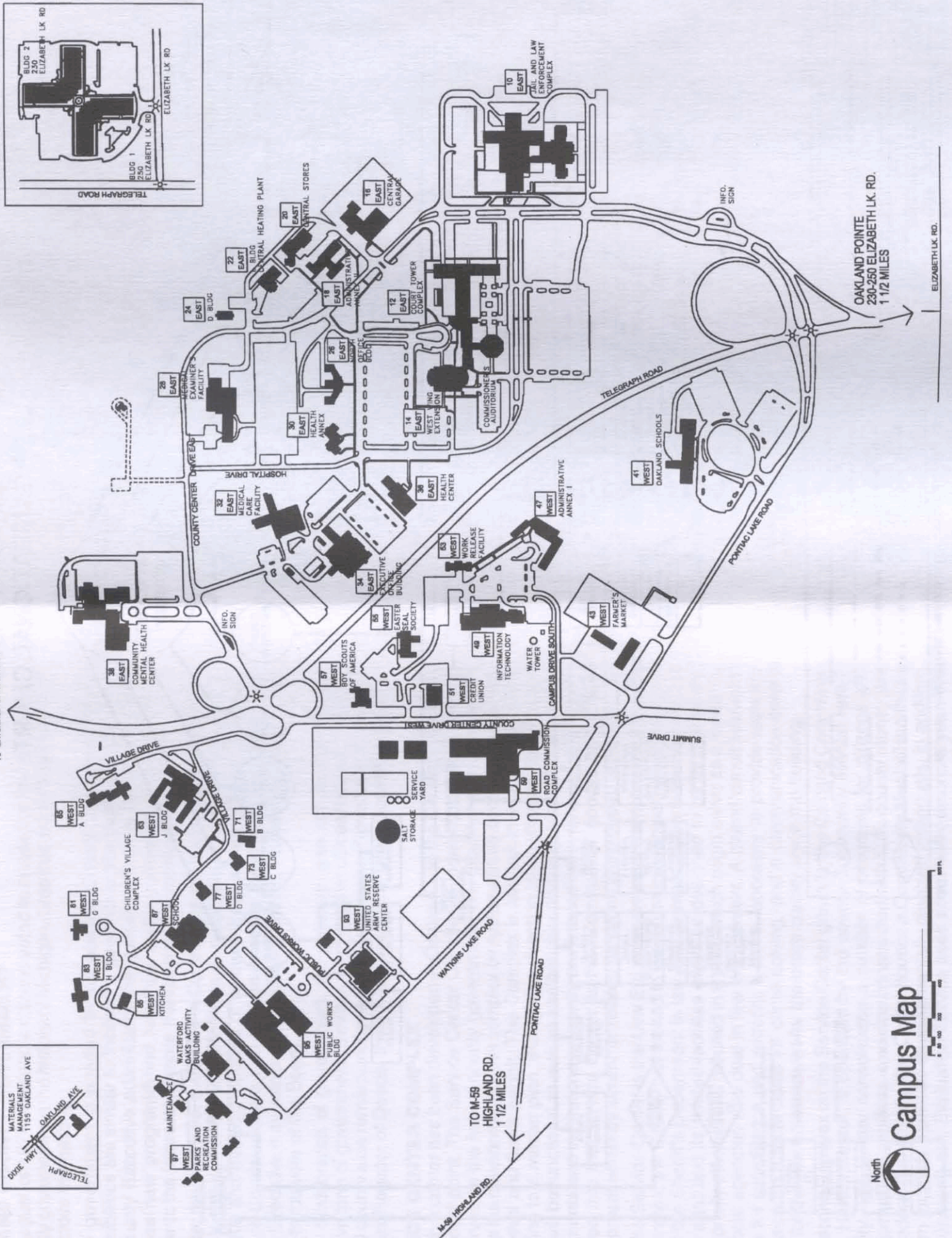

OAKLAND COUNTY GOVERNMENT ORGANIZATIONAL CHART

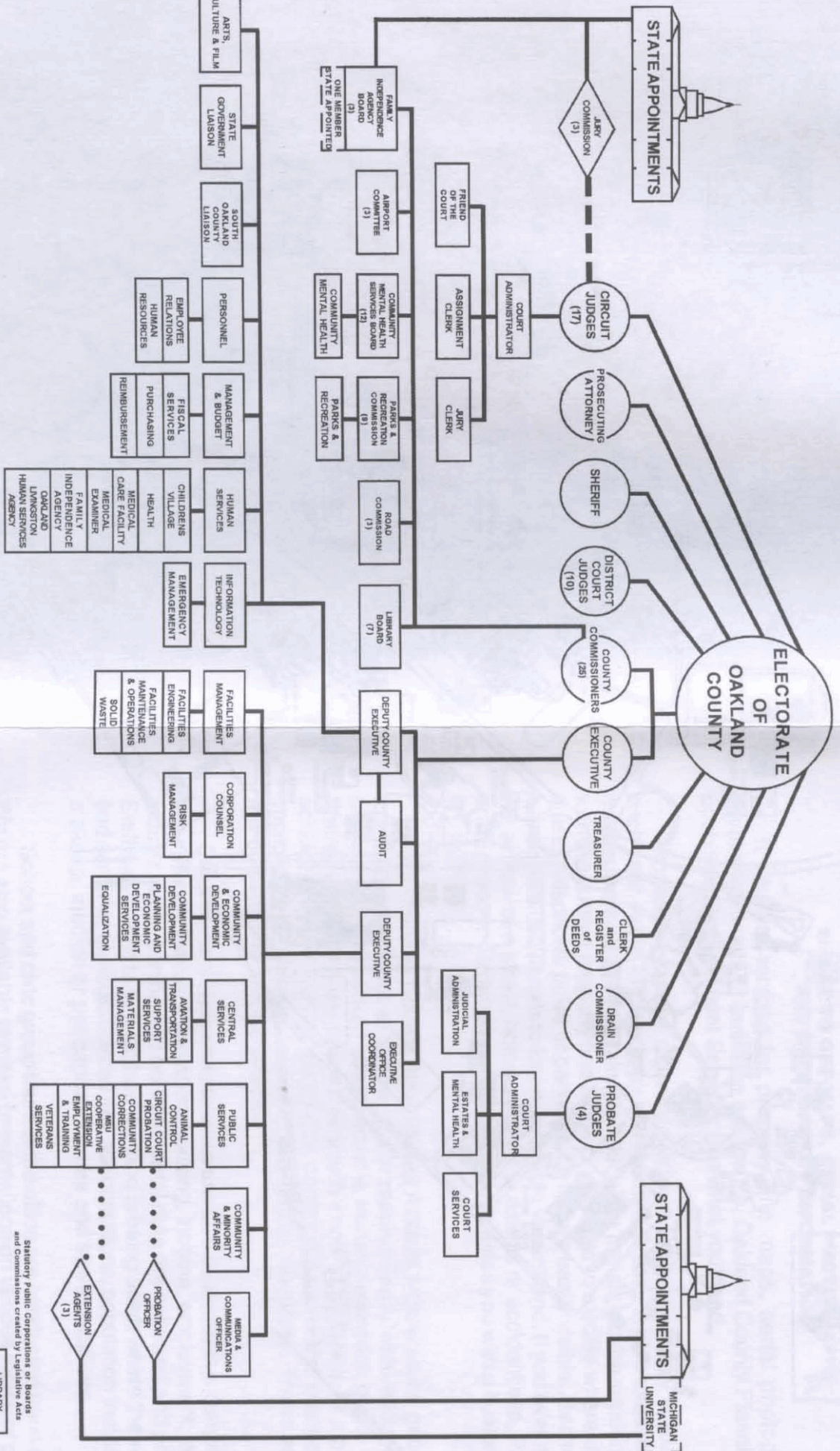

DRAIN BOARD (3)
Consists of Chairperson of the Board of Commissioners, Chairperson of the Drain Commission and the Drain Commissioner.

BOARD OF CANVASSERS (4)
Consists of four members appointed by the Board of Commissioners.

PLAY BOARD (3)
Consists of Chairperson of the Board of Commissioners who is Chairperson of the Play Board, the Clerk, Register of Deeds and the Treasurer.

EMPLOYEES RETIREMENT COMMISSION (9)
Consists of Chairperson of the Board of Commissioners, Chairperson of the Finance Committee, County Executive, three members selected by Oakland County retired employees and three employee members selected by the membership of the retirement system.

STATUTORY PUBLIC CORPORATIONS OR BOARDS AND COMMISSIONS CREATED BY LEGISLATIVE ACTS

- Act 138, P.A. 1917 as amended: LIBRARY BOARD (7)
- Act 116, P.A. 1954 as amended: ELECTION COMMISSION (3)
- Act 372, P.A. 1927 as amended: CONCEALED WEAPONS LICENSING BOARD (3)
- Act 311, P.A. 1948 (Ex. Session) as amended: BUILDING AUTHORITY (3)

OAKLAND COUNTY PLANNING AND ECONOMIC DEVELOPMENT SERVICES
JANUARY 1999

OAKLAND COUNTY GOVERNMENT

In August of 1974, Oakland's citizens voted to create the first unified form of county government in the history of Michigan. Less than 60 such governments exist across the nation.

The government is headed by an elected County Executive, whose responsibilities are similar to those of a governor or the mayor of a large city. The County Executive administers the government on a day to day basis, proposes new programs and revamps existing programs. The executive represents the interests of more than one million residents.

Under this structure, the Board of Commissioners performs a role similar to a state legislature or city council. It acts on proposals submitted by the County Executive and makes proposals of its own. Government policy is set by the Board of Commissioners and implemented by the County Executive. The County Executive may veto acts of the Board and the vetoes can be overridden by two-thirds vote of the Board.

The third branch of government, the judiciary, was not changed by the executive form of government. Similarly, the five other offices headed by officials elected countywide remain unchanged. These are the Prosecutor, the Sheriff, the Clerk/Register of Deeds, the Treasurer and the Drain Commissioner.

SERVICE CENTER COMPLEX

Such a center has been developed in Oakland and the Courthouse serves as its focal point. The Service Center Complex is located on a 450-acre site and serves as the hub of county government. The County has been working towards the development of this complex by systematically constructing facilities as needed and funds permit. The Complex is laid out in a spacious setting according to a master plan, thus giving direction to an ultimate development which will be functional as well as aesthetically pleasing. Most of the County's departments and institutions presently are housed here. One of the principles designed into the Service Center is the "Community" concept of campus development whereby similar or related functions are grouped together.

At the Service Center is the Law Enforcement - Jail Complex. In designing the Complex, the County has looked to the future in anticipating an expanded role for the Sheriff's Department in law enforcement. Nationwide research as to how a jail and its related facilities might be designed to be functional and operationally efficient has resulted in a plan, which might serve as a model for other local agencies who deal in law enforcement. A closed circuit television system for surveillance and security, a crime laboratory to provide technical assistance on a local basis for crime solving, and a communication control center for the law enforcement for the entire county are in the building.

A second Complex on the Service Center grounds, the Oakland Community Mental Health Center, is operated by the county Community Mental Health Authority. The Center consolidates a number of programs for citizens with developmental disabilities, and was constructed with 60% county money and 40% Federal grant funds. The Center houses a Community Mental Health day program for more than 130 developmentally disabled individuals; in addition, the Counseling and Evaluation Service sees about 425 persons a year. The building is unique in Michigan in having been funded well over half by county government; it also provides space for the administrative offices of Community Mental Health.

The Children's Village also is on the Service Center grounds. It provides shelter, care and treatment services for neglected and delinquent wards of the Court. Situated on fifty acres in the Service Center, it consists of small units which provide an opportunity to deal with individual problems of youth. The Village affords a home-like atmosphere to the troubled children coming to the attention of the Court. It is a model which evokes considerable favorable reaction from visitors and judges from throughout the State and other areas of the country.

Oakland's officials are proud of the County Courthouse Complex and its related facilities. Visitors from other counties, states and nations have found and will continue to find themselves most welcome.

OAKLAND COUNTY COMMUNITY MENTAL HEALTH AUTHORITY

Some people have serious, persistent psychiatric problems that can interfere with their whole life, especially on the job, in school, or in relationships with family and friends. Others are born with a developmental disability such as mental retardation, that will require special programming and services.

Oakland County's Community Mental Health Authority problems can help with these problems. Four major "case management" programs serve adults with serious mental illnesses in four quadrants of the County. Two Family Centers provide help for children with emotional impairments or who have developmental disabilities. Still other clinical programs provide for a variety of services to adults with developmental disabilities. These programs are staffed by psychiatrists, case managers, nurses, and other mental health professionals. Some programs are run with Authority employees, while others operate under contracts with Community Mental Health.

Fees are on a sliding scale, based on the individual's ability to pay, and Community Mental Health services are approved for reimbursement by Medicaid, Medicare, and various health insurances. These programs are part of a \$170 million system directed by the Oakland County Community Mental Health Authority Board of Directors, whose members are appointed by the County Board of Commissioners, and funding for the program comes primarily from the State of Michigan with County matching funds. The total system also includes 24-hour crisis services, inpatient psychiatric treatment, outpatient services, day programs for adults with mental illnesses and developmental disabilities, respite care for families, and a wide range of specialized services. The Oakland County CMH Authority is also the manager of all specialty mental health and developmental disability services to Medicaid eligible citizens and those insured under the State's MICHild health insurance program.

Most Community Mental Health programs are open Monday through Friday during day and some evening hours. At night and on weekends and holidays there is a Crisis Service operated by Common Ground in Pontiac; their help is available by phone or walk-in basis.

If you or someone you know — an adult or a child — may need professional mental health services, Community Mental Health is ready to help any way it can. These programs are supported by your tax dollars for the benefit of all eligible Oakland County residents.

For information or referral, just call "ACCESS", Community Mental Health's central intake unit, at (248) 858-1510. For crisis service day or night, call (248) 456-0909. Administrative offices are located in the Oakland County Service Center complex at 1200 N. Telegraph Road, Pontiac, MI 48341; phone (248) 858-1210.

OAKLAND COUNTY ROADS

More than half of all highways, roads, and streets in Oakland County are on the county system, which is under the jurisdiction of the Board of Oakland County Road Commissioners.

The Road Commission for Oakland County (RCOC) is now in its 86th year of service to the people of Oakland County.

Totaling over 2,500 miles, this system includes all public roads in townships, and through-streets in most cities and villages. It is the largest county system in Michigan and is second in size only to the state highway system. Its subdivision streets alone (all in townships) make up more than 900 miles.

About two-thirds of the system is paved. More than half is within the county's urban area, where some roads are four, five and six lanes wide to handle heavy traffic. A single intersection, in Southfield, is the meeting place for 100,000 vehicles daily. More than 1,200 electrical signals and over 90,000 signs are in use on the county road system.

The Road Commission does not levy a countywide tax, nor does anyone levy a tax countywide for roads.

The basic source of Road Commission revenue is the state-collected vehicle fuel and registration taxes, which motorists pay at the pump, and to the secretary of state. The state-collected taxes are the only source of substantial funding for county road maintenance, and snow and ice control.

Federal, county, municipal, township and property-owner contributions are also received, but generally only for specific road projects. Such projects include adding lanes, intersection improvements, paving gravel roads, adding new gravel, resurfacing paved roads, adding passing lanes, and other safety improvement projects.

In 1992, RCOC embarked on a program called FAST-TRAC, which is an Intelligent Transportation Systems (ITS) effort. The Road Commission has installed electronic "smart" traffic signals operated by computers and video vision at more than 350 intersections across the county. This system was the first adaptive traffic control in the United States, and the Road Commission was the first local unit of government to initiate a program of this scope and magnitude.

For paving and resurfacing of subdivision streets, property owners can petition RCOC to create a special assessment district through a process prescribed by state law. The process begins by contacting the Road Commission, then petitioning and participating in public hearings.

Members of the three-person Board of County Road Commissioners are appointed for staggered six-year terms by the elected Oakland County Board of Commissioners, which also sets their salaries. Salaries are funded by state-collected vehicle fuel and registration tax revenues. The Board of Road Commissioners is separate from county general government — establishing policies as authorized by state statutes for management of the countywide road system, administering its own budget, and hiring its own full-time managing director and staff.

Citizen requests for information are given special attention by the Road Commission's Department of Citizen Services (DCS). That office may be reached between 8:00 a.m. and 4:45 p.m. weekdays by dialing (248) 858-4804.

CITIES

CITY OF AUBURN HILLS 48326-2753

1827 North Squirrel Road

Phone (248) 370-9400 FAX (248) 370-9348

- COUNCIL James D. McDonald, Mayor
Henry V. Knight
Margaret A. Cooper
Michael Davis
Mari Harvey-Edwards
Tom McMillin
Kay Sendegas
- Clerk (Phone (248) 370-9404) Helen R. Venos
- Treasurer V. L. Valko
- Manager William R. Ross
- Chief of Police Doreen Olko
- Fire Chief Mark Walterhouse
- Assessor Victor Bennett
- Attorney William P. Hampton
- Building Department Manager David Thacker
- Civil Engineer Orchard, Hiltz and McCliment, Inc.
- Finance Director George Martini
- Public Services Director Glen Schoonfield
- District Court Judges (52nd-3rd) Ralph H. Nelson, Julie A. Nicholson and
James P. Sheehy....Rochester Hills

CITY OF BERKLEY 48072-1690

3338 Coolidge Highway

Phone (248) 546-2410 FAX (248) 546-2428

- COUNCIL John Mark Mooney, Mayor
Holly Martin
Anthony D. Agbay
Fred Collins
Ronald Meyer
David Mills
Eileen Steadman
- Clerk (Phone (248) 546-2420) Leona M. Garrett
- Treasurer Leona M. Garrett
- Manager William L. Rechlin
- Public Safety Director Bruce Henderlight
- Assessor Oakland County Equalization Division
- Attorney Charles M. Lowther
- Building Inspector City Municipal Services
- Finance Director Michael P. Tyler
- District Court Judge (45A) William R. Sauer

CITY OF BIRMINGHAM 48012-3001**151 Martin Street, P.O. Box 3001**

Phone (248) 644-1800 FAX (248) 644-5614

COMMISSIONERS	Scott D. Moore, Mayor Russell Dixon Archie Damman, III Robert A. DeLaura Dante J. Lanzetta, Jr. Chuck Moss Mike Wooley
Clerk	(Phone (248) 644-1800 Ext. 280) Judith A. Benn
Treasurer	Thelma Shivel
Manager	Thomas M. Markus
Chief of Police	Edward Ostin
Fire Chief	David Edginton
Assessor	Carol Hargan
Attorneys	Beier, Howlett, P.C.
Building Official	Mary Ferrario
Community Development Director	Patricia McCullough
Director of Engineering and Public Services	Dennis Dembiec
Finance Director	Sharon Nettie-Ostin
District Court Judges (48th)	Edward Avadenka, Gus Cifelli and Kimberly Small....Bloomfield Hills

CITY OF BLOOMFIELD HILLS 48304-2322**45 East Long Lake Road**

Phone (248) 644-1520 FAX (248) 644-4813

COMMISSIONERS	Benjamin T. Hoffiz, Mayor Marilynn I. Varbedian John Davey Dale Dawkins Michael T. Zambricki
Clerk	(Phone (248) 644-1520) Charles H. Harmon, Jr.
Treasurer	Joseph R. Secumski
City Manager	Charles H. Harmon, Jr.
Director of Public Safety	David R. Piche'
Assessor	Oakland County Equalization Division
Attorney	William P. Hampton
Building Inspector	John H. Hudock
Civil Engineer	Hubbell, Roth and Clark, Inc.
District Court Judges (48th)	Edward Avadenka, Gus Cifelli and Kimberly Small

CITY OF THE VILLAGE OF CLARKSTON 48346-1418
375 Depot Road

Phone (248) 625-1559 FAX (248) 625-3770

COUNCIL Sharron Catallo, Mayor
 Karen Sanderson
 Anne Clifton
 Daniel Colombo
 Walter Gamble, Jr.
 Michael Kelley
 David Savage

Clerk (Phone (248) 625-1559) Artemus M. Pappas
 Treasurer/Finance Director Artemus M. Pappas
 Manager Artemus M. Pappas
 Chief of Police Paul D. Ormiston
 Fire Chief Roland G. Wilson
 Assessor Oakland County Equalization Division
 Attorney Thomas J. Ryan
 Building Inspector Seymour Stone
 Civil Engineer Hubbell, Roth and Clark, Inc.
 District Court Judge (52nd-2nd) Gerald E. McNally

CITY OF CLAWSON 48017
425 North Main Street

Phone (248) 435-4500 FAX (248) 435-0515

COUNCIL Barbara L. Iseppi, Mayor
 Thomas A. Palmer
 Darrel Middlewood
 Michael Moulton
 William Schmidt

Clerk (Phone (248) 435-4500) Carol A. Kanirie
 Treasurer Kathryn M. Baker
 Manager Joseph Merucci
 Chief of Police Mike Walsh
 Fire Chief Kraig Bouse
 Assessor Oakland County Equalization Division
 Attorney Jon H. Kingsepp
 Building Inspector Louis Vitale
 Civil Engineer James R. Ball
 Finance Director John L. Modzinski
 District Court Judges (52nd-4th) William E. Bolle, Dennis C. Drury and
 Michael A. Martone....Troy

CITY OF FARMINGTON 48335**23600 Liberty Street**

Phone (248) 474-5500 FAX (248) 473-7261

COUNCIL	Mary L. Bush, Mayor William S. Hartsock Arnold T. Campbell JoAnne M. McShane James K. Mitchell	
Clerk	(Phone (248) 474-5500)	Patsy K. Cantrell
Treasurer/Finance Director		Patsy K. Cantrell
Manager		Frank J. Lauhoff
Director of Public Safety		Gary M. Goss
Assessor		John G. Sailer
Attorney		John M. Donohue
Building Inspector		John Koncsol
Civil Engineer		David Mariner
Director of Public Services		Kevin Gushman
District Court Judges (47th)	Frederick L. Harris and Marla E. Parker	

CITY OF FARMINGTON HILLS 48336-1165**31555 West Eleven Mile Road**

Phone (248) 474-6115 FAX (248) 474-5925

COUNCIL	Aldo Vagnozzi, Mayor Nancy Bates Vicki Barnett Jerry Ellis Jonathan L. Grant Cheryl Oliverio JoAnn Soronen	
Clerk	(Phone (248) 474-6115)	Kathryn A. Dornan
Treasurer/Finance Director		Charles D. Rosch
Manager		Steve Brock
Chief of Police		William J. Dwyer
Fire Chief		Richard Marinucci
Assessor		Dean Babb
Attorney		John M. Donohue
Building/Community Development Director		Dale Countegan
Building Inspector		Thomas Williams
City Engineer		William Otwell
Director of Public Services		Thomas P. Biasell
District Court Judges (47th)	Frederick L. Harris and Marla E. ParkerFarmington	

CITY OF FERNDALE 48220-1797**300 East Nine Mile Road**

Phone (248) 546-2360 FAX (248) 546-2369

COUNCIL	Charles G. Goedert, Mayor
	Gerry O. Kulick
	Robert J. Paczkowski
	Robert G. Porter
	Jonathan M. Warshay
Clerk	(Phone (248) 546-2384) Lee Ann O'Connor
Treasurer/Assessor	Dwayne G. McLachlan
City Manager	(Phone (248) 546-2360) Thomas Barwin
Chief of Police	Michael Kitchen
Fire Chief	William LeGault
Attorney	P. Daniel Christ
Building Inspector	Eugene Tutag
Community Development Services Director	George A. Peek
Constables	James R. Rentz and Wayne Edwin Smith
Engineering Technician	James Sobetski
Finance Director	Jaynmarie C. Hubanks
District Court Judge (43rd)	Joseph Longo

CITY OF HAZEL PARK 48030**111 East Nine Mile Road**

Phone (248) 546-4064 FAX (248) 414-5945

COUNCIL	Ben Colley, Mayor
	Donna Vance
	Jack F. Lloyd
	Kenneth J. Mayo
	Doug Pashakarnis
Clerk	(Phone (248) 546-4064) Mary Ellen Graver
Treasurer/Finance Director	Dee Ann Lewis
Manager	(Phone (248) 546-4060) K. Joseph Young
Chief of Police	Albert Sadow
Fire Chief	Raymond DeWalt
Assessor	Oakland County Equalization Division
Attorneys	Cooper, Shifman, Gabe, Quinn and Seymour
Community Development Director	Gary Carey
District Court Judge (43rd)	Keith P. Hunt

OAKLAND COUNTY RESEARCH LIBRARY
1200 N. TELEGRAPH ROAD DEPT 453
PONTIAC, MICHIGAN 48341-0453

CITY OF HUNTINGTON WOODS 48070-1199
26815 Scotia Road

Phone (248) 541-4300 FAX (248) 541-3412

COMMISSIONERS Ronald F. Gillham, Mayor
 Mary L. White
 Phyllis B.C. Kramer
 Robert F. Paul
 Leon W. Pratrnicki
 Clerk (Phone (248) 541-4300) Kathleen A. Keene
 Treasurer Kristine K. Hyre
 Manager Alex R. Allie
 Director of Public Safety Steven Fairman
 Fire Chief Douglas Conciatu
 Assessor Oakland County Equalization Division
 Attorneys Shifman and Carlson, P.C.
 Building Inspector Daniel Murray
 Civil Engineer Nowak and Fraus Corp.
 Finance Director Richard T. Lehmann
 District Court Judges (45B) Marvin F. Frankel and Benjamin J. Friedman
Oak Park

CITY OF KEEGO HARBOR 48320
2025 Beechmont, P.O. Box 665

Phone (248) 682-1930 FAX (248) 682-1635

COUNCIL Robert Burns, Mayor
 Arthur D. Nance
 Ralph W. Behler
 David A. Hofmann
 Barbara Kline
 Clerk (Phone (248) 682-1930) Christine Yates
 Treasurer/Finance Director Christine Yates
 Manager Michael J. Steklac
 Chief of Police Dennis Watkins
 Fire Chief William Brown
 Assessor Oakland County Equalization Division
 Attorney Thomas J. Ryan
 Building Official Rowe Engineering
 Civil Engineer Rowe Engineering
 District Court Judges (48th) Edward Avadenka, Gus Cifelli and
 Kimberly Small....Bloomfield Hills

CITY OF LAKE ANGELUS 48326**45 Gallogly Road**

Phone (248) 335-5396 FAX (248) 335-6570

COUNCIL Donald P. Althoff, Mayor
 George Frisch
 Rosalie Lake
 Lee McNew
 John Schimpke

Clerk (Phone (248) 335-5396) Nancy L. DeLorge
 Treasurer Nancy L. DeLorge
 Chief of Police Dan Black
 Assessor Jacqueline Dauw
 Attorney James L. Howlett
 Building Inspector Steven Thorpe
 District Court Judges (52nd-3rd) Ralph H. Nelson, Julie A. Nicholson and
 James P. Sheehy....Rochester Hills

CITY OF LATHRUP VILLAGE 48076-3489**27400 Southfield Road**

Phone (248) 557-2600 FAX (248) 557-2602

COUNCIL Frank M. Brock, Jr., Mayor
 Renee McClain
 Bruce Copus
 Karen Rousseaux
 Duane Welch

Clerk (Phone (248) 557-2600 Ext. 226) . Gloria Harris-Ford
 Treasurer Mark W. Pollock
 Administrator Jeffrey A. Bremer
 Chief of Police Robert Jones
 Fire Chief Robert Ozias
 Assessor Oakland County Equalization Division
 Attorneys Cooper, Shifman, Gabe, Quinn and Seymour
 Building Inspector Art Salatka
 Civil Engineer Giffels-Webster Engineers, Inc.
 Finance Director Jeffrey A. Bremer
 District Court Judges (46th) Stephen C. Cooper, Bryan H. Levy and
 Susan M. Moiseev....Southfield

CITY OF MADISON HEIGHTS 48071-1899
300 West Thirteen Mile Road

Phone (248) 588-1200 FAX (248) 588-8442

COUNCIL	Gary R. McGillivray, Mayor Richard L. Clark Ernest E. Fisher Douglas K. Mac Lean, Sr. Marilyn R. Russell Margene Ann Scott John Turchin
Clerk	(Phone (248) 583-0826) Geraldine A. Flack
Treasurer/Finance Director	Herbert V. Herriman
Manager	Jon R. Austin
Chief of Police	Michael Harries
Fire Chief	James Martin
Assessor	Terence M. Haran
Attorney	Larry Sherman
Building Inspection Administrator	William Miles
Community Development Director	James P. Schafer
District Court Judge (43rd)	Robert J. Turner

CITY OF NORTHVILLE 48167-1599
215 West Main Street

Phone (248) 349-1300 FAX (248) 349-9244

COUNCIL	Christopher J. Johnson, Mayor Carolann Ayers John G. Hardin Kevin Hartshorne Thomas F. Swigart
Clerk	(Phone (248) 349-1300) Dianne Massa
Treasurer	Geri Witkowski
Manager	Gary L. Word
Assistant City Manager/Finance Director	Nicolette Bateson
Chief of Police	James Petres
Fire Chief	James Allen
Assessor	Wayne County Appraisal Company
Attorney	James R. Kohl
Building Inspector	Rick Starling
Civil Engineer	McNeely and Lincoln
DPW Director	James Gallogly
District Court Judges (35th)	Ronald W. Lowe and John E. MacDonaldPlymouth

CITY OF NOVI 48375-3024**45175 West Ten Mile Road**

Phone (248) 347-0460 FAX (248) 347-0577

COUNCIL Kathleen S. McLallen, Mayor
 Hugh D. Crawford
 Craig DeRoche
 Edward G. Kramer
 Laura Lorenzo
 Kathleen M. Mutch
 Robert D. Schmid

Clerk (Phone (248) 347-0456) Tonni L. Bartholomew
 Treasurer Steven A. Babinchak
 Manager Edward F. Kriewall, Jr.
 Chief of Police Douglas F. Shaeffer
 Fire Chief Arthur R. Lenaghan
 Assessor Glenn Lemmon
 Attorney David M. Fried
 Building Official Donald Saven
 Civil Engineer JCK and Associates
 Director of Developmental Services Kerreen Conley
 Finance Director Leslie Gibson
 District Court Judges (52nd-1st) Michael Batchik, Brian W. MacKenzie and
 Dennis N. Powers

CITY OF OAK PARK 48237-2029**13600 Oak Park Boulevard**

Phone (248) 691-7400 FAX (248) 691-7167

COUNCIL Gerald E. Naftaly, Mayor
 Michael M. Seligson
 Raymond M. Abrams
 Arthur Frohlich
 Willie Horton

Clerk (Phone (248) 691-7544) Sandra K. Gadd
 Treasurer/Finance Director James Ghedotte
 Manager Daniel Fitzpatrick
 Director of Public Safety G. Robert Seifert
 Fire Chief John McNeilance
 Assessor Ronald Sztumerski
 Attorneys Shifman and Carlson
 Building Division Supervisor James Mores
 City Planner Kevin Rulkowski
 Civil Engineer Steve Chickonoski
 District Court Judges (45B) Marvin F. Frankel and Benjamin J. Friedman

CITY OF ORCHARD LAKE VILLAGE 48323-1605
3955 Orchard Lake Road

Phone (248) 682-2400 FAX (248) 682-1308

COUNCIL Gerald Kosmensky, Mayor
 Richard T. Hartzell
 Sylvia Beatty
 Shirley Itin
 Timothy C. McCabe
 Bruce H. McIntyre
 James K. Talpos

Clerk (Phone (248) 682-2400) Janet Overholt Green
 Treasurer Frank A. Copeland
 Chief of Police David J. King
 Fire Chief William Brown
 Assessor John G. Sailer
 Attorney L. Nicholas Treinen
 Building Inspector Rob Kehoe
 Civil Engineer Spalding, DeDecker Associates, Inc.
 District Court Judges (48th) Edward Avadenka, Gus Cifelli and
 Kimberly Small....Bloomfield Hills

CITY OF PLEASANT RIDGE 48069
23925 Woodward Avenue

Phone (248) 541-2900 FAX (248) 541-2504

COMMISSIONERS Ralph A. Castelli, Jr., Mayor
 Raymond F. Jahn, Jr.
 Cheryl A. Baker
 Mark W. LaChey
 Leonard W. Wessels

Clerk (Phone (248) 541-2900) Sherry W. Ball
 Treasurer Thomas E. Dempsey
 Interim Manager Sherry W. Ball
 Chief of Police Richard A. Vander Eyk
 Fire Chief William LeGault
 Assessor Oakland County Equalization Division
 Attorney Donald H. Gillis
 Building Inspector Daniel Murray
 Civil Engineer Anderson, Eckstein and Westrick, Inc.
 District Court Judges (45B) Marvin F. Frankel and Benjamin J. Friedman
Oak Park

CITY OF PONTIAC 48342-2271
450 Wide Track Drive, East

Phone (248) 857-7601 FAX (248) 857-8795

- COUNCIL Walter Moore, Mayor
 Ernest Allen, Sr., Deputy Mayor
 Clarence E. Phillips, President
 Gary A. Foster
 Ray Alexander
 John P. Bueno
 Charlie Harrison, III
 Everett L. Seay
 Susan Shoemaker
- Clerk (Phone (248) 857-7619) Mary H. Williams
- Treasurer Maurice (Butch) Finnegan
- Chief of Police Larry McNeary
- Fire Chief Jeffrey Hawkins
- Assessor Oakland County Equalization Division
- Attorney Cynthia Walker
- Building Inspector Thomas Farrell
- Civil Engineer Arthur Mitchell
- Community Development Director Steve Manning
- Finance Director Hymie Dahya
- District Court Judges (50th) Leo Bowman, Christopher C. Brown,
 Preston G. Thomas and William Waterman

CITY OF ROCHESTER 48307
400 Sixth Street, P.O. Box 10

Phone (248) 651-9061 FAX (248) 651-2624

- COUNCIL David Katulic, Mayor
 Thomas L. Werth
 David Becker
 Ann Marie Boyce
 Robert Head
 Karen Lewis
 Nicholas Storto
- Clerk (Phone (248) 651-9061) Nancy D. Hill
- Treasurer/Finance Director Thomas Skrobola
- Manager Kenneth A. Johnson
- Chief of Police Theodore Glynn
- Fire Chief Daniel Jacobson
- Assessor Oakland County Equalization Division
- Attorney Sara Cox
- Building Inspector Edward Alward
- Civil Engineer Hubbell, Roth and Clark, Inc.
- District Court Judges (52nd-3rd) Ralph H. Nelson, Julie A. Nicholson and
 James P. Sheehy....Rochester Hills

CITY OF ROCHESTER HILLS 48309-3033
1000 Rochester Hills Drive

Phone (248) 656-4600 FAX (248) 656-4744

COUNCIL	Kenneth D. Snell, Mayor John D. Gaber, President Gerald J. Robbins John L. Dalton Susan deCausin Lois Golden Melinda Hill Patricia Somerville
Clerk	(Phone (248) 656-4630) Beverly A. Jasinski
Treasurer	Robert Spaman
Assistant to Mayor	Marc Ott
Chief of Police	Oakland County Sheriff Department
Fire Chief	William Thornton
Assessor	Kurt Dawson
Attorney	Lawrence R. Ternan
Building Director	William Dinnan
Director of Public Services	Thomas Dohr
Parks, Forestry & Facilities Director	Michael A. Hartner
Planning/Zoning Director	Patricia Goodwin
District Court Judges (52nd-3rd)	Ralph H. Nelson, Julie A. Nicholson and James P. Sheehy

CITY OF ROYAL OAK 48068-0064
211 Williams Street, P.O. Box 64

Phone (248) 546-1000 FAX (248) 546-1546

COMMISSIONERS	Dennis G. Cowan, Mayor Michael Andrzejak Marie L. Donigan Laura J. Harrison Thomas E. Kuhn Ilene M. Lanfear Peter H. Webster
Clerk	(Phone (248) 544-6655) Mary C. Haverty
Treasurer	Michael Kondek
Manager	Lawrence M. Doyle
Chief of Police	Mel Johnson
Fire Chief	Donald Stanford
Assessor	Richard Vincent
Attorney	Charles Semchena
Building Inspector	Kelly Winters
City Engineer	Richard Cole
Finance Director	Richard Eva
District Court Judges (44th)	Terrence H. Brennan and Daniel Sawicki

CITY OF SOUTHFIELD 48076**26000 Evergreen Road**

Phone (248) 354-1000 FAX (248) 354-7937

COUNCIL	Donald F. Fracassi, Mayor Brenda Lawrence, President Nida Samona Paul Condino Myron A. Frasier Sylvia Jordan Sidney Lantz Joan Seymour
Clerk	(Phone (248) 354-9380) Mary A. Bonner
Treasurer	Roman J. Gronkowski
Acting Administrator	Donald J. Gross
Chief of Police	Joseph E. Thomas
Fire Chief	Robert Ozias
Assessor	Barry Simon
Attorney	John E. Beras
Building Official	Wayne Jewell
Engineer	Wayne Bonus
Finance Director	James Scharret
District Court Judges (46th)	Stephen C. Cooper, Bryan H. Levy and Susan M. Moiseev

CITY OF SOUTH LYON 48178**335 South Warren**

Phone (248) 437-1735 FAX (248) 486-0049

COUNCIL	Jeffrey L. Potter, Mayor Glenn Kivell Mark Dones John Doyle, Jr. John Galeas, Jr.
Clerk	(Phone (248) 437-1735) Julie C. Zemke
Treasurer	Julie C. Zemke
Manager	Rodney L. Cook
Chief of Police	Lloyd T. Collins
Fire Chief	Craig Kaska
Assessor	Josephine Lentine
Attorneys	Booth Patterson, P.C.
Building Inspector	Joseph P. Veltri
District Court Judges (52nd-1st)	Michael Batchik, Brian W. MacKenzie and Dennis N. Powers....Novi

CITY OF SYLVAN LAKE 48320-1679**1820 Inverness Street**

Phone (248) 682-1440 FAX (248) 682-7721

COUNCIL	Stuart Bandalene, Mayor William Piontkowski Shalina Kumar Pete Peters Walter Roesler
Clerk	(Phone (248) 682-1440) Dennise Clippert
Treasurer	Dennise Clippert
Manager	John Martin
Chief of Police	Marvin D. McTavish
Fire Chief	William Brown
Assessor	Oakland County Equalization Division
Attorney	Paul Bibeau
Building Inspectors	Gerry McCallum and Tom Richey
Finance Director	John Martin
District Court Judges (48th)	Edward Avadenka, Gus Cifelli and Kimberly Small....Bloomfield Hills

CITY OF TROY 48084-5285**500 West Big Beaver Road**Phone (248) 524-3300 FAX (248) 524-0851 WEB: www.ci.troy.mi.us

COUNCIL	Jeanne M. Stine, Mayor Henry W. Allemon Anthony N. Pallotta Matt Pryor Louise E. Schilling John R. Stevens Eldon J. Thompson
Clerk	(Phone (248) 524-3316) Tamara A. Renshaw
Treasurer	Nancy Aguinaga
Manager	James C. Bacon, Jr.
Chief of Police	Charles Craft
Fire Chief	William Nelson
Assessor	Nino Licari
Attorney	John J. Martin, III
Director of Building and Zoning	Gary A. Shripka
City Engineer	C. Neall Schroeder
Finance Director	John M. Lamerato
District Court Judges (52nd-4th)	William E. Bolle, Dennis C. Drury and Michael A. Martone

CITY OF WALLED LAKE 48390-9007
1499 E. West Maple Road, P.O. Box 9007

Phone (248) 624-4847 FAX (248) 624-1616

COUNCIL	William T. Roberts, Mayor James D. Clifton Linda S. Ackley William I. Burke Diane Cartter Helen Foss Heather F. M. Hill	
Clerk	(Phone (248) 624-4847)	Maryanne Cornelius
Treasurer/Finance Director		Joyce M. Golden
Manager		Phillip S. Vawter
Chief of Police		Jerry L. Walker
Fire Chief		William A. Conn
Assessor		Oakland County Equalization Division
Attorneys	Secrest, Wardle, Lynch, Hampton, Truex and Morley	
Building Inspector		Edwin Jonas
Civil Engineer		McNamee, Porter and Seeley
Director of Public Works		Loyd Cureton
Director of Planning and Development		Miles A. Davis
District Court Judges (52nd-1st)	Michael Batchik, Brian W. MacKenzie and Dennis N. Powers....Novi	

CITY OF WIXOM 48393-2567
49045 Pontiac Trail

Phone (248) 624-4557 FAX (248) 624-0863

COUNCIL	Michael McDonald, Mayor John V. Momberg Mark Clancey Richard Johnson John Lee Suzanne McFadden Vernon Mitchell	
Clerk	(Phone (248) 624-4557)	June Buck
Treasurer/Finance Director		Kevin Brady
Manager		J. Michael Dornan
Assistant Manager		Frank Sheridan
Chief of Police		Tony Dattilo
Fire Chief		George Spencer
Assessor		John G. Sailer
Attorneys	Connelly, Crowley, Groth and Seglund	
Building Official		John Lipchik
Civil Engineer		Hubbell, Roth and Clark, Inc.
Community Services Director		Deanna Magee
Department of Public Services Director		Gregory S. McCaffery
Department of Public Works Administrator		William (Ben) McCusker
District Court Judges (52nd-1st)	Michael Batchik, Brian W. MacKenzie and Dennis N. Powers....Novi	

TOWNSHIPS

TOWNSHIP OF ADDISON

1440 Rochester Road, Leonard 48367

Phone (248) 628-3317 FAX (248) 628-2207

Supervisor	A. Robert Koski
Clerk	(Phone (248) 628-3317) Pauline Bennett
Treasurer	Ray E. Terry
Trustees	Ed Brakefield
.....	Patricia Eisenhardt
.....	Michael McDonald
.....	Sandra Rowland-Campbell
Chief of Police	Oakland County Sheriff Department
Fire Chief	George Spencer
Assessor	Heidi Roenicke
Attorney	L. Nicholas Treinen
Building Inspector	John Elsarelli
Civil Engineer	JCK and Associates, Inc.
District Court Judges (52nd-3rd)	Ralph H. Nelson, Julie A. Nicholson and James P. Sheehy....Rochester Hills

CHARTER TOWNSHIP OF BLOOMFIELD

4200 Telegraph Road, P.O. Box 489, Bloomfield Hills 48303-0489

Phone (248) 433-7700 FAX (248) 433-7714

Supervisor	Fred Korzon
Clerk	(Phone (248) 433-7702) Wilma S. Cotton
Treasurer	David Payne
Trustees	Janet Roncelli
.....	Sherry Stefanos
.....	Jerry J. Tobias
.....	William R. Yaw, Jr.
Chief of Police	Jeffrey Werner
Fire Chief	Leo Chartier
Assessor	Richard B. Farms
Attorney	William Hampton
Building Inspector/Civil Engineer	Wayne Domine
District Court Judges (48th)	Edward Avadenka, Gus Cifelli and Kimberly Small....Bloomfield Hills

CHARTER TOWNSHIP OF BRANDON
395 Mill Street, P.O. Box 429, Ortonville 48462

Phone (248) 627-2851 FAX (248) 627-3719

Supervisor Pat Alexander
 Clerk (Phone (248) 627-2851) Sally Jo Swayne
 Treasurer (Phone (248) 627-2853) Linda Owen
 Trustees Ronald Lapp
 Thomas Stowell
 James Webb
 Sandra Willett
 Constables James Frantz and Edward LaDouceur
 Chief of Police Oakland County Sheriff Department
 Fire Chief Robert McArthur
 Assessor Landmark Appraisal Company
 Attorneys Richard Campbell and Stuart Cooney
 Building Inspector Timothy Palulian
 Civil Engineer Hubbell, Roth and Clark, Inc.
 District Court Judge (52nd-2nd) Gerald E. McNally
Clarkston

CHARTER TOWNSHIP OF COMMERCE
2840 Fisher Avenue, Commerce Township 48390

Phone (248) 624-0110 FAX (248) 624-5384

Supervisor Thomas K. Zoner
 Clerk (Phone (248) 960-7020) Sandra S. Abrams
 Treasurer Susan L. Gross
 Trustees Robert J. Long
 Cheryl Magalski
 Daniel P. Munro
 Rick Sovel
 Chief of Police Oakland County Sheriff Department
 Fire Chief Ronald Bolitho
 Assessor E. Wynn Berry
 Attorney Phillip G. Adkison, P.L.L.C.
 Building/Zoning Administrator Kenneth D. Campbell
 Civil Engineer Giffels-Webster Engineers, Inc.
 District Court Judges (52nd-1st) Michael Batchik, Brian W. MacKenzie and
 Dennis N. Powers....Novi

TOWNSHIP OF GROVELAND
4695 Grange Hall Road, Holly 48442

Phone (248) 634-4152 or (248) 627-3585 FAX (248) 634-1351

Supervisor Robert DePalma
 Clerk (Phone (248) 634-4152) Beth J. Steele
 Treasurer Shirley A. Scramlin
 Trustees David C. Ax
 Diane Howell
 Chief of Police Michigan State Police
 Fire Chief Merilyn McGee
 Assessor Oakland County Equalization Division
 Attorney Thomas G. Plunkett
 Building Inspector Steven R. McGee
 Civil Engineers Wehner Engineering
 Orchard, Hiltz and McCliment, Inc.
 District Court Judge (52nd-2nd) Gerald E. McNally
Clarkston

CHARTER TOWNSHIP OF HIGHLAND
205 North John Street, P.O. Box 249, Highland 48357-0249

Phone (248) 887-3791 FAX (248) 887-1937

Supervisor John P. Stakoe
 Clerk (Phone (248) 887-3791 Ext. 5) William E. Brian
 Treasurer Patricia L. Woods
 Trustees Judy Dietrich
 Richard Gruber
 Kenneth G. Hurst
 Nancy E. Sharp
 Chief of Police Oakland County Sheriff Department
 Fire Chief James Crunk
 Assessor Nancy Jones
 Attorneys Connelly, Crowley, Groth and Seglund
 Building Inspector Joseph F. Weinburger
 Civil Engineer Powell and Associates Engineers, Inc.
 District Court Judges (52nd-1st) Michael Batchik, Brian W. MacKenzie and
 Dennis N. Powers....Novi

TOWNSHIP OF HOLLY

102 Civic Drive, Holly 48442-1505

Phone (248) 634-9331 FAX (248) 634-5482

Supervisor Dale M. Smith
 Clerk (Phone (248) 634-9331) Cindy M. Hall
 Treasurer Bernice M. Alexander
 Trustees Ronald W. Applegate
 Gary M. Collins
 Chief of Police Michigan State Police
 Fire Chief Roger W. Caster
 Assessor Gregory MacAlpine
 Attorneys Booth Patterson, P.C.
 Building Inspector Chris Davis
 Civil Engineer Hubbell, Roth and Clark, Inc.
 District Court Judge (52nd-2nd) Gerald E. McNally
Clarkston

CHARTER TOWNSHIP OF INDEPENDENCE

90 North Main Street, P.O. Box 69, Clarkston 48347

Phone (248) 625-5111 FAX (248) 625-2585

Supervisor Dale A. Stuart
 Clerk (Phone (248) 625-5111 Ext. 203) ... Joan E. McCrary
 Treasurer James R. Wenger
 Trustees Jeffrey M. McGee
 Larry Rosso
 Daniel F. Travis
 Neil E. Wallace
 Chief of Police Oakland County Sheriff Department
 Fire Chief Gar Wilson
 Assessor David Kramer
 Attorneys Secrest, Wardle, Lynch, Hampton, Truex and Morley
 Building Director Beverly McElmeel
 Civil Engineer Hubbell, Roth and Clark, Inc.
 District Court Judge (52nd-2nd) Gerald E. McNally
Clarkston

CHARTER TOWNSHIP OF LYON
58000 Grand River Avenue, New Hudson 48165

Phone (248) 437-2240 FAX (248) 437-2336

Supervisor James F. Atchison
 Clerk (Phone (248) 437-2240 Ext. 14) Pamela Johnson
 Treasurer Patricia D. Carcone
 Trustees Daniel L. Cash
 Paul Fransway
 Timothy R. Reed
 Joseph E. Shigley, Jr.
 Chief of Police Oakland County Sheriff Department
 Fire Chief Leslie L. Cash
 Assessor Oakland County Equalization Division
 Attorney Matthew Quinn
 Building Inspector Lorrain Phillips
 Civil Engineer Orchard, Hiltz and McCliment, Inc.
 District Court Judges (52nd-1st) Michael Batchik, Brian W. MacKenzie and
 Dennis N. Powers....Novi

CHARTER TOWNSHIP OF MILFORD
1100 Atlantic, Milford 48381-2000

Phone (248) 685-8731 FAX (248) 685-9236

Supervisor James F. Caswell
 Clerk (Phone (248) 685-8731) Colleen Schwartz
 Treasurer Mary Jane Cagney
 Trustees Norman D. Bourns
 Randal K. Busick
 Donald D. Green
 Brien R. Worrell
 Chief of Police Wayne Walli
 Fire Chief Rex S. Martin
 Assessor Oakland County Equalization Division
 Attorney Thomas J. Connelly
 Building Inspector Timothy C. Brandt
 Civil Engineer Hubbell, Roth and Clark, Inc.
 District Court Judges (52nd-1st) Michael Batchik, Brian W. MacKenzie and
 Dennis N. Powers....Novi

TOWNSHIP OF NOVI
P.O. Box 924, Northville 48167

Supervisor (Phone (248) 348-0365) Raymond Schovers
 Clerk (Phone (248) 349-1964) Cara Bennett
 Treasurer (Phone (248) 348-2950) Robert Peterson
 Trustees Bruce Lowell
 Todd Mossoian
 Chief of Police Michigan State Police
 Fire Chief Arthur R. Lenaghan
 Assessor Oakland County Equalization Division
 District Court Judges (52nd-1st) Michael Batchik, Brian W. MacKenzie and
 Dennis N. Powers....Novi

CHARTER TOWNSHIP OF OAKLAND
4393 Collins Road, Rochester 48306-1670
 Phone (248) 651-4440 FAX (248) 651-7340

Supervisor Joan M. Buser
 Clerk (Phone (248) 651-4440) Carolyn L. Phelps
 Treasurer Sharon L. Creps
 Superintendent/Manager James V. Creech
 Trustees Dominic Abbate
 Amy Boltz
 Marc H. Edwards
 Susan L. Hoffman
 Chief of Police Oakland County Sheriff Department
 Fire Chief William Benoit, Jr.
 Assessor Oakland County Equalization Division
 Attorneys Secrest, Wardle, Lynch, Hampton, Truex and Morley
 Building Director William Benoit, Jr.
 Civil Engineer Land Tech, Inc.
 District Court Judges (52nd-3rd) Ralph H. Nelson, Julie A. Nicholson and
 James P. Sheehy....Rochester Hills

CHARTER TOWNSHIP OF ORION
2525 Joslyn Road, Lake Orion 48360
 Phone (248) 391-0304 FAX (248) 391-9984

Supervisor Colette M. Dywasuk
 Clerk (Phone (248) 391-0304 Ext. 104) Jill D. Bastian
 Treasurer James Marleau
 Trustees Burke R. Cueny
 Richard L. Tomczak
 JoAnn Van Tassel
 Eric S. Wilson
 Chief of Police Oakland County Sheriff Department
 Fire Chief Jeffrey D. Key
 Assessor John Attwell
 Attorneys Secrest, Wardle, Lynch, Hampton, Truex and Morley
 Building Official Thomas H. Berger
 Civil Engineer Orchard, Hiltz and McCliment, Inc.
 District Court Judges (52nd-3rd) Ralph H. Nelson, Julie A. Nicholson and
 James P. Sheehy....Rochester Hills

CHARTER TOWNSHIP OF OXFORD
18 West Burdick Street, P.O. Box 3, Oxford 48371-0003
 Phone (248) 628-9787 FAX (248) 628-8139

Supervisor E. Greg Gilbert
 Clerk (Phone (248) 628-9787) Clara J. Sanderson
 Treasurer Joseph G. Ferrari
 Trustees Susan Bellairs
 Shirley Clancy
 Patricia Fitchena
 Bradford C. Jacobsen
 Chief of Police Gary Ford
 Fire Chief Jack LeRoy
 Assessor Oakland County Equalization Division
 Attorney Gary R. Rentrop
 Building Inspector Michael C. Darling
 Civil Engineer Rowe Engineering, Inc.
 District Court Judges (52nd-3rd) Ralph H. Nelson, Julie A. Nicholson and
 James P. Sheehy....Rochester Hills

TOWNSHIP OF ROSE

204 Franklin Street, Holly 48442

Phone (248) 634-7551 or (810) 750-5220 FAX (810) 750-5224

Supervisor Chester W. Koop
 Clerk (Phone (810) 750-5220) Alison K. Kalcec
 Treasurer Joyce V. Slaughter
 Trustees Clarence O. Gordon
 Alfred Lopez
 Constable Emile Bair
 Chief of Police Michigan State Police
 Fire Chief Roger W. Caster
 Assessor Sue Weishuhn
 Attorneys Booth Patterson, P.C.
 Building Inspector David Schang
 Civil Engineer Edward A. Salter
 District Court Judges (52nd-1st) Michael Batchik, Brian W. MacKenzie and
 Dennis N. Powers....Novi

CHARTER TOWNSHIP OF ROYAL OAK
21075 Wyoming Avenue, Ferndale 48220

Phone (248) 547-9800 FAX (248) 547-1415

Supervisor Jerry L. Saddler
 Clerk (Phone (248) 547-9804) Gwendolyn W. Turner
 Treasurer Cynthia A. Phillips
 Trustees David Ford
 Cary Junior
 Frank Miles, Jr.
 Francine Thurman
 Chief of Police John L. Gatewood
 Fire Chief Tyrone C. Scott
 Assessor Oakland County Equalization Division
 Attorney Bloomfield Law Center
 Building Inspector Dan Murray
 District Court Judges (45B) Marvin F. Frankel and Benjamin J. Friedman
Oak Park

TOWNSHIP OF SOUTHFIELD**18550 West Thirteen Mile Road, Southfield Township 48025-5262**

Phone (248) 540-3420 FAX (248) 540-3427

Supervisor Raymond E. Mills
 Clerk (Phone (248) 540-3420) Sharon Tischler
 Treasurer Delores Aebersold
 Trustees John E. Breen
 I. Jack Fahlen
 Richard N. Holloway
 Whit Jones
 Chief of Police Beverly Hills Public Safety
 Fire Chief Beverly Hills Public Safety
 Assessor Oakland County Equalization Division
 Attorney Gerald A. Fisher
 District Court Judges (46th) Stephen C. Cooper, Bryan H. Levy and
 Susan M. Moiseev....Southfield

CHARTER TOWNSHIP OF SPRINGFIELD**650 Broadway, P.O. Box 1038, Davisburg 48350-1038**

Phone (248) 634-3111 or (248) 625-4802 FAX (248) 634-2316

Supervisor Collin W. Walls
 Clerk (Phone (248) 625-4802) Nancy Strole
 Treasurer Lois J. Stiles
 Trustees Margaret A. Bloom
 Elaine Field-Smith
 Richard D. Miller
 Dennis J. Vallad
 Chief of Police Oakland County Sheriff Department
 Fire Chief Charles M. Oaks
 Assessor Greg F. Zamenski
 Attorney Gregory K. Need, P.L.L.C.
 Building Inspector Derek Place
 Civil Engineer Orchard, Hiltz and McCliment, Inc.
 District Court Judge (52nd-2nd) Gerald E. McNally
Clarkston

CHARTER TOWNSHIP OF WATERFORD
5200 Civic Center Drive, Waterford 48329-3773

Phone (248) 674-3111 FAX (248) 674-8811

Supervisor Katherine G. Innes
 Clerk (Phone (248) 674-3111 Ext. 208) Betty Fortino
 Treasurer Dee A. Minton
 Trustees Todd T. Birkle
 Paul E. Deni
 Bette O'Shea
 Jean A. Scott
 Chief of Police Paul Vallad
 Fire Chief David Yarber
 Assessor Donald Wood
 Attorneys Secrest, Wardle, Lynch, Hampton, Truex and Morley
 Building Inspector Douglas Bradley
 Civil Engineer Douglas Bradley
 District Court Judges (51st) Kenneth H. Hempstead and Phyllis C. McMillen

CHARTER TOWNSHIP OF WEST BLOOMFIELD

4550 Walnut Lake Road, P.O. Box 250130, West Bloomfield 48325-0130

Phone (248) 682-1200 FAX (248) 682-3788

Supervisor Jeddy Hood
 Clerk (Phone (248) 683-0848) Sharon A. Law
 Treasurer Denise D. Hammond
 Trustees Allen Adelberg
 Stuart Brickner
 Raymond R. Holland
 Deborah Macon
 Chief of Police Ronald D. Cronin
 Fire Chief Carl T. Borg
 Assessor Russ Galvin
 Attorneys Secrest, Wardle, Lynch, Hampton, Truex and Morley
 Hemming, Polaczyk and Cronin, P.C.
 Building Director Phil Gentile
 Township Engineer Gary Mekjian
 District Court Judges (48th) Edward Avadenka, Gus Cifelli and
 Kimberly Small....Bloomfield Hills

CHARTER TOWNSHIP OF WHITE LAKE
7525 Highland Road, White Lake 48383-2900

Phone (248) 698-3300 FAX (248) 698-3351

Supervisor Mirl J. Spencer
 Clerk (Phone (248) 698-3300 Ext. 7) Bonnie L. Elliott
 Treasurer Beverly J. Spoor
 Trustees Forrest Jay Brendel
 Carol J. Burkard
 Cathy Morgan Hall
 Ronald C. Voorheis
 Chief of Police Ronald N. Stephens
 Fire Chief Richard Rayburn
 Assessor Kathy M. Boyea
 Attorneys Adkison Need, P.L.L.C.
 Building Inspector Darlene R. Waldrop
 Civil Engineer Johnson and Anderson, Inc.
 District Court Judges (52nd-1st) Michael Batchik, Brian W. MacKenzie and
 Dennis N. Powers....Novi

VILLAGES

VILLAGE OF BEVERLY HILLS

18500 West Thirteen Mile Road, Beverly Hills 48025

Phone (248) 646-6404 FAX (248) 646-3703

President	Elaine T. Kennedy
Clerk	(Phone (248) 646-6404) Ellen E. Marshall
Treasurer	Colleen Wayland
Director of Public Safety	Karl M. Woodard
Assessor	Oakland County Equalization Division
Attorney	Thomas J. Ryan, P.C.
Manager	Tamara O'Brien Hanlin
District Court Judges (46th)	Stephen C. Cooper, Bryan H. Levy and Susan M. Moiseev....Southfield

VILLAGE OF BINGHAM FARMS

30400 Telegraph Road, Suite 328, Bingham Farms 48025

Phone (248) 644-0044 (9:00 a.m. - 1:00 p.m.) FAX (248) 644-3254

President	Maryjane Bauer
Clerk	(Phone (248) 644-0044) Kathryn P. Hagaman
Treasurer	Patricia Beach
Chief of Police	Edward A. Glomb
Assessor	Oakland County Equalization Division
Attorney	Gerald A. Fisher
District Court Judges (46th)	Stephen C. Cooper, Bryan H. Levy and Susan M. Moiseev....Southfield

VILLAGE OF FRANKLIN

32325 Franklin Road, Franklin 48025

Phone (248) 626-9666 FAX (248) 626-0538

President	James A. Pikulas
Clerk	(Phone (248) 626-9666) Ann Ramsey
Treasurer	Joseph C. Brozic
Chief of Police	Edward A. Glomb
Assessor	Oakland County Equalization Division
Attorney	John Staran
Administrator	Jane Bais-DiSessa
District Court Judges (46th)	Stephen C. Cooper, Bryan H. Levy and Susan M. Moiseev....Southfield

VILLAGE OF HOLLY

202 South Saginaw Street, Holly 48442-1689

Phone (248) 634-9571 FAX (248) 634-4211

President	Jeff Miller
Clerk	(Phone (248) 634-9571) Marsha Powers
Treasurer	Marsha Powers
Chief of Police	Gregg Hansmeier
Assessor	Gregg MacAlpine
Attorney	Richard J. Figura
Manager	Mark Abeles-Allison
District Court Judge (52nd-2nd)	Gerald E. McNallyClarkston

VILLAGE OF LAKE ORION

37 East Flint Street, Lake Orion 48362

Phone (248) 693-8391 FAX (248) 693-5874

President	Carl A. Cyrowski
Clerk	(Phone (248) 693-8391) Arlene M. Nichols
Treasurer/Finance Director	Dorothy Zarzecki
Chief of Police	James R. Leach, Sr.
Assessor	John Attwell
Attorney	Thomas P. McKenney
Manager	Melanie D. Purcell
District Court Judges (52nd-3rd)	Ralph H. Nelson, Julie A. Nicholson and James P. Sheehy....Rochester Hills

VILLAGE OF LEONARD

28 East Elmwood Street, P.O. Box 789, Leonard 48367-0789

Phone (248) 628-7380 FAX (248) 628-8673

President Eugene A. Mallia, Jr.
Clerk (Phone (248) 628-7380) Cindy Oehler
Treasurer Judith Verse
Assessor Janice Ferguson
Attorney Phillip G. Adkison, P.L.L.C.
District Court Judges (52nd-3rd) Ralph H. Nelson, Julie A. Nicholson and
James P. Sheehy....Rochester Hills

VILLAGE OF MILFORD

1100 Atlantic, Milford 48381

Phone (248) 684-1515 FAX (248) 684-5502

President Christopher B. Smith
Clerk (Phone (248) 684-1515) Deborah S. Frazer
Treasurer Becky J. Jacques
Chief of Police Wayne Walli
Assessor Oakland County Equalization Division
Attorney Thomas J. Connelly
Manager Arthur Shufflebarger
District Court Judges (52nd-1st) Michael Batchik, Brian W. MacKenzie and
Dennis N. Powers....Novi

VILLAGE OF ORTONVILLE

395 Mill Street, P.O. Box 428, Ortonville 48462-0428

Phone (248) 627-4976 FAX (248) 627-3719

President Susan K. Bess
Clerk (Phone (248) 627-4976) Cynthia A. VanMegroet
Treasurer Cynthia A. VanMegroet
Chief of Police Oakland County Sheriff Department
Assessor Cynthia A. VanMegroet
Attorney Gerald A. Fisher
Manager Peter E. Auger
District Court Judge (52nd-2nd) Gerald E. McNally
....Clarkston

VILLAGE OF OXFORD

22 West Burdick, P.O. Box 94, Oxford 48371

Phone (248) 628-2543 FAX (248) 628-7030

President Susan K. Bossardet
Clerk (Phone (248) 628-2543) Rose M. Bejma
Treasurer Linda K. Smith
Chief of Police Gary L. Ford
Assessor Oakland County Equalization Division
Attorney Robert L. Bunting
Manager Vacant
District Court Judges (52nd-3rd) Ralph H. Nelson, Julie A. Nicholson and
James P. Sheehy....Rochester Hills

VILLAGE OF WOLVERINE LAKE

425 Glengary Road, Wolverine Lake 48390-1404

Phone (248) 624-1710 FAX (248) 624-3536

President Edward Sienkiewicz
Clerk (Phone (248) 624-1710) Rita L. Irwin
Treasurer Frances A. Barber
Chief of Police Joseph George
Assessor Wynn Berry
Attorney Thomas J. Connelly
Administrator Sharon A. Miller
District Court Judges (52nd-1st) Michael Batchik, Brian W. MacKenzie and
Dennis N. Powers....Novi