

State finance axe cuts city, school budgets

Statewide budget blues are bad news for the budgetary pictures in both the City of Novi and Novi Schools, but local officials still are uncertain exactly how bad the situation is.

City and school officials do know that Governor William G. Milliken's recently announced reductions in the state budget have left them wondering if they will be able to balance their respective budgets this fiscal year.

In the governor's latest round of budget cuts a total of \$288.5 million was slashed to balance the state's budget.

Assistant City Manager Alex Allie reported that the governor has cut two programs affecting cities — \$9.5 million in state shared revenue to city's was taken in one blow and \$3.5 million was

axed from a second state aid program. Locally, Allie expects to see the city lose \$15,000 to \$20,000 in general fund revenues as a result of the decrease in state shared revenues.

The city budgeted \$600,000 in state shared revenues — a figure city officials thought would be on the low side when the budget was drafted.

"We thought we were being pessimistic when we budgeted \$600,000 and now we won't even be getting that much," Allie said.

Based on the latest available data, Allie believes the maximum amount that Novi could lose is \$20,000. But state aid could be reduced another five percent if the economy does not recover, he estimated. In the end, the total reduc-

tion will be based upon the revenue the state takes in.

Allie said it may be the end of fiscal 1980 before the city is sure how much state sales tax will be returned locally. Figures on the local share of income tax to be received may be available earlier since that allocation is figured on the calendar year, Allie said.

City officials have not started a search for places to cut the budget, Allie said. Right now city officials are pinning their hopes on revenue sharing funds from the federal government.

"We won't go back through the budget until we learn the fate of federal revenue sharing. We're counting on that to stabilize the budget. If that's rejected by Congress it's back to the

drawing board," he said.

The city did not include federal revenue sharing funds in its anticipated revenues for the current fiscal year since legislation authorizing those allocations expired in October and there was no guarantee that Congress would reinstate the program.

However, federal revenue sharing has passed the U. S. House of Representatives and is now awaiting approval by the Senate, according to Allie.

Meanwhile, school officials are reeling from the \$65 million reduction in revenues to local school districts which comes on top of \$158 million in aid to schools already slashed from the budget earlier this year.

Superintendent Robert Piwko said

school officials have been unable to pin down exactly how much Novi Schools stand to lose.

"We just don't have anything specific, nothing is confirmed," Piwko said.

Projections of how individual school districts will be affected are flying fast and furiously, however.

Piwko said that from early projections estimates were made that Novi Schools could lose up to \$100,000 in state aid.

To demonstrate the uncertain state which the budget cuts have generated, Piwko noted that within a matter of hours Monday he received conflicting information on the size of the cuts.

Late Monday the superintendent heard that school districts such as Novi

which do not get state aid on a per student basis — known as out-of-formula districts — face a 75 percent cut in categorical aid. Categorical aid is state reimbursement for programs such as transportation and vocational education.

He went on to report that one set of formulas which he heard early Monday showed the state reimbursement for transportation might be cut 47 percent, vocational education would be reduced 24 percent, special education would be reduced 18 percent, community education reimbursements would be totally eliminated and state funds for professional development would be slashed 31 percent.

"We're not sure what it all means t," Piwko said.



Another good deed

Surrounded by canned goods donated by concerned Novi citizens, Scout Jim Young stands in the midst of food that will be packed up and delivered to eight needy families in the area in time for Thanksgiving, thanks to Novi-Northville Fish and dozens of Novi Cub and Boy Scouts. Jim, who contributed to

Fish's annual food drive by sending out the troops to collect groceries, polished off the last requirement for attaining an Eagle Scout badge by coordinating the project. Story on Novi-Northville Fish can be found in Modern Living, page 1-B. (Photo by John Galloway)

Auditors give city top budget grades

Novi has ended the 1979-80 fiscal year in the black — with a fund balance of \$348,000 and a report from the auditors that the city books are in good order.

Accountant Thomas D. Doescher of Plante & Moran had no specific recommendations for improving the city's accounting methods and in fact reported that Novi's books are "in as good shape as any community we audit."

In addition to reporting that the books are in good order, Doescher said the city is in good financial position.

"You had a good year. You lived within your budget and there's a small fund balance to help you through next year," Doescher said. "Next year could be tough financially, but you will be the benefactor's of the 1980 census. So overall you should be in good financial shape."

A summary of the audit showed the city took in more than \$3.4 million in general fund revenues in the past fiscal year. General fund revenues primarily are generated from property taxes.

This year the city received approx-

imately 48 percent of its revenue from property taxes, 17 percent from state shared revenues and 10 percent in federal revenues. Licenses and permits made up 8 percent of the city's revenues, and interest earnings on investments comprised 10 percent of the city's revenues.

General fund expenditures, which include monies spent directly on services to local taxpayers, totalled more than \$3.2 million.

The largest city expenditure was for police and fire protection. Some 51 percent of the budget or approximately \$1.6 million was spent for the public safety departments.

The second largest cost to the city was \$555,000 for general administration, which includes departments which indirectly provide city services such as finance, assessing and the city manager's office.

The difference between the general fund expenditures and general fund

Continued on 11-A

Jury acquits Novi man of first degree murder

A jury has found William W. Curtner, 28, of Novi, not guilty of first degree murder in connection with the January shooting death of his roommate.

After three hours of deliberation the jury returned a not guilty verdict to Oakland County Circuit Court Judge Robert Webster and Curtner subsequently was released.

Testimony in the case was heard throughout last week.

Court Services Officer Corporal William Brown reported that the jury's not guilty verdict was based on the belief that when Curtner fired the fatal shot he had been trying to protect another roommate from an attack by the man who was killed.

Andrew Lalomia, 24, of 21150 Old Novi Road was killed when he was shot through the neck with a 20 gauge "slug round" shot gun.

Brown said that in the jury's deliberations they requested a typed copy of the elements of each of the charges under which they could have prosecuted Curtner.

The focus of their deliberations centered on a paragraph included in a high misdemeanor charge which described an innocent person as one who was excited and could not determine how much force was necessary to protect another and therefore could not be held responsible for his actions, Brown said.

Brown said the judge and prosecutor talked with the 12 member jury after the trial and determined the jury had reached its decision based on the interpretation of that portion of the law.

According to testimony in the trial, the shooting apparently resulted from a disagreement regarding financial arrangements in the home shared by three men.

Reportedly the disagreement ensued throughout the day of the shooting. Defense witnesses said that when the shooting occurred, Lalomia was trying to strangle roommate Carl Baker.

Baker told the court he thought his roommate was being choked to death, according to Brown.

Prosecution witnesses said it would have been impossible for Baker to have been strangled if Lalomia were gripping him in the manner in which the incident was described to police. The grip

would have created some discomfort, but would not have been fatal, according to prosecution testimony.

They further noted that although defense testimony was to the effect that Baker could not swallow solid food for several days after the incident, he did not seek medical treatment for the neck injury.

Police also maintained that if he had been strangling his roommate in the fashion described to police the deceased would have had powder burns on his arm from the blast.

Other prosecution testimony revealed that after Lalomia was shot, but before police could investigate the crime scene, a knife was placed in Lalomia's left hand to make it appear as if a struggle had ensued. Lalomia was right-handed, witnesses testified.

The defense attorney said in opening statements that his client had "foolishly" placed the knife in his roommates' hand.

Jurists had the option of finding Curtner either not guilty, guilty of first or second degree murder, manslaughter or reckless and careless use of a firearm.

Options were open to the jury because the man initially was arrested on an open charge of murder. In district court he waived examination and was bound over to Oakland County Circuit Court on a charge of first degree murder.

Flea market owner threatens suit

Novi's new Master Plan for Land Use Development — which has not yet been officially adopted — is already facing its first threat of a legal challenge.

Gabriel Glantz, owner of the six-acre parcel on which the Walled Lake Flea Market is presently located, told the Novi Planning Board last week that he strongly opposes plans to designate his property on the master plan for single-family residential development.

"I'm convinced that this type of change on the master plan would reduce the value of our property 90 percent or more," said Glantz.

"The property has been used for commercial purposes since 1924 when it was the Walled Lake Casino and Amusement Park. It's been zoned commercial

since 1945, and I've been paying taxes on it as commercial for the past 12 years.

"If you go through with your plans to change it to a residential designation on the master plan, I will have to take some kind of step as early as possible to preserve our rights," he continued.

"The proposed action is so clearly unconstitutional, arbitrary and confiscatory, I don't believe there would be much to talk about in court," he added.

Glantz also suggested that the planning board had decided to designate his property as residential on the master plan because "it's only hearsay, but I understand that some council member has an ax to grind against me and my property."

Glantz did not indicate which council member he feels has "an ax to grind." Glantz and the city have been involved in several law suits over the past several years.

The decision to designate the 6.25 acre Flea Market for residential development was made at the planners' November 12 session.

Planning Consultant Charles Cairns previously had proposed that the Glantz parcel be designated on the master plan for a convenience commercial shopping center.

But the designation was challenged by the planners who maintained that location of a convenience center on the Glantz property would have a negative impact on both Walled Lake and traffic

on Thirteen Mile, East Lake Drive and Novi Road.

Planners ultimately decided to remove all non-residential designations north of 12½ Mile from the master plan and replace them with a single-family residential designation. The action was taken in spite of warnings from Cairns that it might be difficult to defend in court in light of existing commercial uses on the west side of Novi Road in the Thirteen Mile area.

"From a planning standpoint, I would personally prefer to see the entire area go residential because of the potential for strip commercial development that exists with the existing designations," said the planning consultant.

Cairns added, however, that the city's chances of defending a residential designation on the master plan for the Thirteen Mile/Novi Road area against a legal challenge "are modest."

In registering his opposition to the proposed residential designation, Glantz asked the planners last week to review its decision before adopting the master plan.

"My dream has always been that some big corporation would want to lease the property for an office use," he said.

"Ever since the opening of Twelve Oaks, rarely a week goes by that I don't get calls from people interested in using the property."

Glantz also said he has rejected bonafide offers from a "7-11 type store" and a credit union who wanted to utilize portions of the 6.25 acre site. "I'm not interested in segmenting the property

Continued on 11-A

Schools set up millage committee

Interested citizens are being sought to serve on a committee to review the financial needs of the Novi Community Schools and prepare a millage renewal proposal to come before the electors next school year.

Board members appointed to the committee include Trustees Joel Colliau, Robert Schram and Ron Milam. An open invitation has been extended to local citizens interested in serving on the committee, and board members also have been asked to submit the names of citizens willing to serve on the committee.

Novi is facing the expiration of 10.5 mills, or approximately one-third, of its operating millage.

The Novi Schools currently levy a total of 34.94 mills. The schools levy 27.94 mills for operations and seven mills for debt retirement.

Previously, voters have approved the levy of 23.5 mills for operations of the school district and 7.1 mills to repay debts incurred through construction of Novi High School and other capital improvement projects such as Novi Woods Elementary.

The millage is due to expire with the December 1980 tax collection.

Superintendent Robert Piwko explained the committee will determine the tentative millage needs for the school district in the 1981-82 school year.

Committee members will be looking at the district's budget and Michigan's financial picture in an attempt to get a handle on the district's millage requirements, Piwko said.

Colliau said he believed the committee also should study the long-range financial needs of the school district and develop figures for a three-year period.

Board President Sharon Pelchat said she would prepare a formal charge for the committee which outlines the group's duties and present it at the first meeting of the group — tentatively scheduled for December 2 at 7:30 p.m. in the school administration building on Taft Road.



Pick up your phone Saturday and you can save 10%. Place your ad between 8:30 A.M. & 12 Noon.

Northville— 348-3022
Novi— 348-3024
Walled Lake— 669-2121
South Lyon— 437-4133
Brighton— 227-4436
Howell— 548-2570

To reduce book thefts

Library security system sought for Novi High School

Purchase of a security system to cut down on the number of books being stolen from the Novi High School library has been recommended to the board of education.

Librarian Dolores Gerhardt told the school board last week that 540 books were stolen during the 1979-80 school year — seven percent of the total number of volumes and 24 percent of the new books.

Gerhardt said she was unable to find any high schools in neighboring districts comparable in size to Novi High School but that Lakeland High School in the Huron Valley District was the size of Novi when it installed a security system several years ago.

The librarian noted that the security system is being recommended as a last resort. "We've tried various ways to protect our collection, but they didn't cut our losses," Gerhardt told the board.

"Districts which use the system claim it's cut their losses 90 percent," said Gerhardt. "Some libraries say their losses are so minimal that they've stopped taking inventory."

"It will stop the kids who really don't want to steal books. Those who want to steal them will still steal the books," she said.

In order to avoid the Check Point system, a student would literally have to tear up the book to remove the electronically activated disk, Gerhardt said.

She said the security system would cut down on the number of students who simply don't take time to check out a book.

"It will stop the kids who really don't want to steal books. Those who want to steal them will still steal the books," she said.

She added that she believes most books are taken out of negligence. She went on to say that the losses of library books each year that "Novi has to be loaded with books that belong to this library. Occasionally we have kids who bring back a grocery bag full of books."

She noted that the number of stolen books has made it difficult to build a good collection. She has refrained from buying new books because of the expense.

Trustee Robert Schram said he believes installation of a security system would pay for itself in one year, but he opposed the installation of more than one entrance and exit gate.

WALTER A. GOODELL, D.D.S. Now open for family dentistry Located at 600 East Grand River Brighton, MI. In the Brighton Travel Building

THE NOVI-WALLED LAKE NEWS... (Small text listing contact info and details)

Novi agrees to join sewer extension study

A study to determine the need for a sewer arm which could improve sewer service to a small area in the southeast corner of Novi (Eight Mile/Haggerty Road area) will be undertaken as a result of recent action by the city council.

Council members voted 6-0 to enter into an agreement with Wayne County which calls for Novi, Northville Township and Livonia to participate in a study of sewage system needs. All three communities could be served by a sewer line along Haggerty Road.

Construction of the sewer along Haggerty Road would permit sanitary sewer lift stations to be eliminated and replaced with a gravity-flow sewer line. Gravity sewer lines are considered a more effective method of transporting sewage.

Surprise!



You could win a \$1,000,000 grand prize!

Here it is! "Surprise Package," the new instant lottery game that's loaded with fun, excitement—and millions of surprises. Just rub, and if you get three...

Laurel FURNITURE DIRECTOR'S CHAIR The Price \$2288 100% Polyester vat-dyed fabric. White baked enamel steel frames. 3 colors.

NOVI STANDARDS HAPPY HOUR Mon-Fri 6 pm-9 pm Sat. 7 am-5 pm 5 qts. 10w30 ATLAS OIL FILTER LUBRICATION CHECKS P/S FLUID TIRES TRANS FLUID AIR CLEANER RADIATOR DIFF. ONLY \$9.99

Wood-Center Pharmacy GRAND OPENING SPECIALS MAALOX LIQUID \$1.69 KERI LOTION \$2.59 COMTREX TABLETS \$1.89 10% OFF YOUR NEXT PRESCRIPTION NOV ONLY ENDS 12/15/80

More council guidance needed

Tucker admits charter violation

By STEPHEN CVENGROS Chairman Ken Tucker acknowledged that the Walled Lake Plan Commission did violate the city charter on one of two alleged charges made by the city council.

Tucker's admission directly related to Council Member Thomas Brookover's opposition to the commission's recent acquisition of an aerial map cabinet on the basis that it violated Walled Lake's charter.

minutes with areas the council should act on circled in red and a lack of comment concerning recommendations.

"I have the best secretary there in city hall. And she doesn't write cryptic minutes," Tucker responded to Brookover's comments. "I don't like it."

Antique Clocks REPAIRS & SALES NORTHVILLE Watch & Clock Shop 132 W. DUNLAP NORTHVILLE 1 Blk. N. of Main 349-4938

KEROSUN The good news in home heating. FOOTE GRAVELY TRACTOR West of Tall 348-3444 Mon-Fri 9-5 Sat. 9-12 16401 Grand River-Novi

1,000's of Gifts!!! All new and discounted! Save on all your Holiday Shopping Needs Toys, Clothing, Furniture, Sporting Goods, Guns, Jewelry and MUCH MORE!

DURACELL BATTERIES MAKE HOLIDAY FUN LAST LONGER SPECIAL AA 4 Pack \$2.99 C 2 Pack \$1.79 D 2 Pack \$1.79 9 Volt \$1.79

f/Stop COMPLETE PHOTO STORE 43220 Grand River Ave. 348-9355 Sign up today for basic photography, cibachrome printing, basic darkroom and figure photography classes.

THE Gratest Fireplace SHOP GET FREEDOM FROM COSTLY FUEL BILLS WITH AN ENERGY EFFICIENT WOOD BURNING STOVE. The FREEDOM FIREPLACE INSERT. This unit comes complete with 1 of 3 different size surrounds...

Brookover did not disagree with the adequacy or necessity of the cabinet. "It's nice," he told his colleagues, "but I have a problem with it. Mr. Donnelly is a plan commission member. He's concerned because it's there."

Tucker also took offense to comments made by Council Member Thomas Brookover to the News regarding receipt of "cryptic" copies of the plan commission's minutes.

Walled Lake told hike in sewer rates coming

Sewage disposal charges will increase 39 percent for Walled Lake residents beginning February 1, 1981.

Walled Lake residents receive sewer service through the Walled Lake-Novi Sewage Disposal System which is operated by the Oakland County DPW.

Dornan predicted the average bill in Walled Lake, currently totaling \$25 per unit quarterly, will rise to \$34.75 per unit quarterly come February.

When sewer rates increase in Walled Lake, the city will probably attempt to extend the higher rates to areas in neighboring communities which also use the sewage disposal facility.

FOR INFORMATION CALL CHET MILES Age 30 to 60! You may save big money on your auto insurance! Why not check with Farmers today!

NOTICE OF PUBLIC HEARING NOTICE IS HEREBY GIVEN that the Walled Lake Planning Commission will hold a Public Hearing at the Walled Lake City Hall, 1492 E. West Maple Road, Walled Lake, Michigan, on Tuesday, December 9, 1980, at 6:30 p.m. to consider several changes and additions to the CITY ZONING ORDINANCE.

Auto Insurance Costs GETTING YOU DOWN? Save money with Farmers... the best auto insurance buy in America today!

Guernsey FARMS DAIRY from Our Dairy to You for the Thanksgiving Holiday OLD FASHIONED HOLIDAY FAVORITES "Whipping Cream" "Egg Nog" "Ice Cream" "Butter" "Cheeses" 21300 Novi Rd., Northville 349-1466

R & M DEPT. STORE UNION LAKE MIDNIGHT MADNESS CHRISTMAS SALE OUR BIGGEST EVER 20% to 50% OFF EVERYTHING 5 HOURS ONLY

Coloring Contest Color this Picture and Bring it to... BARGAIN HUNTER'S CHRISTMAS SALE *Fabulous Toy Prizes* AGE CATEGORIES: 2-5, 6-8 9-11, 12-14 Detroit's Number One DISCOUNT CHRISTMAS SALE NOV. 28, 29 - 9 a.m. to 9 p.m. NOV. 30th - Noon to 6 p.m. Detroit Artillery Armory, 18000 W. 8 Mile Rd. Oak Park, Michigan

Wixom building department investigation requested

A Wixom developer has said he will request an investigation of alleged irregularities in the Wixom Building Department through the State Department of Labor — Bureau of Construction Codes.

Ed Coogan, president of Kelly Homes, said that he has made a verbal request for an investigation and is preparing to submit a written request. Specifically, Coogan has accused Wixom Building Inspector William Tyler of improprieties in obtaining proper inspections for construction of his own residence on Hillcrest Street in the Hickory Hills Golf and Country Club subdivision.

Construction Codes said that the request for an investigation will be reviewed and a determination made as to whether an investigation will be conducted.

Coogan's allegations are the latest development in a month-long dispute between the developer, city officials and residents in the Birch Park subdivision. In addition to charging that irregularities exist in the inspections of Tyler's home, Coogan also charged last week that no final occupancy permit was ever issued for Wixom City Hall and asked that all city departments and all council members be cited for every day that the building was occupied

without a permit. In the meantime, the city has issued Coogan five violations for occupying a building on Pontiac Trail without a certificate of occupancy.

Coogan moved his Kelly Homes' offices into the building after the building in which his offices formerly were located was destroyed by fire November 8. Police have said that the fire was caused by arson. A court date of December 4 has been scheduled to hear the charges filed by the city against Coogan.

Coogan's attempts to develop the lots by installing a dirt road and drainage met strong opposition from Birch Park residents who aired their complaints to the city council on several occasions.

The controversy began to heat up when Tyler issued Coogan a violation for moving into a new office on Pontiac Trail before obtaining a certificate of occupancy. In response to what he calls "harrassment" on the part of the city, Coogan lodged some charges of his own last week. Specifically, the Kelly Homes president charged that no final occupancy permit was ever obtained for Wixom City Hall and that there have

been irregularities in the inspections of Tyler's personal residence. City records show that a temporary occupancy permit for city hall was obtained January 9, 1978, but that a final occupancy permit has never been approved.

Coogan has asked that all city departments and council members be charged with a violation for every day that city hall was occupied after the six-month temporary permit expired on June 9, 1978. The alleged irregularities in the construction of Tyler's personal residence conducted by Bartimore were dated in September, 1980 — more than a month.

In addition to charging that it is improper for Tyler to conduct and sign inspections of his own home, Coogan also notes that the inspections allegedly conducted by Bartimore were dated in September, 1980 — more than a month.

Continued on 8-A

Wixom no longer top choice for new ethanol refinery

Wixom is no longer the top choice for construction of a \$100 million ethanol refinery.

Ypsilanti Township officials, on the other hand, are doing just about everything in their power to convince U.S. Ethanol to locate the proposed ethanol refinery in their community, according to Stawick.

Ypsilanti Township reportedly has guaranteed U.S. Ethanol some tax abatement for the proposed facility and also is working with company officials to secure adequate sewer and water utilities.

The township also is working with U.S. Ethanol on site plan review processes, according to Stawick. U.S. Ethanol received a \$500,000 grant from the U.S. Department of Energy in June to prepare a feasibility study for development of a refinery. The grant was offered throughout the

United States in an effort to develop alternate energy sources that will reduce the nation's dependence on foreign oil imports.

A total of 1,000 grant applications were submitted, and U.S. Ethanol's application was one of 99 approved for funding. U.S. Ethanol was the only Michigan company to receive a grant. Stawick indicated that the feasibility study will be completed sometime in January. If the study is accepted by the Department of Energy, the company will receive federal loan guarantees for 90 percent of the estimated \$100 million construction costs.

The plant will produce 50 million gallons of ethanol per year and will employ 150 people on three shifts, according to John Ambrose who is coordinating the firm's feasibility study.

If the feasibility study is approved, construction could begin as early as March 1981 and would take 12-18 months to complete, Ambrose said. The reluctance of Wixom officials to work closely with U.S. Ethanol is based on a variety of factors, not the least of which are the effects the proposed facility could have on the city's sewer system and water supply.

Since Wixom is not hooked up to Detroit water, local officials are concerned about the effects the plant could have on the water table.

Additionally, the city's wastewater treatment system is already under restrictions from the Department of Natural Resources, and local officials are concerned that the plant will be unable to handle an additional one million gallons of discharge per day. U.S. Ethanol's request for tax abatement also has run into some resistance from city officials. Mayor Assistant Stephen Bonczek noted recently that he sees no reason for granting tax abatement to a firm which has received \$500,000 grant from the federal government for its feasibility study and also

will receive federal loan guarantees for 90 percent of the project. Other Wixom officials have raised concerns about environmental aspects associated with the plant which will use coal as its primary energy source.

Ypsilanti Township, on the other hand, has access to Detroit water and adequate sanitary sewer facilities, according to Ambrose. Both the Wixom and Ypsilanti sites meet the company's needs for rail access as well as access to major highways.

"We haven't eliminated Wixom as a potential site," stated Stawick. "But at this point, we're getting a great deal of cooperation from Ypsilanti Township which just haven't received from officials in Wixom."

WALLED LAKE SECOND FRONT PAGE

Page 4-A THE NOVI NEWS—THE WALLED LAKE NEWS Wednesday, November 26, 1980

Dornan asks city to establish goals

Walled Lake City Manager J. Michael Dornan eagerly grabbed "the tiger by the tail" during his first city council meeting by requesting the development of city goals for the upcoming year. Dornan suggested city council members establish annual city goals and priorities as the first item in his initial manager's report to the city. "I'm requesting that council seriously consider developing a list of the goals and priorities that each council member wants to personally achieve over 1981," said Dornan. "I would like you to bring to myself and the city clerk goals we would like to undertake," Dornan continued. "We would have the staff tabulate them for your perusal." Dornan suggested that the establishment of goals would provide the city's staff and employees "with some type of solid direction." Input from the various council members will be the key to the success of Dornan's idea, which he speculated



Not everyone is looking forward to tomorrow's festive Thanksgiving Day parades, feasts and football games. Witness these feathered friends getting in their last farewells. Turkeys inevitably conjure up images of the family gathered around the table celebrating an American tradition dated back to the pilgrims. But what do turkeys have to say about all of this celebrating and festive holiday spirit? No thanks! (Staff photo by Jane Hale)

Sex bias: Civil rights agency examining allegations against Walled Lake

"As far as I'm concerned, I have not discriminated against anyone." — John Nail, DPW Superintendent

However, City Attorney Richard Poehlman said, "He (Nail) didn't make the comment." The union steward also stressed that testing for the position Ray sought had never before been done by Walled Lake's DPW. "I am a woman and believe that I was unfairly required to take a test, and then denied this position because of my sex," Law stated in a letter filed with MDCR. "We lost some federal money in the traffic division. That's going to affect us and we're (as a department) going to lose some people," Goodrich observed.

But Nail contended it is a general practice of the department to give a test when there is more than one applicant for a position. "If we have more than one person applying for a job — that's a practice," Nail said. The DPW superintendent said "outside people" are hired to fill a man's job. Law worked as a temporary laborer for Walled Lake from June through August of this year. It was during that period that she became aware of a full-time position. She applied for the open-

Continued on 8-A

Continued on 8-A

Group home proposed at Eight Mile site

A Utica corporation has applied for a license to operate a group home for the mentally retarded at 4777 Eight Mile Road in Northville Township. The license application notice sent to the township from the state Department of Social Services (DSS) is dated October 23. The newly-elected township board of trustees discussed the application at its November 20 meeting. The license application notice sent to the township from the state Department of Social Services (DSS) is dated October 23. The newly-elected township board of trustees discussed the application at its November 20 meeting. Nichols, whose non-profit corporation operates 13 group homes in the state and three in the tri-county (Wayne, Oakland, Macomb) area, attended the meeting to answer questions concerning the operation. The township, as required by law, notified neighboring homeowners of the application and a handful appeared at the meeting to express their concerns. Betty Hancock, of 4265 Eight Mile Road, asked Nichols a rapid-fire series of questions about the qualifications of the workers who would be supervising the residents of the home and the operations of his corporation. The group home operator told Hancock the state requires workers to be over 18 years of age and have 120 hours of DSS training in CPR, behavior modification, and training the mentally retarded. He said the corporation also conducts its own training beyond that mandated by the state and that he attempts to exceed state requirements when hiring personnel. The house itself is owned by a private investor and would be leased to the non-



We Thank God For the many blessings we've had this year. Just to picture a few. May yours be blessed as well. Albright Photography 348-2248

CITY OF WIXOM NOTICE OF PUBLIC HEARING

Notice is hereby given that City of Wixom will hold Public Hearings on Community Development and Housing Needs (pursuant to U.S. Department of Housing and Urban Development's Community Block Grant Program (CDBG)). The second public hearing will be held at Wixom Municipal Center, 49045 Pontiac Trail, Wixom, MI 48096. November 25, 1980 — 8 p.m. December 9, 1980 — 8 p.m.

The first public hearing will be regarding the CDBG program and all interested citizens are invited to attend and submit views and proposals concerning potential projects. The second public hearing will be held to announce the Community Development projects to be submitted to Oakland County Community Development Division.

BACKGROUND

The primary objective of this program is "the development of viable urban communities, including decent housing and a suitable living environment and expanding economic opportunities, principally for persons of low and moderate income." The program consolidates several previous HUD programs, and is directed toward such objectives as:

- Elimination of slums and blight.
- Elimination of health, safety, and welfare hazards.
- Conservation and expansion of housing.
- Alleviation of economic distress.
- Expansion and improvement of community services.
- A more rational utilization of land and other natural resources.
- Reduction in isolation of income groups.
- Restoration and preservation of historic properties.

To meet these objectives, certain activities are allowed. Some examples are:

- Property acquisition.
- Certain public works and facilities projects.
- Rehabilitation projects.
- Preparing comprehensive community development plans.
- Economic development.

Some activities are not allowed. For example, facilities for which the funds cannot be used include:

- Stadiums and sport arenas.
- Schools.
- Transportation depots.
- Hospitals and nursing homes.

PUBLIC HEARINGS

Prior to submission of an application, the City is required by the Federal regulations to make this program known to the citizens.

- (1) "Provide citizens opportunity to participate in the development of the application."
- (2) Encourage submission of the citizens views and proposals particularly by those of low and moderate income."
- (3) "Provide timely responses to citizens proposals."
- (4) "Schedule hearings that encourage broad participation (citizen views in housing and community development particularly those of low and moderate income)."
- (5) "Provide adequate citizen information on the program."

However, "the citizen participation requirements... do not include concurrence by any person or group involved in citizen participation process in making final determinations concerning the findings and contents of the application. The sole responsibility and authority to make such final determination rests exclusively with the City of Wixom."

An opportunity to propose revisions, changes, or amendments will be provided later when the application is formally presented to City Council.

AGENDA:

- (1) Introduction (10 minutes): a. Mention of Public Notice of Hearing; b. Introduction of Chairperson and City representatives.
- (2) City of Wixom presentation (30 minutes).
- (3) Questions and answers dealing with City's presentation.

Published: Nov. 5 & 26, 1980 JUNE BUCK, CITY CLERK CITY OF WIXOM

30% OFF ALL WALLPAPER
No Freight Charge
50¢ per roll added to all orders less than Full Case (24 rolls)
Call in any pattern from any supplier to match our excellent wallpaper.
Open 9-5 Mon.-Sat., 11-3 Sun.
117 E. Main Street Northville 349-2323

Steven E. Blum D.O.
is pleased to announce the opening of his office for the practice of
Family and General Medicine
476-0035
39595 W. 10 Mile By Appt. 24 hour
Across from Providence Hosp. ans. service
Novi Center

Everything you need...
PLYMOUTH TOWNE APARTMENTS
Enjoy healthy, comfortable living in the beautiful new complex.
Open 9-5 Daily 12-3 Sat. & Sun. Now Taking Reservations Call or visit
Plymouth Towne Apartments
107 Haggerty Road Plymouth, MI 48170 (313) 459-3890
Map showing location near Plymouth Rd, Schoolcraft, and Edward River Drive.

OPEN FRI. NOV. 28 'TIL MIDNIGHT
Pocket Pleasers
SALE STARTS TODAY
MIDNIGHT MADNESS
20% to 50% OFF EVERYTHING!
Sweaters • Blazers
Cords • Jeans • Dresses
Just to name a few of our many items on sale.
SAVE NOW ON HOLIDAY GIFTS
Pocket Pleasers
1546 Union Lake Rd., Union Lake
Across from R & M Dept. Store
Hours:
Mon. - Sat. 9:30-8:30
Sun. 12-5
363-7622
WE FEATURE THESE SIZES:
2-15
6-20
14½-24½
36-46

County calls cuts probable for township sub-station

Continued from Walled Lake 1

adding that the cuts could concern the township payroll. Presently, three county-financed cir-

cle cars are stationed in Commerce. Sergeant Frank Mousier, also of the county sheriff's department, explained that the circle cars may be eliminated, thus reducing the

number of deputies in the township sub-station. Hubbell cleared what had become a muddled picture of the township's police protection.

Two weeks ago, Goodrich told The News that cuts in the township force were forthcoming due to financial difficulties. Goodrich said November 10 that the county sheriff's office had notified him of the cut and called the move "a matter of economy."

This announcement came on the heels of a defeated township proposal for added law enforcement personnel in Commerce. Goodrich totally denied any connection between the reduction and pressure toward the future passage of the proposal, which he anticipated would come before voters again in a special March election.

"Commerce only pays for six officers and we tried to subsidize the rest until Commerce could pay for them," Goodrich said. But following the elec-

tion, Goodrich was told by township officials, "the word was Commerce was pleased with the coverage it was paying for."

The advisory question to establish a special assessment district to pay for additional police protection failed 3,669 to 1,037 in the November 4 general election. Goodrich sees few answers in sight.

"The only resolution right now, that's financial, is that state law allows the township to levy up to five mills. Right now, they are levying zero. We're paid out of the township's general fund," Goodrich said.

"It is my understanding that the board made a promise it would not levy any taxes without voter support — and it's going to stick to that promise," he continued.

INTERNATIONAL WIDGELY INC.

Does this cartoon describe you? You're not alone!

Auto-Owners for Business Insurance

Same business and auto insurance... and permanent coverage during temporary absences.

Auto-Owners Business Insurance... Interception Insurance Policy... will protect you against loss of income when your responsibility is shut down for repairs, and loss of key employees because you can't afford to pay out when nothing's coming in.

So before you're burned, come to Auto-Owners. It can be the difference between going out of business... or staying in.

Over 38 Years Experience
108 W. MAIN NORTHVILLE

Auto-Owners Insurance
Life, Home, Car, Business. One name says it best.

C. HAROLD BLOOM 349-1252

Listen to the Auto-Owners John Doremus Radio Show.

28% OFF ALL WALLPAPER

No Freight Charge
50¢ per roll added to all orders less than Full Case (24 Rls)

Visit our Unfinished Furniture Department

When shopping for price... Don't forget quality! We take pride in our quality, service and price.

INTERIOR Latex From \$10.99 Gal.
Choose from 1500 Colors

20% OFF Treatments

Open Daily 10 to 8; Sat. 10 to 5

Green's CREATIVE HOME CENTER

107 N. Center (Next to Schrader's)
Northville 349-7110

You'll Love, Diet Centres

Simplest, easiest diet ever!
• Drink wine, eat Fudgesicles and much, much more!
• No fasting! • No contracts to sign!
• 10 first week registration, only \$4.00 weekly thereafter!

NEW CLASSES NOW AT NOVI HIGH SCHOOL
10 Mile & Taft
MONDAY 7:30 P.M. ROOM 109
Counselor: Rosie Teague - 349-8888

Meeting held at other locations
Call Us
548-7526 963-3438

CITY OF NORTHVILLE NOTICE TO BIDDERS

The City of Northville will receive sealed bids for Motor Vehicle Insurance until 11:00 a.m. on Monday, December 29, 1980, at the Northville City Hall, 215 W. Main St., Northville, MI 48167. Specifications are available at the Office of the City Clerk. The City Council reserves the right to accept or reject any or all bids, in whole or in part, and to waive any irregularities.

Joan G. McAllister
City Clerk

Pub. 11/26/80

CITY OF NORTHVILLE NOTICE TO BIDDERS

The City of Northville will receive sealed bids for Excess Liability Commercial Umbrella Insurance until 11:00 a.m. on Monday, December 29, 1980, at the Northville City Hall, 215 W. Main Street, Northville, MI 48167. Specifications are available at the Office of the City Clerk. The City Council reserves the right to accept or reject any or all bids, in whole or in part, and to waive any irregularities.

Joan G. McAllister
City Clerk

Pub. 11/26/80

Highland Lakes Shopping Center

Zarek's UNIVERSAL COIFFURES

Wants your children to celebrate the holidays in style

Thursday only
Boys'-10 years & under
Haircut, Shampoo & styled \$8.00

Girls'-10 years & under
Haircut, Shampoo & styled \$10.00

Ladies, Call for an appointment for manicuring
348-9290

The Energy Miser Is Moving See our new Discount Factory Outlet

Many new quality wood stoves and inserts to choose from plus a new line of accessories for your woodburning needs.

TAKE ADVANTAGE OF OUR NEW DISCOUNT PRICES Hurry While They Last!

Dec. 1, 1980-New Location
Energy Miser Discount Outlet at Brady Built Construction
27050 W. 8 Mile, Southfield, MI
3 bids, east of Grand River, 354-8250
10 minutes from Northville

THE ENERGY MISER Hq.
Open 7 Days 348-9360

CITY OF NORTHVILLE NOTICE TO BIDDERS

The City of Northville, Michigan will receive bids up to 11 a.m., Friday, December 12, 1980 for one (1) 1973 Dodge 800 Dump Truck for sale. Address bids to the Northville City Clerk, 215 W. Main Street, Northville, Michigan, 48167, in a sealed envelope bearing the inscription:

BID FOR 1 1973 Dodge 800 Dump Truck

At the close of bids, the bids will be opened in public. A decision on the bids will be made by the Northville City Council on December 15, 1980. The City Council reserves the right to accept or reject any or all bids.

The Dump Truck may be seen at the Public Works Yard Monday through Friday from 7 a.m. to 4 p.m.

Joan G. McAllister
City Clerk
Ted Mapes, Superintendent
Department of Public Works

Publish: 11-26-80

STRATFORD SWIVEL ROCKER

Beautiful Hercules Velvet
Reverse Seat Cushion
Many Colors to Choose From

Reg. \$319

\$179⁹⁵

TENPENNY Interiors
FINE FURNITURE 348-7174 Open Daily 10-8, Sun. 12-5

SHIATSU Relaxation Therapy

An ancient Japanese Art... Shiatsu is "pressure point" massage that results in a complete and satisfying relaxation.

By **MAYUMI**, our Japanese Masseuse

18.00-1 Hour By Appointment

SUN TANNING
suntique SALON
"Where the sun is always shining!"
349-6000

WORLD JEANS

We're back from vacation just in time for holiday savings

10% OFF STOREWIDE SALE

Sale includes 10% off our expert tailoring and alterations on ALL your clothing!

CALL 348-8560

Area Police Blotters

Man arrested on soliciting charges

In Novi

A 20-year-old Northville man was arrested on charges of accosting and soliciting after he allegedly propositioned a sales clerk at Twelve Oaks Mall.

Novi police are seeking warrants against Stoney L. Bruce. A New Hudson woman reported that she was approached by the suspect while she was working at the mall. He began talking about trucks, she said, and then offered to get her a cup of coffee.

When he returned with the coffee, his discussion turned to sex and he made progressively more expensive offers for sexual favors, according to reports.

The victims told police they met two men in the mall who offered to sell them some LSD. The youths agreed to talk with the men and arranged to meet them in the parking lot.

The two men allegedly showed them some marijuana cigarettes and "some acid" which the victims told police were not real drugs.

One of the suspects then pulled a gun from under the dash, falsely identified himself as a "Twelve Oaks narc" (narcotics officer) and demanded to see identification from the youths.

The suspect then removed \$14 from the wallet of the male victim and ordered the youths out of his car.

One of the suspects was described as a white male, 6-1, weighing 155 pounds with medium blonde hair and a mustache and beard. The other suspect was described as a white male, 6-1, weighing 180 pounds with long brown hair. Police also are seeking two white females in connection with the incident.

Both are approximately 25 years of age with long black hair.

Thieves took \$50 worth of goods from a home in the 2000 block of Dixon Road on November 14.

They apparently gained access through a rear door on the west side of the residence.

Taken in the heist were a \$50 microwave oven, a \$90 digital watch, an \$80 clock radio, a jewelry box and silverware.

Police said neighbors reportedly observed a suspicious red Vega with two white males in the area on the day of the break-in.

A break-in at a home in the 4100 block of Parkridge netted the thief \$300 worth of television sets.

The responsible party gained access by cutting a screen on the living room window on the north side of the building. Two televisions were taken, but nothing else was stolen, according to police.

A thief forced open the back door of a home in the 2900 block of Meadowbrook Road in a break-in which netted him a \$175 television set, according to police. Apparently nothing else was taken in the heist.

A Ford Maverick parked outside the Walled Lake Flea Market was maliciously damaged November 19, according to witnesses. However, the car struck a guide wire support pole. Police estimate she was travelling 52 miles per hour.

At the scene, Holzer told police she didn't remember anything about the accident and was transported to a hospital for medical attention, according to reports.

Meanwhile, an investigating officer allegedly noticed a bank envelope lying on the floor of the 1973 Chevy Camaro and picked it up because it looked like it was full of money, reports indicate. The policeman looked inside the envelope and saw a folded magazine page inside.

According to the officer, knowing that to be a common way of storing money, he unfolded the paper and found the controlled substance, later determined to be cocaine.

CITY OF NOVI NOTICE OF RESCHEDULED MEETINGS

Please take notice that the City Council has rescheduled the following meetings:

The regular meeting of December 1, 1980, has been rescheduled to December 8, 1980. The Regular Meeting of December 15, 1980, has been rescheduled to December 22, 1980. The Regular Meeting of January 5, 1981, has been rescheduled to January 12, 1981. The meetings are held at 8:00 p.m. EST, at the Novi Public Library, 45245 W. Ten Mile Road.

Geraldine Stipp,
City Clerk

A PRICELESS GIFT

Bausch & Lomb GIFT CERTIFICATE

For Bausch & Lomb SOFLENS (polymacon) Contact Lenses
It's a surprise for your eyes!

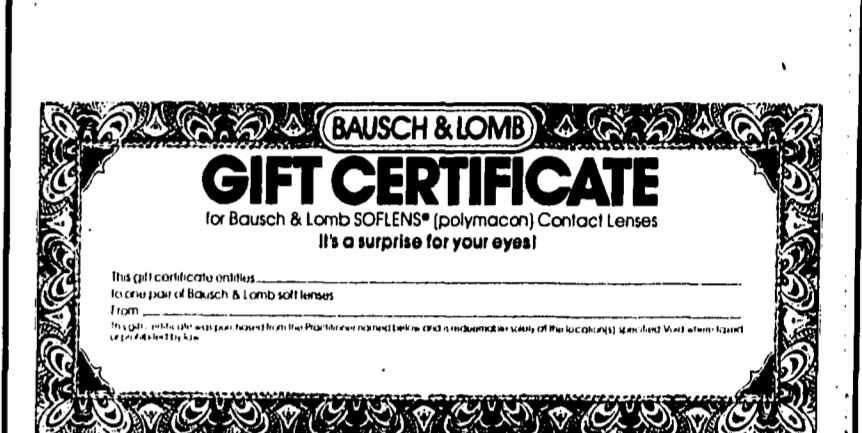

...Bausch & Lomb soft lens gift certificates! They can be worn city where except while swimming or sleeping. Ask us about Bausch & Lomb soft lens gift certificates, and ask our eye care professionals for complete information.

DR. JOHN SWANSON
435 N. PONTIAC TRAIL, WALLED LAKE
669-9040

ON Subscription Television

now available at
Don-Lot's T.V.

You can have "ON" T.V. installed for only \$19.95 with existing antenna or \$9.95 with purchase of new antenna PLUS reliable deposit

T.V. Antennas • Sold and Serviced at a price you can afford

Call Today 427-3910 or 427-3911

Just Coins, Inc. NEED CASH?

Call the Instant Money Co.

TOP CASH PAID WE ARE STRONG BUYERS OF COINS, EVERYTHING GOLD, ANYTHING SILVER, STAMPS, ESTATES, COLLECTIONS

We have in stock a full line of coins and supplies—stamps and supplies.

APPRAISALS—INVESTMENT COUNSELING

Certified Scales
348-8340

HOURS
Mon., Tues. 10-6
Fri. 10-9
Sat. 10-4

1039 Novi Rd., Northville

FRESH-FACE IRON-ON DECORATIVE PLASTIC LAMINATE
NEW BEAUTY FOR OLD KITCHENS

FREE IN-STORE CLINIC

SATURDAY, NOVEMBER 29th 10 A.M.-2 P.M.
FACTORY EXPERTS SHOW YOU "HOW-TO"

Cafe Doors
The right height to block cluttered areas from view while letting in air and light for a more spacious-looking decor. Will swing in either direction.

2'6" PAIR.....3570
2'8" PAIR.....3935
3'0" PAIR.....4125

PRICES SHOWN INCLUDE HARDWARE!

Call 474-4015 Call
FARMINGTON LUMBER

474-4015 32800 GRAND RIVER FARMINGTON Daily 8-6 Sat. 8-4

VISIT SANTA

Frídays, 6 to 9 p.m.
Saturday, 12 to 6 p.m.
Free Candy Canes
Pictures With Santa \$3.00

Santa is Located in KINNEY SHOES
in the convenient Grand River & Halstead Shopping Plaza Farmington

sponsored by the Farmington Jaycees & Jayettes and the Grand River & Halstead Shopping Plaza Merchants Association

The Tapered Suit by **Botany 500**

Botany introduces the athletic 8" drop suit SPECIALLY designed for wide shoulders and slim waists, which gives style and tailoring to compliment his build.

Sizes: 38 to 44
Reg. & Long

\$175

Open Thursday & Friday 11-9 p.m.

Lapham's Men's Shop

1400 Woodward Ave., Farmington, MI 48334
474-6677

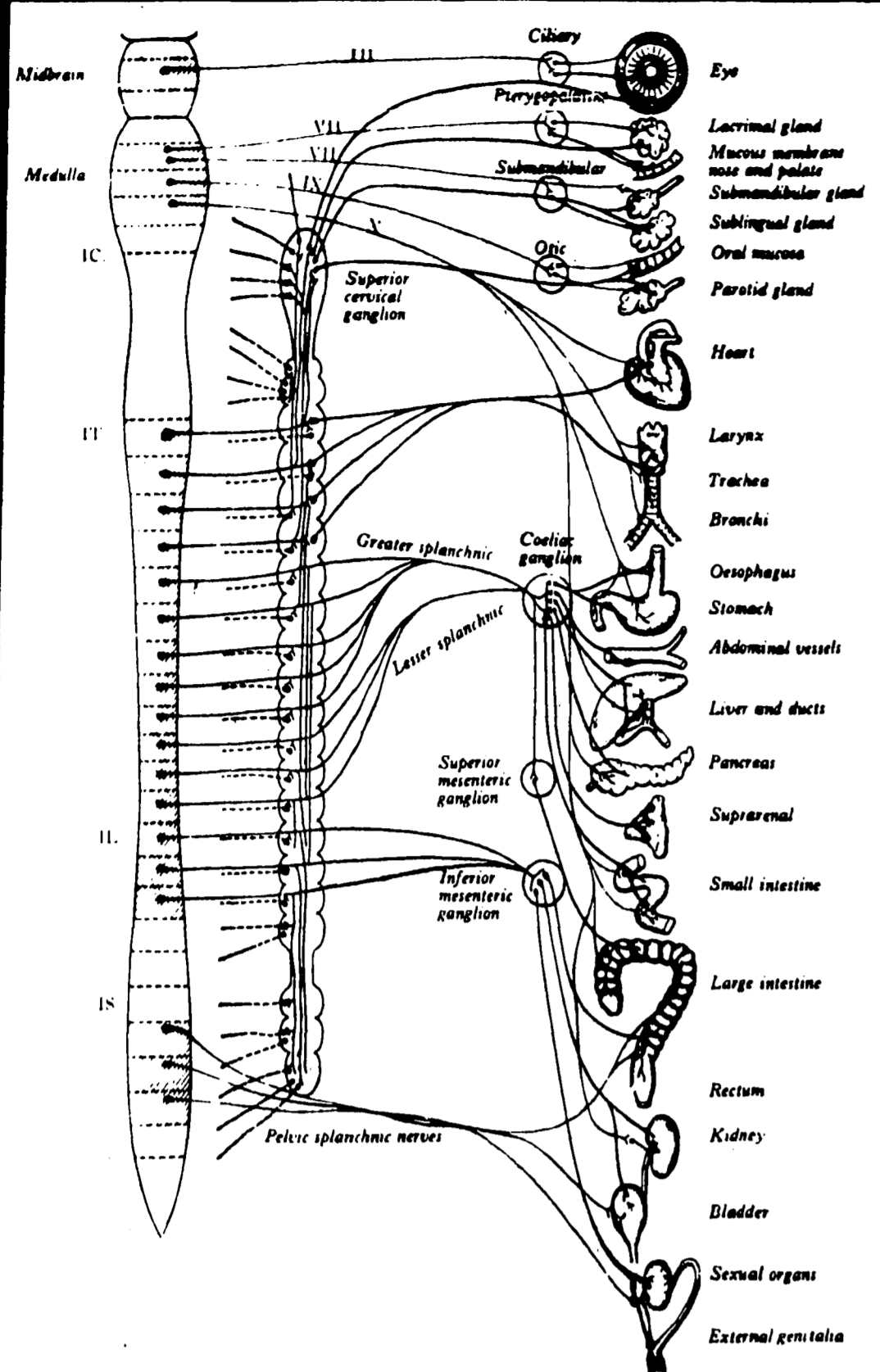

What is Chiropractic "Good For?"

Medical textbooks refer to the nervous system as the MASTER CONTROL SYSTEM of the body. The chart at left illustrates various parts of the body controlled by the brain through the spinal cord.

We all know arms, legs, fingers and toes receive their "Life" from the spinal cord, but DID YOU KNOW these other areas benefit from chiropractic care as well?

A misaligned spine pinches off vital nerves to the body and can lead to many health problems such as:

- ALLERGIES • ASTHMA • ARTHRITIC PAIN
- BACK PAIN • BURSITIS • CONSTIPATION
- COLITIS • DIABETES • DISC TROUBLES
- HAY FEVER • HEADACHES • NECK PAINS
- HEMORRHOIDS • LEG & KNEE PAINS
- NUMBNESS IN ARMS & LEGS • SCIATICA
- PAINFUL JOINTS • SHOULDER PAIN
- SINUS PROBLEMS • SKIN ERUPTIONS
- WHIPLASH

WE ARE OPEN 5 DAYS A WEEK

Mon.	9am—12 noon 3pm—8pm	Thurs.	Closed
Tues.	9am—1pm	Fri.	9am—12 noon 3pm—8pm
Wed.	9am—12 noon 3pm—8pm	Sat.	9am—1pm

Many patients have received permanent relief from the above symptoms through chiropractic care.

You owe it to yourself to find out if yours is a chiropractic case. Call now for an appointment. It could change your life.

FREE • FREE • FREE • FREE • FREE • FREE • FREE
ON YOUR FIRST OFFICE VISIT YOU WILL RECEIVE FREE

- SPINAL ADJUSTMENT
- SCOLIOSIS SCREENING
- POSTURE CHECK
- CONSULTATION

(ONLY CHARGE — X-RAYS)

Public Invited

Free question & information sessions are held on Wednesday evenings, 7 p.m. I urge you either to call now for an appointment, or arrange to attend one of our new patient orientations. Compare the Chiropractic approach for good health without the pills and potions of orthodox medicine.

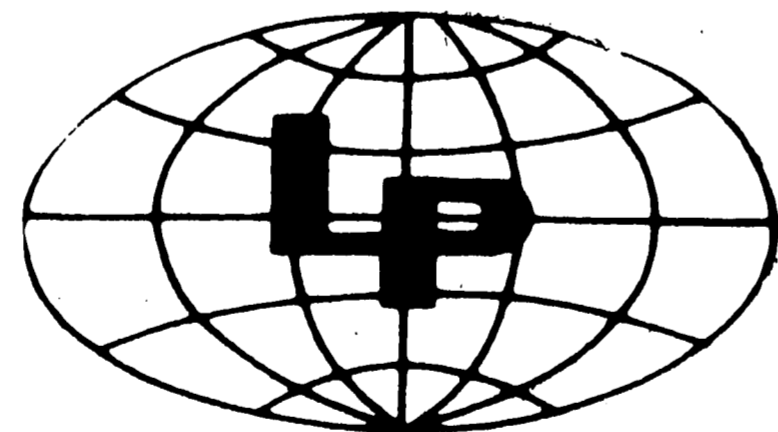

Call now for an appointment **348-7530**
 41616 W. Ten Mile Rd. (at Meadowbrook), Novi

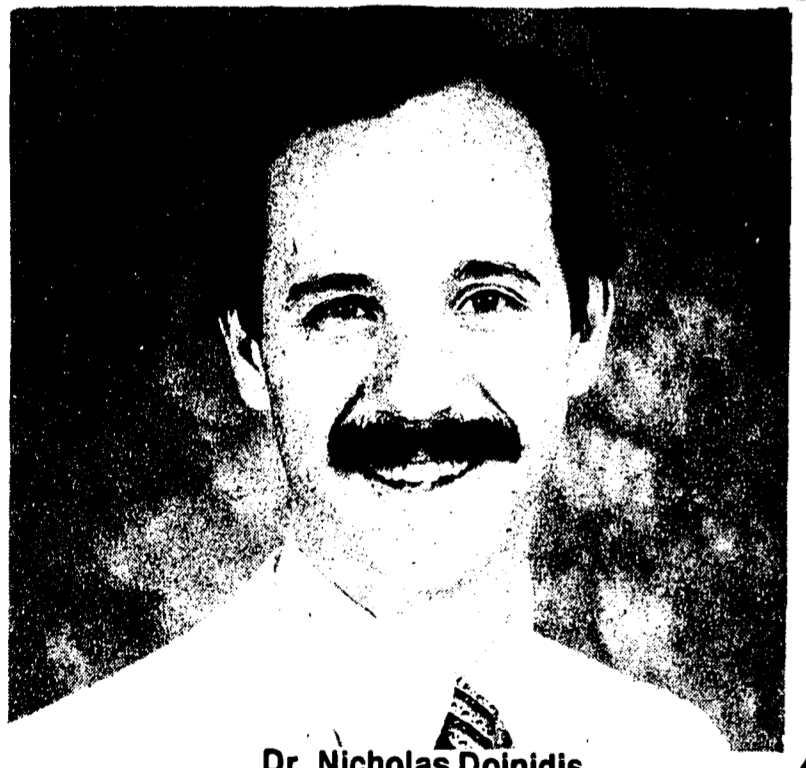

Dr. Nicholas Doinidis
Director

Doinidis

CHIROPRACTIC LIFE CENTER

"An Individual and Family Health Care Facility"

Modern Living

Helping out

Novi-Northville Fish says Thanksgiving food baskets get a big boost from Scouts

By KAREN RICE

It's easy to think of Thanksgiving as just one more chance to gobble up holiday treats and lounge in front of the television watching parades and football games. Others view Thanksgiving as an opportunity to get together with relatives in other cities and states.

For Kathy McGuffin of Novi-Northville Fish, dozens of Novi Cub Scouts and Boy Scouts, and eight needy families in this area, however, tomorrow will be a real day of thanks-giving: combined efforts by the Scouts and Fish volunteers contributed to the delivery of eight large loads of groceries to those families this week.

"You just don't realize how fortunate you are until you see some of these families," says McGuffin, who heads up the Novi contingent of Fish volunteers. "Some of them are really desperate."

Novi-Northville Fish is a community organization that helps provide temporary food supplies, clothing, child care, shelter and transportation when families in need of assistance call the Fish hotline for help. The organization also provides drivers for elderly and home-bound citizens who need help to make doctor appointments, and marshals volunteers to help with handyman tasks for those who can't do the work themselves.

Fish is a completely non-profit organization staffed by approximately 125 volunteers and it depends on donations and assistance from community service groups like the Jaycees, area churches and businessmen. The group has no fundraising projects.

Collecting supplies for Thanksgiving baskets, an annual project of Fish, received a big boost this year from Novi Scout troops thanks to the efforts of Jim Young, a Novi High School sophomore who is working toward his Eagle Scout ranking.

Part of the requirement for qualifying for the badge is developing a service project that will benefit the community, and Jim's decision to round up younger Novi Scouts for the holiday effort is credited by McGuffin as helping to complete the most successful food drive to date.

Jim approached leaders for Cub Pack 239, which includes five Cub dens and two Webelos dens, asking for their support of the project. He also brought members of his own Scout Troop 51 into the project. Jointly, the youngsters waged a door-to-door campaign asking for donations from community residents.

And the things they came back with, McGuffin says, will be unbelievably useful for the families who received the foodstuffs.

McGuffin delivers the supplies herself, along with another Fish volunteer. All



Jim Young (rear) watches younger Scouts (from left) Brent Van Dyke, Todd Kelsey, Scott Donaldson and David Mitchell sort food for Northville-Novi Fish baskets.

calls to Fish are kept strictly confidential, she says, as are food basket deliveries.

In some cases, dropping off such needed items is a thankless job, she admits. "There will be a couple of families who will be very upset when we show up," she says. "They don't want to accept charity. It's kind of difficult at times because it has to be handled very discreetly."

Despite occasional protests, however, Fish workers believe the work they do is needed. And McGuffin is convinced that outlying areas really need to start up their own Fish programs, too. She says the Novi-Northville chapter answers quite a few calls for help in Walled Lake and has received queries from South Lyon, although that is simply too far for the group to extend its boundaries.

Pure volume indicates Novi-Northville Fish is dealing with a very real presence of economically-troubled families; to date, Fish volunteers have answered more than 825 calls for help this year alone. Last year, they answered over 400 calls.

As Novi and Northville grow, so do the number of emergency calls, McGuffin explains. And the hard-hitting waves of inflation and unemployment have contributed to keeping Fish volunteers exceptionally busy.

McGuffin simply can't say enough about how fortunate Fish was to have had such help from the local Scouts. Partly, she's pleased because she believes that awareness of other people's difficulties should be instilled at an early age.

But McGuffin also appreciates the Scouts' work because she knows first-hand what good use the food will be put to.

"When I go to deliver the food," she says, "I usually take another member of Fish with me. And on the way back, there's always silence. We are just overwhelmed."

Individuals interested in joining Novi-Northville Fish are invited to write Fish, Box 56, Northville, 48167, or call Fish at 349-4350. The hotline number for needy persons is 455-2000.

Choralaires plan dual concert with Edison Glee Club



Director Janel Wassilak leads the Novi Choralaires

Good old-fashioned singing will be the star attraction of the Novi Choralaires holiday concert slated for 7:30 p.m. Saturday, December 6. Joining voices with the Choralaires will be members of the Detroit Edison Glee Club.

"Songs for All Seasons" will feature barbershop-type songs, Christmas carols and a medley of other vocal performances. Highlighting the program will be "Dueling Choruses," described as a take-off from the classic "Dueling Banjos."

"Dueling Choruses" was created by Janel Wassilak, director of the Choralaires, and the Glee Club head.

Together the two groups will perform "Summer Me, Winter Me," "Silent Night" and a medley from "Carousel." They also will sing individual numbers. The Choralaires will perform "Winkles, Blinken and Nod" among other songs, while the Glee Club will sing "I Don't Want to Walk Without You" as one of their solo selections.

Accompaniment will be provided by Stacey Becker, regular pianist for the Choralaires.

"Songs for All Seasons" is being sponsored by the Novi Jaycees and proceeds from the concert are earmarked for the National Institute for Burn Medicine in Ann Arbor.

Tickets for the concert will be available at the door and cost \$2 for adults and \$1 for children younger than 12.

According to Karen Tomilo, spokesman for the Choralaires, the directors of both choirs knew each other prior to the decision to host a joint concert and came up with the idea of singing together partly because the Choralaires were eager to put on more than one spring concert annually.

The Choralaires have about 35 singers who rehearse regularly at 7:30 p.m. Tuesdays at Novi Middle School South on Taft Road.

The Choralaires also perform for small groups in the area. Recently they sang at the Novi Community Art Fair sponsored by the parks and recreation department and performed for senior citizens at Northville First Presbyterian Church.

LEE'S CARPET SALE

SAVE UP TO **30%**



ANTRON III is designed to resist dirt so that carpets keep their new look for a long time. Plus, ANTRON III is tough, resilient, easy to maintain, and provides built-in protection against static shock.

ANTRON III—for what you really want and need in carpeting.

SALE ENDS SATURDAY, DECEMBER 6, 1980

NOVI FLOOR COVERING

41744 W. Ten Mile
NOVI-TEN PLAZA
348-2622

Village Needlepoint Shop

- Specializing in...
 - Needlepoint
 - Knitting
 - Crocheting
 - Traditional Rug Hooking
 - Quilting and Rug Braiding Classes
- 349-6685
150 Mary Alexander Ct. Northville

Put on a New Face!
Facials—Makeup
Haircut & Styling

Hair Sanctuary

Hair & Makeup Salon
Call the Scissors Wizard at
477-5231
34837 Grand River Farmington
one of the Beauty Shops
REDKEN

DeL's SHOES SLIPPERS

Great for Gifts!

Fluffies	
Children's Reg. \$5.00	\$375
Women's Reg. \$8.00	\$450
Sueded Leather	
Children's Reg. \$10.00	\$750
Women's Reg. \$13.00	\$975
Men's Reg. \$14.00	\$1050
Sueded Mocs	
Men's Reg. \$18.00	\$1350

133 E. MAIN-NORTHVILLE Mon. to 7 pm Thurs. 8:30 am to 7 pm 348-0852

322 S. MAIN-ROCHASTER Mon. to 7 pm Thurs. 8:30 am to 7 pm 452-8605

Metro Place Mall-WAYNE Mon. to 7 pm Thurs. 8:30 am to 7 pm 726-8600

131 E. LAKE-SOUTH LYON Mon. to 7 pm Thurs. 8:30 am to 7 pm 481-7412

Brighton Mall-BRIGHTON Daily to 7 pm, Sunday 12-5

Great Oaks Mall-ROCHESTER Men's Shop-Ladies & Children's Shop Thurs. 8:30 am to 7 pm 481-7412

Blood donors honored at recognition ceremony

Five Novi-Walled Lake area residents are among 50 special blood donors who were honored by the American Red Cross Blood Services at the fourth annual Pheresis Recognition Reception.

Local honorees were Leslie Cook, Sverre Jorgensen and Huguette Rainright of Novi and James Kennel and Jon Ferguson of Walled Lake.

Dr. A. William Schafer said the Red Cross considers pheresis donors as "special people" because they don't give whole blood. They give a specific component of their blood for a specific patient. They might give plasma, or platelets or white cells in a procedure that takes two or more hours.

In the pheresis procedure, said Dr.

Schafer, blood is drawn from one arm and passed through a blood separating instrument that separates and collects a single blood component. The remaining blood components, including the red cells, are returned to the donor usually through the other arm. The body normally replaces the component drawn in pheresis within 24 hours.

Pheresis therapy is used to treat patients undergoing cancer therapy or have leukemia or aplastic anemia or other diseases which respond to this type of medical therapy.

Pheresis donors range in age from 17 (with parental consent) to 65. Additional information about the pheresis program may be obtained from the Red Cross at 833-4440, extension 252.



Super spellers

Spelling bee winners evidently are always working on enlarging their vocabularies. Sometimes team research helps, too, as these Novi Middle School North students are discovering. The five youngsters, who topped spelling competition in Novi November 12, will participate in the regional bee in December at Muir Junior High School in Milford. Winners are Sandra Maloney (seated) and (standing, left to right) Kendi Papp, Steve Champagne, Amy Galland and Nicole Kidd. Mike Pali, who is not pictured, also took honors in the school spell-down. (Staff photo by John Galloway)

Local couple marries

Barbara Lauseng became the bride of David Fox in double-ring rites October 18 at Walled Lake United Methodist Church. The ceremony, performed by Reverend Lloyd Christler, was held in the church parlor and was attended by family members and a few friends.

Parents of the bride are Mr. and Mrs. Henry Kiersy of Loretto, Minnesota. The bridegroom is the son of Doris Ludwig of Rochester.

She wore a white linen dress with lace sleeves and pearl-embellished neckline. She carried a spray of white silk roses.

Assisting the bride as maid of honor was Sandi McKay. Bridesmaids were Denise Rose, Denise Fox and Sandy Fox. Diana Hankins was flower girl.

Best man was Mike Fox, white usher was Mike Rose, Gary Sandy and Don Smolinski.

The couple greeted 100 guests at Iraq Grotto in Pontiac before leaving on a honeymoon trip to Mackinac Island.

The newlyweds are residing in Novi.

Nails by Roberta
Get your nails in shape for the holidays

Coupon Savings

- *1⁰⁰ Off All Manicures \$4⁵⁰
- Liquid Wrap \$6⁰⁰
- Pedicures \$8⁰⁰
- *1⁰⁰ Off All Tissue Wrap \$16⁰⁰
- *\$10⁰⁰ Off Nail Extensions \$35⁰⁰

Valid through Dec. 13, 1980
by appointment only
10 west main st., northville phone 348-9747

Walled Lake names honor roll students

A total of 150 seventh graders from Walled Lake Junior High School have been named to the honor roll for the first marking period.

The list includes three seventh graders who earned perfect 4.0 grade point averages (GPAs) for the semester. Students who earned 4.0 GPAs are Lori Adair, Pamela Roselle and Stephanie Stricker.

Students on the list with GPAs of 3.83 are: Karen Byrka, Michael Elias, Lynn Galmeyer, Deborah Hageman, Mickey Hanner, Lena Hoffman, Laura Reynolds, Stephen Mensch, Cathy Moll, Sara Nimmo, David Okragly, Rebecca Olsen, David Powers, Andrew Rourke and Brian Thabaczka.

Named to the list with GPAs of 3.66 are: Paul Barshaw, Amy Berling, Deborah Brody, James Fassinger, Scott Gidley, Mark Hieber, Mark Holman, Carleen Klemczak, Susan L'Esperance, Amy Labowitch, Denise Larson, Gwen Mollanen, Lisa Rice, Katherine Starnes, Heather Stewart and Julie Stork.

Students named to the list with GPAs of 3.0 are: Charles Bartlett, Jerome Bourlier, Heather Brough, Larry Crum, Maria Dicarlo, Wendy Eastman, Thomas Elfrid, Victoria Hanton, Michelle Hrobosky, Angelina Keovis, Richard Lesnek, Gina Liddy, Erin McCormick, Matthew Metzger, Karen Peterson, Daryl Pritchard, Patrick Rofe, Jeffrey Sandeur, Michele Siemasz, Wendy Spender, Eric Suidam, Susan Tinker, William Williamson and Cynthia Wylie.

Nicole Schwanky was named to the honor roll with a 3.4 GPA.

Students cited for honors with GPAs of 3.33 are: Elizabeth Amati, Caryn Behrens, Thu Bui, Heather Croft, David Davis, Robert Dodd, Chad Doughty,

Robert Gould, Nicole Kekessy, Michelle Kosmatka, Jeffrey Mandlik, James Mirocha, Kelly Mitchell, Lee Mosen, Stacy Rae, Quentin Schanneil, Elizabeth Sirls, James Strong, Keith Vandersys and Brenda Whittemore. Stacy Burdick was named to the honor roll with a 3.20 GPA.

Named to the honor roll with GPAs of 3.16 are: Gerri Ackley, Dennis Atwell, Harriet Bacon, Diane Barthel, David Bartone, Laurie Bolam, Colleen Boyle, Kevin Breen, Stacy Brown, Christine D'Angelo, Deborah Erb, Matt Essenmacher, Michael Gabriele, Candy Gallyay, Michelle Graves, William Grisamer, Peggy Harris, Thomas Herremann, Jill Herrala, Marla Hughes, Nancy Hyde, Ondre Jacques, Deborah Jewell, Danielle Johnson, Mark Jurus, Michael Kane, Gretchen Kittle, Shannon Lang, Bridget Lantto, Donald Main, Russell Marshall, Timothy Marzulli, Jill Mensch, Brian Momborg, Kenneth Mussen, Daniel Nall, Kelli Parker, Heather Poehler, Veronka Pozdol, Barbara Salisz, Nicole Schulak, Michael Srock, Brian Walden and Adam Wurst.

Here's what's cooking

Here's what's cooking for lunch this week in the Novi elementary and middle schools:

Thursday and Friday, November 27-28: Thanksgiving vacation.

Monday, December 1: Hot dog on bun, 101 potato sticks (like McDonald's) and sliced peaches. Bonus: oatmeal raisin cookie.

Tuesday, December 2: Spaghetti with meat sauce, garlic bread and choice of relish tray, whole kernel corn or diced peppers. At middle schools: submarine sandwich and green beans.

Wednesday, December 3: Oven-baked chicken, mashed potatoes, cranberry sauce, apricots and hot biscuit with gravy. At middle schools: Hamburger on bun and carrots.

Thursday, December 4: Novi's homemade pizza, tossed salad with French dressing and fresh fruit. Bonus: lemonade. At middle schools: Hot dog on bun.

Friday, December 5: Fish square with tartar sauce, hot roll with butter and choice of tater tots, coleslaw or diced pineapple. Bonus: peanut butter brownie. At middle schools: chop suey and rice.

Children whose parents are unemployed, receive ADC payments, welfare benefits, or have experienced a temporary loss of income may be eligible to receive free or reduced-price lunches.

Decker PTO schedules swap and shop night

Now is the time to bundle together last year's skates, skis that have been outgrown and sleds the kids don't use anymore. Take them all to the third annual Swap and Shop, sponsored by the Decker Elementary School Parent-Teacher Organization.

Once there, trade them for new and different winter sporting goods or sell them and pocket the money for holiday spending.

Even better, the Swap and Shop isn't limited to equipment for winter sports nuts; snowmobile suits, gloves, warm coats and hats, and any winter clothing also can be brought in, according to a spokesman for the PTO.

Other features of the evening include a book and table games swap, craft tables, baked goods sales, cake walks and raffle ticket drawings.

The swapping session will be held next Monday (December 1) at 6:30 p.m. at Decker School, located at the corner of Decker Road and Pontiac Trail.

Items for the trade-off should be brought in as early as possible that evening. PTO members will be present to handle sales and help tag and price the articles.

The swap is a free service offered to community residents. The PTO will not extract surcharges on sporting goods, winter clothes or books. The organization will not accept responsibility for any stolen or damaged goods. Individuals are invited to stay with their equipment until it is sold or traded, or leave the works to PTO members. Items that have not been sold or traded and have not been reclaimed by their owners by the end of the evening will be donated to a charitable organization.

Individuals with children's books to trade or sell are asked to bring them in as early as possible. Paperback books that are donated to the PTO will be sold for 10 cents and hardbacks will cost 25 cents. Proceeds from the sale will be added to the PTO fund.

Any books not swapped by 7:45 p.m. will be up for sale.

As a bonus, Decker Wildcat pencils will be on sale; and at the price of seven for \$1, they make good stocking stuffers, the spokesman adds.

Individuals who would like to rent a table to sell crafts may do so by calling Ruth Rowen at 624-6975. Rental fee is \$3.

Maybe We're Not Magicians...

...but we do have some nifty little tricks for getting clothes spruced up. Takes experience like ours.

Freydl's
112 E. MAIN NORTHVILLE 349-0777

Christmas Giving

Freydl's
Beginning December 1—Open Evenings
11:30 p.m. 'til Christmas
USE OUR LAY AWAY

LADIES' & GIRLS'

- Evelyn Pearson and Katz, Fleece Robes—Gowns
- Pajamas—Dusters
- Lorraine Robes, Nylon and Tricot Slips

FAMOUS MAKER SELECTED SPORTSWEAR - 20% OFF

WHITE STAG
Ski Jackets - Pant Suits

PURSES HANDKERCHIEFS

- Gloves—Scarves
- Cranlin Knits and Drives Wash
- Koko Knits
- Shaker Square Socks & Ties
- Knits and Coordinates
- Catalina Sportswear

from \$5

COSTUME SCARVES

JEWELRY from \$1.29

SLACKS
by Glen Oaks
Ler and Tailor Bench
from \$20

SPORTS SHIRTS
by VanHousen,
Gordon Vee
from \$14.00

GIFT CERTIFICATES, TOO!

112 & 118 E. Main, Northville 349 0777

Wedding plans

A March 7 wedding date has been set for the marriage of Jacqueline Kovar of Redford and John L. Henrich of Novi. Parents of the couple are Mr. and Mrs. Russell J. Kovar and Mr. and Mrs. J. Donald Henrich, all of Novi.

The bride-elect, a 1979 graduate of Novi High School, is employed by Panasonic in Farmington. Her fiancé graduated from Novi High School in 1978 and is employed by Leaveway Corporation of Detroit.

CHILDREN'S HOME WALLED LAKE

ANNOUNCES AFTERNON NURSERY SCHOOL Starting Jan. 5, 1981

Enrollment Limited to 20 children
Ages 2½ to 6 624-7948

Creatively Yours

"ART FAIR OUTLET"
Will be open December 1
Just in time for Christmas Shopping

Strictly handcrafted items

- Quilts
- Pillows (needlepoint & quilted)
- Candelabras
- Stained glass
- Christmas Decorations
- Placemats, napkins & much more

322 E. Main St.-Northville
For information call 348-2519

RENE & MARGIE

Precision Hair Cutting
645 W. Seven Mile
Northville
348-3077

We use NEXUS Products

5 OFF any purchase of \$25 or more with this coupon.
All current fall & winter merchandise included. Coupon expires Sat., Nov. 29, 1980.

Start Your Christmas Savings Early... SPECIAL SAVINGS 2 Days Only
Fri., Nov. 28th & Sat., Nov. 29th

Fashion Shoes
Downtown Farmington Store Only

Rene & Margie invites you to help her celebrate her 3rd anniversary-with a 2 DAY ONLY SPECIAL!

10% OFF to all customers making an appointment for Dec. 2 or Dec. 3

Rene & Margie are an award winning team. Specializing in precision haircutting for men & women

New 1980-81 hair fashions for the holidays will help you celebrate in style!

Holiday Inflation Fighter Coupon

20% OFF
ANY OF OUR NATIONALLY NAMED MERCHANDISE with this ad

FRI. & SAT. NOV. 28th & 29th

TOWNE TOGGERY
DOWNTOWN FARMINGTON CENTER
OPEN MON. THURS. FRI. 10:00 a.m. - 7:00 p.m.
TUXEDO RENTALS FOR ALL OCCASIONS
VISA-MASTERCARD-DEBITERS CLUB

Start Your Christmas Savings Early...
SPECIAL SAVINGS 2 Days Only
Fri., Nov. 28th & Sat., Nov. 29th

\$5 OFF any purchase of \$25 or more with this coupon.
All current fall & winter merchandise included. Coupon expires Sat., Nov. 29, 1980.

Fashion Shoes
Downtown Farmington Store Only

SCOTT'S TOYS!

13.88
7.44
4.96
2.44
3.96
1.99
1.67

Beautifully styled dolls...
Baby's first bicycle...
Bicycle...
Doll & Stroller Set...
Doll & Stroller Set...
Big Man...
Save 31% FOR 2.99
While Toys Last! 20-30' 20 sheets per package. For last minute holiday wrapping.

13.99
15.96
4.96
1.67

\$5 OFF any purchase of \$25 or more with this coupon.
All current fall & winter merchandise included. Coupon expires Sat., Nov. 29, 1980.

Save 31% FOR 2.99
While Toys Last! 20-30' 20 sheets per package. For last minute holiday wrapping.

1.67
Three sheets for you free, 20' may open up.

WALLED LAKE SHOPPER

DOWNTOWN FARMINGTON CENTER

Joins us in the Heart of Farmington...

All our stores are jam packed with holiday gift ideas priced just right for every member of your family.

- Plenty of free parking
- Convenient Shopping Hours

Grand River & Farmington Roads

38 STORES FOR YOUR SHOPPING ENJOYMENT! PARK ONCE...

Community Ed sponsors Christmas cookie exchange

Novi Highlights By Jeanne Clarke 624-0173

Got your Christmas cookies made yet? Would you believe this year you only have to find one cookie recipe to end up with a terrific variety of treats?

Bring 12 dozen cookies to the Novi Community Education cookie exchange next Tuesday (December 2) at Middle School South, make a swap and go home with 12 dozen different types of cookies for easy holiday hosting. No peanut butter or chocolate chip cookies, please. Plus pick up some delicious recipes from other community residents.

Registration for the exchange is required but there is no fee for the trade. Call 349-1200 to sign up.

Community ed staffers are hard at work making up the winter class listings. Anyone who wants to share talents, craft abilities or time is invited to call Program Director Clara Porter to apply for a position as a community ed instructor.

RRUP SCOUTS: All leaders are reminded of the invitation from the Novi Jaycees to participate in the annual Christmas tree lighting to be held December 2 at city hall at 7 p.m. Each troop is asked to bring miniature bird feeders to be used as ornaments. The ornaments — pinecones smeared with peanut butter, for example — will be tied to the tree with red yarn.

Troops are also asked to bring three dozen cookies for the reception to be held afterwards in the Novi Library.

Girl Scout calendars and pocket planners are available for Christmas gifts by calling Debbie Barnes, 349-9393.

PERSONALS: Weekend guests at the home of Eugenie Choquet and Leon Dochot were Mr. and Mrs. Erwin Rhodes of Davison, who traveled to Wooden Shoe, Michigan, for some deer hunting and then to visit Leon Dochot while he was deer hunting in Beaver-ton.

Mr. and Mrs. Ed Callan and their eight-year-old granddaughter, Heather Allen, visited Mr. and Mrs. Roy Callan and their new son Clayton, in Indiana recently. While there, they watched a presentation of "Snoopy" directed by Terrie Callan.

Mabel Ash of Garfield Road has returned from Maryland where she attended the christening of her niece, Erica Ann Wildes, daughter of Mr. and Mrs. Gilman Wildes.

Former resident Douglas Caswell and his sons, David, Douglas Jr. and Robert, visited relatives in the area before going deer hunting in St. Helen, Michigan. The Caswells now live

PARKS AND REC: Tickets are available for the upcoming holiday concert featuring the Novi Chorales and Detroit Edison Glee Club at 7:30 p.m. December 6 at Novi High School.

The Chorales will grow from 35 to 70 singers and have been hard at work every Tuesday at Middle School South. Rehearsals this week will combine voices from the two chorales.

Tickets for the concert are \$2 for adults and \$1 for children under 12. Plan to attend for a pleasure-filled evening of family entertainment that's close to home.

Just a reminder that the Lions shuttle bus is available for all home games at the Pontiac Silverdome through the parks and rec department. The bus leaves city hall at 10:45 a.m. November

OLHSA: Senior citizens in the Novi area are invited to spend the holidays with friendly folks. The OLHSA center will be closed November 27-28.

The OLHSA staff can help seniors keep appointments at the medical clinic, which is available at the Novi Road center each Tuesday. Monthly blood pressure readings are also available.

REBEKAH LODGE: Independent Club will meet at noon Monday (December 1), at the home of Irene Wendland of Eleven Mile for the group's Christmas party and potluck luncheon. Members are asked to bring 25 exchange gifts in addition to games gifts. Past Novice Grands will meet for a party Christmas party December 18 at the home of Betty Harbin.

Walled Lake Central hosts Bloodmobile

Every 17 seconds, someone, somewhere needs a transfusion of blood and the Walled Lake Community Education Department is co-sponsoring a blood drive to fill the demands for blood.

A Red Cross Bloodmobile will be parked at Walled Lake Central High School next Monday (December 1) from 2 p.m. to 6 p.m.

Appointments can be made through the community ed office, 624-0202.

Donors should be between the ages of 18 and 66 (or 17 with parental permission), be in good health and weigh at least 110 pounds. A babysitting service will be provided from 2-5 p.m.

Community Notes

CHRISTMAS BAZAAR: The Novi Welcome Wagon will hold a Christmas bazaar with crafts, baked goods and wreaths of all kinds next weekend (December 6-7). The bazaar will be held in the Village Oaks clubhouse from 9 a.m. to 5 p.m. on Saturday and 10 a.m. to 10 p.m. on Sunday.

In addition, the bazaar will feature a food table where shoppers can purchase coffee, corn dogs and other treats.

Proceeds from the bazaar will be used to help finance community service projects. Members of the group are involved in helping handicapped individuals, senior citizens and residents of Whitehall Nursing Home.

HEALTH CLINICS: As part of a geriatric outreach program, Henry Ford Hospital is sponsoring medical examinations every Tuesday at the Novi Multi-Purpose Center.

Both Foster, administrative manager of the program, said the service is designed to provide comprehensive care in settings accessible to senior citizens. "We hope to provide an available health care service to help the elderly avoid acute illness and hospitalization whenever possible," she said.

A clinic will open soon at Walled Lake Villa Senior Citizens' Home on Pontiac Trail. Hours of the clinic will be 1:30-4:30 p.m. Tuesdays.

SENIOR CITIZENS: Hot lunches are served daily for senior citizens at the Richardson Community Center on Oakley Park Road in Commerce Township.

Lunches are served at noon by reservation only. Call 624-1266 to reserve a place at the drop-in center.

The center is open Monday through Friday from 9:30 a.m. to 2:30 p.m.

"THE NUTCRACKER": The Michigan Ballet Theatre will perform selections from "The Nutcracker" at Twelve Oaks Mall at 7 p.m. each Monday beginning December 8 in the mall's center court.

BAPTIST FILM: "The Miracle Goes On" will be screened at the First Baptist Church of Walled Lake this Sunday at 7 p.m.

The movie deals with the life of John Peterson, a composer of religious music. As a teenager, Peterson read a newspaper account of missionaries who were beheaded in China and decided to dedicate his life to works of the church through the talent of his music.

The film traces his life story from boyhood days in Kansas, a stint as a pilot in World War II and culminates in a massive concert of his own music played at Century II Auditorium in Wichita, Kansas.

NOVI LIBRARY: Two movies for youngsters will be shown at the Novi Library this Saturday. The 1 p.m. Saturday Special will feature "Mandy's Grandmother," the story of a girl who discovers that all grandmothers are not alike, and "Haley's Gift," about a magical experience between a girl and a mysterious stranger.

For more information on library programs, call 349-0720.

"HANSEL AND GRETEL": The Michigan Lyric Opera Company will present "Hansel and Gretel" this Sunday at 2:30 and 5 p.m. at the Marquis Theatre in Northville.

Based on the classic Grimm Brothers fairy tale, the musical was adapted by German composer Engelbert Humperdinck in 1888 and originally produced as a Christmas musical in Germany.

Tickets for "Hansel and Gretel" are available for \$3 each by calling 349-8110 during business hours or 349-0868 after 6 p.m. Tickets also can be

WIXOM LIBRARY: "Ricki Tikki Tavi," an animated film based on Rudyard Kipling's story of a confrontation between a mongoose and a cobra, will be screened at the Wixom Public Library this Saturday at 2 p.m. and next Tuesday at 4 p.m.

To register for the film presentations, call the Wixom Library, 624-8212.

CHILD CARE PROGRAM: The Living Lord Children's World Day Care Center, Inc., announces the sponsorship of the Child Care Food Program under Public Law 94-165.

The program is designed primarily to provide nutritious meals to all children enrolled in non-profit day care centers, outside school hours programs, and family day care homes.

EPHRAIM OF NORTHVILLE: 420-0877

UNITED PRESBYTERIAN CHURCH: 420-0877

ST. ANNE'S EPISCOPAL CHURCH: 349-3647

NOVI UNITED METHODIST CHURCH: 349-2692

FREEDOM LUTHERAN CHURCH: 349-2692

CHURCH HOLY CROSS EPISCOPAL: 478-3018

SWORD OF THE SPIRIT LUTHERAN: 478-3018

FIRST CHURCH OF CHRIST SCIENTIST: 478-3018

ROSS B. NORTHROP & SON
FUNERAL DIRECTORS
"70 Years of Funeral Service"

22401 Grand River Redford 531-0537
19091 Northville Rd. Northville 348-1233

Casterline Funeral Home, Inc.
Ray J. Casterline 1893-1959
Ray J. Casterline II
Fred A. Casterline
Phone 349-0611

SAVE 10%
...when you call us on Saturday.
One call places your Classified Ad in over 40,000 homes.

Monday-Friday 8:30 a.m. to 5 p.m.
Saturdays 8:30 a.m.-12 Noon
DEADLINE Monday 3:30 p.m.

Livingston County — 227-4437
South Lyon — 437-4133
Westland — 969-2121
Northville — 348-3022
Brighton — 227-4438
Novi — 348-3024

Don't wait too late!
if your NOVI NEWS is not delivered by 6 p.m.: Wednesday
Phone 349-3627

Visit our Christmas Shoppe
Have You Read Any Good Toilet Paper Lately?

Ap Unusual Holiday Gift \$3 per roll

Bon Ton Shoppe
FARMINGTON CENTER 35041 Grand River at Farmington Rd.
LIVONIA NEWBURGH PLAZA SIX Mile at Newburgh
RENAISSANCE CENTER Detroit
BRIGHTON MALL Grand River at I-96

the Terrace Shoppe, Inc.
Paris, Casual & Contemporary Furnishings
33021 Grand River Avenue, Farmington East of Farmington Rd./2 BLKS.
476-6550
Open Daily 10:00-5:00; Mon. & Fri. 10:00-9:00

HOLIDAY IDEAS IN RATTAN

Holiday Savings

SAVE \$10.11
\$29.88

SAVE \$7.11
\$19.88

SAVE \$4.11
\$12.88

SAVE \$3.11
\$9.88

America's #1 Self-Service Shoe Store. Payless ShoeSource

FARMINGTON 35041 Grand River Downtown Farmington Ctr. 476-2525

ROCHESTER 1160 S. Rochester Waunderfoot Mall 652-8191

KUT & DRY HAIR SALON
Custom Hair Designing Salons for Men, Women, and Children.
33181 Grand River Downtown Farmington Center 477-6091

Ask how you can get a FREE HAIRCUT!
Mon.-Fri. 9-6 * Sat. 9-4:30
Downtown Farmington Center 477-6091

FARMINGTON WISHING WELL

Famous for our hearty Homemade Soups & rich, unforgettable Desserts. Take a break from your holiday shopping and join us for a complete dinner or just a snack.

Breakfast Special \$4.99
Daily Specials \$2.99

Downtown Farmington Center 474-4848

THE VIDEO SYSTEM
THE BEST CHRISTMAS EVER... A MEMBERSHIP IN...

4 DAYS -- \$4.00
More Than 1,000 Titles To Choose From! "Speaking Lessons", "Star Wars", "Smiley and the Panda", "Pearly Lovers", All of Walt Disney's Classics

Full Membership -- \$350
or Rental \$12.00 per week
MARK SKLAR'S NEGATIVE OUTLOOK VIDEO

FARMINGTON DELI Party Trays

Trays include your selection of meats, cheeses, and bread.

Quality Trays at Unbeatable Prices
Supreme Bakery • Kowalski & Alexander
474-3800

38 Stores To Serve You...
1. Center East
2. C. Lark, Chgo. Park
3. C. Lark, Chgo. Park
4. Center East
5. Center East
6. Center East
7. Center East
8. Center East
9. Center East
10. Center East
11. Center East
12. Center East
13. Center East
14. Center East
15. Center East
16. Center East
17. Center East
18. Center East
19. Center East
20. Center East
21. Center East
22. Center East
23. Center East
24. Center East
25. Center East
26. Center East
27. Center East
28. Center East
29. Center East
30. Center East
31. Center East
32. Center East
33. Center East
34. Center East
35. Center East
36. Center East
37. Center East
38. Center East

ULTRA LOW TAR Cambridge

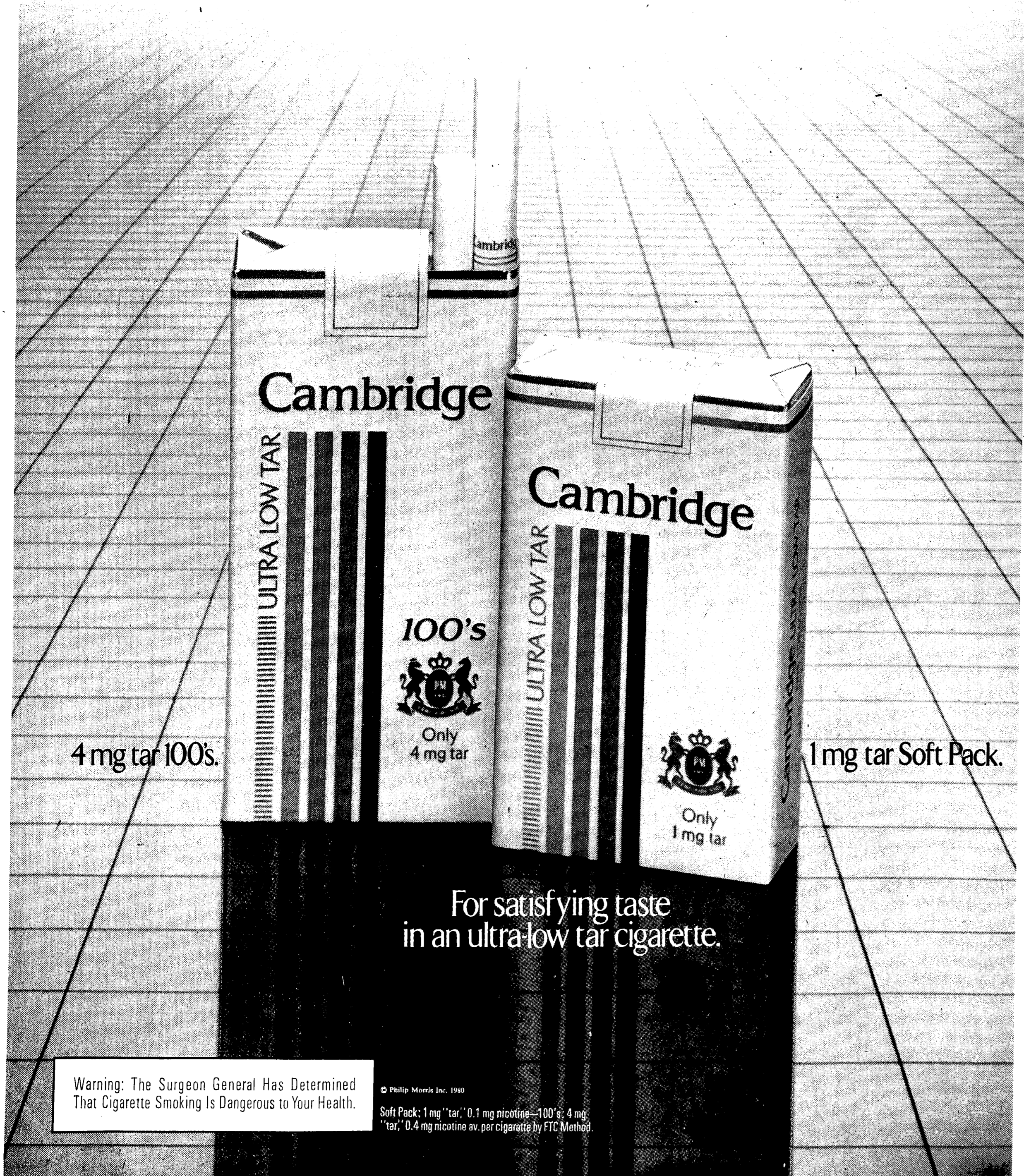

Warning: The Surgeon General Has Determined That Cigarette Smoking Is Dangerous to Your Health.

Soft Pack: 1 mg "tar," 0.1 mg nicotine—100's; 4 mg "tar," 0.4 mg nicotine av. per cigarette by FTC Method.

Section
C

GREEN SHEET

Slinger Home Newspapers

Want Ads
INSIDE

Wednesday, November 26, 1980

Chiropractors claim treatment is science

By PAUL MAGUIRE
"Science begets knowledge, opinion, ignorance."
Hippocrates
Or does it?
For Cornelius J. Farren, doctor of chiropractic whose practice is now located in South Lyon, there was some hard criticism of his choice to become a chiropractor back in 1956.
The criticism did not question his ability to practice as a qualified chiropractor, but rather the criticism was aimed at Farren's desire to become a chiropractor.
"Personally, many friends I grew up

with came to know me as a quack," Farren said. "Sometimes it hurt, when they said I was going to be a quack and rip off the people."
But Farren, now 38, looks back and knew that he made the right decision about his chiropractic profession. Currently, his practice is located in South Lyon, and he said he is keeping busy by treating 25-30 patients daily.
"They had no knowledge of what a chiropractor was at all," Farren said. But the above experience and sometimes critical view society takes on chiropractors had a negative effect on Farren for a time after he became a practicing chiropractor.
"When I first started," Farren said,

"I was very defensive and it usually hurt my ego and confused the patient." According to Dr. Timothy Terry, president of the Michigan Chiropractic Council, the experience Farren went through was not unusual for the times. Terry said the five years between 1965 and 1970 were some of the toughest years for chiropractors.
"They were called quacks, and labeled unprofessional and unethical," Terry said.
The profession of chiropractors was under fire especially from the American Medical Association (AMA). Terry said during that time, the AMA had a committee which existed to criticize the chiropractic profession.
"In the late 1960s it was a big political fight," Terry said. "The AMA had a committee, and that committee's sole purpose was to destroy the chiropractic profession."

But Terry said the move backfired for the AMA. Terry agreed there was a need to improve and upgrade the education of chiropractors, and criticism from the AMA helped to accelerate that process.
"The profession grew out of criticism from the AMA," Terry said. "And we are now a better professional standard at chiropractic colleges are higher, and better qualified instructors are being hired to teach."
Chiropractors, however, are not recognized or affiliated with the AMA. Dr. Marilyn Sauder, a medical doctor and general surgeon with a practice in South Lyon, said she does not see chiropractors in the same class as medical doctors.
"No, they should not be recognized," Sauder said. "I think chiropractors are in the same category as physical therapists."

Sauder said the vast majority of chiropractors have a skill, but she does not believe they have a science.
"They claim a knowledge that is not there," Sauder said. "But I do believe they have an art of relaxing muscles."
The central philosophy of chiropractic medicine deals with the central part of the human body, the spine.
According to the American Chiropractic Association (ACA), "Chiropractic is based on the premise that the relationship between structure and function in the human body is a significant health factor and that such relationship between the spinal column and nervous system is the most significant."
Farren said this is most important in his practice. Farren said chiropractors believe that malfunction of an organ or pain and stiffness in a joint or muscle is caused by an interruption of normal nerve impulses between the brain, spinal column and nervous system.
"As a chiropractor," Farren said, "I do what I can through manipulation to remove the interference."
According to Terry, the blocking of normal nerve impulses that can cause pain and body malfunction is called subluxations. More specifically,

subluxation is the mis-alignment of a vertebrae in the spinal column interfering with the normal nerve transmission.
The human spine has 33 bones called vertebrae. Soft disks between each vertebrae act as shock absorbers and allow for flexibility and movement. The spine also has more than 1,500 supporting muscles and ligaments and 31 pairs of nerves feeding to and from various parts of the body.
To rid the body of subluxations, adjustment and manipulation is used by chiropractors. Terry said an adjustment is moving a specific section of the spine to correct a subluxation. Manipulation is the overall movement of the total spine or any other bone or muscle.
Through these processes, chiropractors claim they can help eliminate pain, and more importantly, find the cause of the pain and try to reduce or eliminate it through adjustments and manipulation.
Leonard Westphal, 24, has been a patient of Farren's for the past 1½ months. Westphal works at the Michigan Seamless Tube Mill in South Lyon as a crane operator. For the past 12 years, Westphal said he has lived with a very painful back.
Westphal first visited regular medical doctors for treatment. But they never found the source of the pain or helped reduce the back pain.
Westphal said he has lived with a very painful back.
Westphal first visited regular medical doctors for treatment. But they never found the source of the pain or helped reduce the back pain.
Westphal said he has lived with a very painful back.
Westphal first visited regular medical doctors for treatment. But they never found the source of the pain or helped reduce the back pain.

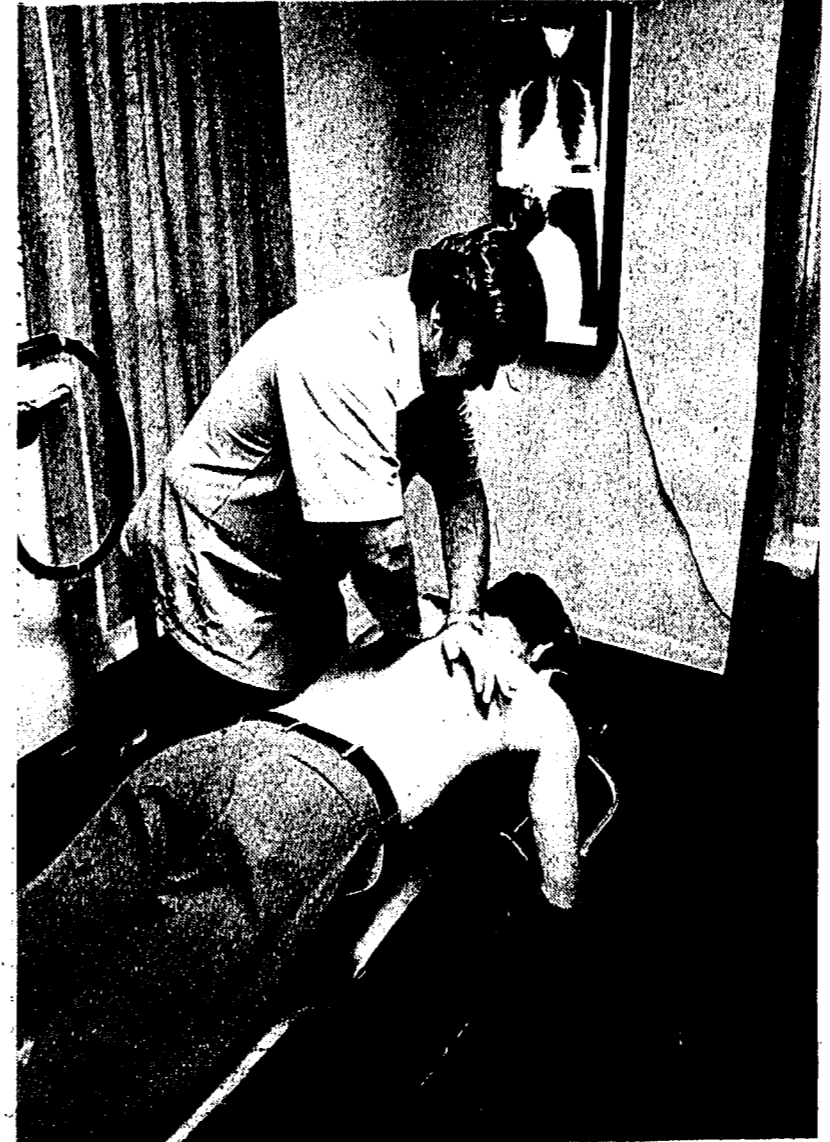

Westphal said he has lived with a very painful back.
Westphal first visited regular medical doctors for treatment. But they never found the source of the pain or helped reduce the back pain.
Westphal said he has lived with a very painful back.
Westphal first visited regular medical doctors for treatment. But they never found the source of the pain or helped reduce the back pain.
Westphal said he has lived with a very painful back.
Westphal first visited regular medical doctors for treatment. But they never found the source of the pain or helped reduce the back pain.

Westphal said he has lived with a very painful back.
Westphal first visited regular medical doctors for treatment. But they never found the source of the pain or helped reduce the back pain.
Westphal said he has lived with a very painful back.
Westphal first visited regular medical doctors for treatment. But they never found the source of the pain or helped reduce the back pain.
Westphal said he has lived with a very painful back.
Westphal first visited regular medical doctors for treatment. But they never found the source of the pain or helped reduce the back pain.

Westphal said he has lived with a very painful back.
Westphal first visited regular medical doctors for treatment. But they never found the source of the pain or helped reduce the back pain.
Westphal said he has lived with a very painful back.
Westphal first visited regular medical doctors for treatment. But they never found the source of the pain or helped reduce the back pain.
Westphal said he has lived with a very painful back.
Westphal first visited regular medical doctors for treatment. But they never found the source of the pain or helped reduce the back pain.

5 gallons of Kerosene FREE with purchase and this coupon
KEROSUN
The good news in home heating.
FOOTE GRAVELLY TRACTOR
West of Tall 348-3444 Mon.-Fri. 9-5
46401 Grand River-Novl Sat. 9-12

Kent readies for winter fun
Winter's fast approaching and bracing for it the people it inspires is Kensington Metropark near Milford.
One of the most popular winter playgrounds in southeastern Michigan, Kensington has facilities for ice skating, tobogganing, sledging, cross-country skiing and ski rental service, ice fishing, nature hikes and photography.
Once ice has formed general skating and hockey rinks, located on the lake in front of the boat rental building, will be open from 10 a.m. to 9 p.m.
The hilly slopes at the toboggan area are ideal for sledding and tobogganing, with five toboggan runs and a separate area for sledding.
Cross-country skiing is very popular at the park with 12 miles of trails for ice skating in advance. For covering all types of terrain radiating from the ski touring center.

NOVI TRANSMISSION
"CHRISTMAS SPECIAL"
TRANS. OVERHAUL (Most Cars) \$135.95 Plus Parts & Oil
SHOCKS (Most Cars) \$14.95 Plus Parts
BRING IN THIS AD FOR A DISCOUNT
EXHAUST SYSTEMS \$29.95 Plus Parts
COMPLETE BRAKE JOB \$29.95 Plus Parts
SAME DAY SERVICE
TUNE-UPS (4 & 6 cyl) \$12.95 Plus Parts (8 cyl) \$19.95 Plus Parts
ALL WORK GUARANTEED & DONE BY CERTIFIED MECHANICS
349-2305
44480 Grand River
Novl Between Novl & Tall Roads
Mon.-Fri. 8 am-11 pm

Park slates nature study
"Winter Ways" is the title of a Nature Walk to be conducted at the Nature Center of Kensington Metropark near Milford on Sunday, December 7 at 10 a.m.
Naturalist Steve Horn will discuss the affects of winter on plants and animals.
The program is "free" but persons should register in advance. For information/registration contact the nature center at 685-1561 (Milford).

INSULATE your PIPES!
PREVENT FREEZING IN BRIEF COLD SNAPS
use **WRAPON 40** FIBER GLASS INSULATION
35' ROLL
New Hudson Lumber Co.
5601 Grand River
New Hudson
437-1423

Discounts on all HOMELITE Chain Saws
Saw Chain Specials
12" 48L Reg. 12.49 Sale 9.95
14" 53L Reg. 13.76 Sale 10.95
16" 59L Reg. 16.28 Sale 11.95
20" 70L Reg. 19.22 Sale 13.95
24" 81L Reg. 22.33 Sale 16.95
LIMITED QUANTITIES
Bar & Chain Oil
HOMELITE \$3.50
Sale 12-14" 14-16"
Carry Cases Carry Cases
Reg. \$15.95 \$7.95 Reg. \$17.95 \$8.95
Files All Sizes Sale Reg. \$1.69 99¢ CASH & CARRY
NEW HUDSON POWER
53535 Grand River at Haas Rd.
437-1444

STERLING SILVER
Paying \$13 per ounce and up for complete sets
U.S. Silver Coins
Silver Dimes 1964 and Before \$1.00-\$1.30 ea.
Silver Quarters 1964 and Before \$2.50-\$3.25 ea.
Silver Halves 1964 and Before \$5.00-\$6.50 ea.
Half Dollars 1965 thru 1969 \$1.50-\$2.50 ea.
Silver war Nickels 1942-1945 \$0.50-\$0.65 ea.
SILVER DOLLARS \$1350
1935 and before
PRICES SUBJECT TO DAILY MARKET
WANTED POCKET WATCHES
STATE APPROVED SCALES

SHORTY'S Gold & Silver
8143 Grand River, Brighton
1/4 mile West of Brighton Mall
Across From Livingston Inn
MONDAY thru SATURDAY 10:00 to 5
FRIDAY 10:00-6:00 Phone 227-3787
PLENTY FREE PARKING

Discounts on all HOMELITE Chain Saws
Saw Chain Specials
12" 48L Reg. 12.49 Sale 9.95
14" 53L Reg. 13.76 Sale 10.95
16" 59L Reg. 16.28 Sale 11.95
20" 70L Reg. 19.22 Sale 13.95
24" 81L Reg. 22.33 Sale 16.95
LIMITED QUANTITIES
Bar & Chain Oil
HOMELITE \$3.50
Sale 12-14" 14-16"
Carry Cases Carry Cases
Reg. \$15.95 \$7.95 Reg. \$17.95 \$8.95
Files All Sizes Sale Reg. \$1.69 99¢ CASH & CARRY
NEW HUDSON POWER
53535 Grand River at Haas Rd.
437-1444

Last day of Sale Nov. 28th
18 hp Tractor
with 54" Blade
• 2 cylinder engine
• Exclusive hydraulic drive
• 2 speed rear axle
• Exclusive low clearance
• Hydraulic lift with down pressure
• Electric start and lights
• Tire size 8.00x16 rear 16-55x16 front
Reg. \$4325
SALE
\$3195 ALL 1981 MODELS Tractors
GRADE! LOAD! DIG! LEVEL!
Loaders
BACKFILL! SCRAPE! DRAG!
CLEAR SNOW! \$4150
NEW HUDSON POWER
53535 Grand River at Haas Rd.
2 miles west of Witom Road
Hours: Mon.-Fri. 9-6, Sat. 9-1
437-1444

GREEN SHEET CLASSIFIED ADVERTISING

One local call places a want ad in over 64,000 homes through the following newspapers:

Brighton Argus
313-227-4436

County Argus/Pinckney Post
313-227-4437

County Argus/Hartland Herald
313-227-4437

Fowlerville Review
517-548-2570

Livingston County Press
517-548-2570

Walled Lake News
313-689-2121

Novi News
313-348-3024

Northville Record
313-348-3022

South Lyon Herald
313-437-4133

Milford Times
313-685-8705

RATES
10 Words for \$3.80
20+ Per Word Over 10
Subtract .35 for repeat insertion of same ad

Classified Display
Contract Rates Available
Want ads may be placed until noon Monday, for that week's edition. Read your advertisement the first time it appears, and report any error immediately. Slugs for newspapers will not be accepted for errors in ads after the first or correct insertion.

ANIMALS

Animal Services 152
Farm Animals 152
Horses & Equip. 152
Household Pets 154
Pet Supplies 154

AUTOMOBILE

Automobiles 240
Auto Parts 220
Boats & Equip. 220
Compass, Trailers, 215
Equipment 215
Motorcycles 215
Trucks 230
Vans 235

EMPLOYMENT

Business & Professional Services 175
Business Opport. 185
Help Wanted 175
Situations Wanted 170

FOR RENT

Apartments 062
Business & Retail 070
Condominiums, 070
Townhouses 065
Dwelling 065
Industrial-Comm. 089
Mobile Homes 065
Mobile Homes Sites 067
Real Estate 065
Rentals to Share 058
Rooms 054
Trucks 054
Vacation Rentals 026

FOR SALE

Condominiums 022
Farms, Acreage 024
Houses 027
Land Property 026
Mobile Homes 023
Real Estate Wanted 026
Vacant Property 026

HOUSEHOLD

Antiques 101
Auto Wash 101
Bath 101
Farm Equipment 112
Farm Products 111
Furniture 101
Garage & Runways 103
Household Goods 104
Lawn & Garden Care & Equipment 109
Miscellaneous 107
Musical Instruments 108
Spraying Goods 108
Trade of Sew 114
Wanted to Buy 113

PERSONAL

Card of Thanks 013
Car Pools 012
Found 018
Free 018
Happy Ads 002
In Memoriam 014
Lost 018
Special Notices 010

ABSOLUTELY FREE

001 Absolutely Free
002 Absolutely Free
003 Absolutely Free
004 Absolutely Free
005 Absolutely Free
006 Absolutely Free
007 Absolutely Free
008 Absolutely Free
009 Absolutely Free
010 Absolutely Free
011 Absolutely Free
012 Absolutely Free
013 Absolutely Free
014 Absolutely Free
015 Absolutely Free
016 Absolutely Free
017 Absolutely Free
018 Absolutely Free
019 Absolutely Free
020 Absolutely Free

ABSOLUTELY FREE

021 Absolutely Free
022 Absolutely Free
023 Absolutely Free
024 Absolutely Free
025 Absolutely Free
026 Absolutely Free
027 Absolutely Free
028 Absolutely Free
029 Absolutely Free
030 Absolutely Free
031 Absolutely Free
032 Absolutely Free
033 Absolutely Free
034 Absolutely Free
035 Absolutely Free
036 Absolutely Free
037 Absolutely Free
038 Absolutely Free
039 Absolutely Free
040 Absolutely Free

Century 21
REAL ESTATE

Heritage Properties Co.
4335 Ten Mile 348-1300
Novi

Century 21
LINTENMUTH & HOLMES, INC.
(517) 223-3774

White REAL ESTATE
8066 W. Grand River 227-1546
Brighton

RYMAL SYMES REALTORS
Since 1923

Earl Keim REALTY
349-5600
330 N. Center - Northville

Nichols REALTY INC.
41074 N. Seven Mile Rd., Northville 348-3044

Century 21
QUALITY HOMES INC.

Earl Keim REALTY
349-5600

Nichols REALTY INC.
41074 N. Seven Mile Rd., Northville 348-3044

Earl Keim REALTY
349-5600

Nichols REALTY INC.
41074 N. Seven Mile Rd., Northville 348-3044

Earl Keim REALTY
349-5600

Nichols REALTY INC.
41074 N. Seven Mile Rd., Northville 348-3044

Earl Keim REALTY
349-5600

Nichols REALTY INC.
41074 N. Seven Mile Rd., Northville 348-3044

Earl Keim REALTY
349-5600

Nichols REALTY INC.
41074 N. Seven Mile Rd., Northville 348-3044

ABSOLUTELY FREE

041 Absolutely Free
042 Absolutely Free
043 Absolutely Free
044 Absolutely Free
045 Absolutely Free
046 Absolutely Free
047 Absolutely Free
048 Absolutely Free
049 Absolutely Free
050 Absolutely Free
051 Absolutely Free
052 Absolutely Free
053 Absolutely Free
054 Absolutely Free
055 Absolutely Free
056 Absolutely Free
057 Absolutely Free
058 Absolutely Free
059 Absolutely Free
060 Absolutely Free

ABSOLUTELY FREE

061 Absolutely Free
062 Absolutely Free
063 Absolutely Free
064 Absolutely Free
065 Absolutely Free
066 Absolutely Free
067 Absolutely Free
068 Absolutely Free
069 Absolutely Free
070 Absolutely Free
071 Absolutely Free
072 Absolutely Free
073 Absolutely Free
074 Absolutely Free
075 Absolutely Free
076 Absolutely Free
077 Absolutely Free
078 Absolutely Free
079 Absolutely Free
080 Absolutely Free

ABSOLUTELY FREE

081 Absolutely Free
082 Absolutely Free
083 Absolutely Free
084 Absolutely Free
085 Absolutely Free
086 Absolutely Free
087 Absolutely Free
088 Absolutely Free
089 Absolutely Free
090 Absolutely Free
091 Absolutely Free
092 Absolutely Free
093 Absolutely Free
094 Absolutely Free
095 Absolutely Free
096 Absolutely Free
097 Absolutely Free
098 Absolutely Free
099 Absolutely Free
100 Absolutely Free

ABSOLUTELY FREE

101 Absolutely Free
102 Absolutely Free
103 Absolutely Free
104 Absolutely Free
105 Absolutely Free
106 Absolutely Free
107 Absolutely Free
108 Absolutely Free
109 Absolutely Free
110 Absolutely Free
111 Absolutely Free
112 Absolutely Free
113 Absolutely Free
114 Absolutely Free
115 Absolutely Free
116 Absolutely Free
117 Absolutely Free
118 Absolutely Free
119 Absolutely Free
120 Absolutely Free

ABSOLUTELY FREE

121 Absolutely Free
122 Absolutely Free
123 Absolutely Free
124 Absolutely Free
125 Absolutely Free
126 Absolutely Free
127 Absolutely Free
128 Absolutely Free
129 Absolutely Free
130 Absolutely Free
131 Absolutely Free
132 Absolutely Free
133 Absolutely Free
134 Absolutely Free
135 Absolutely Free
136 Absolutely Free
137 Absolutely Free
138 Absolutely Free
139 Absolutely Free
140 Absolutely Free

ABSOLUTELY FREE

141 Absolutely Free
142 Absolutely Free
143 Absolutely Free
144 Absolutely Free
145 Absolutely Free
146 Absolutely Free
147 Absolutely Free
148 Absolutely Free
149 Absolutely Free
150 Absolutely Free
151 Absolutely Free
152 Absolutely Free
153 Absolutely Free
154 Absolutely Free
155 Absolutely Free
156 Absolutely Free
157 Absolutely Free
158 Absolutely Free
159 Absolutely Free
160 Absolutely Free

ABSOLUTELY FREE

161 Absolutely Free
162 Absolutely Free
163 Absolutely Free
164 Absolutely Free
165 Absolutely Free
166 Absolutely Free
167 Absolutely Free
168 Absolutely Free
169 Absolutely Free
170 Absolutely Free
171 Absolutely Free
172 Absolutely Free
173 Absolutely Free
174 Absolutely Free
175 Absolutely Free
176 Absolutely Free
177 Absolutely Free
178 Absolutely Free
179 Absolutely Free
180 Absolutely Free

ABSOLUTELY FREE

181 Absolutely Free
182 Absolutely Free
183 Absolutely Free
184 Absolutely Free
185 Absolutely Free
186 Absolutely Free
187 Absolutely Free
188 Absolutely Free
189 Absolutely Free
190 Absolutely Free
191 Absolutely Free
192 Absolutely Free
193 Absolutely Free
194 Absolutely Free
195 Absolutely Free
196 Absolutely Free
197 Absolutely Free
198 Absolutely Free
199 Absolutely Free
200 Absolutely Free

ABSOLUTELY FREE

201 Absolutely Free
202 Absolutely Free
203 Absolutely Free
204 Absolutely Free
205 Absolutely Free
206 Absolutely Free
207 Absolutely Free
208 Absolutely Free
209 Absolutely Free
210 Absolutely Free
211 Absolutely Free
212 Absolutely Free
213 Absolutely Free
214 Absolutely Free
215 Absolutely Free
216 Absolutely Free
217 Absolutely Free
218 Absolutely Free
219 Absolutely Free
220 Absolutely Free

ABSOLUTELY FREE

221 Absolutely Free
222 Absolutely Free
223 Absolutely Free
224 Absolutely Free
225 Absolutely Free
226 Absolutely Free
227 Absolutely Free
228 Absolutely Free
229 Absolutely Free
230 Absolutely Free
231 Absolutely Free
232 Absolutely Free
233 Absolutely Free
234 Absolutely Free
235 Absolutely Free
236 Absolutely Free
237 Absolutely Free
238 Absolutely Free
239 Absolutely Free
240 Absolutely Free

ABSOLUTELY FREE

241 Absolutely Free
242 Absolutely Free
243 Absolutely Free
244 Absolutely Free
245 Absolutely Free
246 Absolutely Free
247 Absolutely Free
248 Absolutely Free
249 Absolutely Free
250 Absolutely Free
251 Absolutely Free
252 Absolutely Free
253 Absolutely Free
254 Absolutely Free
255 Absolutely Free
256 Absolutely Free
257 Absolutely Free
258 Absolutely Free
259 Absolutely Free
260 Absolutely Free

ABSOLUTELY FREE

261 Absolutely Free
262 Absolutely Free
263 Absolutely Free
264 Absolutely Free
265 Absolutely Free
266 Absolutely Free
267 Absolutely Free
268 Absolutely Free
269 Absolutely Free
270 Absolutely Free
271 Absolutely Free
272 Absolutely Free
273 Absolutely Free
274 Absolutely Free
275 Absolutely Free
276 Absolutely Free
277 Absolutely Free
278 Absolutely Free
279 Absolutely Free
280 Absolutely Free

ABSOLUTELY FREE

281 Absolutely Free
282 Absolutely Free
283 Absolutely Free
284 Absolutely Free
285 Absolutely Free
286 Absolutely Free
287 Absolutely Free
288 Absolutely Free
289 Absolutely Free
290 Absolutely Free
291 Absolutely Free
292 Absolutely Free
293 Absolutely Free
294 Absolutely Free
295 Absolutely Free
296 Absolutely Free
297 Absolutely Free
298 Absolutely Free
299 Absolutely Free
300 Absolutely Free

ABSOLUTELY FREE

301 Absolutely Free
302 Absolutely Free
303 Absolutely Free
304 Absolutely Free
305 Absolutely Free
306 Absolutely Free
307 Absolutely Free
308 Absolutely Free
309 Absolutely Free
310 Absolutely Free
311 Absolutely Free
312 Absolutely Free
313 Absolutely Free
314 Absolutely Free
315 Absolutely Free
316 Absolutely Free
317 Absolutely Free
318 Absolutely Free
319 Absolutely Free
320 Absolutely Free

ABSOLUTELY FREE

321 Absolutely Free
322 Absolutely Free
323 Absolutely Free
324 Absolutely Free
325 Absolutely Free
326 Absolutely Free
327 Absolutely Free
328 Absolutely Free
329 Absolutely Free
330 Absolutely Free
331 Absolutely Free
332 Absolutely Free
333 Absolutely Free
334 Absolutely Free
335 Absolutely Free
336 Absolutely Free
337 Absolutely Free
338 Absolutely Free
339 Absolutely Free
340 Absolutely Free

ABSOLUTELY FREE

341 Absolutely Free
342 Absolutely Free
343 Absolutely Free
344 Absolutely Free
345 Absolutely Free
346 Absolutely Free
347 Absolutely Free
348 Absolutely Free
349 Absolutely Free
350 Absolutely Free
351 Absolutely Free
352 Absolutely Free
353 Absolutely Free
354 Absolutely Free
355 Absolutely Free
356 Absolutely Free
357 Absolutely Free
358 Absolutely Free
359 Absolutely Free
360 Absolutely Free

ABSOLUTELY FREE

361 Absolutely Free
362 Absolutely Free
363 Absolutely Free
364 Absolutely Free
365 Absolutely Free
366 Absolutely Free
367 Absolutely Free
368 Absolutely Free
369 Absolutely Free
370 Absolutely Free
371 Absolutely Free
372 Absolutely Free
373 Absolutely Free
374 Absolutely Free
375 Absolutely Free
376 Absolutely Free
377 Absolutely Free
378 Absolutely Free
379 Absolutely Free
380 Absolutely Free

ABSOLUTELY FREE

381 Absolutely Free
382 Absolutely Free
383 Absolutely Free
384 Absolutely Free
385 Absolutely Free
386 Absolutely Free
387 Absolutely Free
388 Absolutely Free
389 Absolutely Free
390 Absolutely Free
391 Absolutely Free
392 Absolutely Free
393 Absolutely Free
394 Absolutely Free
395 Absolutely Free
396 Absolutely Free
397 Absolutely Free
398 Absolutely Free
399 Absolutely Free
400 Absolutely Free

NOV/NORTHVILLE area, newly executive 4 bedroom, 2 1/2 bath, wood laminate floor, w/ fireplace, wall to wall carpeting throughout...

062 Apartments BRIGHTON, 2 one bedroom, 1 1/2 bath, full kitchen, full bath, full laundry, full storage...

062 Apartments WEST GATE VY NEW HUDSON area, spacious 2 bedroom apartment, full kitchen, full bath, full laundry...

062 Apartments WEBBERVILLE, like your own home, walk to downtown brick, sharp 1 bedroom, 1 1/2 bath, carpeted, appliances, parking...

063 Duplexes BRIGHTON, in town, two bedrooms, walk-out, three levels with full basement, full kitchen, full bath, full laundry...

065 Condominiums, Townhouses BRIGHTON, in town, two bedrooms, walk-out, three levels with full basement, full kitchen, full bath, full laundry...

069 Industrial-Commercial KING PLAZA SOUTH LYON, 16,800 sq. ft. center ready to lease, full kitchen, full bath, full laundry...

071 Office Space BRIGHTON, Downtown, perfect location, second floor, Call for information, (313)229-2900...

101 Antiques ANTIQUE, estate and moving items, hand selected, professional antique appraisal, Virginia Furniture, 1000 E. Grand River...

103 Garage/Rummage Sales BASE CO. #14 channel, RCA Co-Pilot, #14 static power, turner sky, 40" color TV...

104 Household Goods 2 Electric water heaters, \$50 each, or \$20 for each, (313)229-2900...

104 Household Goods NAUGHAYDE sofa, gold, excellent condition, automatic dial model, makes blind men, designs, buttonholes, etc...

105 Firewood FOR sale firewood by cord, \$35 each, Call, write or visit, you haul, Rebel Roy, Rod...

062 Apartments BRIGHTON, 2 one bedroom, 1 1/2 bath, full kitchen, full bath, full laundry, full storage...

062 Apartments WEST GATE VY NEW HUDSON area, spacious 2 bedroom apartment, full kitchen, full bath, full laundry...

062 Apartments WEBBERVILLE, like your own home, walk to downtown brick, sharp 1 bedroom, 1 1/2 bath, carpeted, appliances, parking...

063 Duplexes BRIGHTON, in town, two bedrooms, walk-out, three levels with full basement, full kitchen, full bath, full laundry...

065 Condominiums, Townhouses BRIGHTON, in town, two bedrooms, walk-out, three levels with full basement, full kitchen, full bath, full laundry...

069 Industrial-Commercial KING PLAZA SOUTH LYON, 16,800 sq. ft. center ready to lease, full kitchen, full bath, full laundry...

071 Office Space BRIGHTON, Downtown, perfect location, second floor, Call for information, (313)229-2900...

101 Antiques ANTIQUE, estate and moving items, hand selected, professional antique appraisal, Virginia Furniture, 1000 E. Grand River...

103 Garage/Rummage Sales BASE CO. #14 channel, RCA Co-Pilot, #14 static power, turner sky, 40" color TV...

104 Household Goods 2 Electric water heaters, \$50 each, or \$20 for each, (313)229-2900...

104 Household Goods NAUGHAYDE sofa, gold, excellent condition, automatic dial model, makes blind men, designs, buttonholes, etc...

105 Firewood FOR sale firewood by cord, \$35 each, Call, write or visit, you haul, Rebel Roy, Rod...

HOUSEHOLD SERVICE AND BUYERS DIRECTORY

ALUMINUM SIDING CUSTOM TRIM 15 Years experience, storm doors, gutters and roofing...

GENE'S APPLIANCE SERVICE Washers, Dryers, Dishwashers Pick-up service

PERM-X ASPHALT PAVING Resurfacing Repair Commercial, Residential

C & F CEMENT ALL TYPES OF CEMENT WORK GARAGES, DRIVES, WALKS, ETC.

PAVING & REMODELING BUILDING for 30 years, additions, remodeling, decks, siding, painting, etc.

EXCAVATING Top Soil, Roads, Sand and gravel delivered, Septic fields and sewers

CARPENTRY Work by best L.P. CARPET CLEANING Steam Method, Furniture Cleaning

Handyman Janitorial Services Painting & Decorating Piano Tuning Roofing & Siding Sewing Machine Repair Wallpapering Welding

Electrician Licensed, Residential, Commercial, Free estimates, Free estimates

Handyman Janitorial Services Painting & Decorating Piano Tuning Roofing & Siding Sewing Machine Repair Wallpapering Welding

Handyman Janitorial Services Painting & Decorating Piano Tuning Roofing & Siding Sewing Machine Repair Wallpapering Welding

Handyman Janitorial Services Painting & Decorating Piano Tuning Roofing & Siding Sewing Machine Repair Wallpapering Welding

Handyman Janitorial Services Painting & Decorating Piano Tuning Roofing & Siding Sewing Machine Repair Wallpapering Welding

LEE WHOLESALE SUPPLY 56965 Grand River, New Hudson, MI Phone 313-437-6044 or 437-6054

PAUL PROFIT CONSTRUCTION COMPANY REMODELING AND ADDITIONS GARAGES AND ALUMINUM SIDING

HORNET CONCRETE CO. READY MIX CONCRETE DRIVEWAYS, PATIOS, WALKS, ETC.

HAMILTON Custom Remodeling, Additions, Decks, Siding, Painting, etc.

FOR LUMBER HARDWARE, PAINT and complete line of MATERIALS—its NEW HUDSON LUMBER

CHUCK THE CARPENTER-3181 CARPENTER, licensed, will rough, finish, trim, etc.

Handyman Janitorial Services Painting & Decorating Piano Tuning Roofing & Siding Sewing Machine Repair Wallpapering Welding

Handyman Janitorial Services Painting & Decorating Piano Tuning Roofing & Siding Sewing Machine Repair Wallpapering Welding

Handyman Janitorial Services Painting & Decorating Piano Tuning Roofing & Siding Sewing Machine Repair Wallpapering Welding

Handyman Janitorial Services Painting & Decorating Piano Tuning Roofing & Siding Sewing Machine Repair Wallpapering Welding

Handyman Janitorial Services Painting & Decorating Piano Tuning Roofing & Siding Sewing Machine Repair Wallpapering Welding

Handyman Janitorial Services Painting & Decorating Piano Tuning Roofing & Siding Sewing Machine Repair Wallpapering Welding

Handyman Janitorial Services Painting & Decorating Piano Tuning Roofing & Siding Sewing Machine Repair Wallpapering Welding

Vikings grapple with rebuilding

Boy, does Randy Hyde know what it's like to fight an uphill battle.

After three years of coaching the Walled Lake Central wrestling team — and watching the Vikings win just once in each of the past two seasons — Hyde is infinitely familiar with the term "rebuilding." But that's pretty much the outlook again this winter, he says.

"We just didn't get many people to come out last year," Hyde notes, "and it looks pretty much the same this year. I was expecting a much better turnout."

"What can I say? I'm pretty depressed about it."

The Viking grapplers aren't only undermanned, they're underclassed. As of late last week, only 15-20 students had come out for the squad. Among that bunch are just two senior and three junior returnees who will figure prominently in the club's 1980-81 plans.

Leading the seniors will be Steve Allen, a winner in 20 matches last year.

Though Hyde says he's still not positive who'll line up in which weight class, he's presently got Allen pegged at the 132-pound slot.

Joining Allen will be Barney Kelley, a strong but untested battler who's currently slated to fill the 138-pound class. Kelley suffered a broken foot last year, resulting in his missing the entire season.

Moving down to the juniors, Scott Cartwright, Rob Pytel and Ed Brinker will try to boost the Vikes in the middle weights. Cartwright's tentatively slated for duty in the 126-pound category, while Pytel and Brinker currently look to see action at 132 and 145 respectively.

The sophomores consist of four varsity holdovers from last winter. John Andrews (105) and Brian Golin (112) are on one end of the scale while Tim Ginster (155) and Mike Arnold (167) occupy the other end.

Ginster and Arnold, unfortunately, are exceptions on the team — that is, the club has historically had difficulties filling out the heavier weight categories. Hyde explains that many students who would be ideal choices to fill these spots usually play football.

"The upper weight people who play football certainly are familiar with working out," the young pilot states. "But I don't think they want to put in the extra work that you've got to do in wrestling."

"It's just a matter of too much work and too much time for the kids to want to take."

With that in mind, it seems that Central's wrestling coach can only hope that one or two things happen this year, and soon: 1) that one or more surprise grapplers will emerge; and/or 2) that more come out for the team as the season progresses. But Hyde's realistic enough to admit that the chances of either of those hopes panning out are dim.

Central's ultimate real hope, Hyde says, lies within the still-developing bodies of prospective future wrestlers.



Rob Pytel (top) and Ed Brinker will vie for middle weight slots

Improvement a key for Wildcat cagers

Ron Flutur is refreshingly realistic when it comes to assessing his 1980-81 Novi basketball team.

"Well, we were 3-17 last year," says the man who's starting his ninth year at the Wildcat helm, "and we lost our top rebounder (6-8 center Craig Iseli) and top scorer (Jeff Clark) to graduation. I think that's got to show that this will be a rebuilding year."

Flutur is well aware of the fact that that very word often is connected with losing. But he's not sure that that's necessarily the case with this bunch.

"I've seen definite progress already," the easy-going pilot states. "A couple of weeks ago we looked like we were in real trouble, but I'm feeling better about the team these days. We're going to take some lumps, but I think we'll improve as we go along."

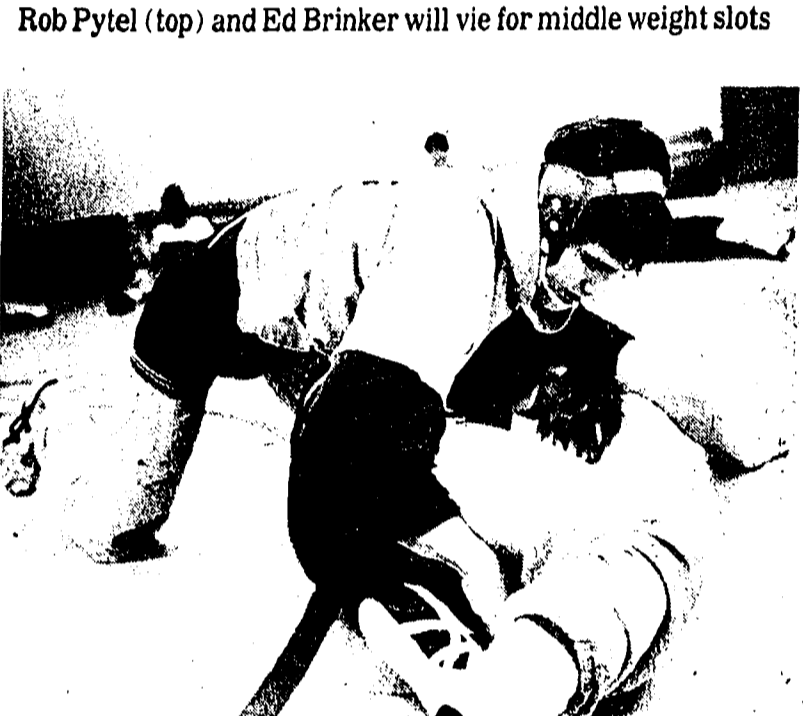

Central ace Steve Allen (top) and Mike Brown are two keys

UNO
International Games, Inc.
Presenting
THE WORLD'S LARGEST INDOOR MIDGET AUTO RACE
PONTIAC SILVERDOME
"Heroes vs Outlaws"

- Johnny Parsons, Jr.
- Pancho Carter
- Bill Vukovich
- Spike Gehlhausen
- Rick Ferkel
- Steve Kinser
- Sammy Swindell
- Doug Wolfgang

80 cars racing on a 1/4 mile indoor dirt track

Saturday, December 6, 1980

Heat Races 1:00 pm
Adults—only \$3.00
Children (12 & under)—only \$1.00

Featured Races 8:00 pm
Adults—only \$8.00
Children (12 & under)—only \$1.00

Tickets available
Pontiac Silverdome, 1200 Featherstone, Pontiac, Michigan 48057
and ALL TICKET OUTLETS
For additional information, call (313) 352-0155

Wheel Horse PRESENTS

THE GREAT STAMPEDE

SAVE \$500
B-165 LAWN TRACTOR
With 37" Blower
\$1645

SAVE \$700
C-105 GARDEN TRACTOR
With 42" Blower
\$2290

- 16 hp Twin Briggs
- 8 speed transmission
- Mows, Tills, moves snow
- 10 hp Kohler Cast Iron
- 8 speed transaxle
- Tach-a-matic Hitch

BOB'S HARLEY DAVIDSON
645 E. Grand River
Brighton

D & K LAWN & GARDEN
6438 Canton Center Rd.
Canton

THE MOWER SHOP
32480 Northwestern Hwy
Farmington Hills

HARVEY'S
7286 East M-36
Hamburg

HIGHLAND OUTDOOR CENTER
1135 Milford Road
Highland

RAY LAWN & GARDEN
3645 S. Gratiot
Mt. Clemens

MARK'S SMALL ENGINE
1029 Northville Road
Northville

HARP'S SALES & SERVICE
1980 S. Lapeer Road
Oxford

KING BROTHERS
2091 Pontiac Road
Pontiac

LEE'S LAWN & GARDEN
145 University Drive
Pontiac

ST. CLAIR-MACOMB CO-OP
6827 Gratiot
Richmond

MILATE LAWN & LEISURE
13244 Huron River Drive
Romulus

WEINMARTZ SUPPLY
4651 VanDyke
Utica

F & R TRACTOR
3137 VanDyke
Warren

WATERFORD FUEL & SUPPLY
3943 Airport Road
Waterford

855-1075

Is Our Business

855-1075

WWW WWW WWW

To have The News home delivered, call 349-3627

WINTER WALDEN SKI CLUB
Teaching Kids to **SKI**
Saturday & Sunday
Is Our Business
855-1075

WWW WWW WWW

To have The News home delivered, call 349-3627

HOUSE OF DENTURES
Licensed Dentist
26350 Grand River
Farmington Hills
2 1/2 Blocks West of I-75
at I-275

FREE Consultation and Exam
• Refines & Repairs Same Day
• Quality, Personalized Service
• Partial

Insurance Accepted For Appointment Call 478-1495

CAN THE WOMAN WHO PICKS OUT YOUR TIES BE TRUSTED TO PICK OUT YOUR CHAIN SAW?

Picking out a tie or a shirt is one thing. But when someone picks out a chain saw for you, they better know exactly what to look for.

Like the quality and precision that go into a Stihl® the world's largest selling chain saw. Get a Stihl under the tree!

"Bonus Special" receive over \$45 worth of accessories.

With the purchase of any Stihl® 010 or 015 "Bonus Special," you receive over \$45 worth of accessories at participating Stihl dealers. Offer includes matching carrying case, spare cutting chain, bar groove cleaning tool, file and handle, wedge, 8 oz. can of engine oil, wrench, owner's manual, and handy booklet about cutting firewood.

Standard equipment with all Stihl saws.

Visit a Stihl® Dealer near you:

- BRIGHTON**
THESEER OUTDOOR PRODUCTS
9160 W. Grand River
225-6562
- CANTON**
PLYMOUTH CONSTRUCTION EQUIP.
41899 Ford Rd.
981-0240
- LIVONIA**
COMMERCIAL LAWNMOWER
34855 Plymouth Rd.
345-9880
- PLYMOUTH**
SAITONS GARDEN CENTER
587 W. Ann Arbor Trail
453-7220
- TOM'S HARDWARE**
905 Orchard Lake Rd.
1960 Upperville Rd.
558 S. Lapeer Rd. (Oakard)
- S. LYON**
McFARLAND SHARPENING
8860 Pontiac Trail
437-1341
- WALLED LAKE**
WEAVER'S SAW SHOP
1980 E. West Maple Rd.
624-5648
- PONTIAC**
LEE LAWN & GARDEN
945 University
373-7220
- NOVI**
GARDNER INC.
4183 Grand River
348-3353

STIHL
The World's Largest Selling Chain Saw

Deep Warriors remind McBride of former glory days

Carl McBride has seen this kind of Walled Lake Western wrestling team before.

"This bunch looks as good as the 1973-74 team," the veteran mat mentor says. "We have depth, experience and leadership."

Incidentally, that 73-74 club finished with a 15-1 record.

McBride's optimism is understandable. Seven of his 50-plus varsity hopefuls are seniors, nine more are juniors and the underclassmen show plenty of promise.

Leading this winter's crop, of course, is team captain Angelo Buttazzoni. A participant in the 167-pound weight class this season, he finished fifth in the state at the Class A level a year ago and posted a 39-5 overall record.

Buttazzoni will be flanked by three senior alternate captains for the 1980-81 campaign, and a fine-looking trio it is. Eddie Miu, the author of a 29-1 record a year ago, returns to anchor the 98-pound position. He'll face competition from sophomores Ralph Henriksson and John Desjardins.

Another alternate captain is Carlo Castiglione, a 165-pound battler who'll mix it up in the 165-pound class. His prime competition figure is junior Joe Bauer.

The remaining alternate captain is 126-pounder Nick Giagola, who like Castiglione finished with an 11-16 record last winter.

Other seniors who hope to contribute to this edition of the Warrior grapplers are Lance Lemon at the 112-pound level; Scott Pitcher at 132; and Don Moss, an untested hopeful at the 145 pound slot. Moss will vie with sophomore Aldo Buttazzoni (10-15 in 79-80).

The juniors don't look too shabby, either. They're led by 105-pounder Larry Krass, the holder of a 38-2 record last year. Sophomore Tim Evans will compete with him for a spot.

Meanwhile, at 112, junior Dennis Wiedenbeck is one of three grapplers pushing for a starting nod. His competition is the aforementioned Lemon and sophomore Dave Millitello.

At 119, junior Neil Fenzel will try to make the jump from the 105 class he occupied last winter. A 24-10 finisher last year, he'll be pressed by sophomores Rob Westcott and Tim Bosynski.

Among the other juniors not previously mentioned is Eddie Smith, who'll battle Scott Pitcher for 132-pound honors. Another junior hopeful is Waterford transfer Craig McCallum, a prime candidate for the 155-pound job.

Two important positions that McBride hopes can be filled by juniors are the two highest weight classes. McBride says that Rich Richardson (9-11) will duke it out with fellow juniors Bud Westcott and Jim Liggett at 198. The two who aren't chosen for that position will vie at the heavyweight slot.

The only weight class not yet mentioned (138) seemingly belongs to Frank Hadish right now. The sophomore comes over from neighboring Walled Lake Central.

McBride also has good reason to be optimistic about the future with such freshmen as Bruce Giddings, Matt King, Matt Turner, Ken Tank, Steve McBride, Gino Rea, Bobby Rich and Rod Shev.

Looking at this year, the Western coach says "we have a well-balanced team. We've got a lot of people at all of the spots except 145 and heavyweight."

"It's still early, but we're starting to come around. The ranking matches that we hold (the club was slated to do

Grapplers eye mat title



Eddie Miu (top) and Nick Giagola help lead Western

Fall INSULATION SPECIAL

\$335 per 1,000 sq. ft. ceiling 6" blown fiberglass FREE ESTIMATES

Roll insulation for Do-It-Yourselfers
JONES INSULATION SUPPLIES
26111 LANNY'S • NOVI • 348-9880

Detroit Red Wings

Thurs., Dec. 4 vs Quebec 7:30 p.m.
Sat., Dec. 6 vs Philadelphia 1:30 p.m.

Tickets at Joe Louis Arena, and all CTC Outlets including: Hudson's, Kay Baum's, Olympia Ticket Service, Fisher Theatre, Windsor Arena, B. B. B. Bookstore, Connolly's Jewelers, Shapers, Showerman's Party Store, Dickers Den

TICKET INFORMATION (And Group Sales)
962-2000

BANKING
24 HOURS A DAY — 7 DAYS A WEEK

METRO BANK anytime teller

NOV. AT FARMINGTON AND FARMINGTON HILL AND AT
32 CONVENIENT LOCATIONS THROUGHOUT MICHIGAN
APPLY FOR YOUR ACCESS CARD NOW

METROPOLITAN NATIONAL BANK OF FARMINGTON

FARMINGTON'S ONLY COMMUNITY BANK
Locally owned-Locally Managed-Locally Staffed

Farmington Hills Office 27500 Farmington Road Telephone 553-4200 Farmington Office 33205 Grand River

AN EQUAL OPPORTUNITY LENDER MEMBER - FEDERAL DEPOSIT INSURANCE CORPORATION

INVENTORY CLOSE-OUT SAVE NOW—EXCELLENT BIRTHDAY & CHRISTMAS GIFTS!

Indoor/Outdoor Precision Skates

• All sizes available
• 1,000 pairs while they last
• Retail price \$54

\$3.95

Indoor/Outdoor Sims Precision Wheels
2,000 Sets While They Last
Special Close-out Price **\$18.95** Retail \$31.95

First Flight Vinyl Shoe Skate

With urethane wheels, unground precision bearings & double action.

Children Mens & Ladies **\$39.95**

Pacer Precision Outfits Mens & Ladies **\$79.95**

BONAVENTURE SKATING CENTER
24505 Halstead Rd. (1 blk. N. of Grand River)
Farmington Hills 476-2200

EXTRA BONUS
ONE FREE ADMISSION PASS TO OUR WEEKDAY SESSION FOR EVERY CHAIRS PURCHASED FROM OUR PRO SHOP.

Farmer John's Greenhouse

Christmas Poinsettias
4" 2" (25 or more 12")
6 1/2" 1 1/2" (25 or more 13")
6 1/2" 2 Stem 1 1/2" (12 or more 18")
7 1/2" 3 Stem 1 1/4" (12 or more 18")
10" 5 Stem 1 1/2" (12 or more 20")

Hanging Baskets from \$2.00 All Sizes Available

Douglas Fir Christmas Trees
We have the LARGEST and NICEST selection in the great Over 1,000 to select from: 4 feet to 15 feet

Complete line of SCOTCH PINE and SPRUCE Christmas trees, also. Fresh Cut Flowers Holiday Wreaths and Roping 8' - 30' Sweetheart Roses \$11.95 doz.

FARMER JOHN'S GREENHOUSE
26950 HAGGERTY ROAD
1/2 Mile South of 12 Mile
553-7141

Merit Scores Decisive Victory!

Significant majority rates MERIT taste equal to - or better than - leading high tars.

There's a low tar cigarette that's challenging high tar smoking—and winning.

The cigarette: MERIT.

High Tars Finish Second

Latest research proves smokers prefer MERIT.

Blind Taste Tests: In tests where brand identity was concealed, a significant majority of smokers rated the taste of low tar MERIT equal to—or better than—leading high tar brands. Even cigarettes having twice the tar!

Smoker Preference: Among the 95% of smokers stating a

preference, the MERIT low tar/good taste combination was favored 3 to 1 over high tar leaders when tar levels were revealed!

Long-Term Satisfaction: In the latest survey of former high tar smokers who have switched to MERIT, 9 out of 10 reported they continue to enjoy smoking, are glad they switched, and report MERIT is the best-tasting low tar they've ever tried!

MERIT is the proven alternative to high tar smoking. And you can taste it.

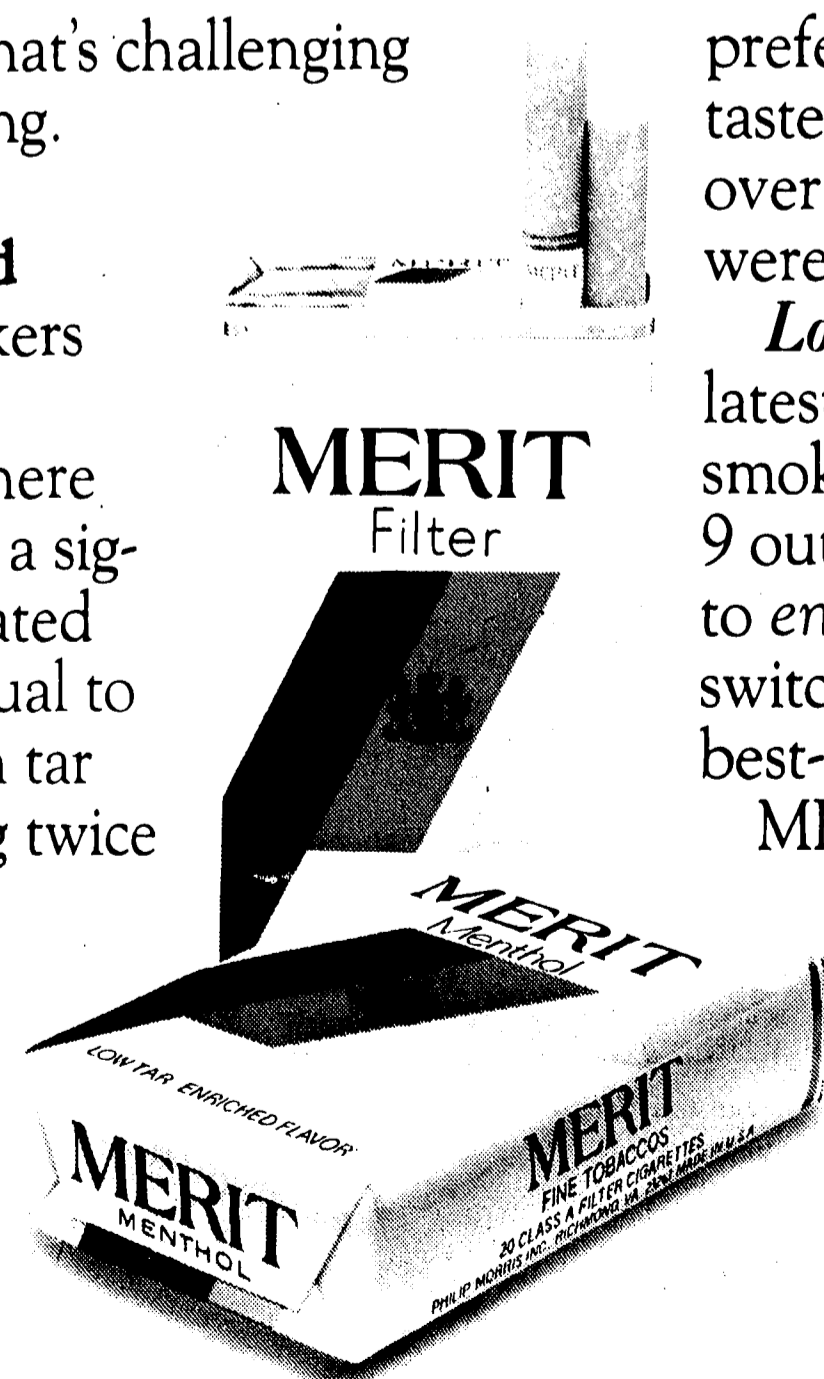

MERIT

Kings & 100's

Philip Morris Inc. 1980
Kings: 8 mg "tar," 0.6 mg nicotine—100's Reg: 10 mg "tar," 0.7 mg nicotine—100's Men: 11 mg "tar," 0.8 mg nicotine av. per cigarette, FTC Report Dec. 79

Warning: The Surgeon General Has Determined That Cigarette Smoking Is Dangerous to Your Health.



Central's Ken Butler planned some surprises for Brighton

Sport Shorts

Walled Lake's Community Education Department will sponsor a women's basketball program this winter.

Any woman 18 years or older interested in participating in the 10-week program should attend an organizational meeting at Walled Lake Junior High School on Sunday, December 7, at 4:30 p.m. The meeting will last 15 minutes and be followed by open gym. Interested individuals or teams should come dressed to participate.

Registration fee is \$10 per person. Further information is available from Sue Stulgross at 624-0202.

Novi's Parks and Recreation Department reminds all sixth, seventh and eighth graders in Novi that an open gym will be held every Wednesday evening at the Middle School South gymnasium from 8:30-10 p.m. Cost is 50 cents per night at the door.

Anyone looking for a good deal on Detroit Pistons' basketball games can look no further than the Novi Parks and

Rec department. The department is offering discounts on five selected home games this season, offering \$4.50 tickets instead of the normal \$7 fare.

The special rates apply to the following games: December 12 versus Cleveland; January 20 versus Philadelphia; February 21 versus Boston; and March 20 versus Milwaukee. Tickets may be purchased 20 days before each contest.

Despite all of this talk about basketball, the Detroit Lions' football season is still very much in full swing. The Novi Parks and Rec department reminds all Lions' fans that it offers a shuttle bus service on each Detroit home date. The bus leaves from Novi City Hall.

For further information about any Novi Parks and Rec program, call 349-1976. Additional information about Walled Lake Community Education Department programs is available at 624-0202.

Sportalk

By REID CREAGER



Viking cagers have their work cut out against Brighton

Walled Lake Central's girls' basketball team knew exactly what it was running into when it took on Brighton last night (Tuesday) in the Class A District 23 final game—a Bulldog buzzsaw.

Brighton is back, complete with a rejuvenated Peggy Harte. The Bulldogs chewed up and spit out Howell in their tune-up for Central as Harte—who had missed a big chunk of the season with ankle problems—poured in 32 points.

Viking Coach Ken Butler is aware of that, and he knows his team must cool down last year's all-stater if Central is to claim its third district title in the last four years.

"She's the key," said the longtime Viking pilot. "There's no question that she'll give us trouble. It's just a question of how much.

"The (ironic) thing about Harte is that she's not a great shooter," Butler said. "She just plays hella-shelter ball, stealing it from you and putting in garbage baskets. She's just everywhere you turn."

The Central coach said that his team must escape two possible negative circumstances if it's to advance in tournament play. "One is if their press destroys us," Butler offered. "We've got to break that press—and it's tough—or else it's all over."

"Number two: We've got to stop Harte."

Butler, who was clearly bent out of shape with the way his squad had performed in a sloppy 29-26 semi-final win over Milford Lakeland, said his club had to improve on that showing "by leaps and bounds" to beat the Bulldogs.

"We think we'll play better, and they've got to think that we'll play better," the coach said.

In an effort to realize that improvement, Butler said Monday that he'd be going out on a limb with a bold line-up switch. The coach said he would start 5-11 freshman Patty Fitzgerald in the

starting line-up at the forward slot, moving forward Caryn Lamb to a guard position "to help our perimeter passing."

The two finals foes met once earlier this season. That was the 1980 opener way back on September 9 when Harte led Brighton to a 61-60 overtime win.

TWELVE OAKS TIRE CO.
4290 Grand River
Novi 348-9699

Your Goodyear Dunlop Tire Pro

Floor Covering
Tile-Carpeting-Formica
100's of Samples
145 E. Cady Northville 349-4480

SPRUCE UP WHILE PRICES ARE DOWN

LAST WEEK SALE ENDS TUESDAY
30% OFF FACTORY LIST PLUS FREE CUSTOM GLAMOUR TOP WITH EVERY KITCHEN.

Belwood Cabinetry

STUDS
Construction Grade
2x4-7' 87**
2x4-92 1/2" 1.19**
2x4-8' 1.19**
ECONOMY GRADE
2x4-7' 59** 2x4-8' 79**

DRYWALL
4x8-1/2"
\$2.99*
JOINT COMPOUND
5 GAL. \$7.95*

FIBERGLASS INSULATION

KRAFT-FACED	SQ. FT.	ROLL
3 1/2 x 15 (48 S.F.)	R-11	13** 11.44
3 1/2 x 23 (138 S.F.)	R-11	13** 17.55
6 x 15 (45 S.F.)	R-19	21** 10.29
6 x 23 (79 S.F.)	R-19	21** 15.75
UNFACED	SQ. FT.	ROLL
6 x 15 (45 S.F.)	R-19	20** 9.80
6 x 23 (79 S.F.)	R-19	20** 15.00

REGULARLY PRICED FROM \$14.59 TO \$17.95 NOW ONLY \$8.99 TO \$10.79

COMBINATION STORM & SCREEN WINDOWS CUT ENERGY BILLS UP TO 24%*

Easy Do-It-Yourself Installation
Self-Storing
Tilt In For Easy Cleaning
FROM AS LOW AS \$19.95

CONSTRUCTION LUMBER

8'	10'	12'	14'	16'	18'	20'
2x4	1.19	1.79	2.19	2.39	2.99	3.65
2x6	2.39	2.49	3.69	3.99	4.75	5.49
2x8	3.49	4.35	5.95	6.19	7.09	7.79
2x10	4.09	5.45	7.29	8.59	9.75	10.15
2x12	5.99	7.98	10.60	11.83	14.35	17.00

DELIVERY AVAILABLE—FREE DELIVERY WITHIN 25-MILE RADIUS ON ORDERS OVER \$2000

STANLEY GARAGE DOOR U-Install™ OPENER

STANDARD OPENER
1/4 HP MOTOR
\$115.99*

*Light goes on when door opens, off when closed.

PINE CASHWAY LUMBER

Our low prices help you make it.

MT. CLEMENS 5 S. GROESBECK South of Cox Ave 469-2300	UTICA 48075 VAN DYKE Ber 21 Mile 272 Mile 739-7463	WEST SIDE 12222 INKSTER RD. Ber Plymouth & Schostcraft 937-9111	LINCOLN PARK 3255 FORT ST. Ber Southfield & Goddard 386-5177	FENTON 14375 TORREY RD. Torrey 51 Long Lake Rd 629-3300		
OPEN MON. THRU THURS. 8 a.m.-5 p.m. FRIDAY 8 a.m.-4 p.m. SAT. 8 a.m.-4 p.m. SUN. 10 a.m.-3 p.m.	SOUTH LYON 20801 PONTIAC TRAIL PONTIAC TRAIL & MILE 437-4161	DETROIT 5311 E. NEVADA Ber Ryan & Howard 348-1800	YPSILANTI 629 N. HURON 481-1500	WATERFORD TWP. 7374 HIGHLAND RD. Ch. 59 Ber Airport & Williams Lake Rd. 666-2450	BRIGHTON 525 MAIN ST. 1 Bid. W. of Grand River 227-1831	SOUTHFIELD 22800 W. 8 MILE 1 Mile E. of Telegraph 353-2570

Some items may not be available at all locations. All items Cash & Carry—Sale Items, marked with * Prices Good Nov. 26-Dec. 2

Christmas List Ideas

In Stock Sale - While Supplies Last

Store Hours through Christmas
MON.-THURS. FRI. SAT. SUN.
 8-6 8-9 8-6 10-5

Paragon Tree-liter
 Christmas Tree Light Control
 REG. 14.95 **4.88**

LOG CARRIER
 • FLAME RETARDANT
 • USE AS A RUG
 PROTECTOR FROM
 HOT SPARKS
 REG. 24.95 **14.88**

Log Storage Rack
HOLDS 1/2 FACE CORD
27.88
 Stores wood inside or out. Folds Flat.

LITE-A-LOG
 Starts your fireplace logs without effort or mess.
 Reg. 14.95 **6.88**

Custom Made RECESSED SCREEN
 45"-65"
 • BLACK • BRASS **19.88**
 • ANTIQUE BRASS

Custom Made CLASSIC HOODED FIREPLACE SCREEN
 TO 48" WIDE
 • BLACK • ANTIQUE BRASS • BRASS
 VALUES TO 89" **28.88**

Custom Made Canopy Type FIREPLACE SCREEN
 3 FINISHES AVAILABLE
 SIZES TO 42" SIDE
 REG. 39.95 **10.00**

ANTIQUE BRASS 38"x31 1/2" FIRE SCREEN
 REG. 49.95 **17.00**

FIREPLACE HEATING SYSTEM
 REG. 64.95 **38.88**
Freebird
 Turn every fireplace into a Mini-Furnace. Heat any room that has a fireplace. Excellent auxiliary heating unit. Cabins, Ski Lodge, Basement, Rec. Rooms, etc.
 16" Deep x 22" x 41" W. Other sizes available.
 • Electric Blower Attachment Available.

Save on "Custom Wroughts" Mitey **AMERICAN BEAUTY**
WOOD BURNER
 Regular 129.95
 Sale **68.00**
 Heavy gauge steel heating stove. Handy!

Log Roller
 Make your own fireplace logs. It's easy and simple to make your own logs from newspapers.
 Reg. 19.95 **9.99**

Magic Heat
 Save on Energy Use
 Capture and re-use the heat that normally goes up the chimney. Designed for use with free standing fireplace, wood, coal, gas or oil fired furnaces or space heaters.
 Reg. 19.95 **9.95**

FREE INSTALLATION
25%
STOP MONEY FROM GOING UP THE CHIMNEY.
 CUSTOM FIREPLACE GLASS DOORS
 F.O.B. MANUFACTURER

- THERMO-RITE
- PACIFIC
- REICHMAN
- HART
- CUSTOM FIRE
- HEARTH CRAFT

LAMPS PICTURES CLOCKS
Save 30%
 • QUOIZEL
 • BRITE-LITE
 • PITLOW
 • MARCREST ETC.

- CORNWALL
- ANSONIA
- NEW ENGLAND
- LINDEN, ETC.

PREWAY ZERO CLEARANCE 36" Built-In Fireplace Energy Miser
 Hurry, supply limited! Real wood burning, built-in fireplace. UL approved, that installs almost anywhere... easily installed. We have all class "A" chimneys in stock, too!
AT SPECIAL LOW PRICES
SAVE 40% 528.00 REG. 878.95 EMIV

POPCORN & CHESTNUT ROASTER
 Reg. 6.99 **4.99**

GLO-FIRE SAFE, REALISTIC GAS LOGS
SAVE 20% OFF ON ALL SIZES IN STOCK

- Can't tell the difference from real logs... with best!
- 100% automatic safety pilot.
- Immediate installation available.

Franklin FIREPLACE
 • 2-8x24 PIPE
 • SCREEN
 • ASH PAN
 • HEAD BAR
 REG. 299.00 **138.00**

EXTRA SPECIAL! AMERICAN SPREAD EAGLE
 Huge 19 inch wing spread! Black, milled aluminum. Hangs on back... ideal for rec. room, den, fireplace, a fine addition for your home.
 19" Only **4.99** Reg. 9.95

GLO-FIRE GLASS DOORS
 ALL SIZES ALL FINISHES IN STOCK
27.00

9.88 FIREPLACE GRATES
 • STEEL BAR
 • 28" WIDTH
Only 4.77
BLACK WOOD BASKET
 REG. 19.95

WALL HANGING TOOL SET
 4-PC. Antique Silver
19.88 REG. 39.95

3 HR. FIRE LOGS NORTHLAND
 6 PER CASE
5.97 CASE

25 LB. FIREPLACE COAL
2.99
 GOOD STOCKING SETOFFER
 Reg. 4.99

WOODEN FIREPLACE MANTELS
 ALL SIZES IN STOCK

50% OFF

BLACK COAL SKUTTLE
9.99

FIREPLACE TONGS
 Reg. 7.95 **4.99**

REAL BRICK BRICKETTES
 6 Styles in Stock
6.99 comes 6 sq. ft. per box
 Homestead

ENTIRE STOCK FREE-STANDING FIREPLACES
 • U.S. STOVE
 • FISHER
 • ATLANTA
 • KALAMAZOO
 • PREWAY
Your Choice 30% OFF

EVERYTHING YOUR HEARTH DESIRES
HEARTH SEALER
 Protects brick, stone or tile from staining, shedding or flaking.
HEARTH CLEANER
 Cleans soot, lime scale or alkali from brick, stone or tile.

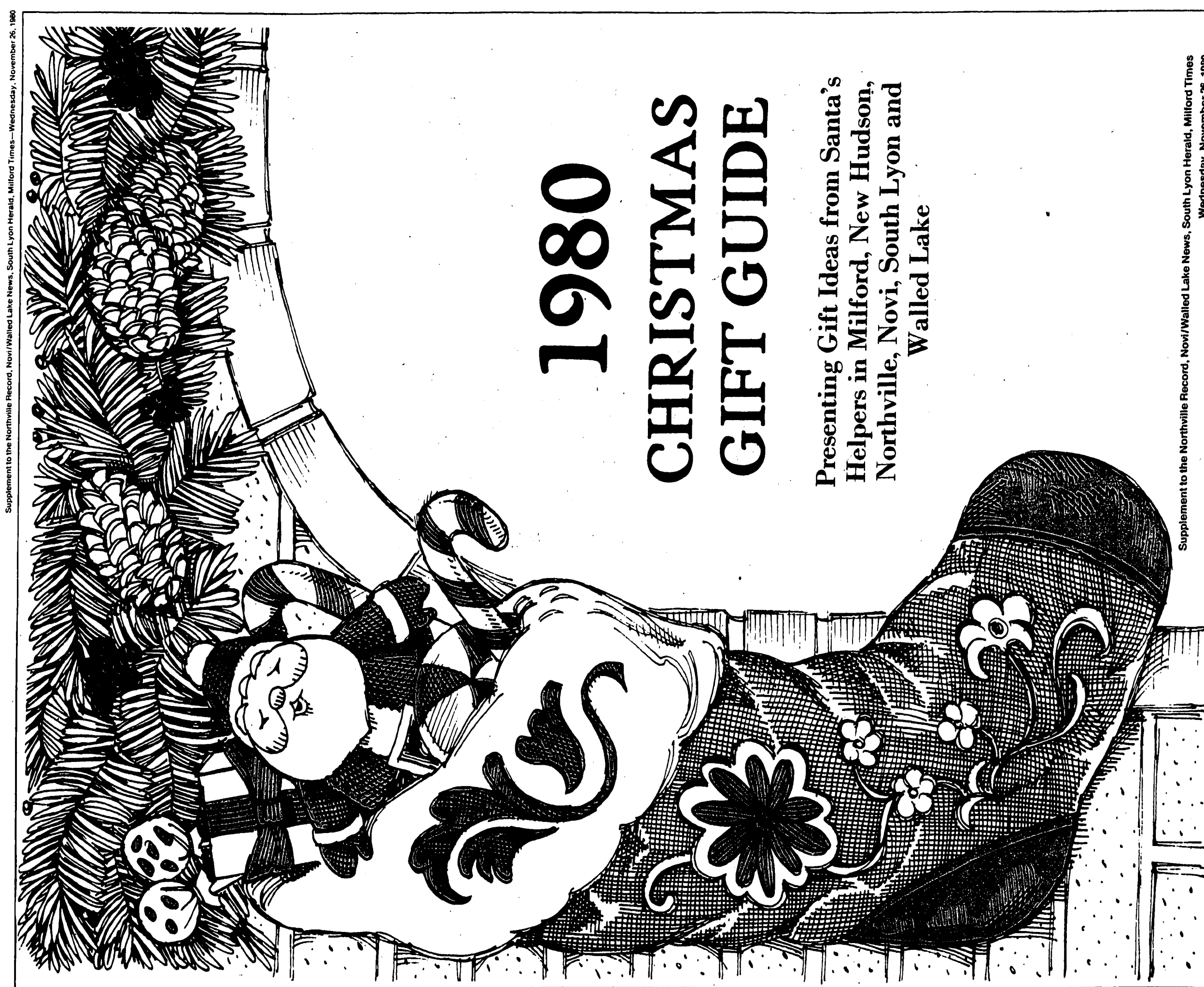

1980 CHRISTMAS GIFT GUIDE

Presenting Gift Ideas from Santa's Helpers in Milford, New Hudson, Northville, Novi, South Lyon and Walled Lake

LOAD UP ON GREAT GIFTS

At These Prices it's the Right Time To

COUPON \$2.00 OFF ANY LADIES' SWEATER
 IN STOCK Good thru 12-15-80

COUPON \$5.00 OFF ANY ELECTRONIC GAME IN STOCK
 Retail: 26.99-38.99 Good thru 12-16-80

OUR CHRISTMAS FEATURE Gift Wrap 83¢
 30 or 35 sq. ft. roll

25 Cnt. Pkg. BOWS 79¢
 18 Pak or 12 Pak

Candy Canes 99¢

CHRISTMAS Cookie Cutters 29¢
 GREAT SELECTION OF Dolls and Cuddly Soft Stuffed Animals

COUPON \$99¢ To \$1.99
 METAL Cake & Candy TIN BOXES
 CHRISTMAS Cookie Cutters

STOP IN, BROWSE, ENJOY THE FUN OF A VARIETY STORE AT CHRISTMAS OPEN TIL CHRISTMAS 9-9 starting DEC. 1st

VARIETY STORES INC. SINCE 1926
 200 N. Lafayette Milford 685-8474
 138 E. Main Northville 348-9861
 411 N. Main Milford 685-8474
 1160 E. West Maple Rd. Walled Lake 624-3822

Use our convenient Lay-away Plan—Small deposit with regular payment will hold 'til Dec. 15th

American

HARDWARE LUMBER & SUPPLY COMPANY
 MICHIGAN'S MOST UNUSUAL HARDWARE STORE
 31245 EIGHT MILE ROAD CORNER MERRIMAN
 LIVONIA MONDAY THRU SATURDAY 8 a.m. to 6 p.m. 476-6243
 SUNDAY 10 a.m. to 4 p.m.

CHRISTMAS STORE HOURS
MON.-THURS. 8-6
FRI. 8-9 SAT. 8-6
SUN. 10-5

Supplement to the Northville Record, Northville Lake News, South Lyon Herald, Milford Times, Wednesday, November 28, 1980

SPENCER'S DRUG STORE
 111 S. Lafayette
 South Lyon
 437-1775
 HOURS: Mon.-Sat., 9-10; Sunday 10-6

VIDEO COMPUTER SYSTEM™ BY ATARI®
 Your Video Computer System™ comes with the "Combat" Game Program™ cartridge—27 exciting video game variations. And the package is complete with everything you need to run your flick of a switch.

Reg. \$139.95

WATCH
 Sharp Musical Calculator
 Pocket-size full function, 8 digit calculator with percent and memory. Operates with or without touch sound. With case and batteries.

Dec. 3rd
 our
 Watch

Christmas Roll Wrap 99¢
 3 Roll Pack

Timex Watches 10% Off
 \$1.79 Plus Deposit
 8 Pack SPECIAL 1/2 Liter Bottles
 Nov. 28th & Nov. 29th
 Take the Pepsi Challenge Friday & Saturday

We Have All Your Christmas Needs

Arms Brothers
 361 N. Main 654-4115
 Store for Men Since 1877
 MILL FORD VISA

WELCOME
 LAY-A-WAYS
 CAREER CLUB
 HAGGAR
 CRICKETER
 LEVI
 JANTZEN
 PENDLETON

Merry Christmas
 MAKES IT EASY TO SAY...
 Top-quality menswear at prices that make it easy to save!

Arms Brothers
 361 N. Main 654-4115
 MILL FORD VISA

Symbols of Christmas have varied meaning

For all of the many symbols of Christmas—wreaths, holly leaves, mistletoe, and the holly berries—each has a special significance of the holiday season observed.

From large cities to the remote villages in hands both near and far, a spirit of good cheer prevails among the people.

There is great excitement as age-old customs are followed in preparation for the holiday celebration, and though the holiday celebration and though the customs may differ from land to land, the holiday sentiment remains much the same in many cultures.

Midwinter had always been a season of joyous celebration in ancient civilizations. The Romans paid tribute to their winter deity, Saturnus, during the winter season of Saturnalia.

It was a week-long festival, marked by processions, gift-giving, feasting and decorating the home with holly and evergreens.

In winter also, the Hebrews celebrated the Festival of Lights, or Hanukkah, which is still observed today by people of the Jewish faith. It is a holiday of about 1 1/2 gallons, enough for 30 to 40 people, served in 6 ounce cups.

FOX
 105 N. Center
 348-0303
 MONTICELLO

FOX
 105 N. Center
 348-0303
 MONTICELLO

Portrait Studio, Inc.
 A unique thoughtful gift from \$14.95

Pet Portraits
 A unique thoughtful gift from \$14.95

Fish House Punch

The following recipe for Fish House Punch, favorite treat of the Henry Ford Museum and Greenfield Village, is one of the most potent and one of the best originated in 1732 with that famous old Philadelphia Club called the "Slate in Schuykill".

If the one below given is not the original recipe, it at least comes very close to it. It is a still punch—that is water and cold before mixing with other ingredients which also have been chilled thoroughly. Keep under refrigeration until served.

Makes about 1 1/2 gallons, enough for 30 to 40 people, served in 6 ounce cups.

12 ounces sugar
 32 ounces lemon juice
 3 fifths rum
 1 1/2 fifth cognac
 1 1/2 fifth brandy
 6 ounces peach brandy

1. Dissolve sugar in proper amount of water and cold before mixing with other ingredients which also have been chilled thoroughly. Keep under refrigeration until served.
 2. Add yeast to lukewarm water and dissolve.
 3. Add eggs to mixing bowl with 1/2 pound butter.
 4. Add eggs to mixing bowl with 1/2 pound butter.
 5. Add remaining flour very slowly, mix at medium speed for 5 minutes.
 6. Add 1/2 cup sugar, whole wheat flour to step 1, 2 and 3, mix and white flour to step 1, 2 and 3, mix.
 7. Pan dough in 1 pound loaves. Let rise until double in size again.
 8. Bake in 350 degree oven for 35 to 40 minutes. Use vertical mixer only or mix by hand.
 9. Heat milk, butter and margarine, melt. Add salt and sugar to this mixture. Let cool to room temperature.

1. Heat milk, butter and margarine, melt. Add salt and sugar to this mixture. Let cool to room temperature.
 2. Add yeast to lukewarm water and dissolve.
 3. Add eggs to mixing bowl with 1/2 pound butter.
 4. Add eggs to mixing bowl with 1/2 pound butter.
 5. Add remaining flour very slowly, mix at medium speed for 5 minutes.
 6. Add 1/2 cup sugar, whole wheat flour to step 1, 2 and 3, mix and white flour to step 1, 2 and 3, mix.
 7. Pan dough in 1 pound loaves. Let rise until double in size again.
 8. Bake in 350 degree oven for 35 to 40 minutes. Use vertical mixer only or mix by hand.
 9. Heat milk, butter and margarine, melt. Add salt and sugar to this mixture. Let cool to room temperature.

South Lyon
 437-1567

112 E. Lake
 (Formerly Spencer Drug Store)

BARKER'S GIFTS AND IMPORTS

Visa and MasterCard honored
 Layaway available
 We now have Hummels
 of Christmas gifts
 We have a large variety

COUPON
 Worth \$10.00 Off
 on a
 NORMAN
 ROCKWELL
 FIGURINE
 Barker's
 Gifts & Imports

Gristmill Bread

1. Heat milk, butter and margarine, melt. Add salt and sugar to this mixture. Let cool to room temperature.
 2. Add yeast to lukewarm water and dissolve.
 3. Add eggs to mixing bowl with 1/2 pound butter.
 4. Add eggs to mixing bowl with 1/2 pound butter.
 5. Add remaining flour very slowly, mix at medium speed for 5 minutes.
 6. Add 1/2 cup sugar, whole wheat flour to step 1, 2 and 3, mix and white flour to step 1, 2 and 3, mix.
 7. Pan dough in 1 pound loaves. Let rise until double in size again.
 8. Bake in 350 degree oven for 35 to 40 minutes. Use vertical mixer only or mix by hand.
 9. Heat milk, butter and margarine, melt. Add salt and sugar to this mixture. Let cool to room temperature.

PRECISION WATCH & RING SMITH
 TWELVE OAKS MALL 2nd Level Sears Side 349-0780

45% OFF
 ON 14 KT and 18 KT

FREE Gift of Jewelry Polishing Cloth
 No purchase necessary

Chains
Charms
Bracelets

20% OFF ALL
 Watches and Pocket Watches

14 Kt Floating Heart \$5.00

14 Kt Herringbone Bracelet \$9.00

20% OFF
 on Orange Blossom Diamond Rings

20% OFF
 14 Kt Earrings
\$5.00
 Includes Starters

FREE Engraving while you Wait
We Buy Old Gold

Holiday Special EAR PIERCING \$5.00
 Includes Starters

LARGE SELECTION OF LOOSE DIAMONDS
JEWELRY DESIGNING-EXPERT WATCH REPAIR-ALL CUSTOM WORK-
WE WILL SERVICE ALL YOUR JEWELRY NEEDS

Master Charge VISA

PRECISION WATCH & RING SMITH
 TWELVE OAKS MALL 2nd Level Sears Side 349-0780

TWIST & SET THE EASIEST YET
 The highly Evolved Citizen

The streamlined new Ana-Digi. The first dual mode watch with 3 hands in the analog display. Digital functions include:

- Stopwatch up to 24 hours.
- Countdown timer, alarm, chime.
- Night light.

FREE Gift of Jewelry Polishing Cloth
 No purchase necessary

THE EMBRACEABLE BRACELET - BY CITIZEN!

Choose from an alluring array of beautiful bracelets that enhance some of the world's loveliest, superbly accurate quartz timepieces. Designed to embrace the curve of your wrist.

LARGE SELECTION OF GOLD CHAINS BRACELETS CHARMS

41-8021 yellow \$275.00

88-5126 (yellow) \$225

88-4022 (yellow) \$225

49-1365 (yellow) \$175

CITIZEN

FREE ENGRAVING WITH PURCHASE
 Large Selection of Gold Chains-Bracelets-Charms
 JEWELRY DESIGNING - CUSTOM WORK
 EXPERT WATCH REPAIR- SELECTION OF LOOSE DIAMONDS

Master Charge VISA

E.R.'S SADDLERY
SUNDAY 1-5
FRIDAY & SATURDAY 9-9:30
HOURS: MONDAY-THURSDAY 9-9:30
AT
SHOP
WESTERN & ENGLISH
TACK & RIDING APPAREL
PHONE 437-2221
SOUTH LON, MICHIGAN 48778

It's time to send our LTD
Holiday Glow
Bouquet
Brighten up the season with our
festive arrangement of fresh
flowers and greens in an exclusive
call or visit us now.
Floral by Steven
102 N. Lafayette
437-0010
South Lyon
M. Nowicki, Consultant
Helping you say it right!
\$17.50
and
up

HIGHLAND OUTDOOR CENTERS
TWO DAY
CHRISTMAS SPECIAL
FRIDAY & SAT. NOV. 28 & 29th
Homelite Super E-Z
16" Bar & Chain
Reg. \$28.95
Save \$8.00
Homelite 330-16" Bar
13.50 Oil, In. Engine Reg. \$29.95
Auto Oiling
Plus FREE Case
Reg. \$28.95
SALE \$22.95
Homelite Super X-1-16" Bar
13.50 Oil, In. Engine Reg. \$29.95
Auto Oiling
Heavy Duty
Save \$4.00
Homelite 350-20" Bar
13.50 Oil, In. Engine Reg. \$39.95
Auto Oiling
Save \$9.00
OFFER GOOD FOR FR. & SAT. NOV. 28 & 29 ONLY
Reg. \$3.00 SPECIAL \$3.00
12" Chain \$1.95
14" Chain \$2.95
16" Chain \$3.95

Christmas OPEN HOUSE
THURSDAY, DECEMBER 4th
6 to 9 P.M.
Downtown Milford
Refreshments will
be available at most
participating stores.
Visit with SANTA at
Fashion Flooring
from 6 to 9.
Entertainment by
School Bands &
Choral Groups
Make Milford
your first stop for
Holiday Gift
Shopping and
Old-Fashioned
Christmas Fun

Donna's Boutique
WE HAVE A FINE
SELECTION OF
WOMEN'S, MEN'S
AND CHILDREN'S
MERCHANDISE
LEFT FOR YOU TO
PICK FROM
WE WILL WRAP
YOUR CHRISTMAS
PURCHASE FREE
STORE HOURS:
Mon, thru Fri. 9-5 pm
Saturdays 9-5 pm
120 E. Lake South Lyon
437-1740
DON'T FORGET 28 SHOPPING DAYS LEFT
WE WILL WRAP
YOUR CHRISTMAS
PURCHASE FREE

TO BE USED AS CASH
WHEN MAKING PURCHASE
CHRISTMAS BONUS COUPON
SAVE UP TO 10% OFF WITH
THIS COUPON
LIMITED TO ONE TOTAL SALE
EXPIRES DECEMBER 1, 1980
MUST BE PRESENTED WHEN BUYING TO SECURE DISCOUNT
Worth \$20.00 on a purchase of \$200.00 or more
Worth \$15.00 on a purchase of \$150.00 or more
Worth \$10.00 on a purchase of \$100.00 or more
Worth \$5.00 on a purchase of \$50.00 or more
Worth \$2.50 on a purchase of \$25.00 or more

Stores
at all
Savings Time
Christmas
It's
Donna's
Boutique

There's lots of substitutes for turkey
Are you tired of turkey?
Area residents begin to look forward to the big bird somewhere around October when the fall harvest of pumpkins, squashes and cranberries fills the shelves in anticipation of Thanksgiving.
Most cook the turkey on that last Thursday in November with a table that should rightly be called a "grooming board."
Then, with Christmas shopping, decorating parties and all the other preparations for the season, we give the thought to a Christmas feast that could be a shade different.
Not only is it traditional to present turkey with all its trimmings, it's easier.
But, really, a crown roast of pork or lamb, stuffed in the center with its own ground meat, nuts and cranberries and accompanied by Yorkshire pudding, is not difficult to fix.
A German sauerbraten marinated in ginger snaps, an English standing roast of beef accompanied by Yorkshire pudding, a French breast of veal stuffed with ground pork, rice and olives may require a little more time, but each is well worth the effort.
Recipes for all these treats are available in any good basic cookbook.
For those whose families would go in-
Continued on Page 6

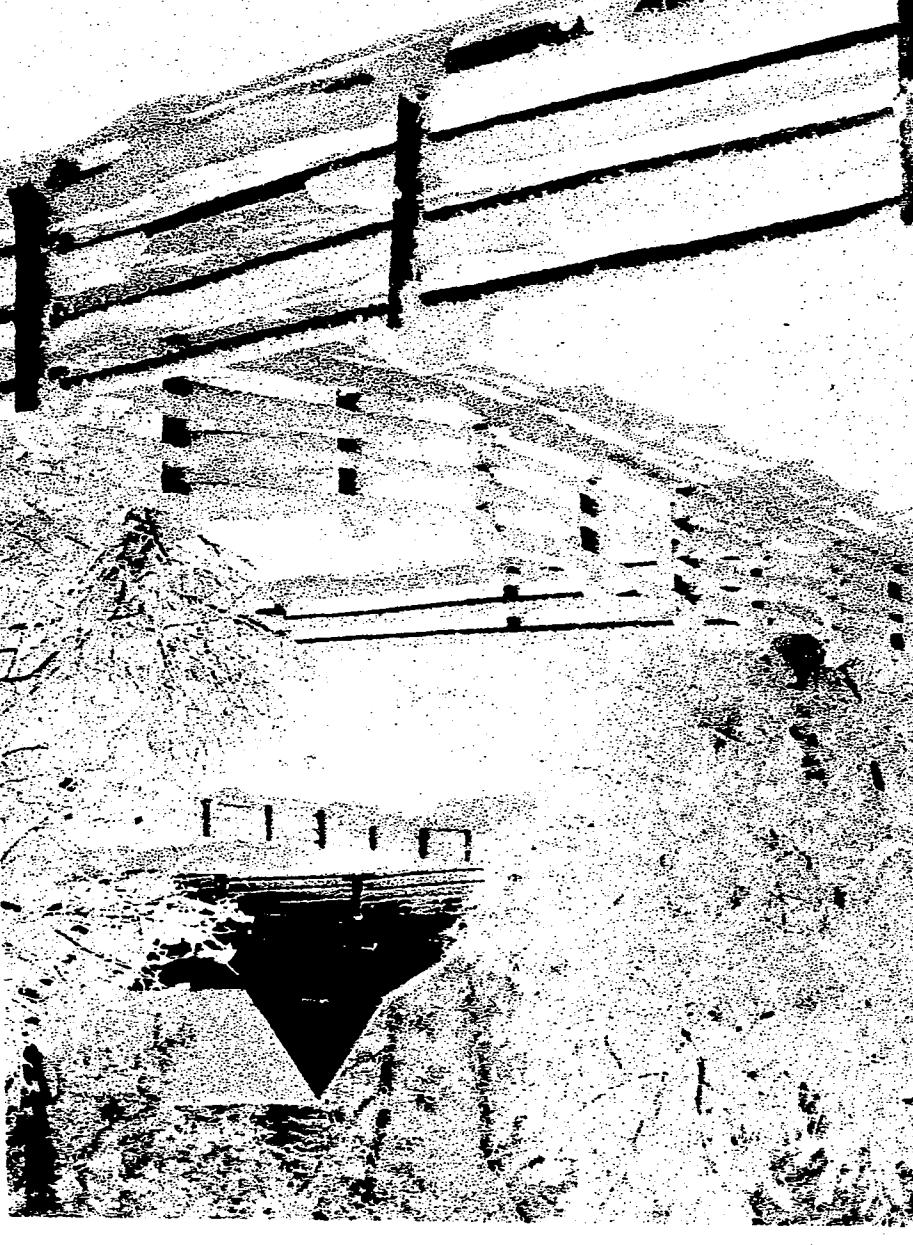

Symbols have varied meaning

Continued from Page 3
Therefore the Jews observe Hanukkah for eight days in honor of this miracle.
Winter rites
Similarly, wintertime festivities took place in early Egyptian and Greek civilizations. The Goths, Saxons and Druids of the northern lands all celebrated the arrival of the winter solstice with great feasting and sacred rituals.
These pagan rituals eventually melded with the Christian celebration of the birth of Christ, and the season's
festivities took on an international character as Christianity grew in acceptance throughout the centuries.
At first, the Church resisted observation of pagan rituals but, failing in that attempt, it incorporated the forms into the Christian celebration.
Custom of gift-giving
Perhaps the most well-known and widespread of all Christmas traditions is the practice of giving gifts.
The early Romans made gifts to their emperors during Saturnalia; the three wise men, or Magi, brought gifts of gold, frankincense and myrrh to the Christ child; and an archbishop from Lycia brought the gift of faith to many.
This generous archbishop from Asia Minor was the good Saint Nicholas, or Santa Claus, the patron saint of girls and boys.
Children all over the world write to him at his home at the North Pole with their gift requests, a practice which has been abstracted from a Germanic legend.
The symbols of Christmas are both sacred and secular. From special holiday cakes to the star on the Christmas tree, from sidewalk Santas to the scene of the nativity, the mix of pagan and Christian symbolism is thorough.
Celtic traditions
Kissing under the mistletoe stems from ancient Celtic tradition.

Decorating the tree — in early times, with fruits and sweets — stems from an early Germanic worship of vegetation.
Sending Christmas greetings to friends and associates to express friendship and good-will first came about in Victorian England.
An English first
Queen Victoria's husband, Prince Albert, introduced the first Christmas tree in England from his native Austria in 1841.
Centuries-old customs have been handed down in a spirit of heart-warming brotherhood. Children grow excited at the thought of Santa's visit, or the chance to sit on his knee at the local department store.
Singers both young and old venture out into the crisp night, filling the air with the sweet sounds of Christmas carols.
College students gather in the dorm lounge, surrounded by bowls of popcorn, needles and thread, red and green ribbons, and an eight-foot tree waiting to be decorated.
Heart-warming season
Very few hearts escape being touched by the spirit of Christmas. Bustling commuters don't seem as easily bristled during the holiday season.
The mailman steps a little lighter, despite the increased weight in his bag. Teachers give less homework. Mothers
allow their babes an hour or two longer before bedtime.
Christmastime is time to take stock of the good things in life; the simple pleasures, the comforts, the blessings of family and friends.
Pleasures of memory
And, when the 12 days of Christmas have passed, and the decorations return to their boxes until next year, there always is the lingering pleasure in remembering all those smiling faces and dancing eyes in his bag, the true symbols of holiday happiness.

Amber
Timeless Jewelry to be Appreciated
McMartin's Jewelry
Since 1955
Celebrating our 25th Anniversary
Milford 684-8895

Random House Interiors
COMPLETE YOUR ROOM FOR THE HOLIDAYS BY ACCESSORIZING WITH BEAUTIFUL PICTURES, NETTLECREAK PILLOWS AND ACCENT PIECES.
WE'RE ALL NEWLY DECORATED. PLEASE VISIT US FOR THE FINEST GIFT SELECTIONS.
NOVI—TEN CENTER
41706 WEST TEN MILE—NOVI
348-6061 MON-SAT 10-6 EVENINGS BY APPOINTMENT



Holiday child
Their future may, perchance, appear dark to others; but to their fearless gaze it looms up brilliant and beautiful as the walls of a fairy palace.
There is no tear which a mother's gentle hand cannot wipe away, no wound that a mother's kiss cannot heal, no anguish which the sweet murmuring of her soft, low voice cannot soothe.
Esaia's Tegner

All HO Athearn
Kits and Engines
15% off
Clothing Closeout
40% off
We carry:
Needlework
Craft Items
Race Sets
Model Kits
Radio Control

THE HOBBY EMPORIUM
9541 Main St.
Whitmore Lake
(Under New Ownership)

For a sparkling Christmas...
Gift Sale
All Fine Jewelry
20% off
Friday, Saturday & Sunday
diamond boutique
"Custom Made Jewelry Exquisitely Designed to be Exclusively Yours"
37105 Grand River Avenue
Farmington, Michigan 48024
Phone: 478-3131
Great Oaks Mall
1250 Walton Boulevard
Rochester, Michigan 48063
Phone: 651-8251

Fireplaces Plus

WESTLAND CENTER
WESTLAND
NOVI
TWO E. OAKS MALL
348-8888
322-2229

Unique Gifts...
for Beautiful Homes

Fireplaces-plus
FIREPLACE ACCESSORIES
UNUSUAL WALL DECORATIONS
LIGHTING FIXTURES
AND MANY OTHER ITEMS

Come in and browse

**NO ONE BEATS
IN GOLD
SELECTION**

30% OFF

All 14 kt
gold
Chains
and
Bracelets
Charms

Michael's Jewellery

348-9380
West Seven Mile Road-Northville
NORTHVILLE PLAZA MALL

Imported To You Directly From Italy With No Middlemen!
Select the weight and length that best accentuates your sensuous style.

**Post Thanksgiving
Fabric Sale**

Friday, Nov. 28
Saturday, Nov. 29
10 to 5

on Exceptional Savings
on Exceptional Fabrics

VELOUR, SOLIDS AND HEATHERED
VELOUR, STRIPES and patterns
now \$11.50
were \$15.50 to \$18.50

PLUSH TERRY... was \$5.50
now \$4.50

A group of fabulous kiddie kits, complete with neckerchiefs—20%
Other Terris, Quilted Fabrics, Gitters,
Quiana—at savings
of 20% to 40%

PLUS... FREE Demonstration of our popular Ribbed Dolman Top
—both Sale Days. Call the store
for particulars: 477-8777

The Ann Person Method
FABRICS CENTER
3553 W. 10 Mile Road, in the Freeway Shopping Center
Farmington

**Coming to
Santa Claus is
Bakman Florist**

Saturday, Nov. 29
Dec. 13 and Dec. 20

Be sure to visit us for the special of the day
Christmas decorations
and Holiday Arrangements

BAKMAN FLORIST

22452 Pontiac Trail
South Lyon
437-4168

AN
OPENING
DECEMBER 1
ARTCRAFT OUTLET
IN NORTHVILLE
332 E. Main
Northville
Call 342-2219

**Both IV Seasons Flowers
and 5th Season**

can help you find all the things
that make Christmas a very
special time of year for sharing
Holiday arrangements
Christmas trees
Special Gifts
Flowering Plants and Fruit Baskets

IV Seasons
Flowers
149 E. Main St.
Northville, Mich.
349-0671

5th Season
140 Kerry Alexander Ct.
Northville, Mich.
346-0300

Village decorated, too

In the picturesque Town Hall on the
Village Green visitors pause for a warm
complimentary cup of hot spiced
and the sweet odor of early boiling on
the wood stove to the festive homeside
recall the days when such Christmas
preparations were commonplace.
In the 19th-century Pympton House,
The Christmas observance continues
through the month of December, except
field Village, the traditions of St.
Nicholas Eve as observed by the early
settlers are stressed.

Continued from Page 13

Substitutes for turkey

The advent of Christmas evokes excitement and pleasure in virtually everyone, and the family pet is as likely to be affected by all the activity and preservative in the water at its base. Cats, particularly, are notorious samplers and, after all, you wouldn't want your pet drinking water contaminated with their chemicals.

—Many people feel that a tree is not complete without garlands of lights. If you hang up this garland, you have a cat or dog, be careful not to leave the animal unattended in the vicinity of the tree. If possible, stand the tree in a room that can be locked off.

—Stay away from breakable Christmas tree ornaments. Besides the mistletoe and poinsettia, are poisonous. If you have pets—or young children—make sure you're wise to hang these ornaments on leaves splinters about the tree.

—Candles add a special glow to holiday parties and even quiet winter evenings at home.

—If you have a natural Christmas tree, you're better off not using a waterless put through a food processor and a dash of nutmeg, a little or a lot.

—Try an elegant, light cream of water-cress soup (canned chicken broth, watercress put through a food processor and a dash of nutmeg, a little or a lot).

—A group of fabulous kiddie kits, complete with neckerchiefs—20%.

—Other Terris, Quilted Fabrics, Gitters, Quiana—at savings of 20% to 40%.

—PLUS... FREE Demonstration of our popular Ribbed Dolman Top—both Sale Days. Call the store for particulars: 477-8777.

—The Ann Person Method.

—FABRICS CENTER.

—3553 W. 10 Mile Road, in the Freeway Shopping Center.

—Farmington.

Christmas is great for pets, but...

Page 6 Gift Guide—Wednesday, November 26, 1980

Page 14 Gift Guide—Wednesday, November 26, 1980

Page 6 Gift Guide—Wednesday, November 26, 1980

Page 6 Gift Guide—Wednesday, November 26, 1980

Page 7 Gift Guide—Wednesday, November 26, 1980

ELIAS A. BROWN.

Greenfield Village buildings wrapped in holiday past

Yule log rooted in ancient past

Of the many Christmas traditions that have survived through the ages, one of the most ancient is the ceremonial lighting of the Yule log on Christmas eve.

It is a tradition that is more strongly rooted in European culture than in our own, yet it is not uncommon for an American family—including those in this area—to gather around the hearth on Christmas eve, sipping eggnog and watching flames dance.

Ancient tradition

This ceremony dates back to the time of the Saxons and Goths, as well as the early Germanic tribes, who burned such a log at their festival of the winter solstice.

The log was often a stump or root of a tree that had been obtained from one's own land or a neighboring woods, and which was brought into the house not to be affected by all the activity and preservative in the water at its base. Cats, particularly, are notorious samplers and, after all, you wouldn't want your pet drinking water contaminated with their chemicals.

—Many people feel that a tree is not complete without garlands of lights. If you hang up this garland, you have a cat or dog, be careful not to leave the animal unattended in the vicinity of the tree. If possible, stand the tree in a room that can be locked off.

—Stay away from breakable Christmas tree ornaments. Besides the mistletoe and poinsettia, are poisonous. If you have pets—or young children—make sure you're wise to hang these ornaments on leaves splinters about the tree.

—Candles add a special glow to holiday parties and even quiet winter evenings at home.

—If you have a natural Christmas tree, you're better off not using a waterless put through a food processor and a dash of nutmeg, a little or a lot.

—Try an elegant, light cream of water-cress soup (canned chicken broth, watercress put through a food processor and a dash of nutmeg, a little or a lot).

—A group of fabulous kiddie kits, complete with neckerchiefs—20%.

—Other Terris, Quilted Fabrics, Gitters, Quiana—at savings of 20% to 40%.

—PLUS... FREE Demonstration of our popular Ribbed Dolman Top—both Sale Days. Call the store for particulars: 477-8777.

—The Ann Person Method.

—FABRICS CENTER.

—3553 W. 10 Mile Road, in the Freeway Shopping Center.

—Farmington.

BUDGET FRIENDLY GIFTS FOR CHRISTMAS

J-Ann's Shop

BLOUSES	Sizes 4-20	\$9.98-\$16.98
FASHION PANTS	Sizes 8-18	\$10.98
"BEND-OVER" SLACKS		\$14.98
SWEATERS		\$7.98-\$24.98
QUEEN BLOUSES	36-44	\$10.98-\$19.98
QUEEN SLACKS	20-44	\$6.98

TOP QUALITY MERCHANDISE... CLOTHING FROM THE CAROLINAS... AT LOW, LOW, PRICES

Nikki, Bonworth, Ades of Calif.,
Eileen, Exquisite Form Bras **10% Off**

M., W., Sat. 10-6
T., Th., F. 10-5

1328 S. Commerce
Walled Lake 689-9130

Hello... Yes!

I STOP AT THE
PINEAPPLE SHOPPE TO

FILL MY
PACK!

The Pineapple Shoppe

Fine Gifts of Hospitality
514 North Main Street
Milford 685-9164

OPEN (Beginning Mon., Dec. 1) Mon. thru Fri. 10 to 9 Sat. 10 to 6

FREE

1 Can Bar & Chain Oil
1 Can 2 Cycle Oil
1 File & Handle
1 Wedge
1 Woodcutter's Book
1 Case (Some models)

STIHL
The World's Largest Selling Chain Saw.

**Can the woman who picks
out your ties be trusted to
pick out your chain saw?**

Picking out a tie or a shirt is one thing. But when someone picks out a chain saw for you, they better know exactly what to look for.

Like the quality and precision that go into a Stihl, the world's largest selling chain saw.

So tell her what to look for. Tell her to compare. It's the only way to be sure you'll get a Stihl under the tree.

Priced from \$149.95

Gardiner, Inc.

41843 Grand River Novi
1/2 MILE EAST OF NOVI ROAD 348-3393

Schrader's presents Cherry Towne

INCLUDES:

- 66" Dresser
- Jewel Box Tray
- Mirror
- Chest on Chest
- Queen or Full Size Poster Bed

**\$1699 Value
SALE PRICE
\$1399**

Tops, drawer fronts and ends are solid, not veneers. Even the backs, drawer bottoms and dust proofing are genuine wood. Traditional cherry finish and heirloom design. Heavy plate glass mirrors and distinctive pulls. Solid quality throughout. Open stock availability.

Prices include delivery and set up in your home

Schrader's Home Furnishings

Serving the Area from the same Location "Since 1907"

111 N. Center (Sheldon) Northville 349-1838
Mon., Tues., Sat., 9, 10, 6; Thurs. & Fri. 9 to 9; Closed Wed.

Finest Quality Grand Rapids Bedding At Special Prices with Purchase

**REAR END
CUSTOM DESIGN STUDIO**

Unusual Gifts & Art Objects
Gift Certificates Available

STAINED GLASS SUPPLIES

112 S. Milford Rd Highland, Mi.
887-8240

PLUMBERY
HOME CENTER
OAKLAND HARDWARE
SANTA'S SHOPPING CENTER

988 For Accuracy in Drilling
Block & Locking Drill Guide
SAVE 4.00!

5988 CENTRAL CONTROL SYSTEM
Includes TWO MODULES
Control lights and appliances in your home
Control lights and appliances in your home

2488 SALE PRICE
LANTERN
REG. 2.99
MFG. REBATE
7.50
REG. 4.66

12997 MOTORIZED TABLE SAW
8 Inch Bench Top
REG. 23.99
SAVE 13.51

1288 WEATHER STATION
REG. 23.99
SAVE 13.51

2775 HAGGERTY RD., WALLED LAKE 969-2022

20% to 50% SAVE
Fashion Boots
Moon Boots
for Women - Children - Men

BOOT SALE
To Choose From—Many Styles
All Winter Boots—Nothing Held Back

SALES 19750
REG. 224.95
SALE 161.95

XL 12" CHAIN SAW
REG. 144.95
SALE 99.95

SALES 19750
REG. 224.95
SALE 161.95

NEW HUDSON POWER
5335 Grand River at Haas Rd.
2 miles west of Wixom Road
Hours: Mon.-Fri. 9-6, Sat. 9-1

99 CASH & CARRY
From All Sizes Sale

Bar & Chain Oil
LIMITED QUANTITIES
7/8" Chain Loop only
24" 11L 22.33
20" 70L 13.55
14" 59L 11.95
12" 48L 9.95

Specials
Saw Chain
REG. 12.99
SALE 9.95

BUY HIM A HOMELETTE
CHAIN SAW
REG. 144.95
SALE 99.95

437-1444

Gift Certificates
Available
• ARTS & CRAFT SUPPLIES
• BASKET WEAVING
• TOLE PAINTING
• DRIED & SILK FLOWERS

2961 E. HIGHLAND RD., HIGHLAND 887-5445

Mexican delight
Scarlet flower

Continued on Page 10



Although the poinsettia plant is not indigenous to the United States, Michigan-Nicholsiana (flower of a Mexican legend) has come to associate its red bracts with the Christmas season.

The plant was actually introduced in 1828 to the service honoring the birth of the States in 1828 by Dr. Joel R. Poinsett, at that time the U.S. ambassador to Mexico, for whom the plant was named.

Poinsettias grew wild in Mexico, reaching the height of their splendor just around the third week of December.

Wednesday, November 26, 1980—Gift Guide Page 9

Wednesday, November 26, 1980—Gift Guide Page 13

A short cut to peanut brittle

Everybody loves the holiday season—it's the time of year when friends and family are busily preparing special mouth-watering goodies to share with others.

Old-fashioned peanut brittle is one tempting treat that has been a yuletide favorite through the ages.

"Even nicer," say the economists, "delicious peanut brittle can now be made quickly and easily in a microwave oven. No more stirring constantly and checking closely until the mixture reaches the proper temperature."

Quick-cooking

The following recipe takes only nine minutes to prepare in a microwave oven, and it's so good you'll want to make several batches for gift-giving, too.

(And if you don't have a microwave, perhaps saving the "brittle recipe will remind your spouse that it's gift-giving time.)

OLD FASHIONED PEANUT BRITTLE

1 cup raw peanuts
1/2 cup sugar
1/2 cup white corn syrup
1 tsp. salt
1 tsp. baking soda
1 tsp. vanilla
1 tsp. butter

In a 1 1/2-quart casserole, stir together peanuts, sugar, syrup and salt. Cook for 10 minutes at HIGH, stirring well after four minutes.

Add butter and vanilla. Cook one minute longer at HIGH. Add baking soda and quickly stir until light and foamy.

Immediately pour onto lightly buttered baking sheet.

Spread out thin.

When cool, break into pieces. Store in air-tight container.

attempt, superstition held that ill luck would follow.

To further ward off ill fortune in the coming year, the log had to burn for at least 12 hours. A portion of the extinguished log was then saved for the following Christmas, often stored in the house as a protection against lightning.

At Greenfield Village
Past holiday treats re-created

The Greenfield Village Christmas observance is an experience from out of the past.

It is sleigh bells and carolers, holiday cookies and hot, spicy cider.

It is bougths of holly and flickering candles, old-time trees and stockings hung by the chimney with care.

Beginning early in December, the Village re-creates the sights, sounds and even the smells of Christmas past.

Many of the homes are decorated for the holidays just as their original occupants might have done them.

Traditional Yuletide music played softly in the manner of the periods adds to the charm of the Christmas flurry that greets the rooms, while some of the kitchens are filled with the aromas of Christmas cookery.

Past decorations have ranged from the simplicity of the 17th-century Cotswold Cottage with its garlands of boxwood and the yule log at the wellhead outside the door to the Victorian Wright Brothers' Home with its sprigs of holly, early Christmas cards and its full-length trees colorfully lighted with examples of some of the first electric Christmas lights.

Careful research assures the authenticity of all the decorations.

In the Webster House, for instance, where Noah Webster compiled the first American dictionary, the cedar roping, poinsettias, and candles in raw potato holders at the windows are described in Mrs. Webster's diary and letters.

In this way families visiting Greenfield Village are transported to centuries past when Christmas was not merely a jolly Santa Claus, but a very special state of being.

On their tour, they encounter many traditions of bygone holidays. The spicy aroma of mince-cake cooking in the kitchen.

Continued on Page 15

EXTRA DIMENSIONS

Make This
A BIG, BEAUTIFUL CHRISTMAS

BUY 1 BLOUSE
At regular price get the second blouse of equal or lesser value at
1/2 PRICE
Sizes 38-52

BUY 1 PAIR SLACKS
At regular price get the second pair of equal or lesser value at
1/2 PRICE
Sizes 32-48

EXTRA DIMENSIONS

8156 Cooley Lake Rd.
Union Lake
360-0036

M-F: 10-8
Sat: 10-5
Sun: 11-4

SALE ENDS DEC. 6, 1980

The KOHLER Super Bath
A FAMILY GIFT THAT LASTS FOR YEARS

The Robert L. Lussenden Company
COMPLETE CUSTOM KITCHEN & BATH DESIGNING
YOUR RELIABLE LOCAL REPAIR & REMODELING CONTRACTOR

2775 Haggerty Road • Walled Lake, MI
30740 W. 12 Mile Road • Farmington Hills, MI

(313)669-2020 (313)626-1808

FREE ESTIMATES

CLOCKS-CLOCKS-CLOCKS
Hundreds of clocks in stock
Plenty of time for Delivery before Christmas

Grandfathers include: Delivery, Set-Up and 2 Years Warranty.

15 to 30% off on Grandfather Clocks

Brand Names Such as
• COLONIAL • BULOVA • TREND
• HOWARD MILLER • NEW ENGLAND • HERCHEDE

Northville Watch & Clock Shop
We specialize in the sale & repair of antique watches and clocks

132 W. Dunlap, Northville (1 blk. N. Main St.) 349-4938
Christmas Hours: Mon. Tues. Sat. 9-6 Wed. Thurs. Fri. 9-9 Sun. 12:30-5

Radio Shack
DEALER

AUTHORIZED TRS-80 DEALER

MODEL II
MODEL III

\$ FREE \$
*10.00 if we can't beat your best deal with copy of current ad

LARGEST SELECTION IN GENESEE Livingston and Oakland County COME ON IN, LOOK AROUND!

Fun & Brains
MATTTEL Intellivision™

TRI COUNTY ELECTRONICS
ACROSS FROM SEC. OF STATE
2 Blocks North of K-MART
629-5767

Kmart®

The Saving Place™

Christmas savings

Fri., Sat. sale

ALL STORES
CLOSED THURSDAY,
NOV. 27

Open Sunday 10 A.M. to 8 P.M.

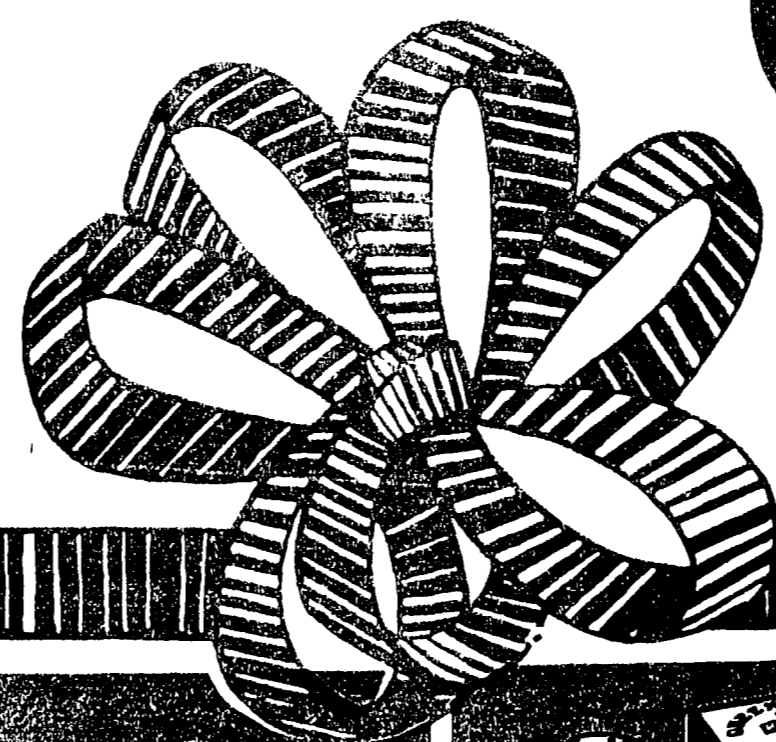

		Holiday STORE HOURS DAILY 9 a.m. to 10 p.m. SUNDAY 10 a.m. to 8 p.m.		

Copyright 1980 by Kmart® Corporation

We Honor

Open Daily 9-10;
Sundays 10-8

Kmart® MERCHANDISE POLICY
 Our firm intention is to have every advertised item in stock on our shelves. If an advertised item is not available for purchase due to any unforeseen reason, Kmart will issue a Rain Check on request for the merchandise (one item or reasonable family quantity) to be purchased at the sale price whenever available or will sell you a comparable quality item at a comparable reduction in price. Our policy is to give our customers satisfaction always.

48 Stores In The Greater Detroit Area To Serve You!

VISIT OUR 2 NEWEST LOCATIONS AT: 388 S. State St., Ann Arbor and 26100 Gratiot Ave., Roseville

Act now, avoid holiday frenzy

Does simply thinking about Christmas send you into a mild frenzy? Along with evoking pleasant visions of carolers, eggnog and happy family gatherings, the holiday season also evokes crowded stores, hectic shipping and last-minute preparations.

Single home newspaper readers can begin by lightly outlining an open-house plan for the week before Christmas. Prepare a hot concentrated dye solution (dissolve 1/2 cup of liquid dye or 1/4 cup of powder dye in 1 cup of very hot water (steeping hot —

Put your Christmas card and gift list together early to avoid any last-minute rush. Starting early allows you plenty of time to make your own Christmas cards. All you need is a pen, a stamp, a few sheets of paper, a thin artist's brush and a bottle or box of household dye.

Begin by lightly outlining an open-house plan for the week before Christmas. Prepare a hot concentrated dye solution (dissolve 1/2 cup of liquid dye or 1/4 cup of powder dye in 1 cup of very hot water (steeping hot —

Scarlet flower Mexican delight

Continued from Page 9

weds into the beautiful scarlet flower we know so well.

Today, poinsettias are imported from Central America and grown in a certain plant house to keep the plant from setting its buds too early.

Once all of the brilliant leaves have faded, the plant should be trimmed back to the main stem. It will flourish outdoors in the summer in most parts of the country, becoming more hearty as the weeks of the first week of October to the second week of November, poinsettias require equal amounts of brilliant red and white flowers.

THIS HANDSOME WEATHER STATION

It not only tells you the weather, it also tells you the time, the date, the month, the day of the week, the month, the day of the week, the month, the day of the week.

HOK'S JEWELRY

3475 W. MICHIGAN AVE. (at 12 Mile)
ANN ARBOR, MI 48106
348-1040

simmering, and dip brush into your favorite color.

After removing any excess dye from the brush, paint the eye onto the paper with light, feathered strokes. The edges toward the center of the open area. After your design dries, you can add details with colored pencils, India ink or paper airplanes such as gold stars.

Making your own colorful seasonal greetings is easy and economical, and it's a great gift for the holidays. Also, remember to mail your cards early so they aren't delayed in the heavy holiday mail crush.

—Check your Christmas ornaments before the holiday arrives.

THIS HANDSOME WEATHER STATION

It not only tells you the weather, it also tells you the time, the date, the month, the day of the week, the month, the day of the week.

HOK'S JEWELRY

3475 W. MICHIGAN AVE. (at 12 Mile)
ANN ARBOR, MI 48106
348-1040

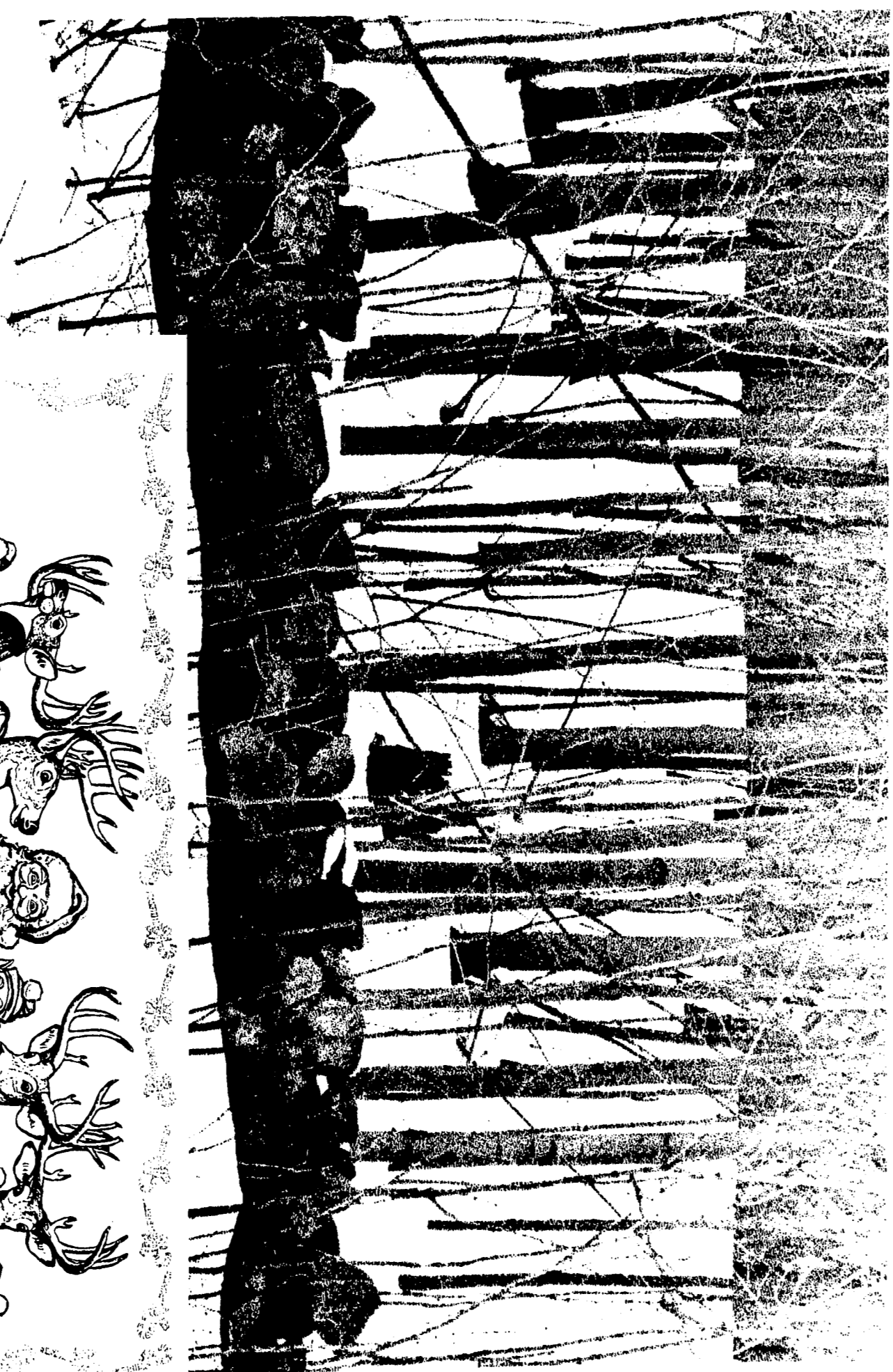

How beautiful it was, falling so silently, all day long, all night long, on the mountains, on the meadows, on the roofs of the living, on the graves of the dead —

Longfellow

WATKINS FLOWERS PRESENTS

November 30th Sunday 10 a.m. - 11 1/2 p.m.

Preview Flower Arrangements, Gift Ideas and Home Decorating DOOR PRIZES REFRESHMENTS

Bring in this ad for 10% OFF on any item in the store Sunday Only—11/30/80

624-4507 "in the of 'Wedded Lake'" 640 N. Pontiac Trail-Wedded Lake

BIG AND LITTLE KIDS CLOTHES

41684 W. TEN MILE NOVI-TEN PLAZA

PRE-CHRISTMAS SALE!

20% OFF EVERYTHING IN THE STORE (MINIMUM OF \$5)

ALL AMERICAN-MADE MERCHANDISE
HER MAJESTY—LEROI—BRITANNIA
ABEL—POLLY FLINDERS—DANNA
349-1626 —FREE GIFT WRAPPING—

Christmas Gift Suggestions

... for shower & bath

from our fancy bath boutique

- Shower Curtains
- Bath Towels
- Bath Mats
- Bath Linens
- Bath Socks
- Bath Slippers
- Bath Brushes
- Bath Sponges
- Bath Candles
- Bath Trays
- Bath Stools
- Bath Benches
- Bath Seats
- Bath Rugs
- Bath Mats
- Bath Slippers
- Bath Brushes
- Bath Sponges
- Bath Candles
- Bath Trays
- Bath Stools
- Bath Benches
- Bath Seats
- Bath Rugs

Long's fancy bath boutique

190 E. MAIN ST., NORTHVILLE 349-0373
Hours Mon.-Thurs. 9-5:30 Fri. 9-9 Sat. 9-5
Special Sunday Hours 12-5 (Dec. 7 thru Dec. 21)

A CURE FOR THE COMMON COLD!

CHRISTMAS UNDER THE SUN

Call Us Now.

PHILLIPS TRAVEL SERVICE

ECONOMY TRAVEL STARTS LOCALLY

Office Open Monday-Friday, 9 am to 5:30 pm
Evenings by Appointment
CALL 437-1733

COE'S MEN'S WEAR

In town shopping convenience

Sweaters by Jantzen & Catalina
Farrah Slacks & Jeans
Levi Jeans
Van Heusen Dress & Sport Shirts
Woodrich Catalina Jackets

Our own tailor shop

Hours: Mon-Fri 9:00 a.m.-8:00 p.m.
Sat 9:00-5:00

437-2004

116 East Lake South Lyon



**Save
28% to 30%
Gift Her With
Sportswear**

Our Reg. 12.96 - Save 3.96

\$9

Misses' Brushed Knits
Wonderful tops for runway success! Soft, warm brushed acrylic in styles shown and even more. Galaxy colors.

\$10 TO \$12

Our 13.96-16.96 - Save 3.96-4.96

\$10 TO \$12

Misses' Trouser Pants
Trousers are here! With the same fine tailoring as menswear. Polyester/cotton or blends. Great styles, colors.

Pants Style Representative Of Group

\$10 TO \$12

**Save
12% to 22%
Full Figure
Fashions**

Our 20.27-22.94

17.88

Festive 3-pc. Pantsuits
Tailored blouse, linen-look vest, pull-on pants. Polyester. 14 1/2-24 1/2. Save!

Our 11.96-12.96

9.44

Border Print Tunic Tops
Holiday minded tops splashed with smart patterns. Polyester. 14 1/2-24 1/2.

Our 7.96-8.96

6.94

Waist-sized Pull-on Pants
Your wardrobe basic in trim fitting polyester. Season's colors. 32-38.



\$15 Our Reg. 18.96 Save 3.96

Full Figure Robes With Arnel®
Fleece robes of Celanese® Arnel® triacetate/nylon in a host of styles with feminine trims. Rainbow colors. 38-44. Reg. TM of the Celanese Corp.

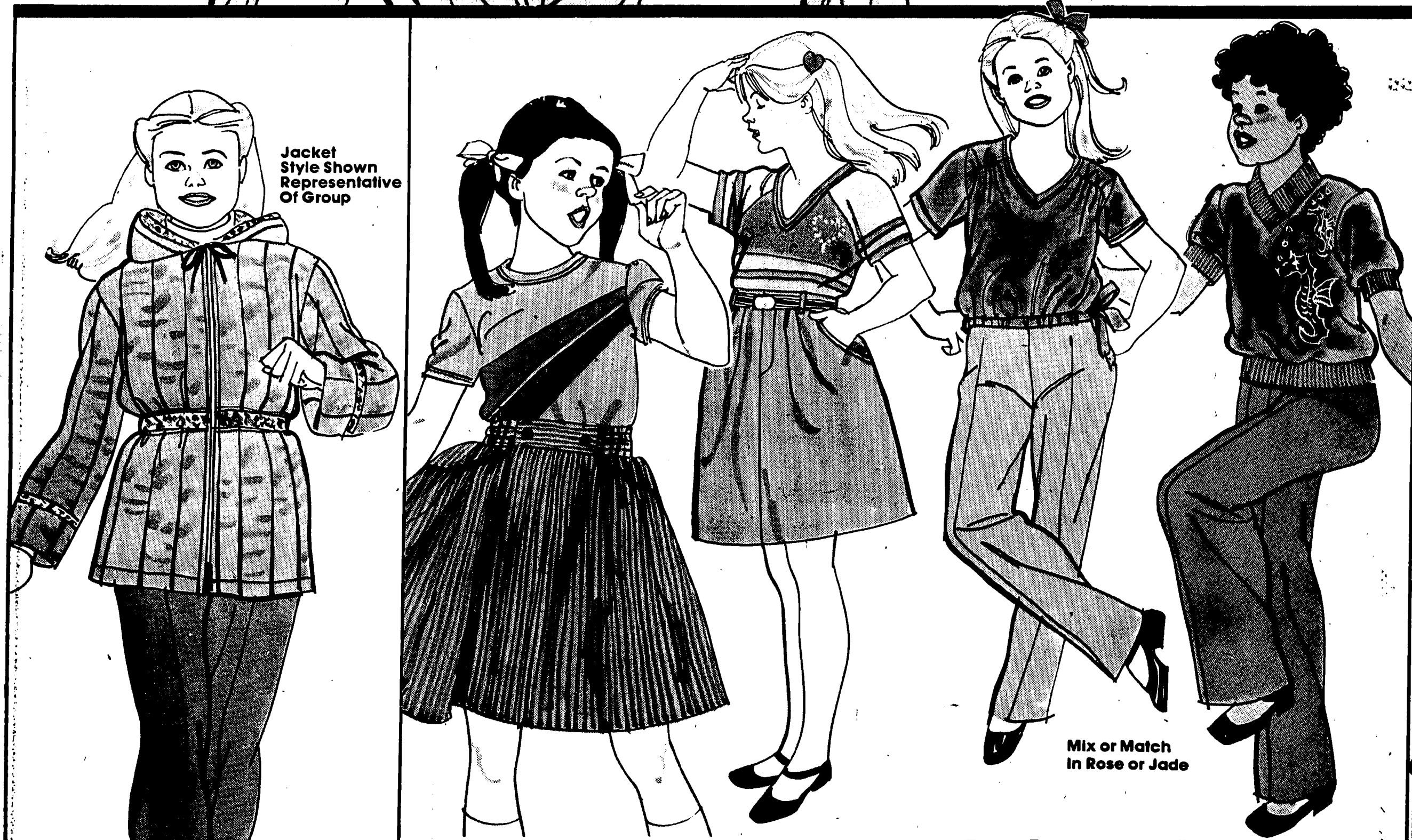

Jacket Style Shown Representative Of Group

Mix or Match In Rose or Jade

Our 12.47-32.96 Save 2.47-7.96

\$10 To \$24

Girls' Winter Jackets
Top of the season pick! Styles in polyester/cotton blends or nylon. Colors, styles galore. 4-14.

Girls' Holiday Matchmates

Our Reg. 5.57-10.96

4.66 To 8.88

The gang's all here in match-ups! Plush triacetate/nylon panne' or polyester cotton twills. Sizes 7-14.
• Our 10.96 Twill Fash • Our 6.96-7.96 Panna' Ion Pants 8.88 Tops 5.88-6.88
• Our 8.57-8.96 Panna' • Our 5.57-5.96 Tops Skirts, 2 Styles 6.88 and Tee Shirts 4.66



Illustrated style in sizes 7-14 Only Style Shown Representative Of Group

Our 13.57-15.57 - Save 2.69-4.69

10.88

Girls' 2-pc. Skirt Sets
Holiday bright! Cotton print skirt, peppy polyester/cotton, lead-with-lace shirt. One of a group. Save!

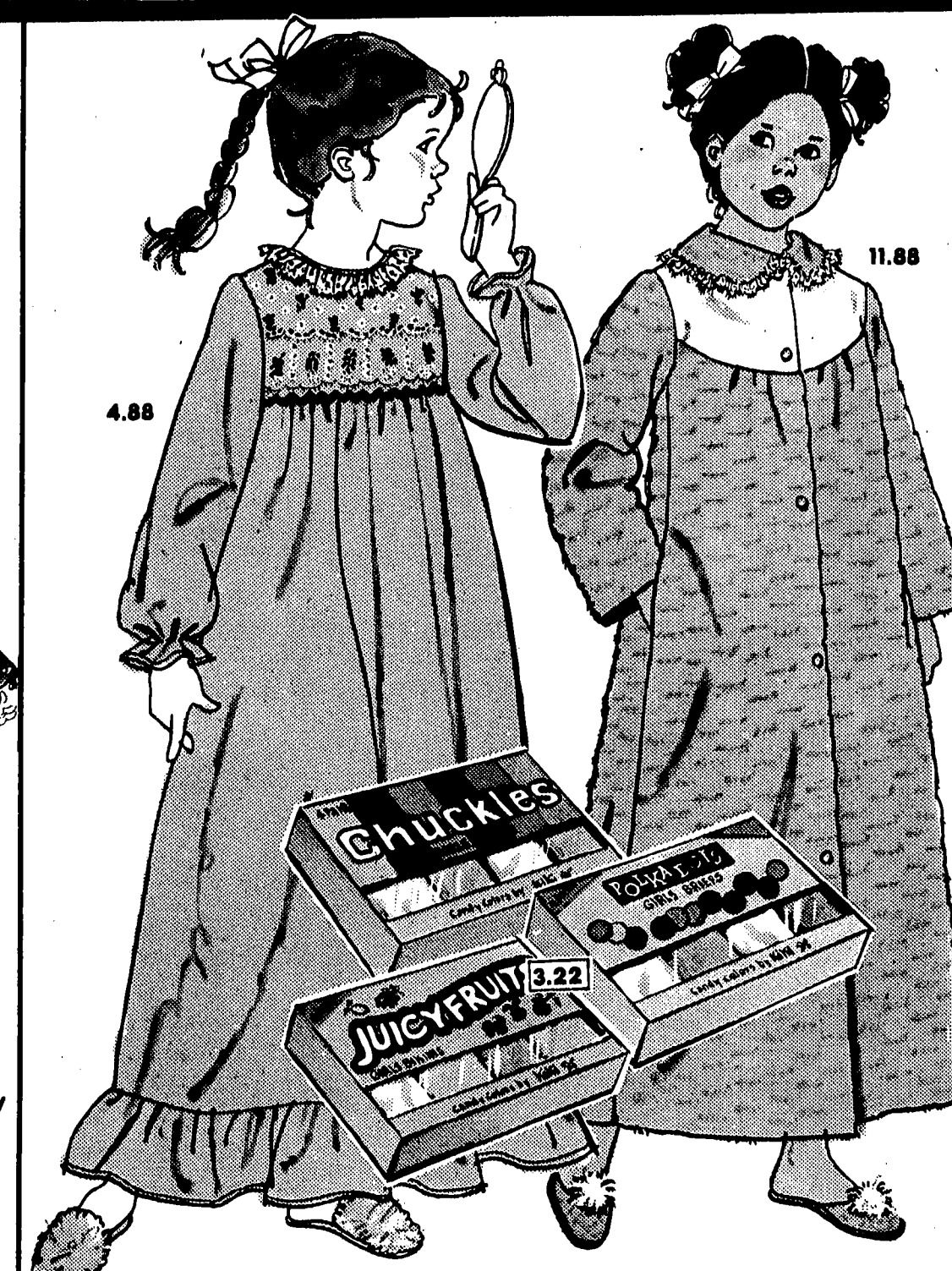

4.88

11.88

4.88 Our Reg. 5.96-6.96

Girls' Brushed Nighties
Snug, cozy polyester, 7-14. Our Reg. 4.67-4.6X 3.88

3.22 Our 3.96 4-pr. Box

"Candy Box" Panties
Bikinis/briefs. Acetate/nylon. Girls' 4 to 14.

Save 3.08-4.08

11.88

Girls' Lush Pile Robes
Our 14.96-15.96 robe in button-front styles. Cozy modacrylic/nylon deep pile. Delightful colors. 4-14.



5.97 Your Choice Our Reg. 7.97

Holiday Handbag Sale
Smart canvas or vinyl bags in top handle or shoulder strap styles. Our 6.97-8.97 Handbags \$2 OFF

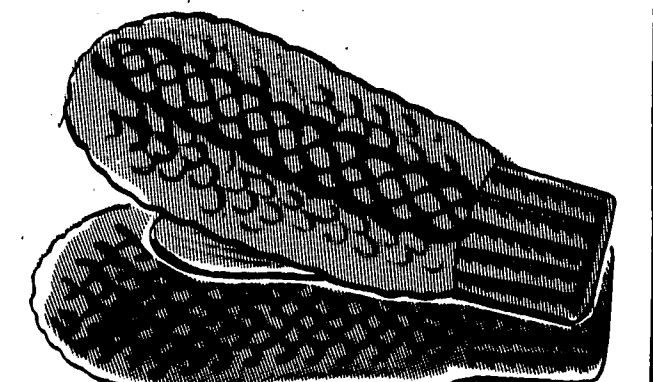

1.97 Pair Our Reg. 2.97

Misses' Acrylic Mittens
Great bulky knits with snug inner knit lining. Patterns or solids.

Kmart
THE SAVING PLACE

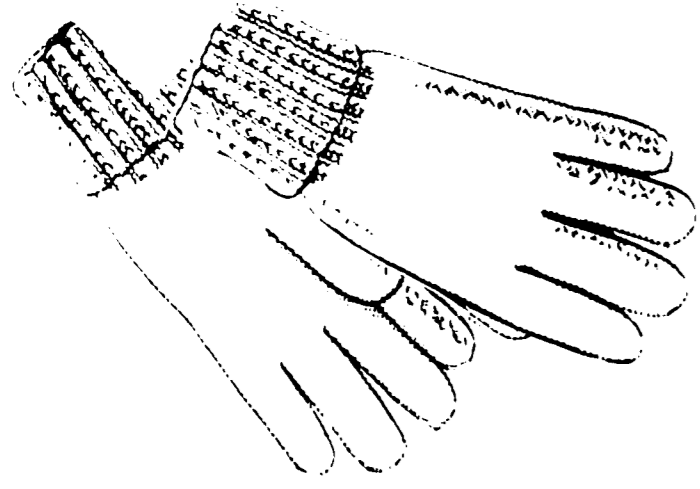

6.88

Men's Lined Gloves
Men's driving gloves of tan split cowhide lined with warm Sherpa® acrylic.



\$12

Pile-lined Denim Vest
Our Reg. 15.97 Warm Sherpa® acrylic-lined indigo blue cotton denim. Brass snap front. S-XL.

Save on gifts for men and boys!

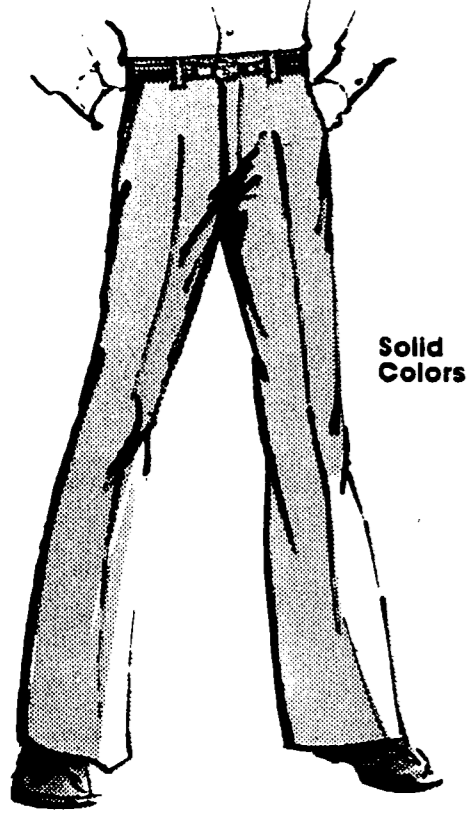

\$12 Our Reg. 14.96 Save 2.96
Belted Slacks for Men
Contrast-stripe belt adds a smart touch to these polyester hopsack slacks.



9.96 Our Reg. 11.96 Save \$2
Men's Corduroy Shirts
Great-feeling shirt of soft cotton corduroy. Button front. Solid colors.



9.96 Our Reg. 11.96 Save \$2
Plaid Flannel Shirts
Men's warm, heavyweight cotton flannel shirt in winter-brightening plaids.



\$13 Our Reg. 16.96 Save 3.97
Men's Terry Pullovers
Pull on the terry and take off the chill. Acrylic/polyester. Color choice.

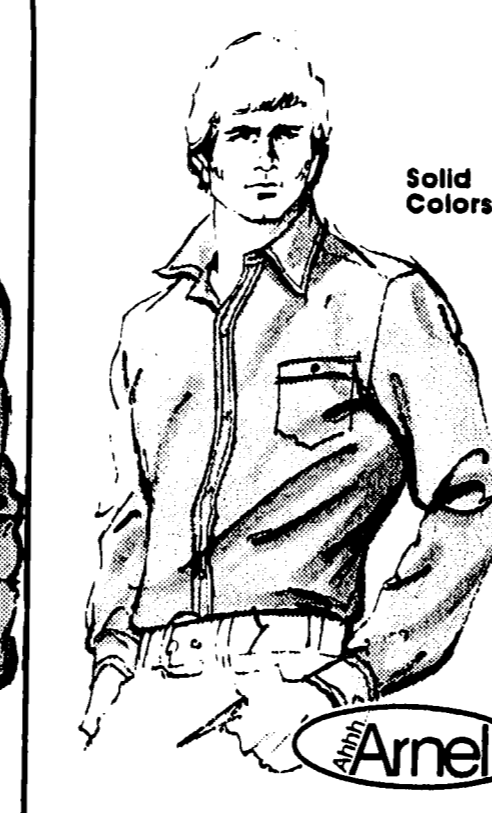

7.96 Our Reg. 9.96 Save \$2
'Super Suede' Sport Shirt
The look, the feel of fine suede. Celanese® Arnel® triacetate/cotton. Men's sizes. *Celanese Reg. TM



\$23 Our Reg. 27.97 Save 4.97
Men's Lined Coveralls
Polyester/cotton with polyurethane foam lining. Full cut. Elastic waist in back.

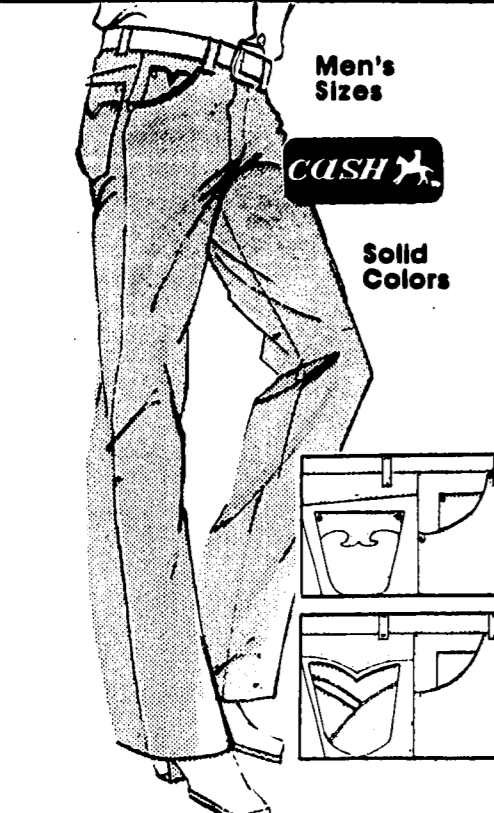

\$15.97 Our Reg. 17.97
Prewashed Denim Jeans
Fit-right, cotton denim fashion jeans. In flared-leg style. Men's sizes. Save.



8.77 Your Choice
Men's Jeans With Fortrel®
• Cotton/Celanese® Fortrel® polyester holds its shape wash after wash. Is tough as nails, you can count on it!
• Prewashed, brushed denim flares or regular denim flares. In blue.
• Bootcut denim in blue or boot-cut will jeans in solid colors.
Corduroy flared or straight-leg jeans in handsome solid colors. 8.77
Fortrel is a registered trademark of Fiber Industries subsidiary of Celanese Corp.

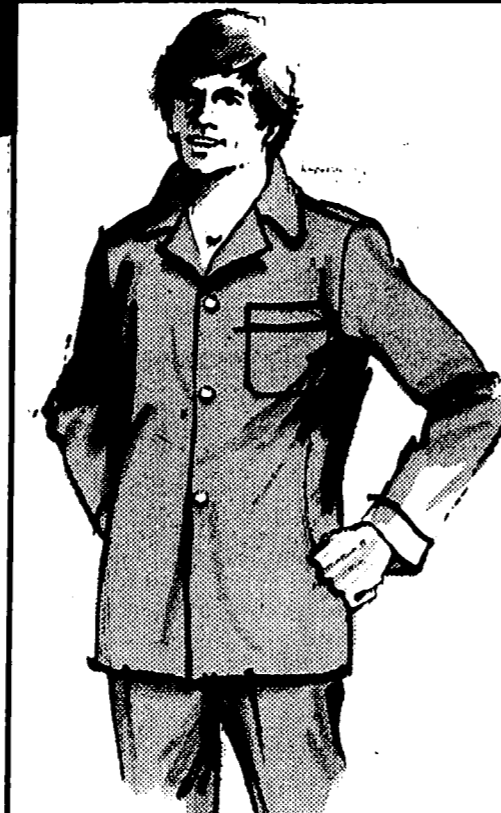

5.88 Our Reg. 8.57 Save 2.69
Men's Coat-style Pajamas
Wrinkle-resistant polyester/cotton in solid colors, prints. Button-front.

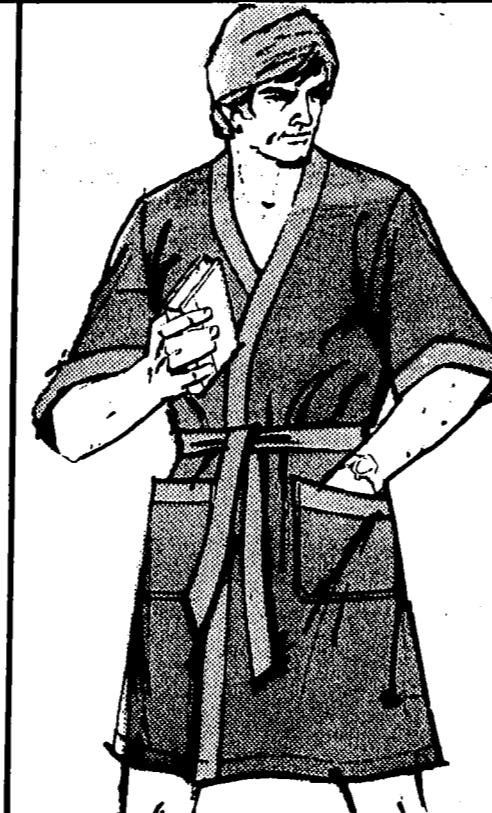

7.88 Our Reg. 10.97 Save 3.09
Men's Velour Karate Robe
Long-sleeved robe of polyester velour. In solid colors. One size fits all.



5.96 Our Reg. 7.96 Save \$2
Dress Shirts
Handsome shirts of polyester/cotton in stylish stripes. Save now!



5.97 Our Reg. 7.57
Western Shirt for Boys
Cowboy shirts of no-iron polyester/cotton. Embroidered and puff print.

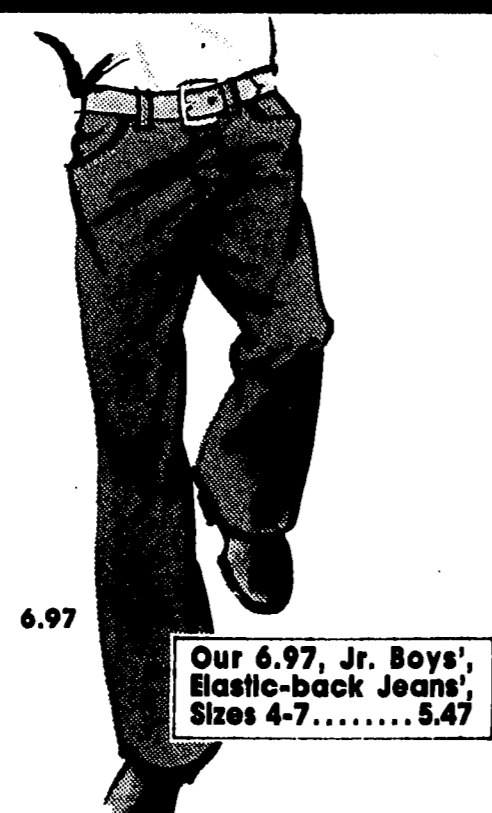

6.97 Our Reg. 8.97
Prewashed-Look Jeans
Bigger boys' blue polyester/cotton denim jeans with belt loops. Save now.



5.44 Our Reg. 6.97 Save!
Jr. Boys' Ski Pajamas
Fun to sleep in! Polyester/acrylic. Solid colors with trim numeral.



\$5 Our Reg. 6.96
Men's Sport Shirt, Dickie
Smart-looking duo! Polyester in great solid colors. Our 6.97, Boys' Sizes, 4, 47
*Padded cotton tannel with acrylic dicker

Quality Gifts at a Kmart price!

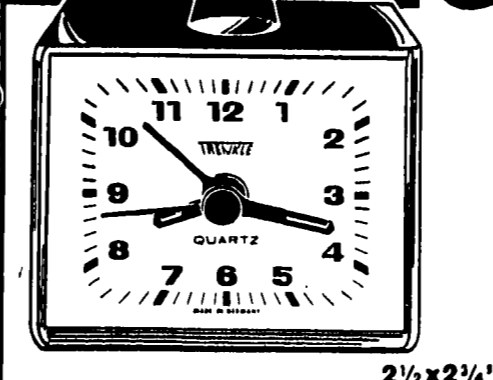

10.97 Our Reg. 14.97 Save \$4
Quartz Alarm Clocks
Battery-operated clocks. Sweep second hand. Luminous see-in-the-dark dots. *Not included.

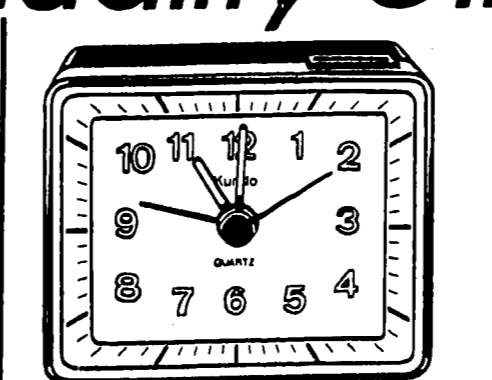

12.97 Our Reg. 16.97 Save \$4
Battery Alarm Clocks
Quartz accuracy in clocks with second hand and luminous dots on face, hands. *Not included.

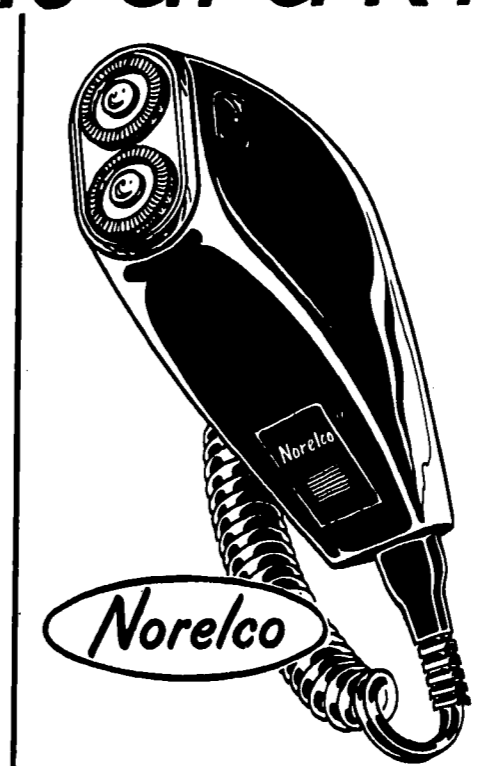

16.88 Sale Price
Doubleheader Shaver
Super microgroove shaver shaves you closer. With 24 self-sharpening blades.



16.97 Our Reg. 21.97-22.97
Women's Digital Watch
5-function. Quartz accuracy by easy-to-read LCD. Case, plastic strap.

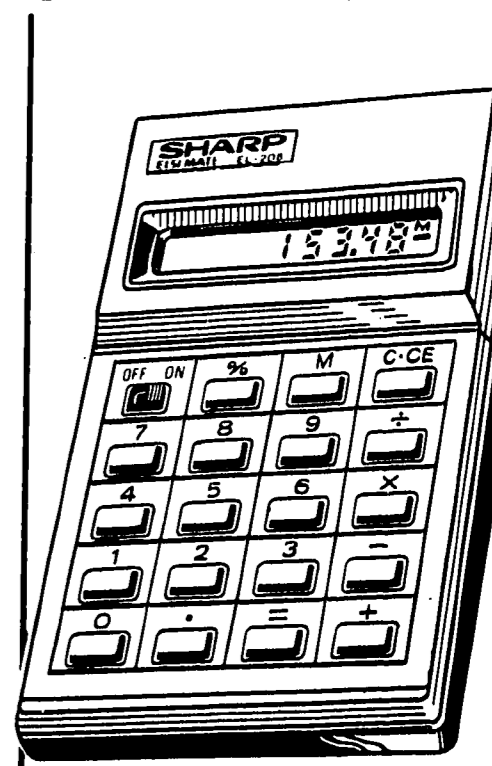

\$7 Our Reg. 8.97
Hand-Held Calculator
8-digit. With memory, percent key, double clear and clear-entry key. Compact. Battery not included.

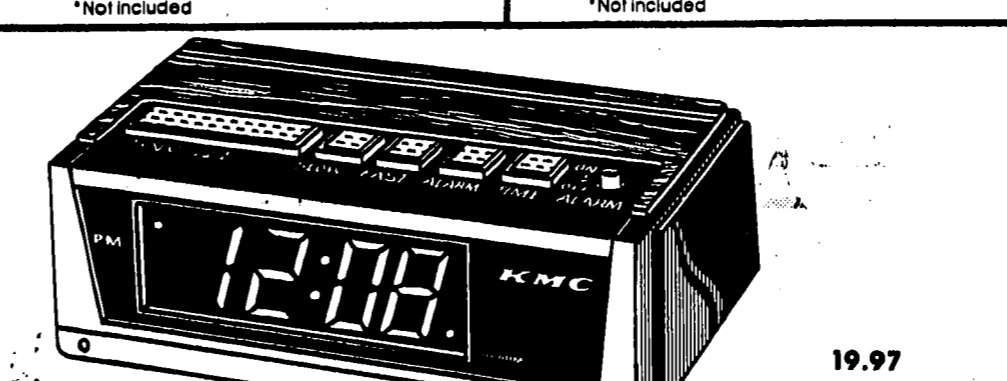

10.97 Our Reg. 15.88
Digital Alarm Clock
Red readout. Solid state 24-hr. alarm with touch and snooze. Time scanner.

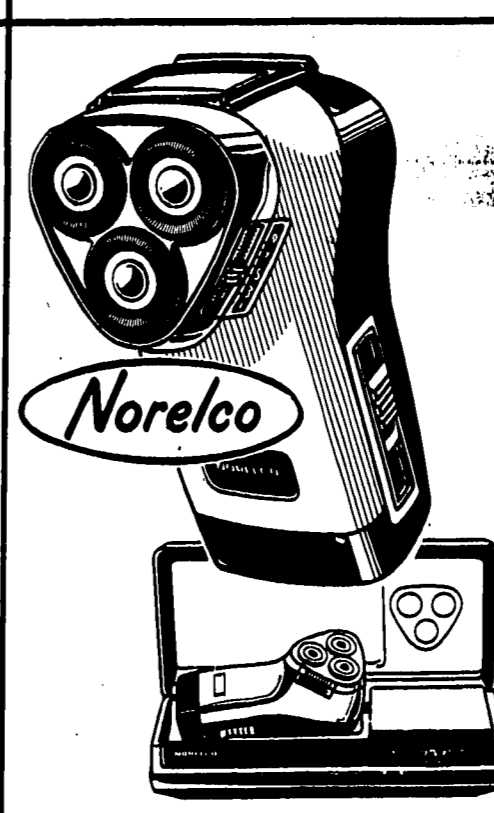

45.97 Sale Price
Rechargeable Shaver
Adjustable tripleheader, pop-out trimmer, voltage selector for world use.



16.88 Sale Price
Men's Remington® Shaver
Triple-head shaver for all types of beards. Smooth, comfortable, close shave.

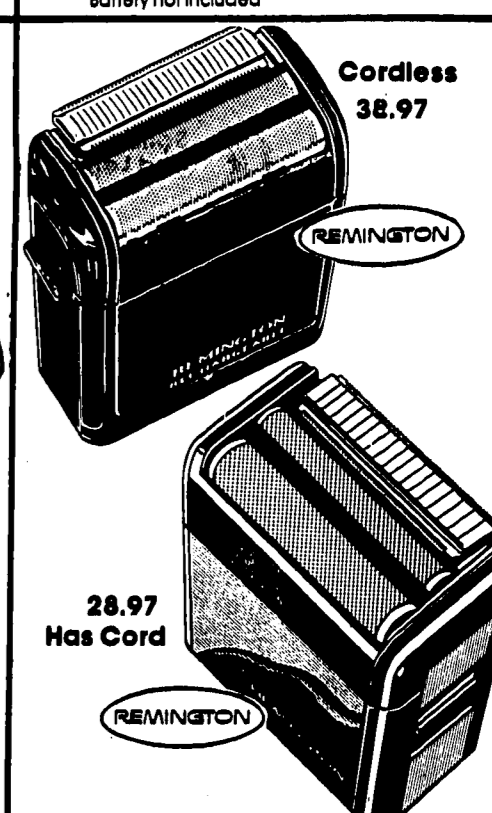

28.97 Sale Price
Men's Cord-style Shaver
Has flexible micro screen for extremely close shave. Our 41.88, Cordless... 38.97 *Rechargeable



\$9 Boys' Casual Boot
Brown vinyl upper boot with padded collar, steel shank on natural color rubber unit sole. Boys' sizes 12½-3.
\$14 Men's Rubber Pac Boot
Brown rubber lace up pac boot with warm felt liner, steel shank and barred heel. Men's sizes.
\$16 Women's Leather Boot
Tan leather upper 6" boot with vinyl collar, warm acrylic lining and natural color lug sole. Women's sizes.
\$10 Women's Leather Clog
Brown antiqued leather upper clog with padded collar on unit bottom. Women's sizes.
\$7 Women's Mid Heel Sandals
Available in black suede-like uppers or brown polyurethane uppers with mid height molded unit bottom. Women's sizes.

OPEN SUNDAY 10 A.M. TO 8 P.M.

Kmart 48 Stores In The Greater Detroit Area To Serve You!

DAILY 9-10 SUNDAY 10-8

4.97

- 1.4-oz. "Wind Song" Spray Cologne Super scent from Prince Matchabelli™.
- Fragrant Tabu™ Gift Set For Her 2-oz. eau de cologne, 3/4-oz. mist.
- 3.5-oz. "Emeraude" Spray Mist By Coty™ Leaves a lingering reminder of you. 1 1/2 oz.

1.5-oz. "Cachet" Spray Mist Cologne Individually different on each woman. 4.37



Your Choice
3.57

- 4-oz. "Charlie" Cologne Easy-on spray gift for her
- 6-oz. "Jontue" Cologne A refreshing spray scent. 1 1/2 oz.

4.66

- 1.25-oz. "Enjoli" Spray Charles Of The Ritz™ Cologne. 1 1/2 oz.

5.44

- 1.3-oz. "Chimere" Spray Prince Matchabelli™ cologne. 1 1/2 oz.

Quality Gifts at a Kmart Price!

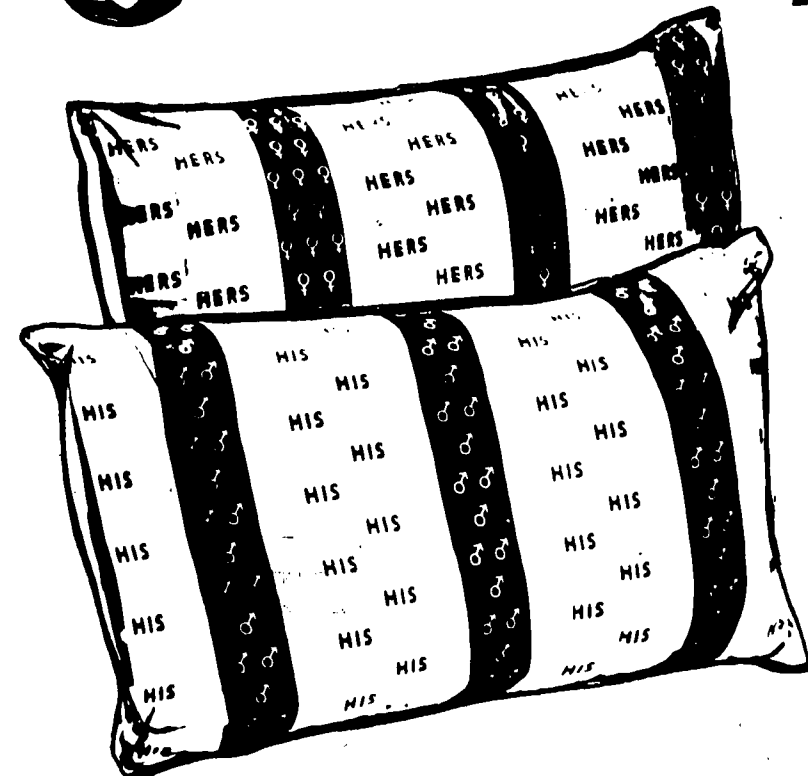

2 \$7

Our Reg. 4.97 Ea. Standard Size

"His And Hers" Sleeping Pillows With Polyester Fill Polyester/cotton ticking with "His" or "Hers" printing. Our 5.97 Queen, 2 for \$8. Our 6.97 King, 2 for \$10



Large 21" x 27"

29.97

Decorator Wall Clocks

Dramatic size gives a rich focal point to your walls. Silhouettes on glass reflect off colorful scenes. Accurate precision quartz movement. Operates on one battery. Contemporary frame styling helps enhance this eye-catching timepiece.

47.96

Unassembled In Carton

Choice Of Wall Units With Heritage Oak Finish Choose unit with sliding doors, open unit or unit with drop-lid desk. Each 28 1/2 x 11 1/2 x 7 1/4". Of particleboard.



Our Reg. 17.97-Save \$6

11.97

Convertible Slumber Bag For Teenagers

Open for a comforter, 68x90" finished size, close for sleeping bag.

Cotton Top 2-Lb. Polyester Fill

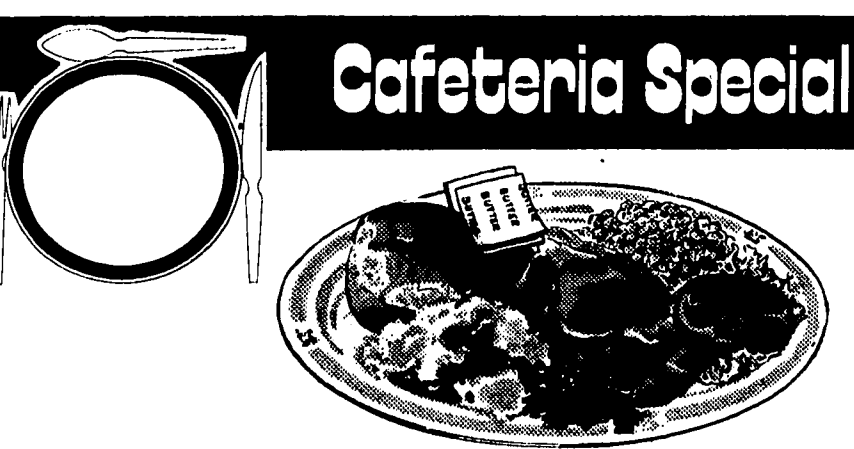

Cafeteria Special

1.88

Delicious Roast Beef Dinner With whipped potatoes, brown gravy, seasoned vegetable, roll 'n' butter.



Our Reg. 4.33

2.57

Jumbo Pack Of 12 Dish Cloths Waffle-weave cotton/polyester, each 13x15" size.



4.97

Your Choice Our Reg. 5.97

Infants' Gift Boxed Coverall or 2-pc. Suit with Shoes 1-pc. coverall for infants 0-6 mos. Or 2-pc. suit with matching shoes in sizes 0-3 mos. Both of soft acrylic.



DELI-SPECIAL Chopped Ham Sandwiches

4 For 1.17

3.47

Your Choice Our Reg. 3.97

Pin-up Wall Decorations For The Little Ones Favorite characters from children's stories, nursery rhymes and cartoons, in sturdy 1/4"-thick chipboard. Save.

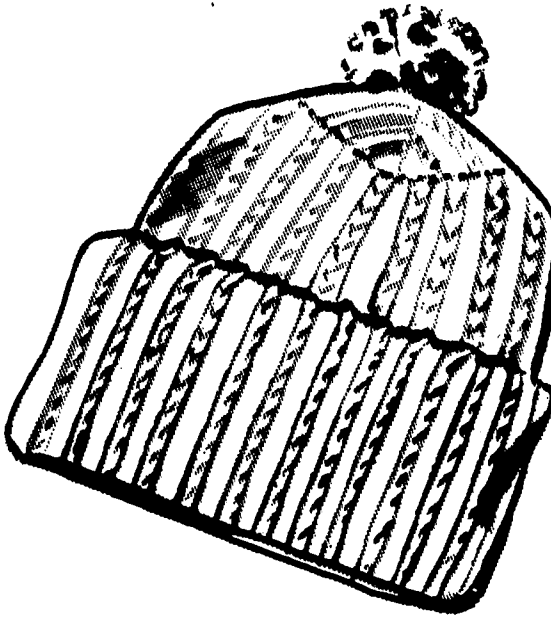

77¢

Our Reg. 1.17

Infants' Hockey Caps Of Orion™ Orion™ acrylic in solid colors or stripes. One size for all. DuPont Reg. TM.



TAPES **11.77**

ALBUMS **11.44**

Give the gift of music.



ALBUMS **6.44**

record & tape sale!

ALBUM **5.44**
TAPE **5.77**

ALBUM **9.44**
TAPE **9.77**

ALBUM **3.96**
TAPES **4.47**



ALBUMS **3.96**
TAPES **4.47**

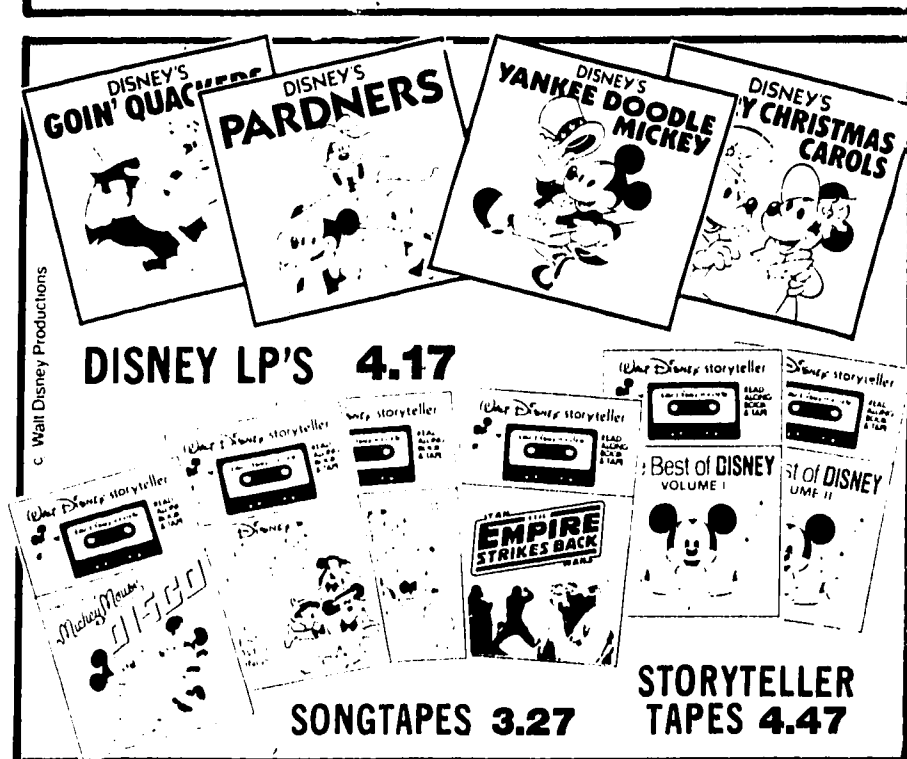

DISNEY LP'S **4.17**

SONGTAPES **3.27**

STORYTELLER TAPES **4.47**

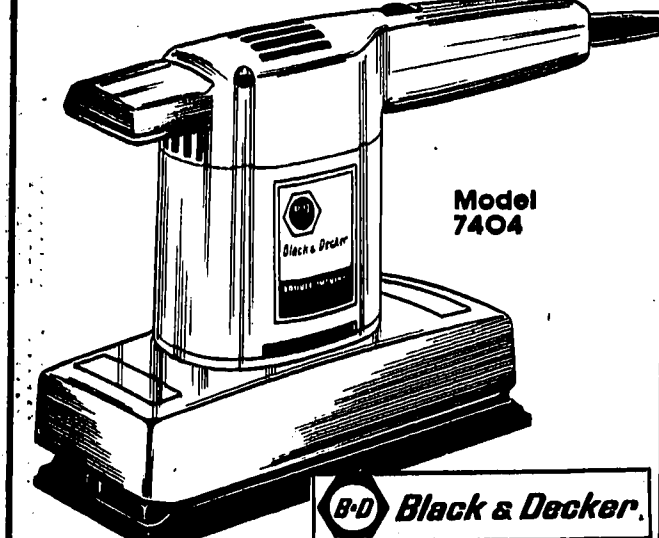

Model 7404

Black & Decker

15.97

10,000-OPM Finishing Sander Double-insulated, general-duty unit styled for 1-, 2-hand control.

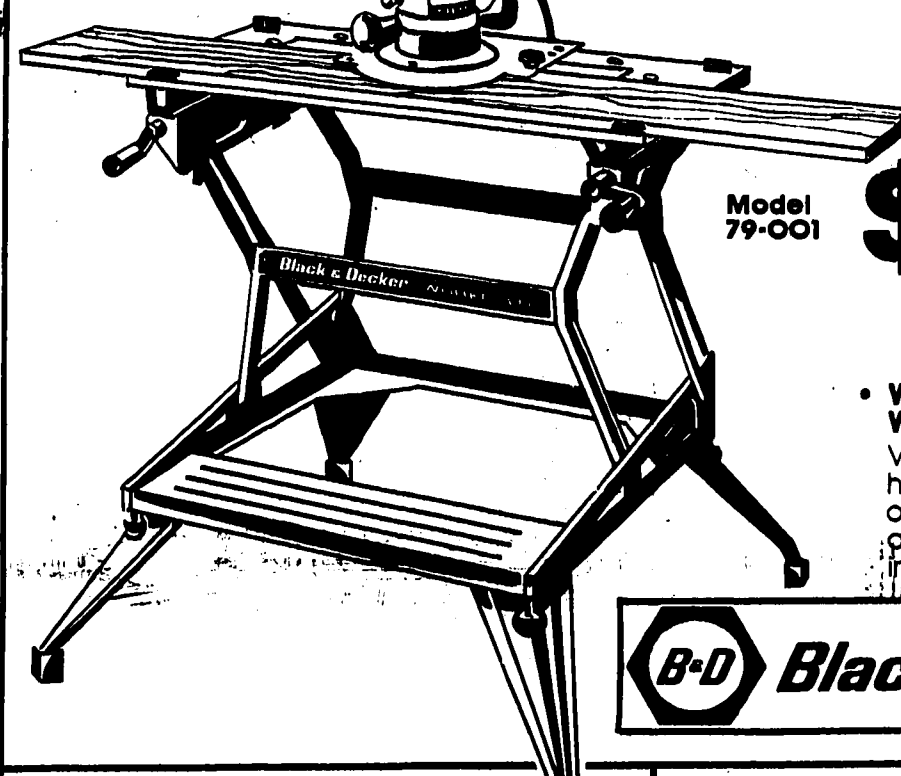

Model 79-001

Black & Decker

\$66

Workmate® Portable Work Center 'n' Vise Vise, workbench and saw-horse all-in-one. 29" jaws open to 5 1/4" wide. Adjustable foot leveling and working height. Folds away.

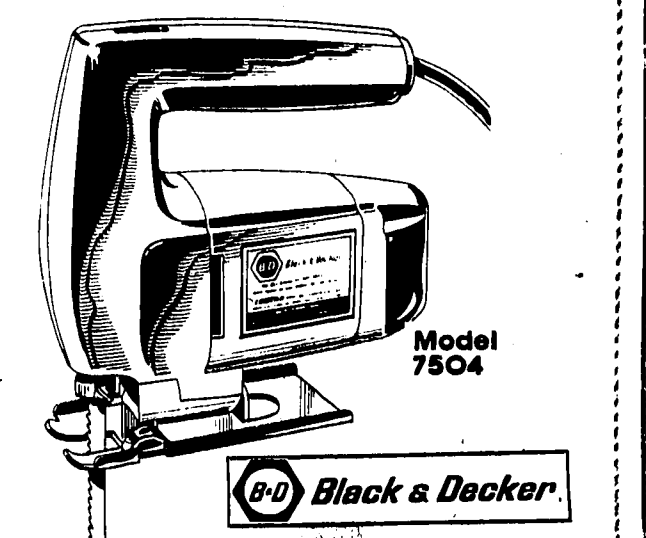

Model 7504

Black & Decker

9.97

Rugged General-purpose Jigsaw Makes straight, curved and scroll cuts. Double-insulated reliability. Shop now.

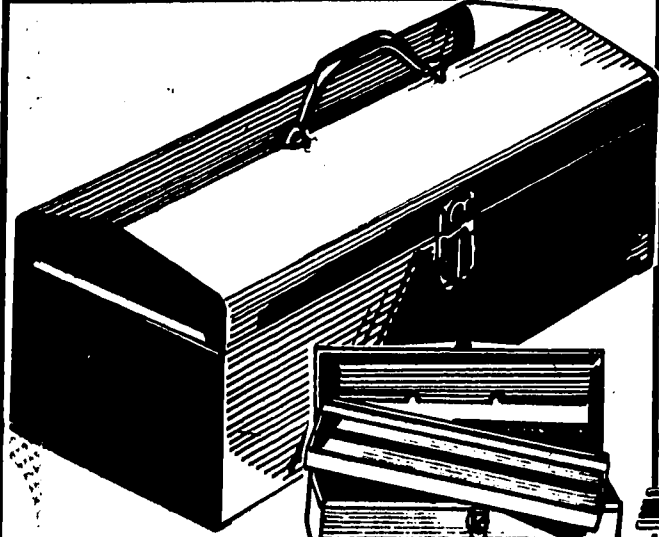

5.97

Our Reg. 10.77 Save 4.80

19x7 1/2 x 7" Metal Tool Box Lift-out tray design provides extra storage room. Save.

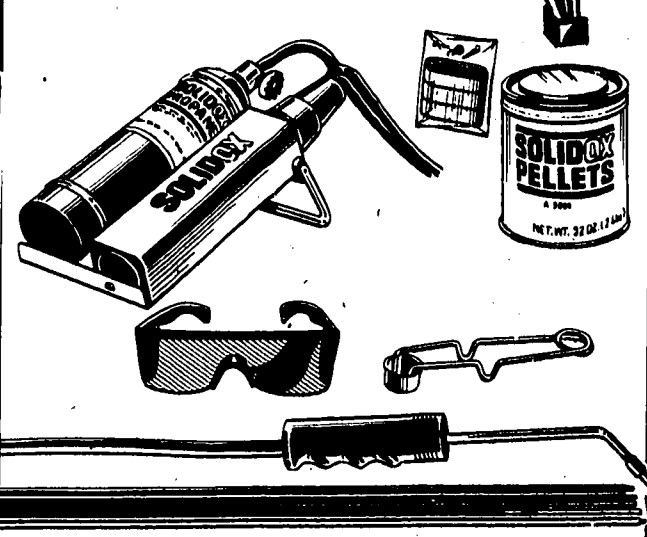

19.97

Solidox™ T5000 Brazing/Weld Kit Outfit includes torch, propane fuel, tips, pellets and more. Save now.

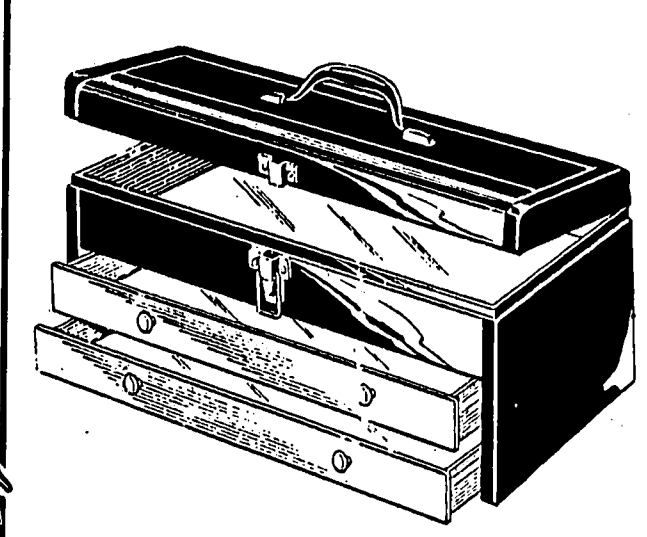

25.88

Our Reg. 34.88

Machinist's 2-drawer Chest Large enough for a bench chest, lightweight portability, too.

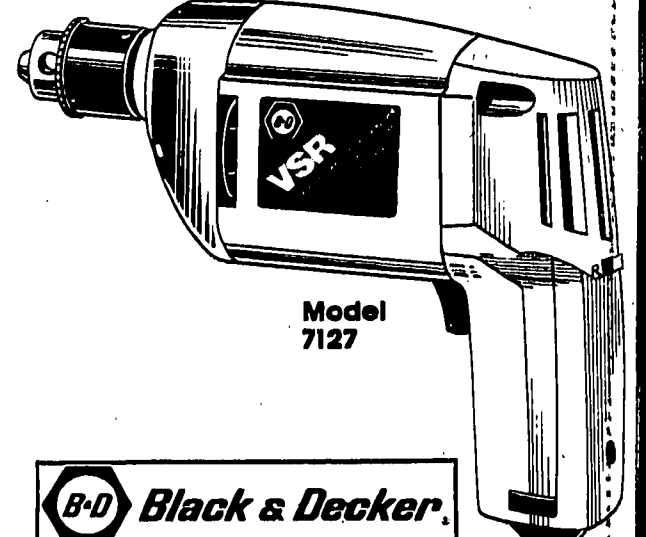

Model 7127

Black & Decker

16.88

3/4" Vort-speed Reversing Drill Power of 3/4"-drill, versatility of 1/4"-drill. Double insulated. Save.

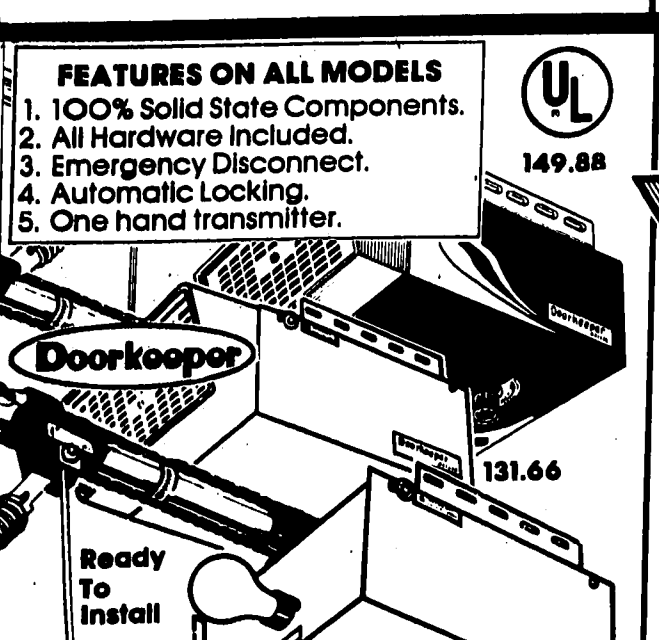

Open Garage Doors Up to 18' Wide. Everything Included For Installation

\$99

Electronic Garage Door Opener Standard model with 1/4-HP motor, chain-cable drive, 1 transmitter. Save. Deluxe 1/2-HP Model.....131.66 Digital 1/2-HP Model.....149.88

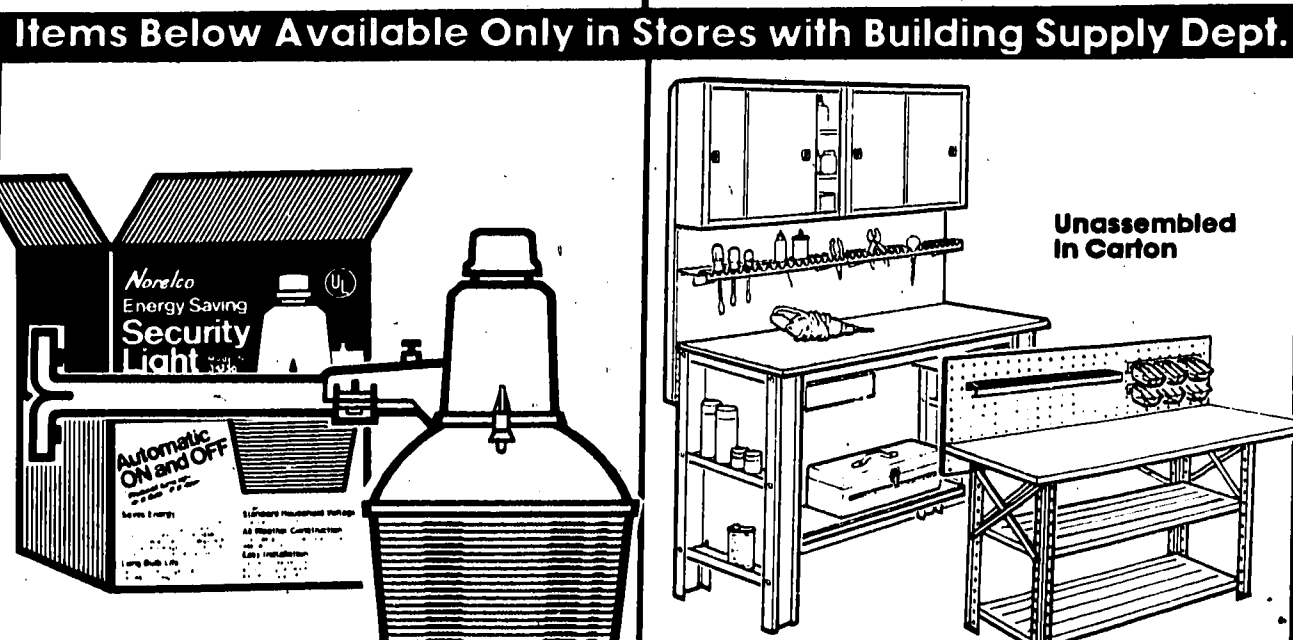

35.88

Mercury Vapor Security Yard Lamp Security lamp, with powerful 175-watt photoelectric bulb, provides light from dusk-to-dawn to protect your home. Ready to install. Save now.

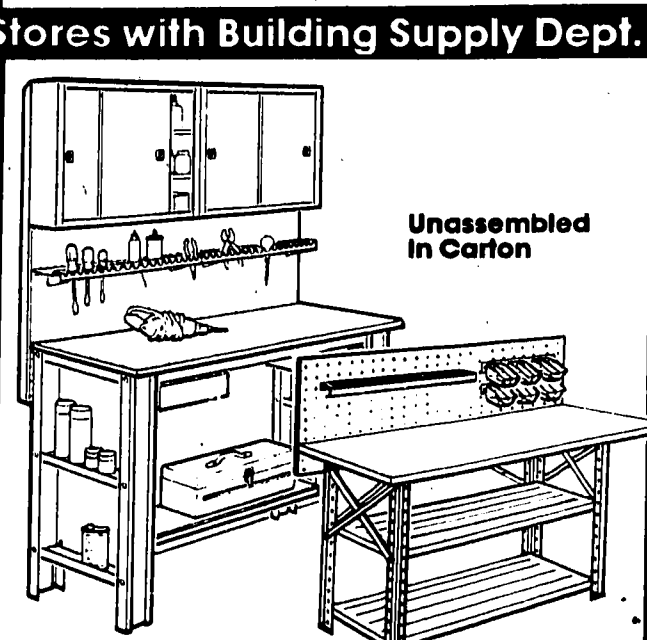

71.88

Deluxe 48x20x67" Work Center Cabinets, shelves, drawers, perforated panels, outlet.

22.88

Deluxe Work 'n' Hobby Center 3 shelves, tool rack, 6 plastic bins. 48x48x20".

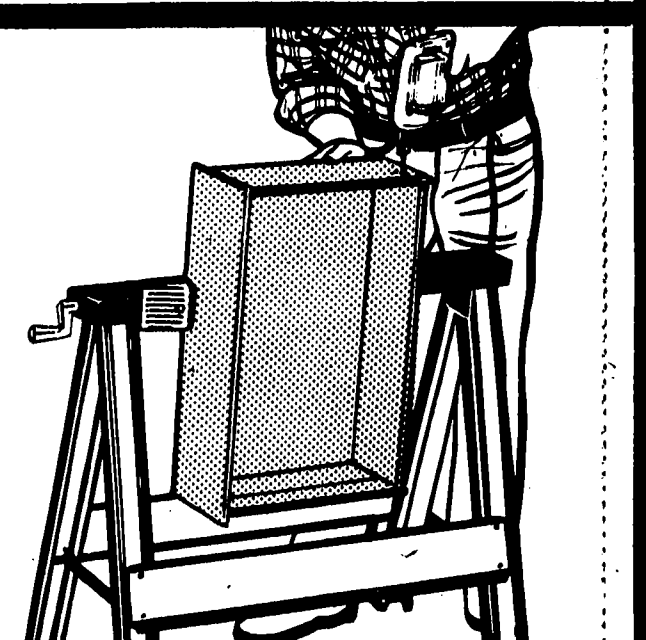

26.88

Work Grabber™ Vise 'n' Sawhorse Work up to 24" wide can be clamped between jaws. Removable swivel jaws can be used on top or either side. 30x32 1/2" unit is portable. Great savings.

Kmart

48 Stores In The Greater Detroit Area To Serve You!

DAILY 9-10 SUNDAY 10-8

Kmart

48 Stores In The Greater Detroit Area To Serve You!

DAILY 9-10 SUNDAY 10-8



Hasbro

GIFTS FOR KIDS OF ALL AGES

- a. Good Puppy™ 6.77
Heads command, chews biscuit
- b. Beware the Spider™ 7.86
A test of nerves, skill
- c. Skedoodle™ 7.86
Fascinating drawing machine
- d. Mousetrap™ 7.96
A challenging family game
- e. My Dog Has Fleas™ 7.96
Full of laughs

Quality Toys at a K mart price!

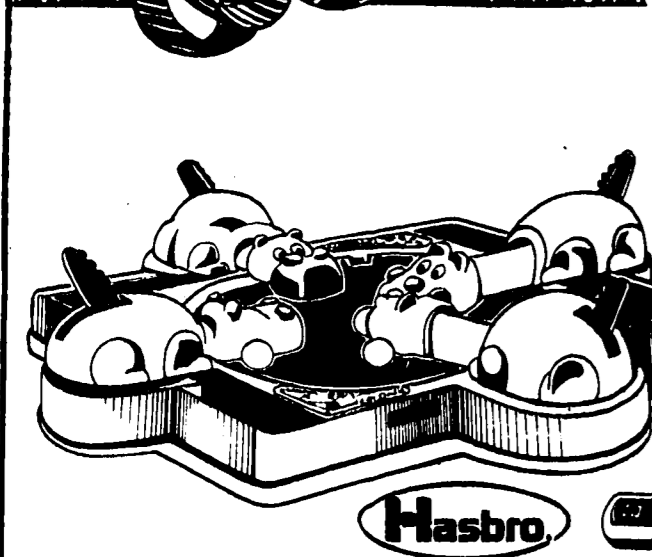

8.96

• **Hungry, Hungry Hippo™ Game**
Winner is player whose hippo snatches the most marbles. 2 to 4 players.



11.93

• **It's A Magical Musical Thing™**
Innovative toy electronically reproduces musical sounds. 21-in.

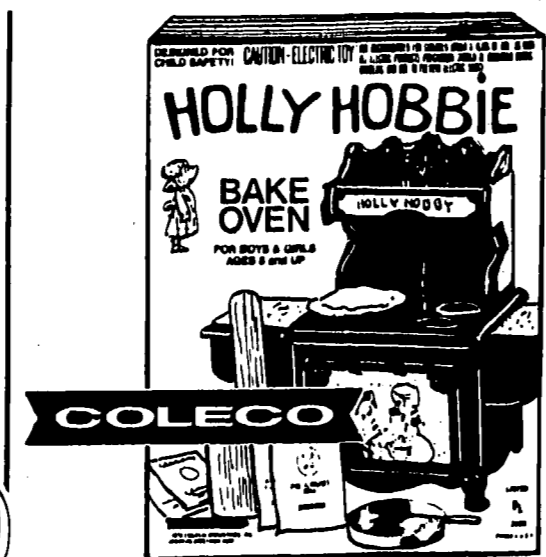

13.88

• **Holly Hobbie™ Bake Oven**
Old-fashioned style electric oven heats with one 100W light bulb. *Not included

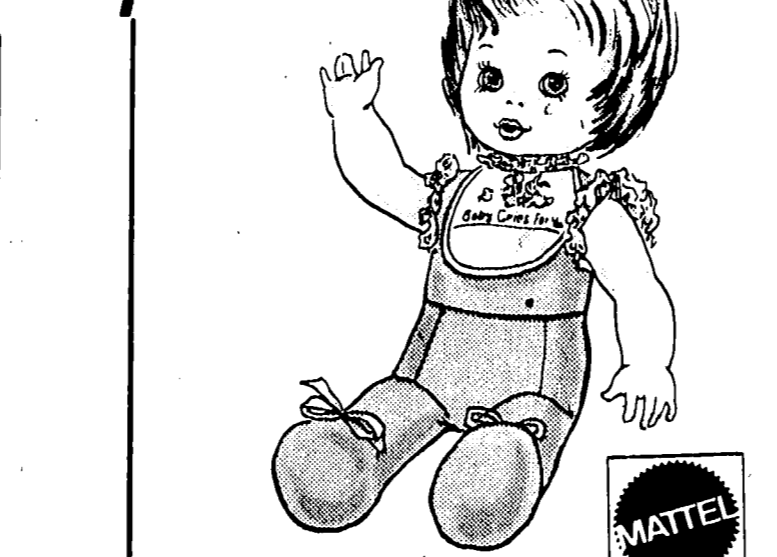

10.76 Limit 1

• **Baby Cries For You™ Doll**
Lovable baby doll waves goodbye, cries when attached string is pulled.



11.93

• **Candi Color 'N' Curl™ Make-up Center**
Complete make-up center with washable, non-toxic cosmetic colors.

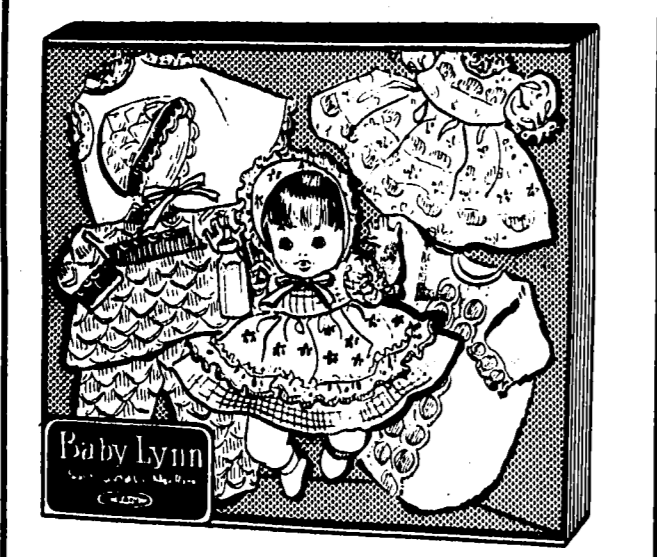

11.88

• **Baby Lynn™ Doll With Layette**
Soft and huggable 13" drink-and-wet doll with seven accessories.

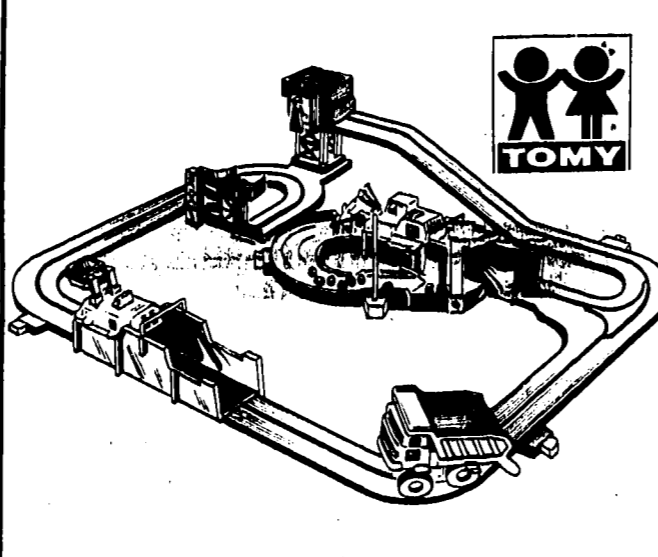

10.87

• **Big Loader™ Construction Set**
Keeps pre-schoolers busy as they load, fill, scoop, haul, dump.



14.76

• **Lovable Baby Cry & Dry™ Doll**
She wets, cries and kicks just like a real baby. Cuddly; 13 1/2". Save at K mart.

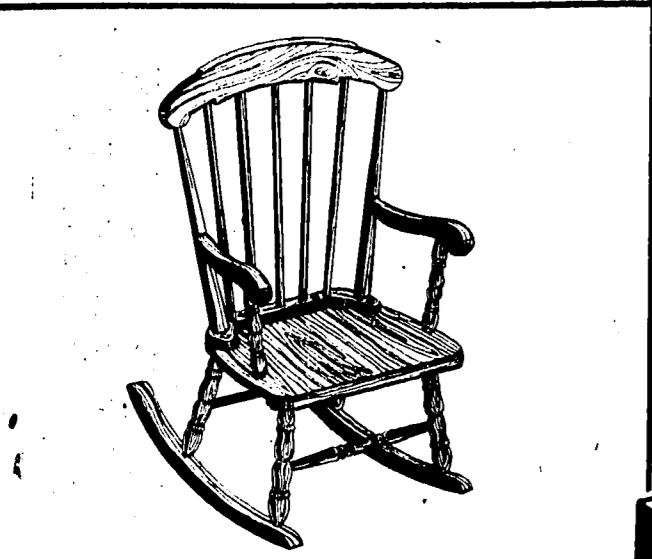

19.96

• **Old-fashioned Boston Rocker**
Every child loves a rocker. Well-made and durable, finished wood.

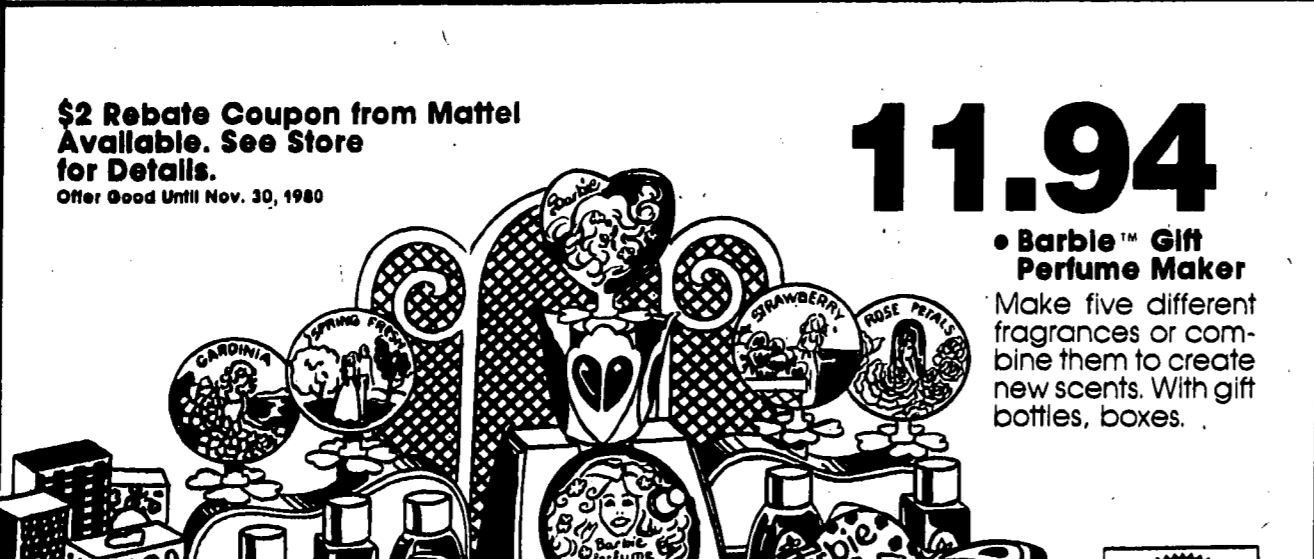

11.94

• **Barbie™ Gift Perfume Maker**
Make five different fragrances or combine them to create new scents. With gift bottles, boxes.



8.88 Ea.

• **Adorable 24-in. Missy Walker™**
So much fun to take for a walk. Long-rooted hair, moving eyes.

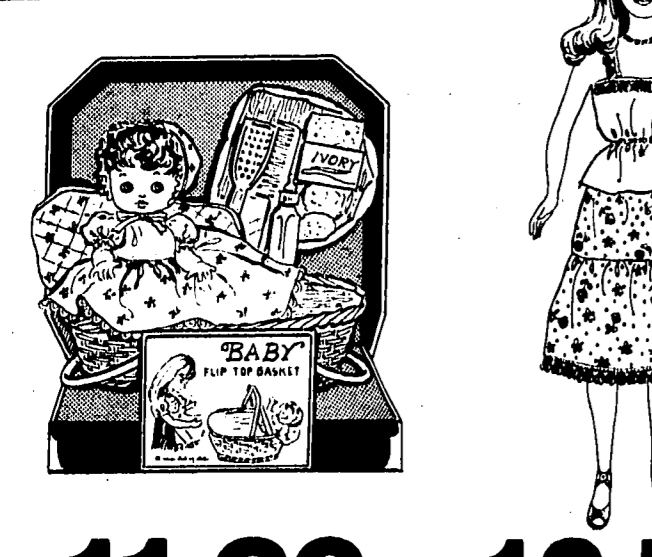

11.66

• **Baby Doll in Basket**
11" drink-and-wet doll; 10-pc. layette; basket.



12.76

• **Sparkle Candi™ Doll**
Change hair color, make-up, accessories.

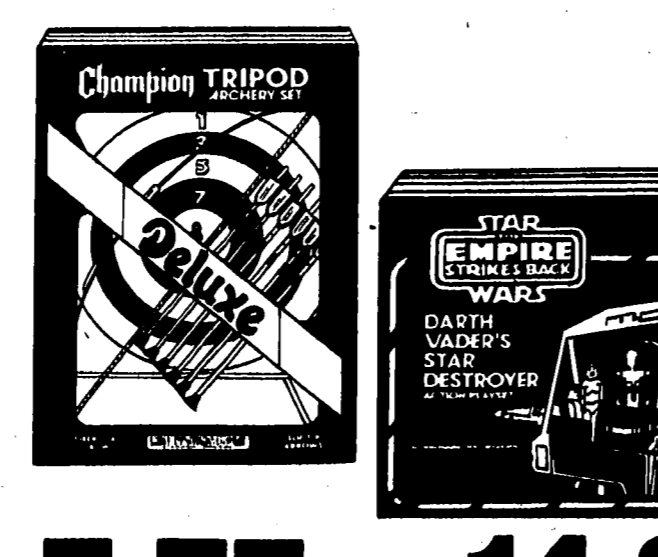

7.87

• **250-pc. Tinkertoy™**
Build and operate your own action toys. Fun!



7.77

• **Tripod Archery Set**
Official target, fiber-glass bow, 6 arrows.



14.88

• **Star Destroyer™ Set**
Darth Vader™ and the Force™ competition.



9.96

• **Turret Robot™ Playset**
Space action on Flath, the ice planet.

OPEN SUNDAY 10 A.M. TO 8 P.M.

PARKER GAMES

Popular Games For Family Fun

- a. Big Boggle™ 4.66
The hidden word game
- b. Mad Magazine Game™ 5.86
Crazy, mixed-up logic
- c. Sorry™ 5.86
Surprise moves build suspense
- d. Bonkers™ 5.86
Never the same game twice

Check K mart's Low Prices on Name Brand Games

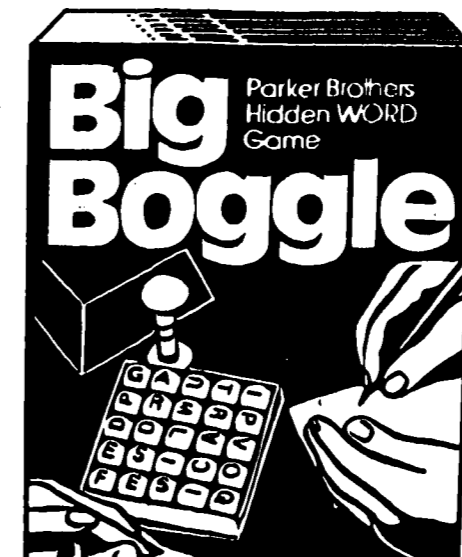

Christmas savings on brand name toys



11.93

• **Big Dig Construction Site™ For On-Job Fun**
Pre-schoolers learn by doing as they pour, dump, dig and drive around construction site. Truck included. Shop at K mart.



12.88

• **Sit 'n' Spin™ Driving Fun**
Just "turn" the wheel, and 'round you go. Works on any surface.

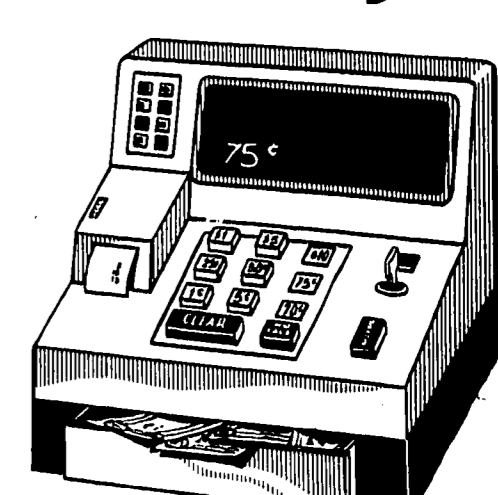

9.33

• **"Electronic" Cash Register**
Lighted "readout" window; 12 keys with buzzer sound, play money. Save now. Batteries not included.

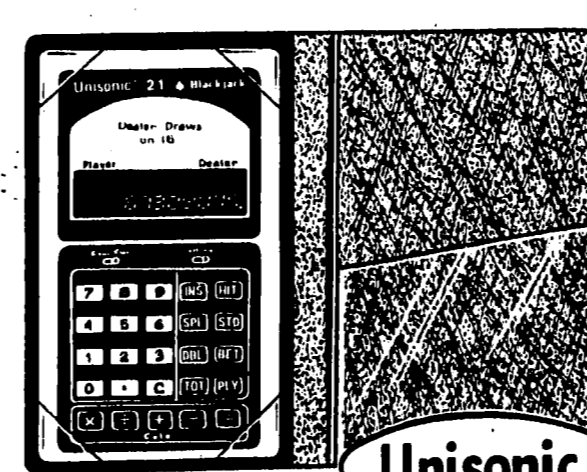

19.96

• **Electronic Blackjack Game**
Compact pocket-size blackjack game with 8-digit calculator. AC adaptor. Batteries not included.



24.96

• **Mini Desk Computer Blackjack**
Fun of Las Vegas, plus 8-digit calculator you can use separately. Shop now. Batteries not included.



29.96

• **Fabulous Fred™ Plays 10 Different Games**
Musical games, mind bender, Gasball, space attack, roulette, more. Fabulous Fred™ is loaded with fun. Save at K mart. Batteries not included.

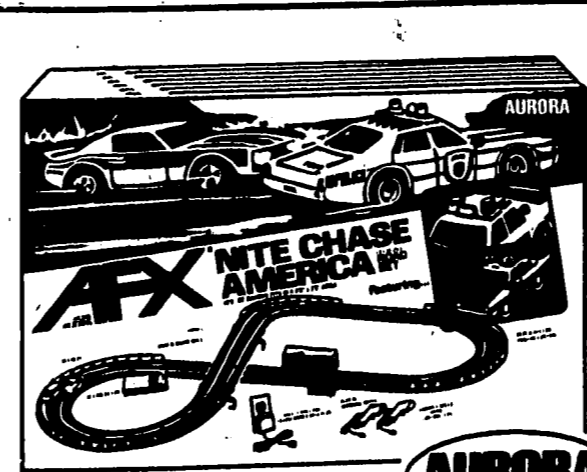

19.86

• **AFX™ Nite Chase™ Road Race Set**
Fast-racing action with police car, street car and 10 1/2" figure 8 track.



16.96

• **Hot Wheels™ Service Center**
Foldaway garage with dyno and car wash. Comes with Hot Bird™ car.

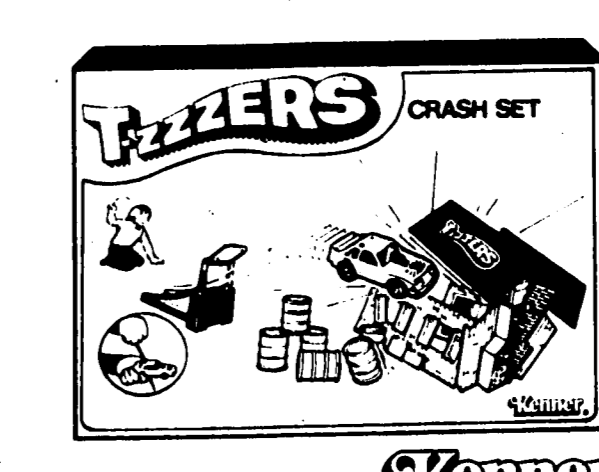

6.96

• **Fast-paced T-zzers Crash Set™**
Thrill-a-second action as special-styled stunt car jumps the ramp.



8.94

• **Lite Brite™ Glows in Color**
Create a picture with pegs and turn on light for dazzling display. Shop now. Battery not included.

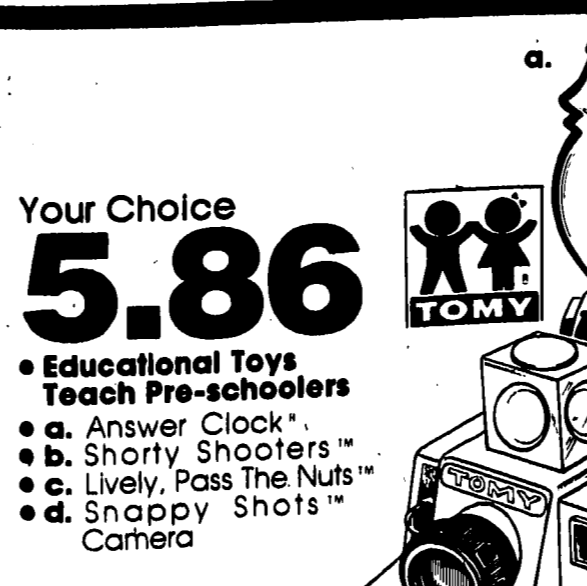

5.86

• **Educational Toys Teach Pre-schoolers**
a. Answer Clock™
b. Shorty Shooters™
c. Lively, Pass The Nuts™
d. Snappy Shots™ Camera

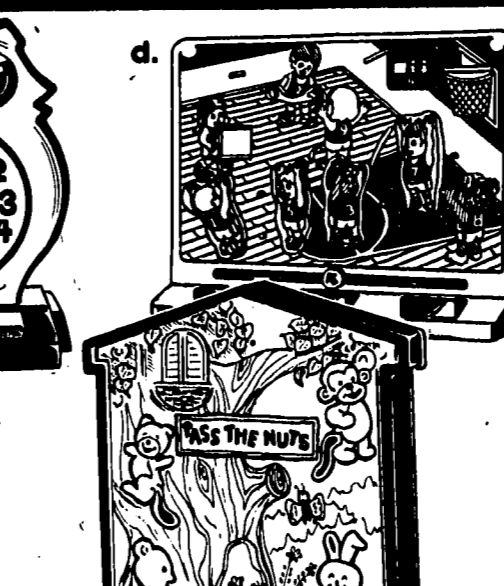

7.77

• **9-in. Powerizer™ Superhero™ Figures**
a. Hulk™ throws log
b. Spider-man™ climbs
c. Superman™ flies
d. Batman™ climbs
No batteries required

Kmart 48 Stores In The Greater Detroit Area To Serve You!

DAILY 9-10 SUNDAY 10-9

Your Choice

15.97

Appliances Make Welcome Gifts

a. 4-slice toaster with "Bread Brain" control
 b. AM/FM, AC/DC* full-circuitry portable radio
 c. Can opener/clock with magnetic lid-grabber
 d. Super Steam* "self-cleaning" steam/dry iron
 e. 1200 W Styler Dryer with styling attachments
*Batteries not included

Quality Gifts at a K mart price!

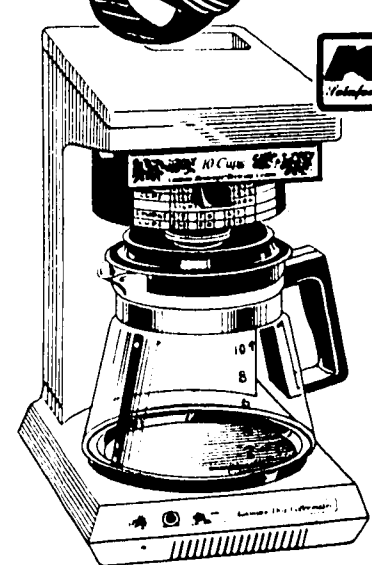

19.94
 10-Cup "That's Coffee"
 Automatic drip coffee-maker, brewing guide, snap-in lid. Also makes tea, soup, cocoa. Save now.

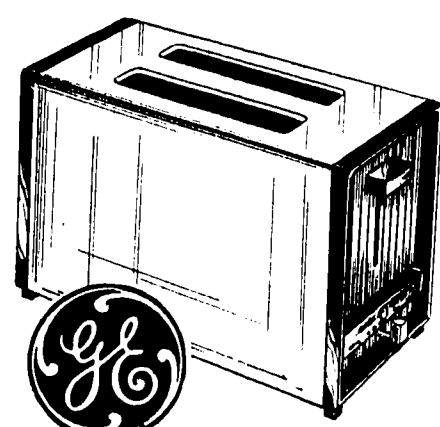

12.87
 2-Slice Pop-Up Toaster
 Automatic toast carriage, toast color selector, easy-clean hinged crumb tray.

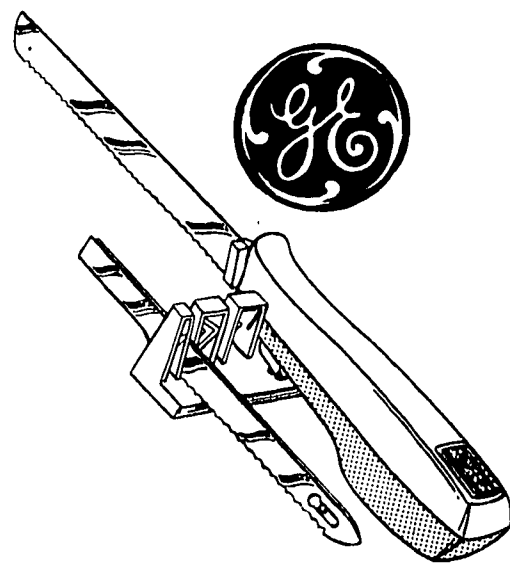

12.67
 Electric Slicing Knife
 Lightweight with 2 sets of stainless steel blades, 9" carving, 6 1/4" paring blades.

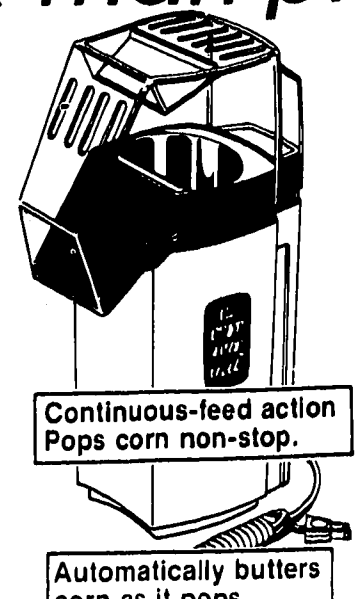

21.97
 Great Hot-Air Popper™
 Popcorn kernels exploded by hot air.

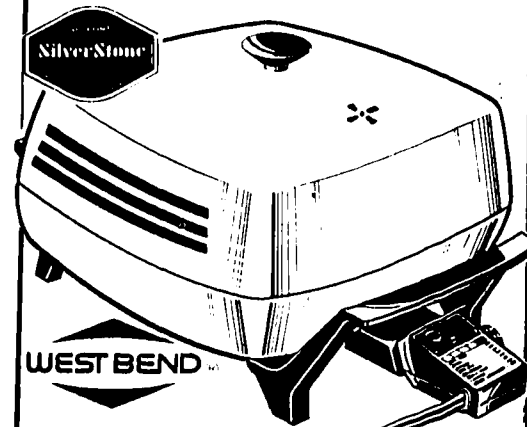

24.87
 12" Electric Frying Pan
 Sensa-Temp control accurately sets temperatures for all types of food. Heavy aluminum with SilverStone™ interior. Save now at K mart.*



13.97
 Electric Heat Wrap™
 Flexible heating pad wraps in heat, straps into place, with sponge for moist heat.

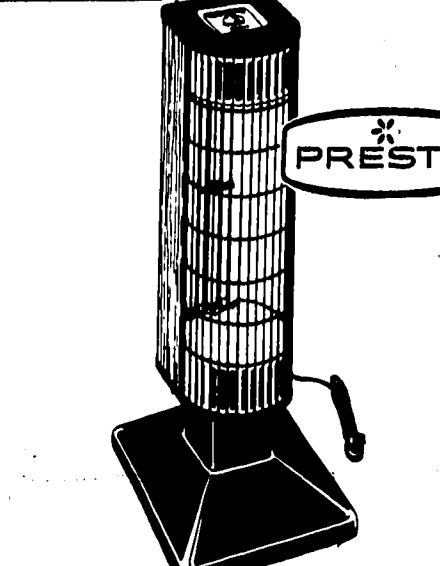

48.87
 1500 Watt Quartz Heater
 Tower of heating power beams heat in wide arc instantly; generates over 5100 BTU heat. Save now.

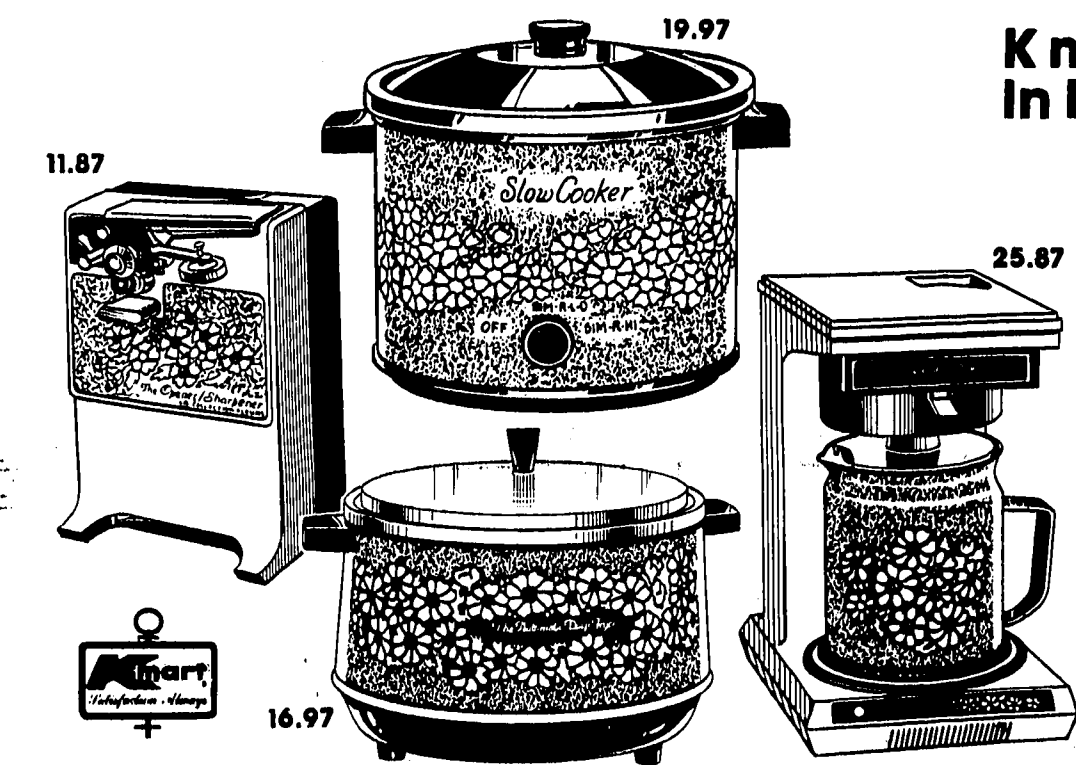

25.87
 10-cup drip coffee maker with steel carafe, saver.
11.87
 Can opener/knife/scissors sharpener with lid magnet.
16.97
 All-purpose 5-qt. family-size fryer; splatter shield.
19.97
 4-qt. slow cooker/server with removable track liner, cover. Save now.

K mart Appliances In Floral Pattern

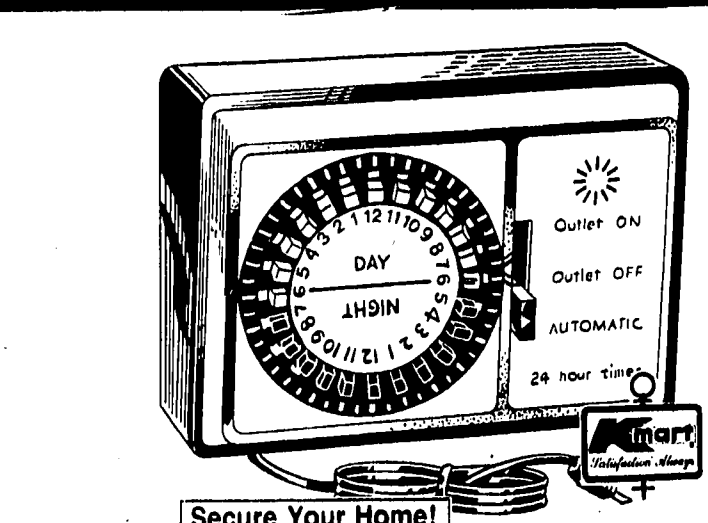

7.88
 Programmable Timer
 24-hr. timer turns lamps, appliances on and off automatically. Save now.

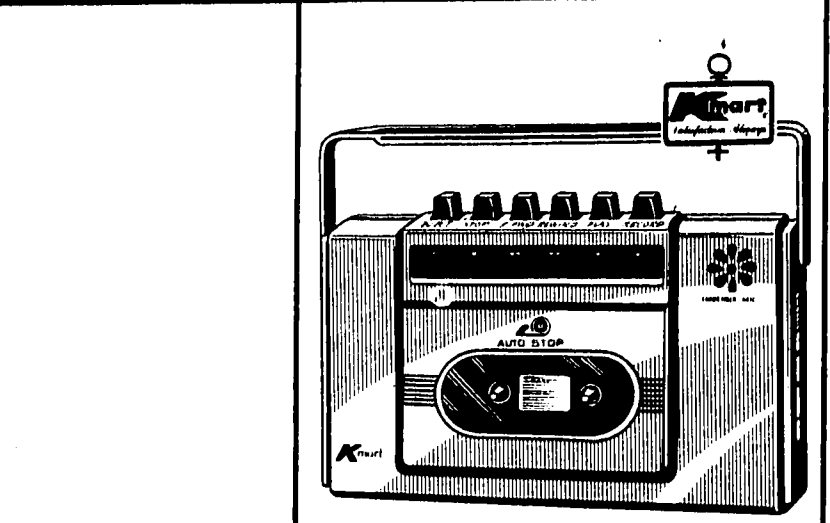

25.97
 Cassette Tape Recorder
 Built-in mike, pushbutton controls. Automatic stop; with jacks for optional AC operation. Save at K mart. Batteries Not included.



23.97
 DC Cassette Recorder
 Built-in condenser mike, easy pushbutton operation. Automatic end-of-tape shut off. Save now. Batteries Not included.



\$88
 Radio/Cassette/8-Track
 AC/DC*-AM/FM radio, cassette recorder, 8-track player, automatic stop. Batteries Not included.

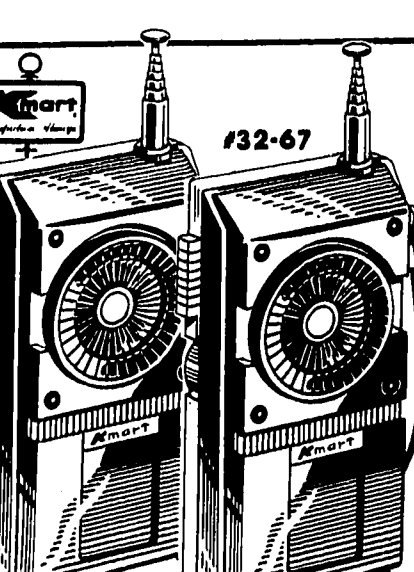

9.97
 4-Trans Walkie Talkie
 Transceiver operates on 9V battery. Adjustable volume. 2" speaker, antenna. Save. Batteries Not included.

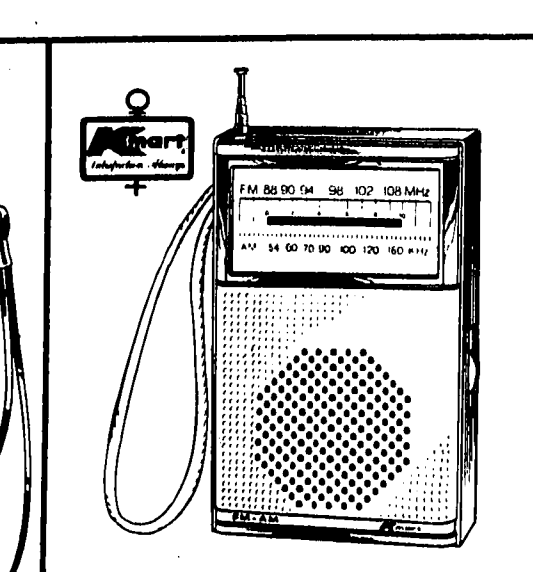

10.47
 AM/FM 9V Pocket Radio
 Direct tuning, telescopic antenna, handle strap, earphone jack. Uses 9V battery. Batteries and Earphone Not included.

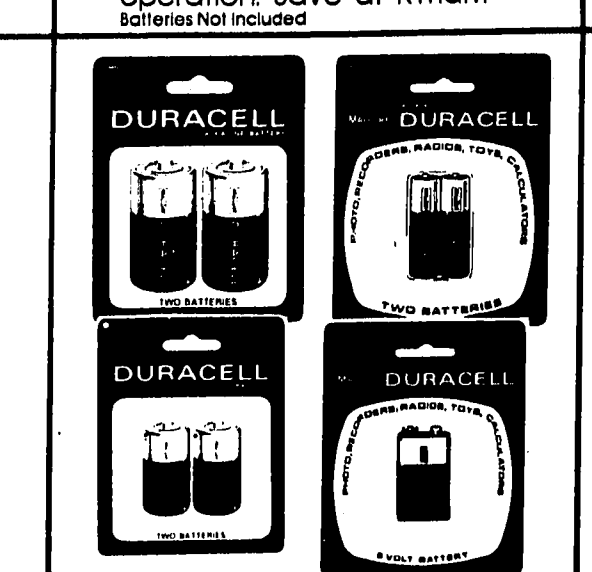

1.17
 Alkaline Batteries
 Card of 2 "AA", "C", or "D" cell alkaline batteries, or one 9-volt alkaline battery. Available in Camera Dept. and Small Appliance Department.



5.44
 Cassette or 8-Track Tape
 Pkg. of 2 blank cassettes or 8-track tape cartridges for 3 hours recording time.

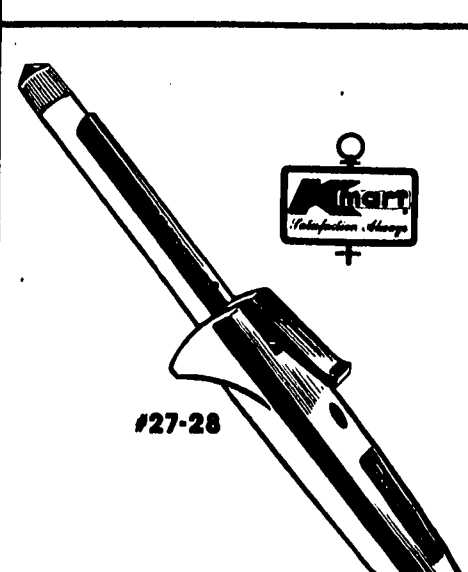

4.77
 Speed-Curl Dry Curler
 Curls without rollers. Has stick-free coating, heat-resistant tip. "On" light.

K mart Reg. Price **\$768**
 Less K mart Discount **\$50**
 Less GE* Rebate **\$50**
Your Net Cost After GE* Rebate \$668

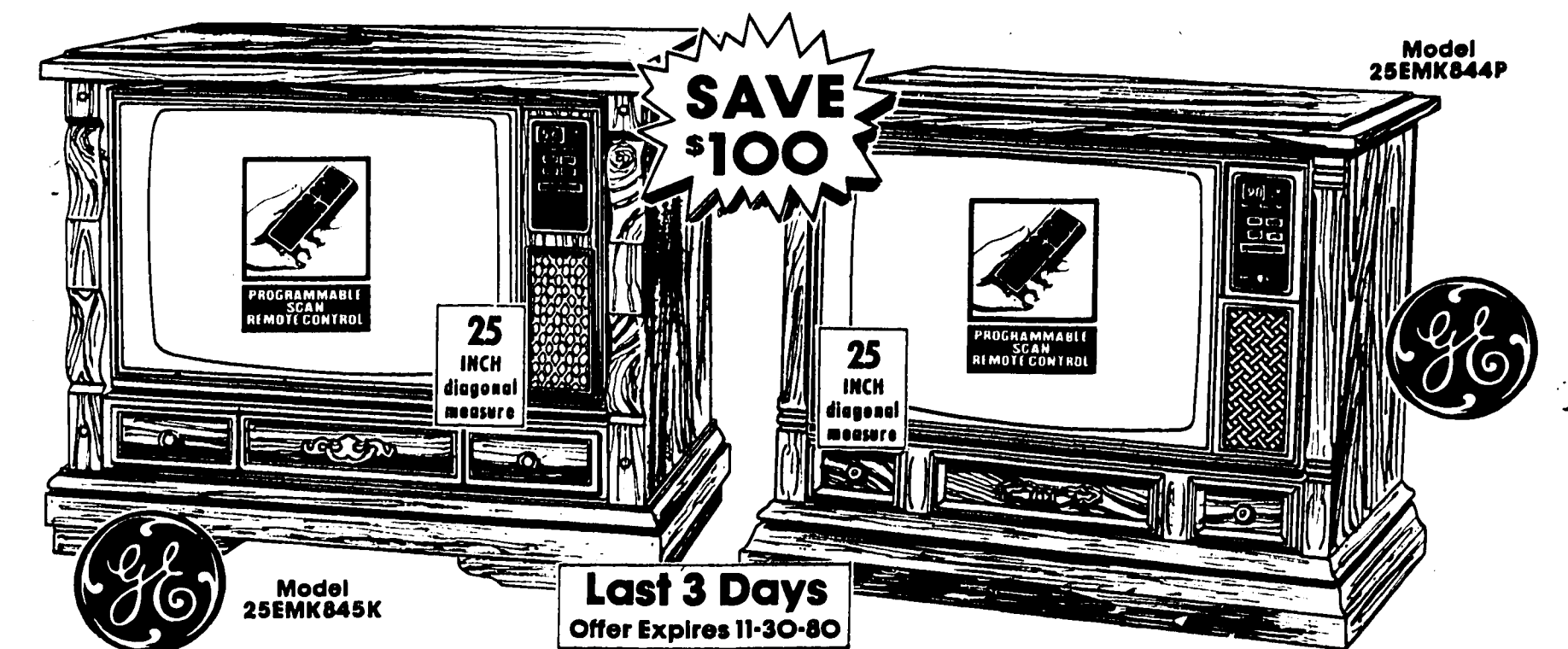

Mediterranean-style Color TV Set
 Our Reg. \$768. Remote control, 91 channels, color control. Rich pecan finish.
Country-style Color TV Console
 Our Reg. \$768. Remote control, distressed oak finish. Many deluxe custom features.

Christmas Savings on Brand Name Gifts

Home Delivery Included on all Color TV Consoles

\$648 Model M4510
 Color TV Console
 Zenith quality with tri-focus, chromatic color control, power sentry. Pecan finish.

\$728 Model SM4515
 Remote-control TV
 Space Command™ remote control, chromatic color control. Antique oak finish.

\$698
 K mart Reg. Price **\$798**
 Less K mart Discount **\$50**
 Less GE* Rebate **\$50**
 Your Net Cost After GE* Rebate **\$698**
 GE* Color TV Console With Remote Control
 VTR broadcast controlled color, 91 channels, quartz electronic tuning. Pecan finish.

\$628 Model GER622
 RCA Color TV With Electronic Tuning
 SignalLock™ tuning, energy-efficient chassis, automatic color control. Pecan finish.
GER623R Color TV with Remote Control \$728

\$668 Model GER637
 Traditional RCA Color TV Console
 SignalLock™ electronic tuning, ExtendedLife™ chassis, color control, AFT. Pecan finish.
GER639R Color TV with Remote Control \$768

\$628 Model GER628
 Pecan-finish RCA Color TV Console
 Excellent color performance with electronic tuning, automatic color control. Energy-efficient chassis. Traditional pecan finish.

\$199 Take With Price Our Reg. \$226
 4-Way Stereo System
 AM/FM stereo receiver, 8-track, cassette recorder/players, record changer.

\$99 Take With Price Our Reg. \$109
 Modular Stereo/8-Track
 AM/FM stereo receiver, 8-track player, automatic recorder changer, twin speakers.

\$128 Take With Price Our Reg. \$148
 Stereo with 8-Track, Phono
 AM/FM/MPX receiver with 8-track player/recorder, record changer, twin speakers.

\$279 Our Reg. \$299 Home Delivery Included
 54" Country French Styled Stereo Console/B-Track
 AM/FM stereo receiver with 8-track recorder/player, 2 mikes; full size BSR record changer with diamond stylus, 2-way speaker system. Rich butter pecan finish.

20% OFF
 Our Regular Price On All Regular In-Stock Speakers

Save \$5 on your holiday purchase! Choose from a variety of sizes and styles. Shop early for the best selection.

17.88
 MacDonald Stereo Headphones
 Ultra-thin, hi-velocity
17.88

9.88
 Fournier Stereo Stand
 Handsome woodgrain finish... **\$55**
9.88

9.88
 Fournier Speaker Stand
 Walnut woodgrain finish... **9.88**

\$199 Our Reg. \$229 Take-With Price
 4-Way Modular Stereo
 AM/FM stereo receiver, 8-track tape, cassette recorder/players, record changer, speakers. Save at K mart.

\$134 Our Reg. \$149 Take-With Price
 22" Music Box Console
 Stereo receiver, BSR record changer, and 5" full-range speakers. Hand-rubbed finish. Save now.

\$367 Delivery Included Our Reg. \$397
 Upright Stereo Console
 Stereo receiver, 8-track tape and cassette players/recorders, record changer. 6 1/2" speakers.

OPEN SUNDAY 10 A.M. TO 8 P.M.

CREDIT TERMS AVAILABLE

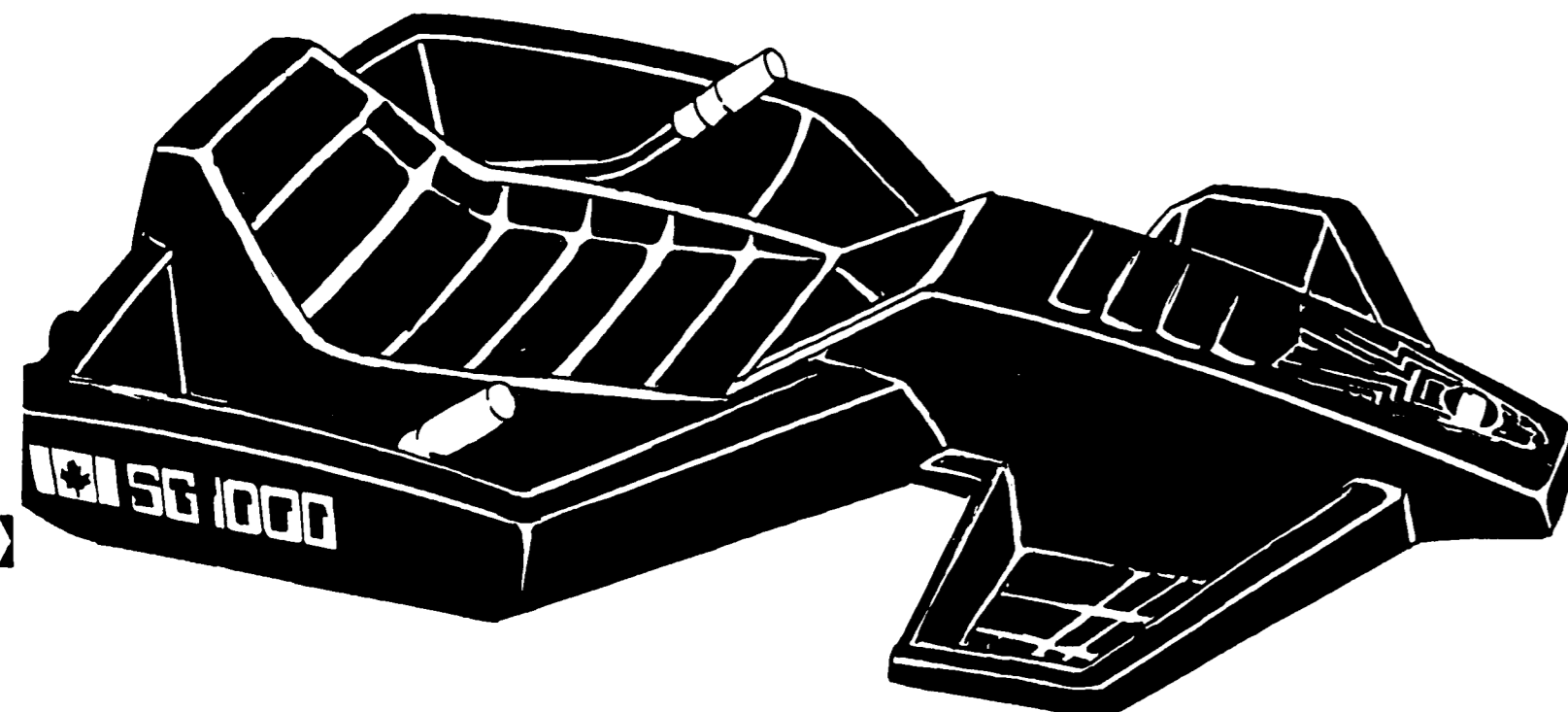

As Seen on T.V.

18.88

Star Gilder SG1000

Large futuristic sled designed. Moulded seat giving good insulation against cold ground. Steel brakes on each side for the dual purpose of steering and braking. Tow rope on front with driving handles.

Big savings on sporting gifts



Save 3.91
12.97 Our Reg. 16.88

Men's Insulated Shirt Jacket
Warm long-sleeved shirt in cotton/polyester flannel with quilted polyester lining. Front pockets. Choice of colorful plaids. Shop K mart's and save.
Men's XXL Size Shirt Jacket 14.97



15.96

Men's or Women's Figure Skates

Low profile styling in white vinyl uppers for women, black vinyl for men. Polyester/fabric lining and perforated, hollow-ground tempered steel blades.
Our Reg. 13.96 Boys' or Girls' Figure Skates 10.88



Not sold where prohibited by law
34.94 22 cal. Our Reg. 42.92
Daisy® Air Rifle
5-shot clip, rifled-barrel rifle.

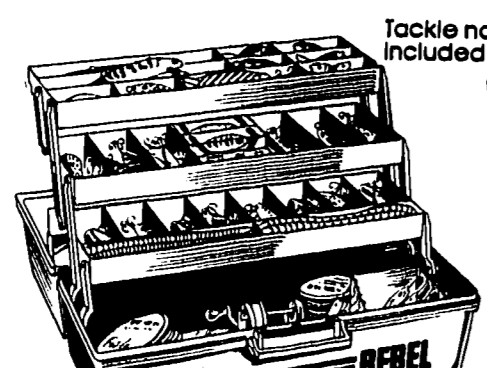

Tackle not included
10.97 Save 2.80 Our Reg. 13.77
Three-Tray Tackle Box
Movable dividers make up to 32 sections. Waterproof, wormproof.



2.88
Marksman® Wrist Sling Shot
Leather launching pouch, 50-lb. pull thrust bands, wrist support.

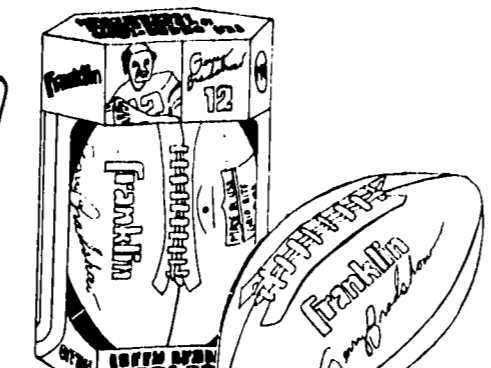

8.66 Save 3.22 Our Reg. 11.88
Terry Bradshaw® Football
Split leather, double lined; official size and weight.

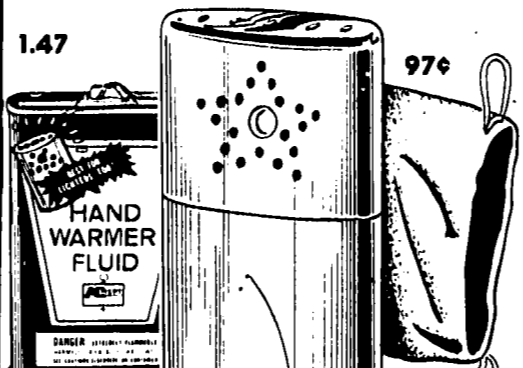

1.47 97¢
Pocket-Size Handwarmer
Runs on lighter fluid; carrying pouch. Our 16-oz. Handwarmer Fluid, 1.47 *9¢ oz.



1.66 Our Reg. 2.19
CO2 Super Powerlets®
High performance, clean piercing, non-leak cap, 12 grams, 5 to box.



10.96 Our Reg. 12.88
Sportsman's Plaid Shirt
Trimly tailored in warm acrylic in a choice of plaids and sizes.

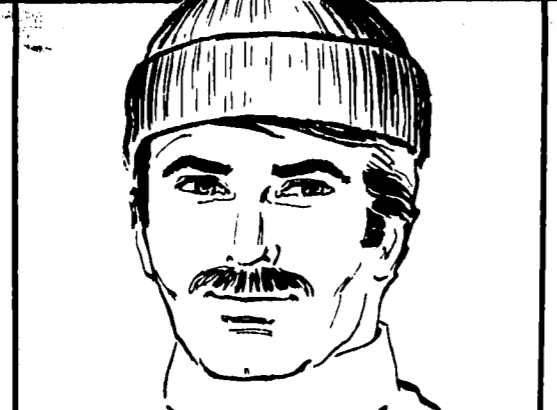

2.97 Our Reg. 3.66
All-Wool Watch Cap
100% heavy-weight wool in a choice of colors. Save now!



4.96 Each Our Reg. 6.88
Tricot Insulated Underwear
Pants or shirt in Dacron® 808 polyester knit, nylon shell, knit lining. Reg. 10.81/9.97. *9.97



Not sold where prohibited by Law
17.88 Save 4.03 Our Reg. 21.91
1600 Powermatic® BB Pistol
Semi-automatic-firing CO2 powered BB repeater. 80 shots, per powerlet. Save.

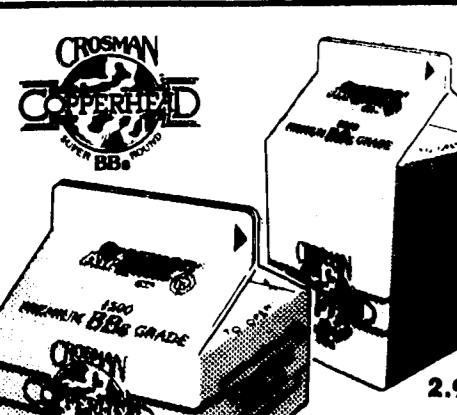

97¢ Our Reg. 1.44
Crosman® Copperhead® BB's
1500 Copperhead® BB's in carton. Our Reg. 3.88 5000 BB's 2.97

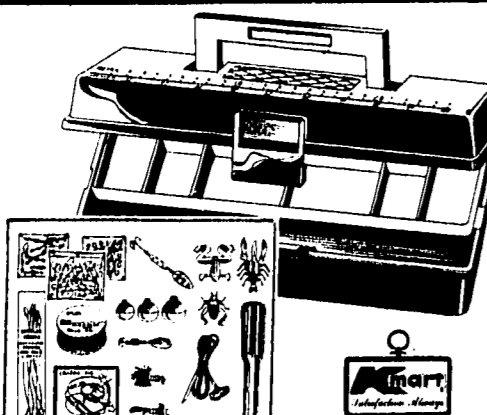

4.47 Our Reg. 5.97
Tackle Box, Accessories
High-impact plastic box with 161 pieces of fishing accessories.

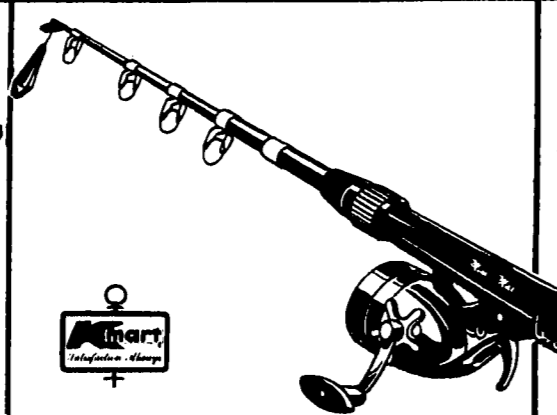

17.88 Save \$6 Our Reg. 23.88
Mini Max® Rod/Reel Combo
6-section telescoping rod; spinning reel, 80-yd. line capacity.



Men's And Boys' Sizes
13.88 Pr.
Converse® All-Star® Oxfords
Canvas oxfords with traction sole, cushion insole, arch support.



66.88
Huffy® Exercise Bike
Tension control, speedometer/odometer. Steel.

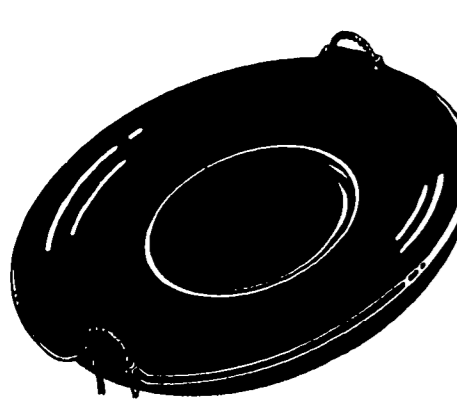

2.97 Our Reg. 4.47
Saucer at Savings!
Winter Fun! 26" dia. molded plastic disc with yellow rope handles.

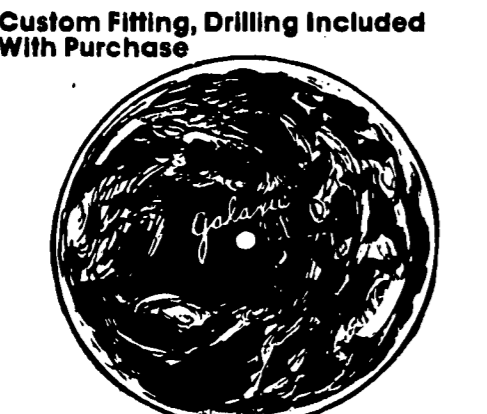

Custom Fitting, Drilling Included With Purchase
19.97 Save 6.91 Our Reg. 26.88
Galaxie® 300 Bowling Ball
ABC approved. Made of hard plastic. Assorted weights and colors.

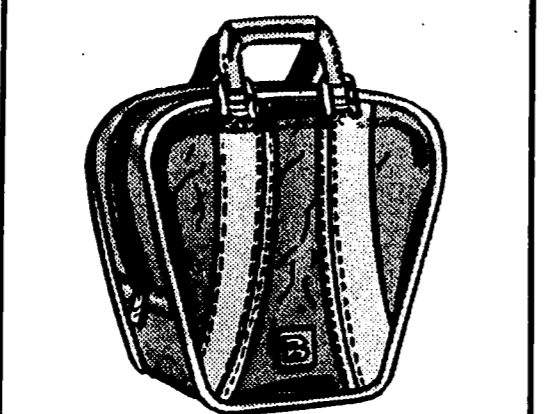

6.88 Our Reg. 7.96
Deluxe Bowling Bag
Expanded vinyl with plastic ball cup; heat-sealed. Color choice.

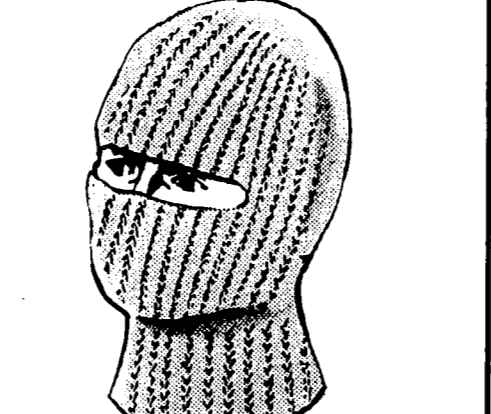

1.97 Our Reg. 2.97
Face-protecting Mask
Protects from cold, wind in warm acrylic. Mask in choice of colors.

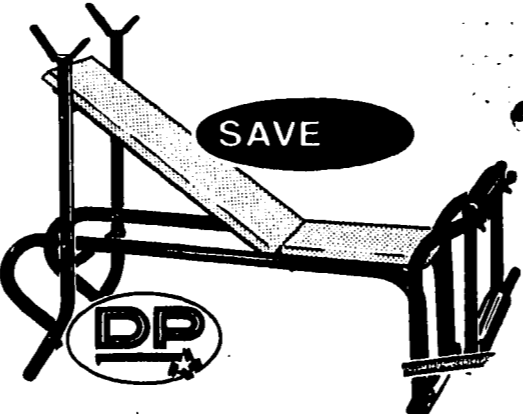

42.88
Exercise Bench
Features leg lift/leg curl apparatus. Adjustable back, padded top.

3.47 Ea. Computer Wheel Balancing			
SIZES	REG.	SALE	F.E.T.
C78x13	31.88	29.88	1.92
B78x13	26.77	22.88	1.77
E78x14	29.77	25.88	1.72
F78x14	31.77	27.88	2.23
G78x14	33.77	29.88	2.38
G78x15	36.77	31.88	2.46

Last 2 Days of Tire Sale

SIZES	REG.	SALE	F.E.T.
P185/75R14	49.88	42.88	2.17
P185/75R13	47.88	40.88	1.93
P225/75R14	57.88	49.88	2.50
P225/75R13	55.88	47.88	2.52
P215/75R14	61.88	52.88	2.65
P215/75R13	59.88	50.88	2.70
P235/75R14	69.88	56.88	1.86
P235/75R13	67.88	54.88	2.90
P235/75R15	69.88	59.88	3.24
P235/75R15	71.88	59.88	2.90

*70° Series Tread Different

MAJOR SERVICE HOURS
8 A.M. TO 9 P.M.
MON. THRU SAT.

18.88 Our Reg. 22.77-778x13 Plus F.E.T. 1.62 Each 'Save On 'KM Economiser' Polyester Cord Tires • Full 78 series tread width	24.88 Our Reg. 26.88-78x13 Plus F.E.T. 1.63 Each 'KMS50' Polyester Cord Mud/Snow Blackwalls • Bias ply construction • Self-cleaning treads	37.88 Our Reg. 44.88-P165/80R13 Plus F.E.T. 1.83 Each 'KM Radial 225' Steel Belted Whitewalls • 5 rib tread design • Radial tire mileage
--	--	--

AUTO CENTER

Shop Our Service Department And SAVE On Low Prices

8.88 Sale Price Front End Car Alignment A "must" adjustment. For many U.S. cars, foreign cars excluded. Additional Parts, or Services are Extra. On Sale Thru Dec. 2	68.88 Many U.S. Cars Disc Drum Brake Special Additional parts, services which may be needed are extra cost. On Sale Thru Dec. 2	42.88 With Exchange Our 56.88 48-month Auto Battery Sealed, never needs water. Many U.S. cars, light trucks. FREE ELECTRICAL SYSTEM CHECK. *Limited 3 Month Free Replacement Limited with 48-Month Pro-rated Adjustment Warranty.	8.88 Ea. Sale Price Deluxe H.D. Shocks Installed 1 1/2" piston, 1/2" shaft. For many U.S. cars. Save at K mart®. Carryout... Ea. 5.88	18.88 Sale Price The Arrestor® Muffler Installed Double wrapped, zinc coated. Many U.S. cars, light trucks. *Additional Parts, Services Extra. Limited (Ownership Duration) Warranty. Warranted as long as you own your car. Details in store. Complete Exhaust System Available. Single Unit (Welded Systems) Excluded.
---	---	--	--	---

1.66 Our Reg. 2.19 CO2 Super Powerlets® High performance, clean piercing, non-leak cap, 12 grams, 5 to box.	10.96 Our Reg. 12.88 Sportsman's Plaid Shirt Trimly tailored in warm acrylic in a choice of plaids and sizes.	2.97 Our Reg. 3.66 All-Wool Watch Cap 100% heavy-weight wool in a choice of colors. Save now!	4.96 Each Our Reg. 6.88 Tricot Insulated Underwear Pants or shirt in Dacron® 808 polyester knit, nylon shell, knit lining. Reg. 10.81/9.97. *9.97	17.88 Save 4.03 Our Reg. 21.91 1600 Powermatic® BB Pistol Semi-automatic-firing CO2 powered BB repeater. 80 shots, per powerlet. Save.	66.88 Huffy® Exercise Bike Tension control, speedometer/odometer. Steel.	1.88 Sale Price Heavy Duty Tune-up Kit Sale Points, rotor, condenser. Save. Our 10.97 Spark Plug Wire Set, 6.88.	1.87 Our Reg. 2.27 Thin Lighted Vanity Mirror Fits all standard auto visors. Uses AA batteries*. Save now.	8.96 'Big Book' of Auto Repair Easy step-by-step instructions, diagrams for American cars.	64.44 Our Reg. 84.88 Dual Mount Cruise Control Mounts on blinker arm or under dash. For cars, trucks or R.V.'s. Save.	7.97 Sale Price Save on Versatile Foot Pump Well-built pump comes with pressure gauge. For tires, toys, and more.
2.97 Our Reg. 4.47 Saucer at Savings! Winter Fun! 26" dia. molded plastic disc with yellow rope handles.	19.97 Save 6.91 Our Reg. 26.88 Galaxie® 300 Bowling Ball ABC approved. Made of hard plastic. Assorted weights and colors.	6.88 Our Reg. 7.96 Deluxe Bowling Bag Expanded vinyl with plastic ball cup; heat-sealed. Color choice.	1.97 Our Reg. 2.97 Face-protecting Mask Protects from cold, wind in warm acrylic. Mask in choice of colors.	42.88 Exercise Bench Features leg lift/leg curl apparatus. Adjustable back, padded top.	3.27 Our Reg. 4.17 Super Snack Car Console Snack tray, hinged lid litter basket, tissue dispenser with tissue.	8.96 Our Reg. 11.88 Foam-backed Seat Cover Sale 2-tone, foam-backed polyester covers for 2- or 4-door styles.	36¢ Sale Price K mart® Gas Line Anti-freeze New plastic pour spout. Helps prevent freezing, clogging. 12-ozs.	49.88 Diagnostic Engine Analyzer With inductive pick-up. 4-6-8-cyl. cars. Our 38.88, timing light 28.96.	1.47 Sale Price Equals or exceeds auto manufacturers' specifications. For most cars. Save.	

OPEN SUNDAY 10 A.M. TO 8 P.M.

CLOSED THANKSGIVING

Open Daily 9-10; Sunday 10-8

Kmart
The Saving PlaceSM

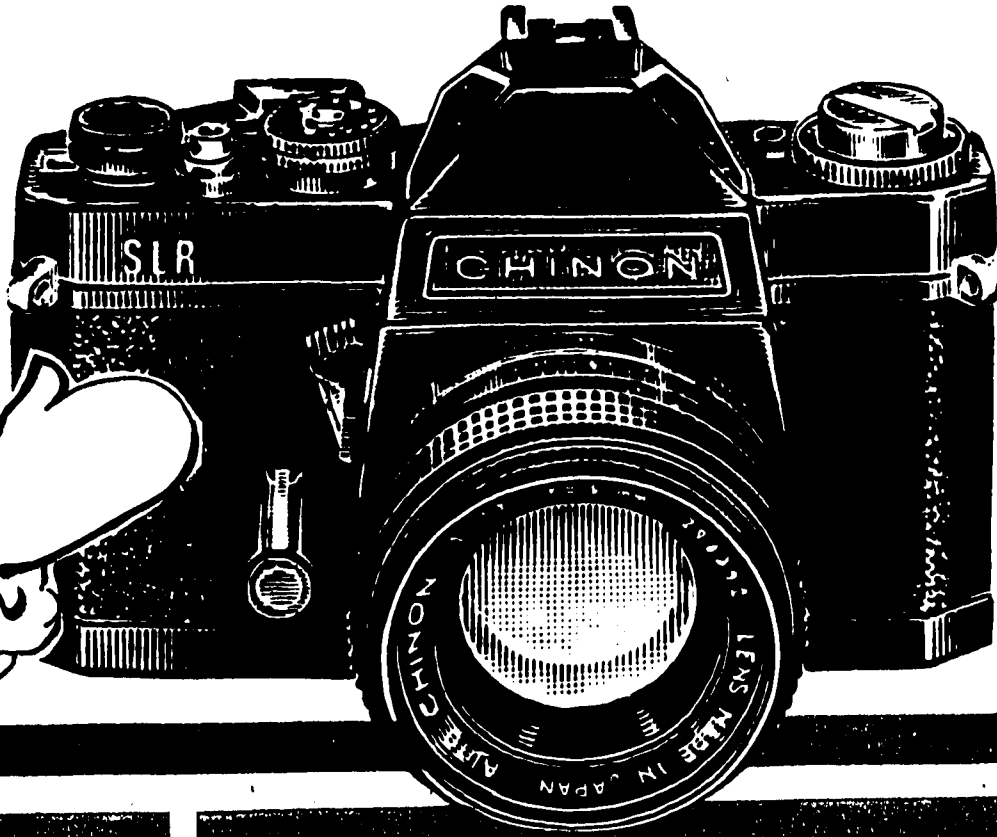

CHINON

139.88

• Chinon® 35mm SLR Camera with Case

Versatile, easy-to-use 35mm camera with a f1.7 screw-mount lens, shutter speeds from 1 to 1/1000 sec., TTL meter system, built-in hot shoe, and self-timer. ASA range 10-1600.



YASHICA

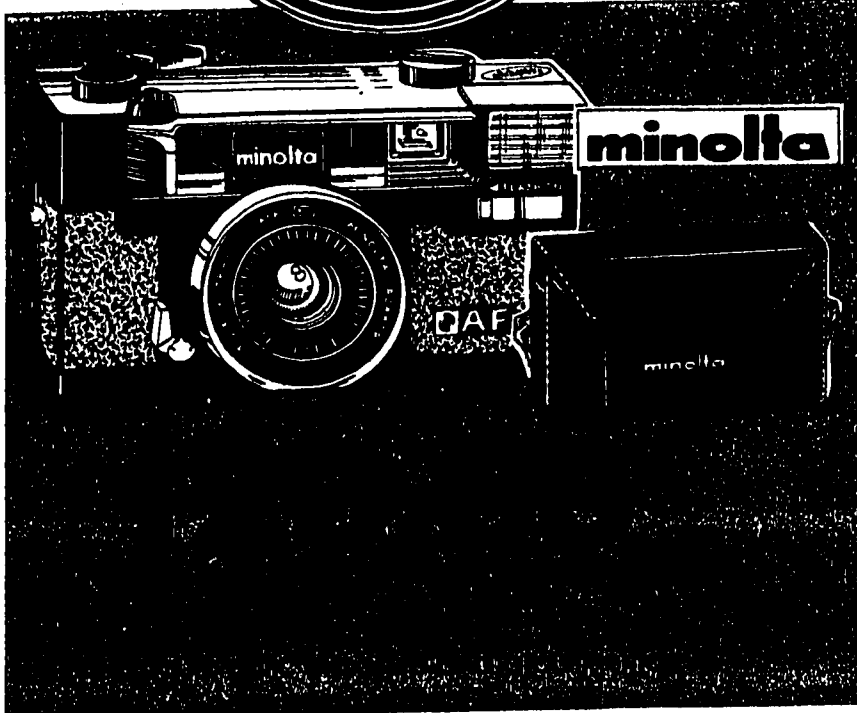

minolta

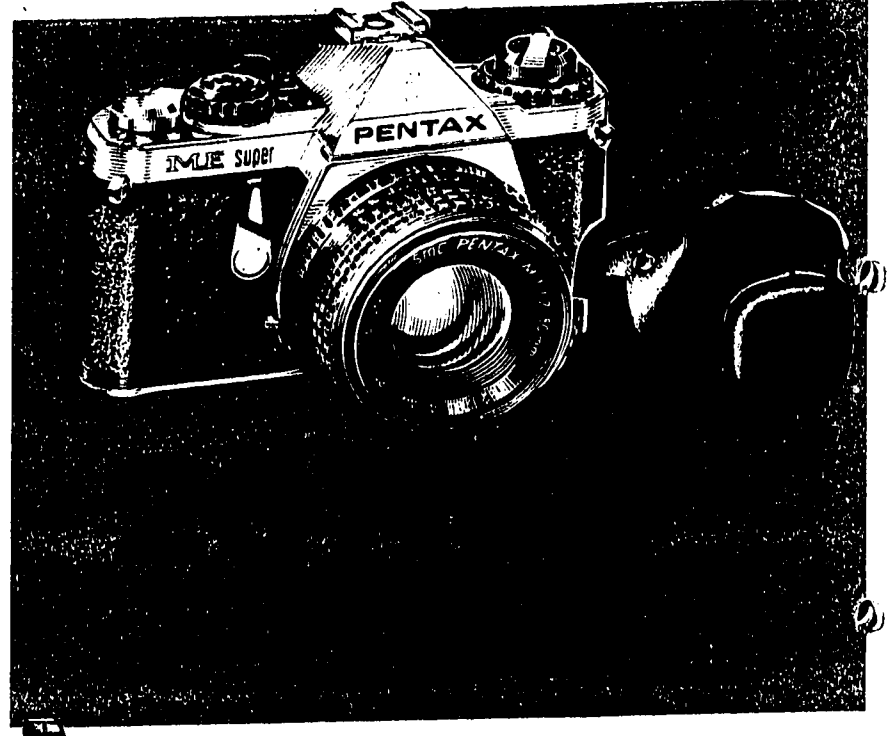

PENTAX



2.97
ASA 400

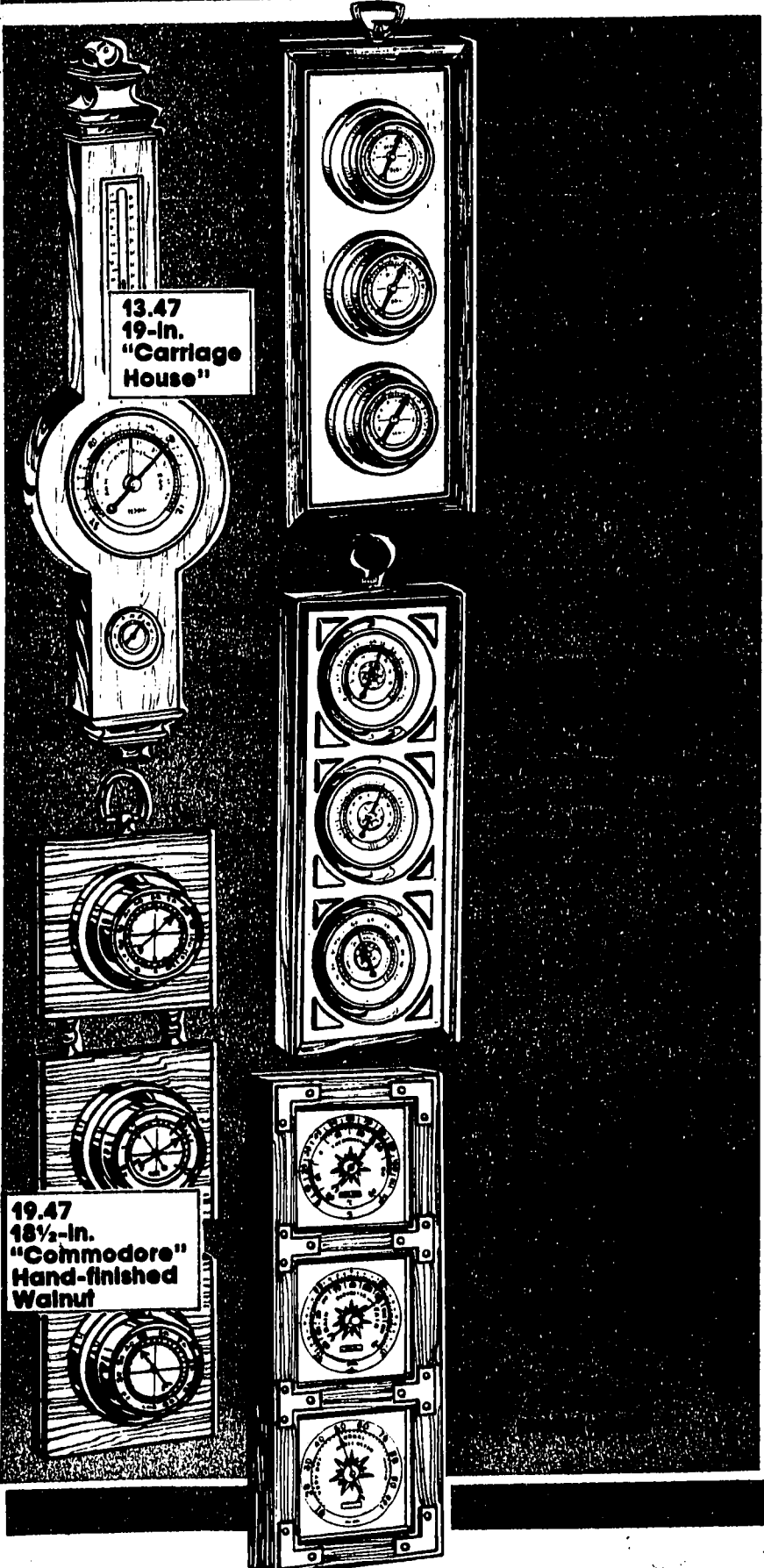
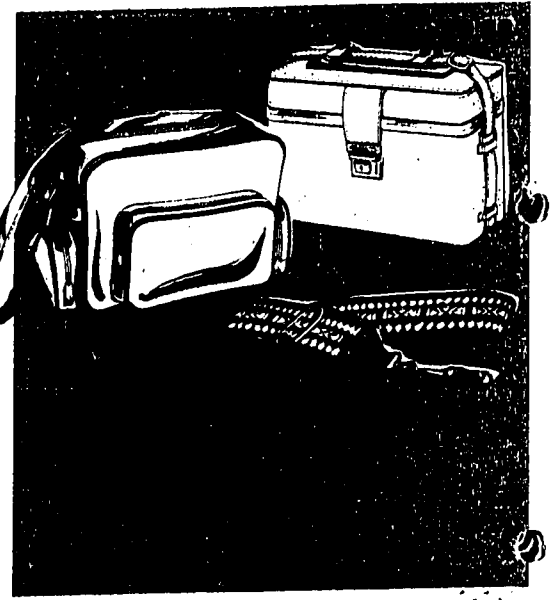
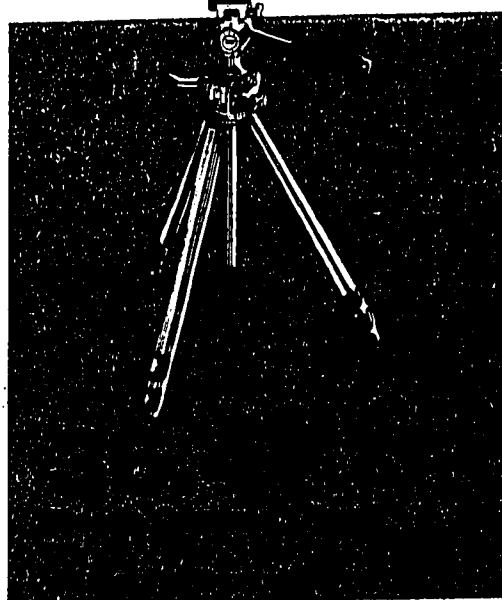
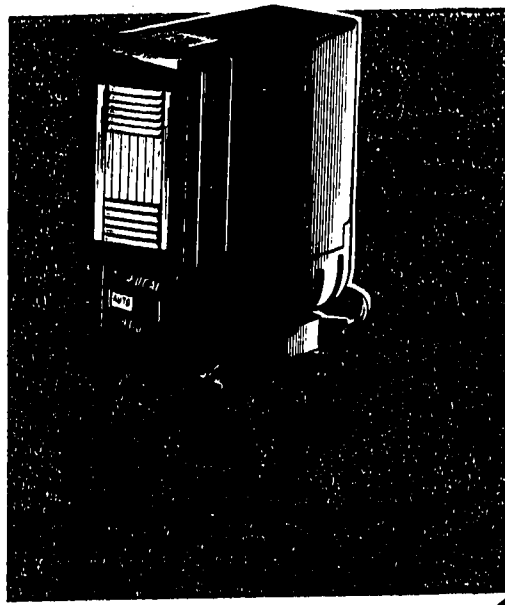
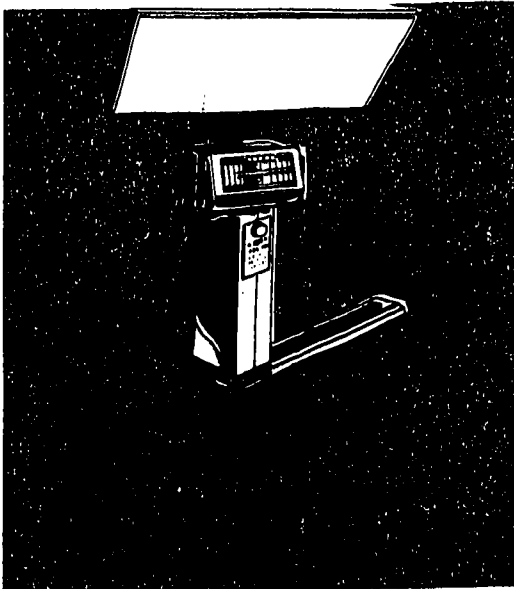

13.47
19-in.
"Carriage
House"

19.47
18 1/2-in.
"Commodore"
Hand-finished
Walnut

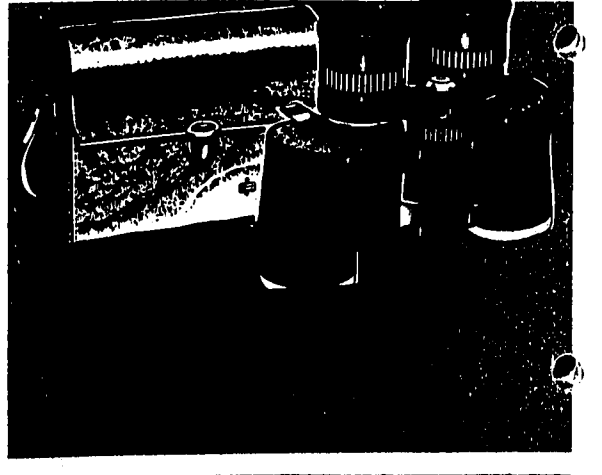
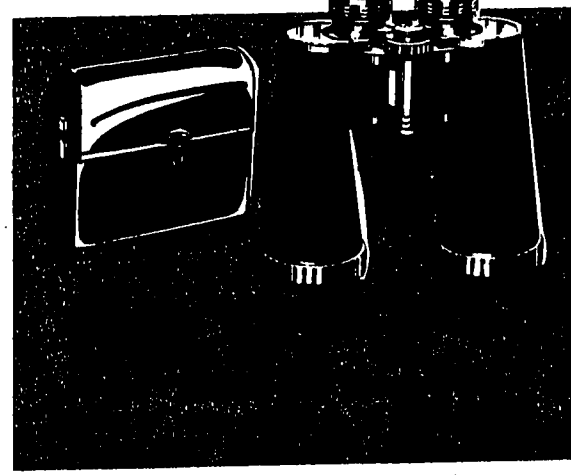
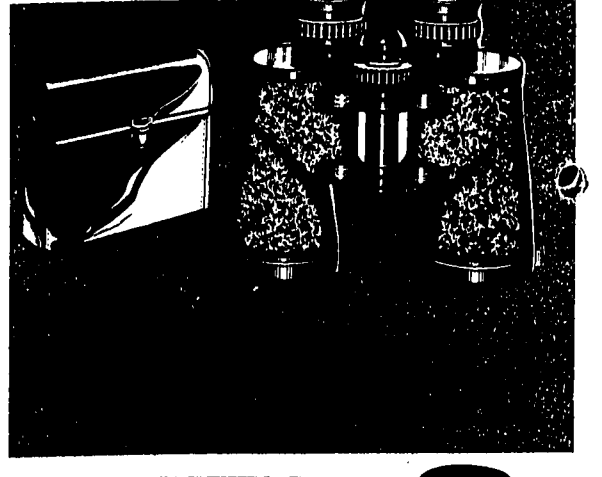
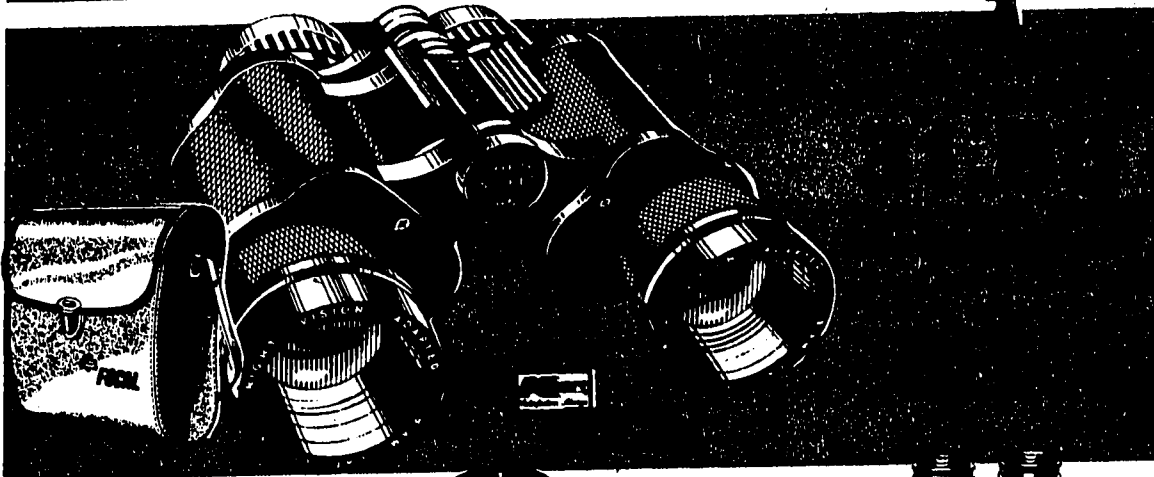
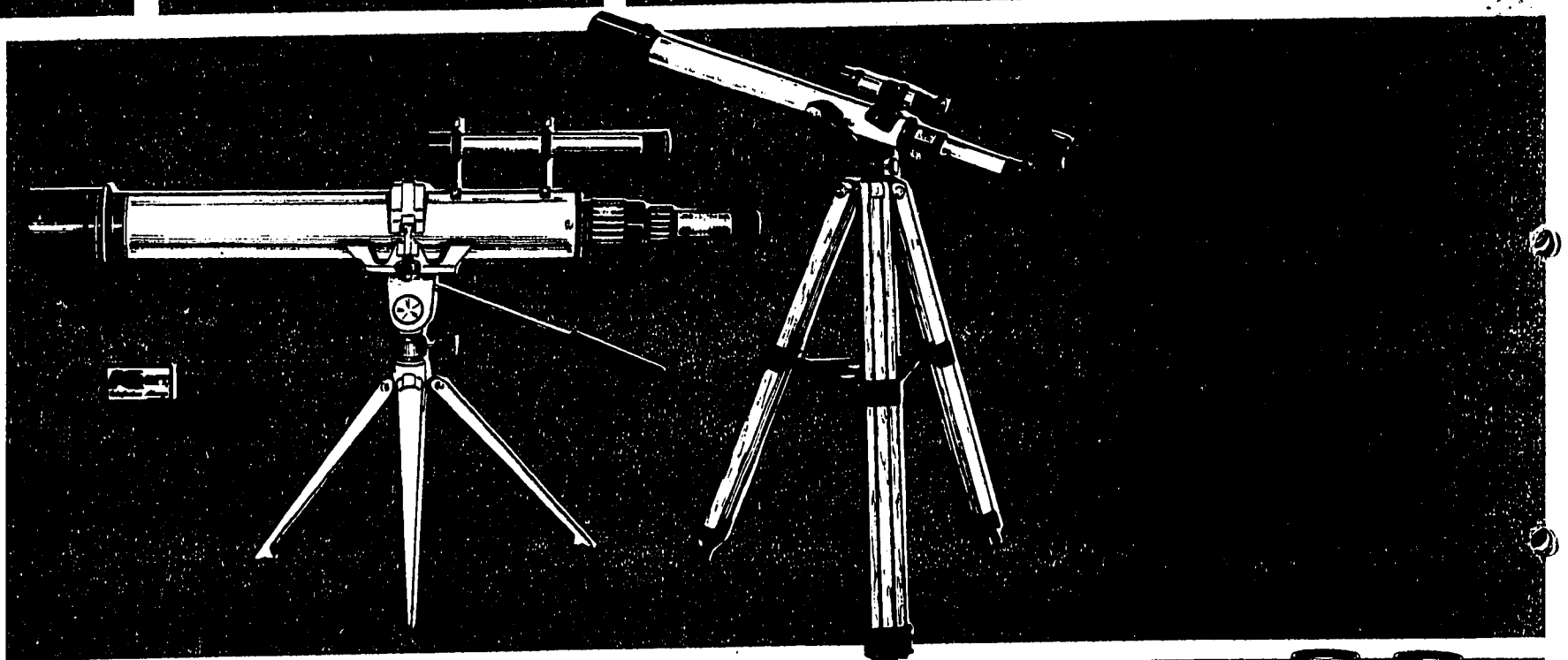

Kmart

48 Stores In The Greater Detroit Area To Serve You!

DAILY 9-10
SUNDAY 10-8

TG&Y Items On This Page Available In Family Centers Only

ONE STORE ONE STOP... for CHRISTMAS

TG&Y knows that you're trying to save money...but why should this Christmas be any different than past years? Save gas and money by shopping for all your family and friends at TG&Y...for the gifts they want at prices you want!

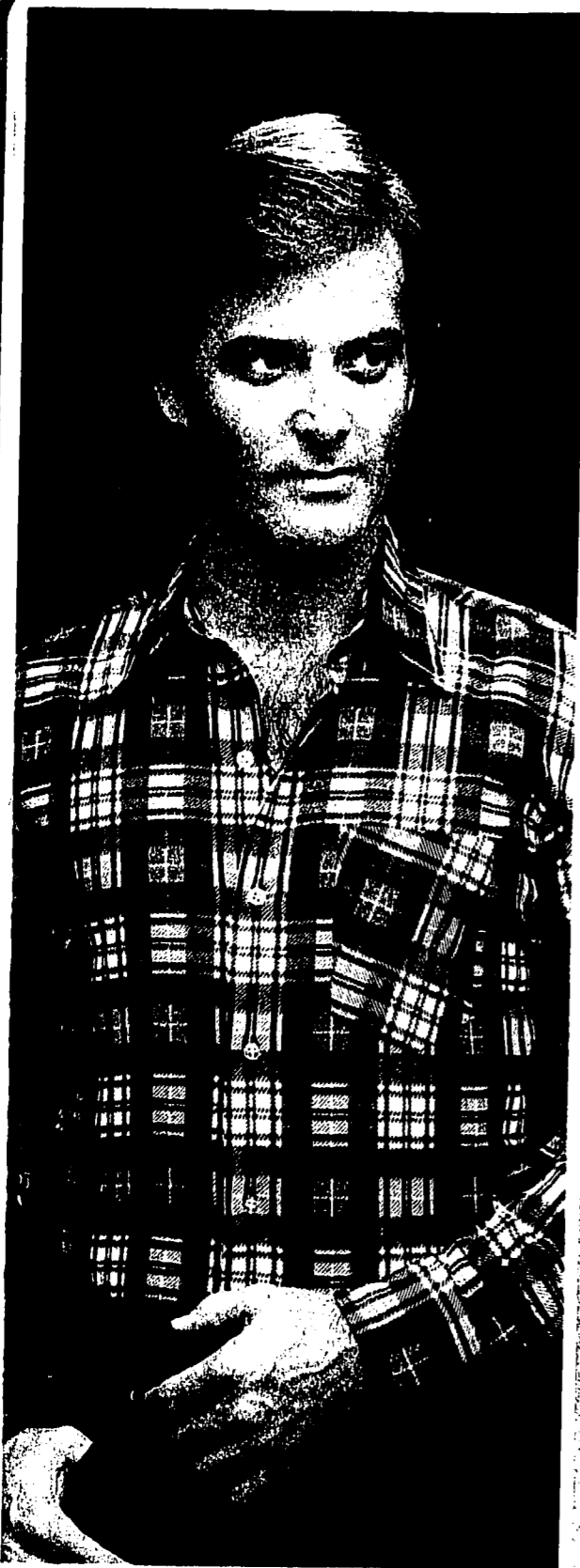

3.99 save 1.98
Men's Flannel Shirt Long tail... long sleeves, just right for wintertime wearing! Made from 100% pre-shrunk cotton in various plaids. Convenient chest pocket. Sizes S-XL. Reg. 5.97

Norelco®
Rechargeable... NEW
"face grooming" kit...

49.88 save 10.11
Norelco® Rotatract™ Cord or cordless shaving... world wide! One charge lasts up to 3 weeks! The original triple-head razor with Microgroove™ heads and 45 twin-action retractable blades that follow the contour of the face. All-new shave counter, pop-out sideburn and mustache trimmer. #1318. Reg. 59.99. Limit 1



9.97
Tonka® "Mighty" Dump Truck A most popular Tonka® toy! Realistically-styled cab with tilt-back dump bed. 18 1/2" overall length. Limit 1



33.96
LJN® 255 Computer Command™ Car Command panel offers a selection of up to 255 programs. Even to lights, horn and siren!



7.99 save 5.24
Fisher Price® Play Desk Steel magnetic chalkboard with magnetic letters, activity cards and more. Ages 3 to 8. Reg. 13.23. Limit 1



7.99 save 3.89
Hasbro® Hungry Hungry Hippos™ Manipulate the levers so your hippo can snatch the most marbles! Ages 4 to adult. Reg. 11.88. Limit 1



8.96 save 2.03
Eugene® Baby 'n Carry Seat. 18" drink and wet doll in sturdy plastic seat. With accessories. Reg. 10.99

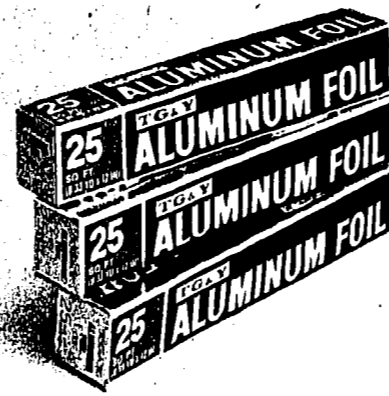

3 FOR 1.00
TG&Y® Aluminum Foil 12" wide, 25 sq. ft. per roll. Limit 3 rolls



.99
Cepacol® Mouthwash Price reflects 30% off label. 18 oz.



1.99
L'Oréal® Excellence® Hair Color Contains one application.

Your best Christmas buys are at

TG&Y
family centers

November Circular #48, 1980

CHARLOTTE
• 515 Lansing Street
MASON
• MASON PLAZA
540 North Cedar
CENTERLINE
• 7407 E. Ten Mile Rd.

NOVI
• 41800 Ten Mile Rd.
NORTHVILLE
• 42435 W. Seven Mile Rd.
ALMA
• 1720 Wright Ave.

Advertising Supplement:
Charlotte Shopping Guide
Eaton Rapids Flashers
Ledges Shopping Guide
Hastings Reminder
Marshall Advisor
Mason Shopping Guide
Northville Record
Novi/Walled Lake News
South Lyon Herald
Plymouth Observer
Macomb Daily/Community News
Alma Reminder

SALE ENDS. DEC. 2

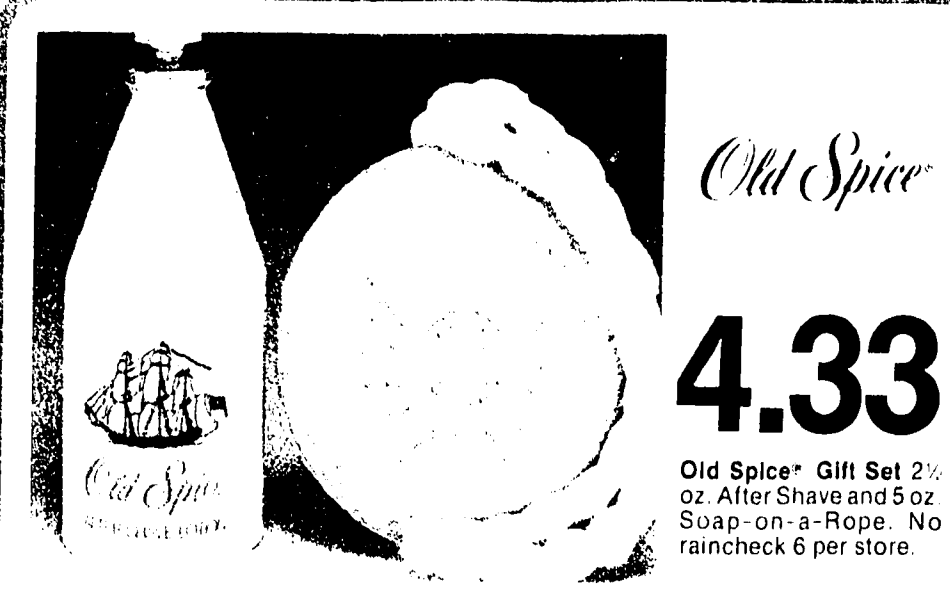

Old Spice

4.33

Old Spice® Gift Set 2 1/2 oz. After Shave and 5 oz. Soap-on-a-Rope. No raincheck 6 per store.



English Leather

4.17

English Leather® Gift Set 2 oz. After Shave and 2 oz. Cologne. A set for the man! No raincheck 6 per store.



Love's Baby Soft

4.57

Love's Baby Soft® Gift Set 1 oz. Body Mist and 1.5 oz. Powder. No raincheck 6 per store.

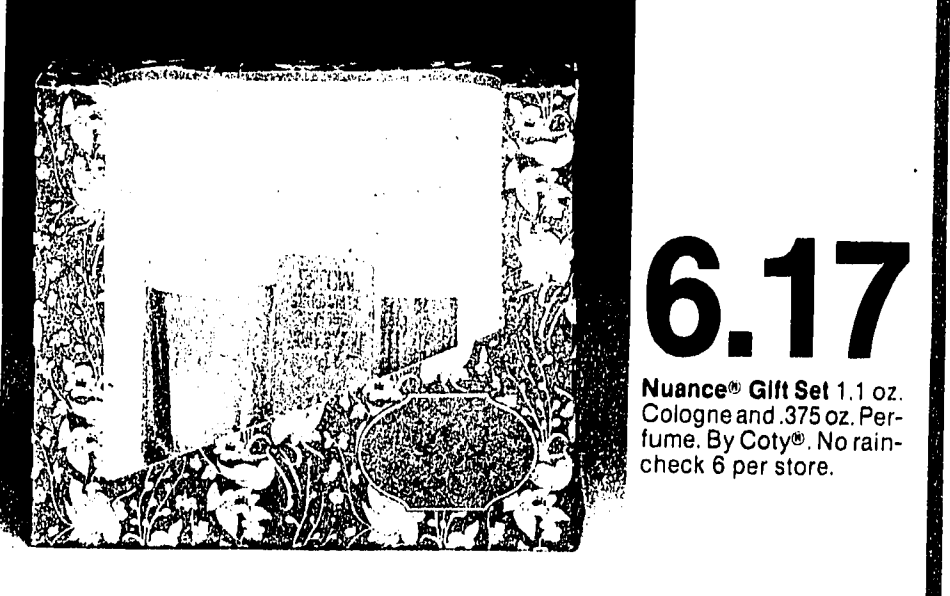

Nuance

6.17

Nuance® Gift Set 1.1 oz. Cologne and .375 oz. Perfume. By Coty®. No raincheck 6 per store.

Richly-designed ladies' lingerie . . . silkiness and savings for you at TG&Y!



DUPONT Antron III

6.50
A. Ladies' Lace Full Slip 100% Antron® III* nylon comfortably helps smooth out undergarment lines. Navy, burgundy or nude shades with lace trim. 32-40. Reg. 6.97

4.50
B. Ladies' Lace Camisole Beautifully feminine undergarment for sheer blouses! 100% nylon with smooth lace trim. Navy, burgundy or nude. S-M-L. Reg. 4.97

3.97 save 1.00
C. Ladies' Lace Half Slip For those who prefer the comfort of a half slip! Sleek, 100% Antron® III* nylon with lace trim. Navy, burgundy or nude shades. S-M-L. Reg. 4.97

1.47
Ladies' Lace Bikini 100% nylon in navy, burgundy or nude shades. Sizes 5-7. Reg. 1.79

1.67
Ladies' Lace Brief 100% nylon, smooth lace trim. Navy, burgundy or nude. 5-6. Reg. 1.99

When it comes to fashion TG&Y knows what's "in", now . . . and has it for you at a savings!

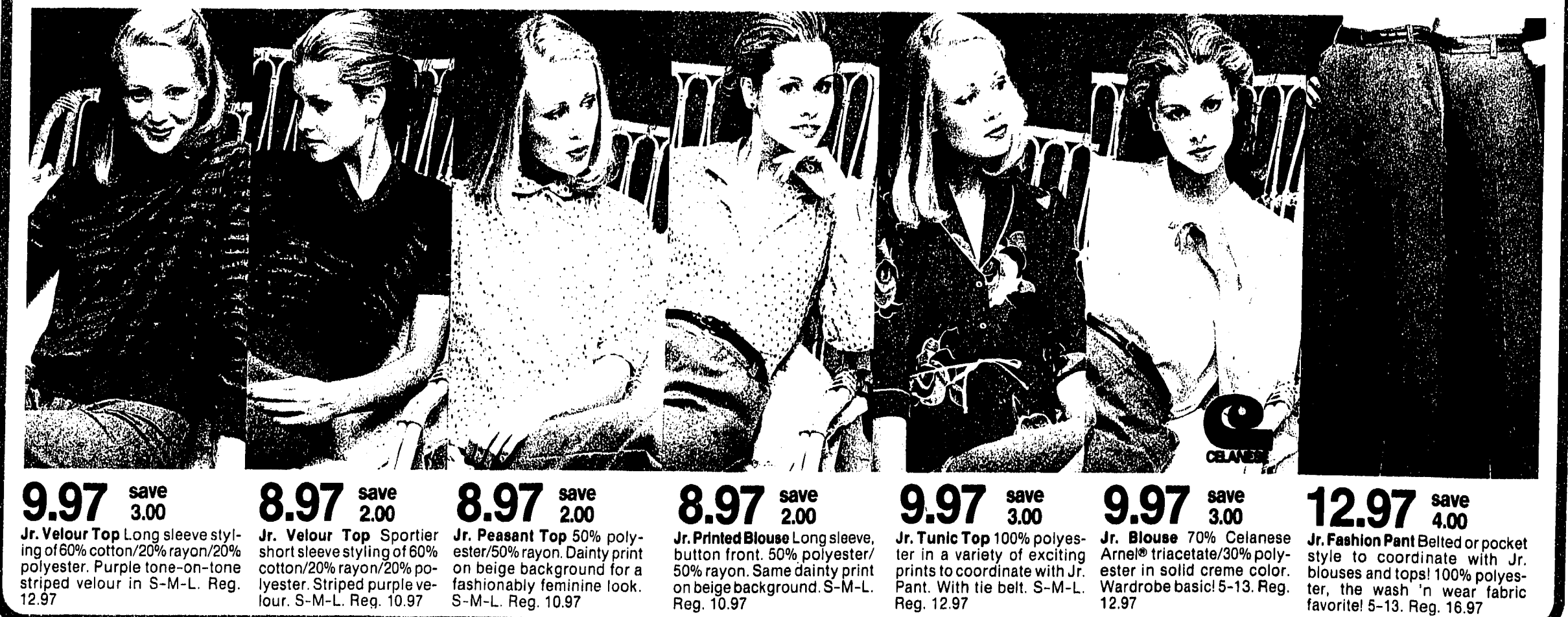

9.97 save 3.00 Jr. Velour Top Long sleeve styling of 60% cotton/20% rayon/20% polyester. Purple tone-on-tone striped velour in S-M-L. Reg. 12.97

8.97 save 2.00 Jr. Velour Top Sportier short sleeve styling of 60% cotton/20% rayon/20% polyester. Purple tone-on-tone striped velour in S-M-L. Reg. 10.97

8.97 save 2.00 Jr. Peasant Top 50% polyester/50% rayon. Dainty print on beige background for a fashionably feminine look. S-M-L. Reg. 10.97

8.97 save 2.00 Jr. Printed Blouse Long sleeve, button front. 50% polyester/50% rayon. Same dainty print on beige background. S-M-L. Reg. 10.97

9.97 save 3.00 Jr. Tunic Top 100% polyester in a variety of exciting prints to coordinate with Jr. Pant. With tie belt. S-M-L. Reg. 12.97

9.97 save 3.00 Jr. Blouse 70% Celanese Arnel® triacetate/30% polyester in solid creme color. Wardrobe basic! 5-13. Reg. 12.97

12.97 save 4.00 Jr. Fashion Pant Belted or pocket style to coordinate with Jr. blouses and tops! 100% polyester, the wash "n wear fabric favorite! 5-13. Reg. 16.97

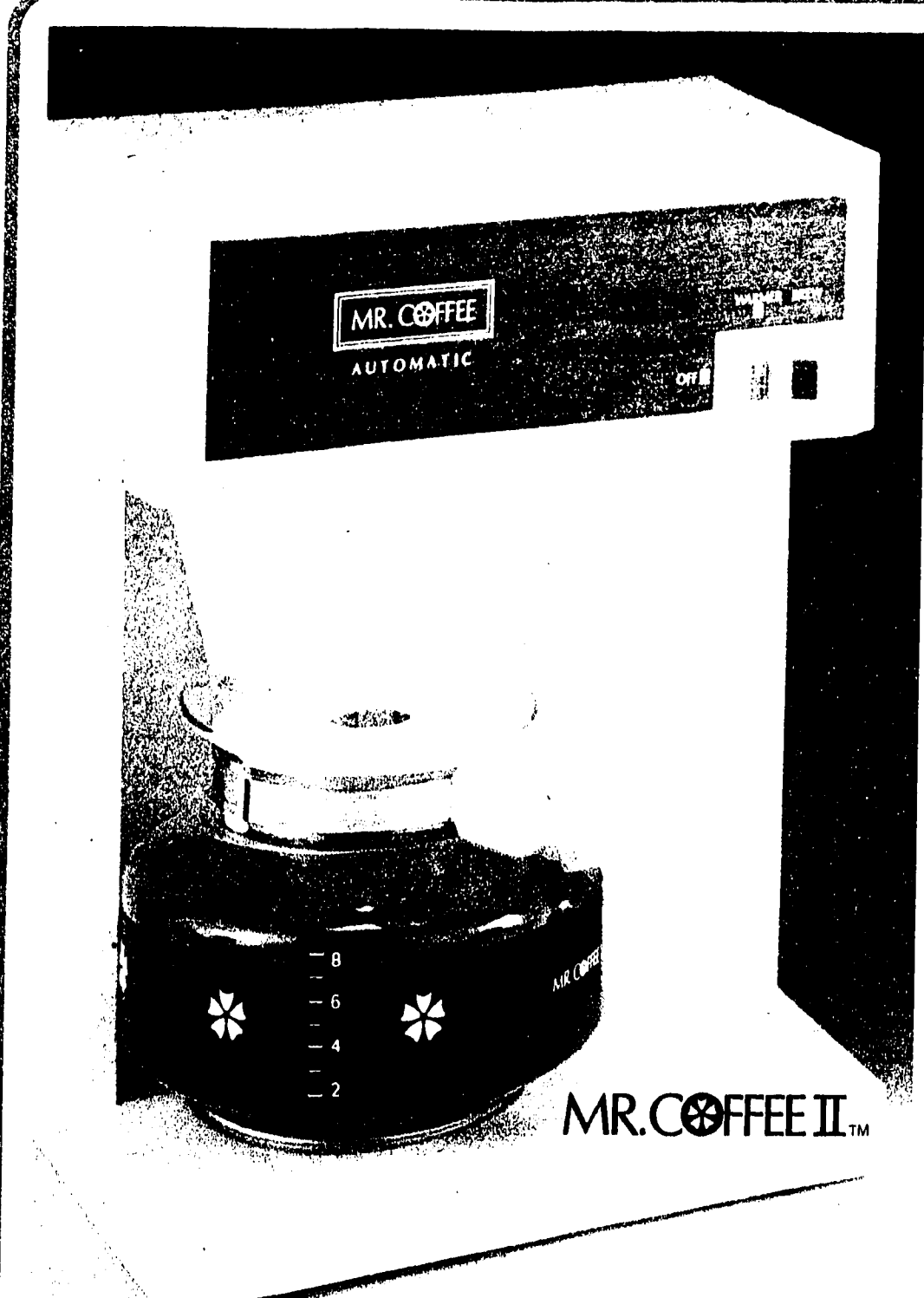

MR. COFFEE II AUTOMATIC

19.99 save 3.00

Mr. Coffee II® Automatic Coffeemaker Want a good cup of coffee fast? Well, Mr. Coffee II® delivers in just 3 minutes! Makes 2 to 10 cups. Holds at serving temperature. #CB600. Reg. 22.99. Limit 1

34% off popular Star Wars™ figures!

Kenner

96

Kenner® Star Wars™ Figures Exciting action figures. 2 1/2 to 4 1/2" high, with movable arms and legs. Reg. 2.49 ea.



CONAIR PRO 1200

Low Price . . . **10.88**
Mail-in Rebate* . . . **- 2.00**
Your Final Cost . . . **8.88**

Conair® Pro 1200 Hair Dryer Dries hair quickly. 1200 watts with 2 speeds and 2 heat settings. #053. Reg. 14.99. Limit 1

4.96 Mattel® Hot Wheels™ Machines Choice of 4 mini collections. 6 die-cast metal cars per set. Each machine pack sold separately.

5.99 save 2.00 Northern® Hot Pro Styling Wand Hot brush, hot wand or hot comb! #2337. Reg. 7.99

Crest TOOTH PASTE REGULAR FLAVOR **15% OFF**

6.97 Crest® Toothpaste 5 oz. Price reflects 15% off label. Limit 2. No raincheck 48 per store.

The Christmas tree that saves you year after year!

11.87

Artificial Scotch Pine Tree This big, bold 6' artificial pine tree will brighten your home with holiday cheer for years to come! 31" diameter, with 43 full, flame-proof branches and 71 tips. Includes sturdy, hi-impact plastic stand. Easy assembly.



Decorations not included

.76 Jumbo Roll Gift Wrap 26" wide. Assorted design. Paper, 35 sq. ft. total; or Foil in prints or solids, 15 sq. ft. total.

.47 Christmas Bows The finishing touch! 25 self-adhesive bows in bright colors.

.97 ea. Scented Pillar Candles Red or green. No raincheck 3x3", 96 per store; 3x6", 132 per store.

1.87 ea. Outdoor Light set 25 size C9 1/4 bulbs. If one goes out, the rest stay on. Multiple colors.

6.97

ONE STORE ONE STOP... for

TG&Y family centers

CHRISTMAS

TOYS...

Games & Yoyos! All for Christmas at TG&Y ...

ADVERTISED MERCHANDISE POLICY
Our company's policy is to always share it in TG&Y's policy to be priced competitively in the market. Regular supply in our stores. In the event the advertised merchandise is not available, we will substitute a similar quality merchandise at a similar price reduction. It is the policy of TG&Y to see that you are happy with your purchases.

7.96 save **2.03**



Animals Cuddly and cuddly, 17" tall. These plush little friends are ready for Christmas! Select from elephant, pup, mouse or bear. A little one's dependable pal! Reg. 9.99

8.88



Fisher-Price® Rodeo Rig Your little "partner" can "saddle-up" for hours of fun! Colorful plastic truck has drop-down tailgate. Rider has moveable arms and legs, horse comes with saddle.

6.94



CHIPS® Motorcycle Helmet Set Just like on TV! The adventure-packed fun of "Ponch and Jon" for Christmas! Includes helmet with visor, gun and holster, handcuffs, badge and more.

3.27 save **27%**



Play Farm or Circus Puzzle Bright red barn with 6 farm animals or a big green circus truck with 5 circus animals. Each animal is a free-formed play block. Reg. 4.48

3.97



Zap • Pow • Zing Game Target shoot game with pistol, six safety darts, target stand and score counter.

3.96



Strollin' Bowling® Compact bowling game. Open the case... it's a mini bowling alley! Wind-up the crazy ball and watch it knock over pins!

7.97 save **1.91**



Jogger Shoe Skate Rider® Big red molded plastic shoe, with white rippled "sneaker" sole, handle, seat and skate-type wheels. Toddler fun! Reg. 9.88

11.88



Race Car Hauler Set A Christmas winner! Tough "Louisville" type hauler, with Z-28 Camaro® replica racer. Two moveable figures, jack, tool box, ramps and more.

2.96 each set save **22%**



Tootletoy® Metal Car Sets Select from Open Road, California Fun, Jet Flight Line or Fire Fighter play sets. A Christmas best buy from TG&Y and Strombecker®! Reg. 3.79 set

GiFTS... every homemaker could use at special TG&Y savings!



save 1.00
11.96

G. E.® Hand Mixer Convenient, lightweight, 3-speed portable. In decorator white or gold. #M24. Reg. 12.96

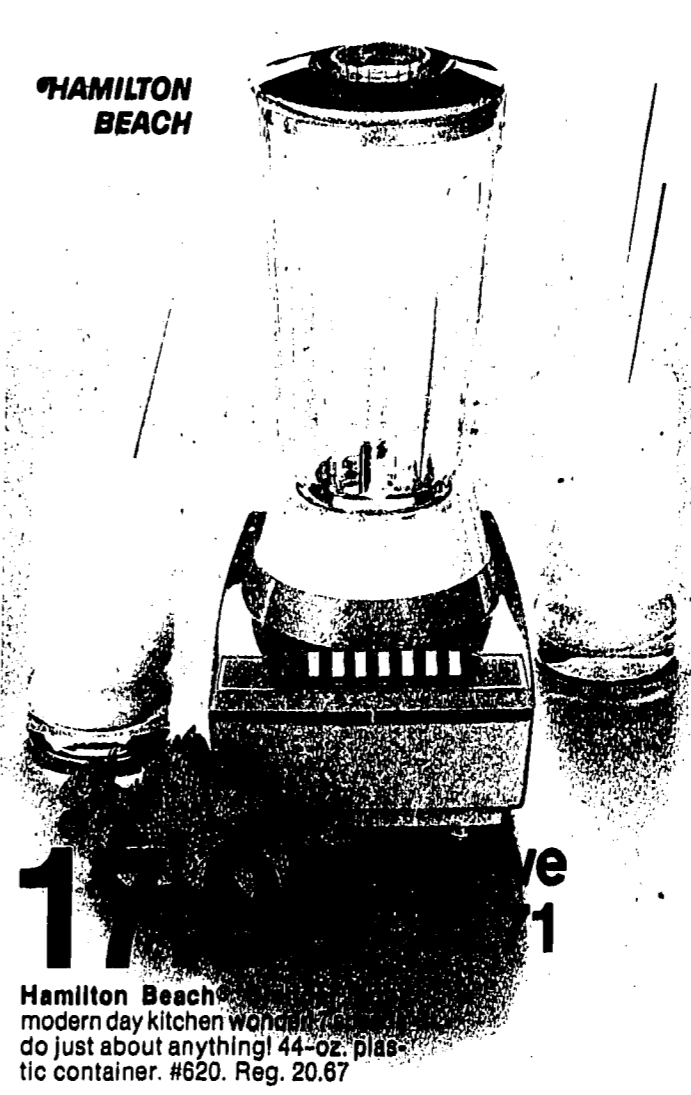

Hamilton Beach® modern day kitchen wrench. Do just about anything! 44-oz. plastic container. #620. Reg. 20.67



9.84

RIVAL® Can Opener Great gift idea! Fast and easy electric opener with Click&Go! Citrus action. Almond or Gold colors. #781. Reg. 11.84



save **19%**
5.67

Chinco® Bread Box Keep your breads fresh and tasty in quaint "Turn of the Century" beautifully lithographed design tin box. Reg. 6.99



save **19%**
5.67

Chinco® Canister Set These additions to your kitchen are perfect for storage! Matching tin boxes of the Century design. #300. Reg. 6.99



1.99

Chinco® Cookie Tin Cookies and snacks are kept fresh longer! Delightful "Turn of the Century" design. Matches canister set and bread box. A nice way to say, "Merry Christmas!"



4.47

Northern® Dry Curling Wand Create lasting curls with gentle heat. Insulated cool tip. A TG&Y best buy! #2321. Reg. 4.99



save **1.80**
15.96

Arvin® Fan-Forced Heater Automatic thermostat, tip-over switch, overload device. 1300 watts. #30H25-01. Reg. 17.76



save **4.00**
15.97

TG&Y AM Radio Full circuit board, plastic cabinet with solid handle. AC/DC battery not included. #E-4541. Reg. 19.97

ONE STORE ONE STOP... for



CHRISTMAS



The grandeur of the "green" at holiday savings that will last!

19.97

Artificial Canadian Pine Tree Bring home the "spirit" of Christmas with the grandeur of this 6' deluxe pine. With 75 full-spreading green branches and 135 tips, it has a full 42" diameter. It's fold-away construction makes for easy storage.



Decorations not included

Items on this page available in all TG&Y Stores

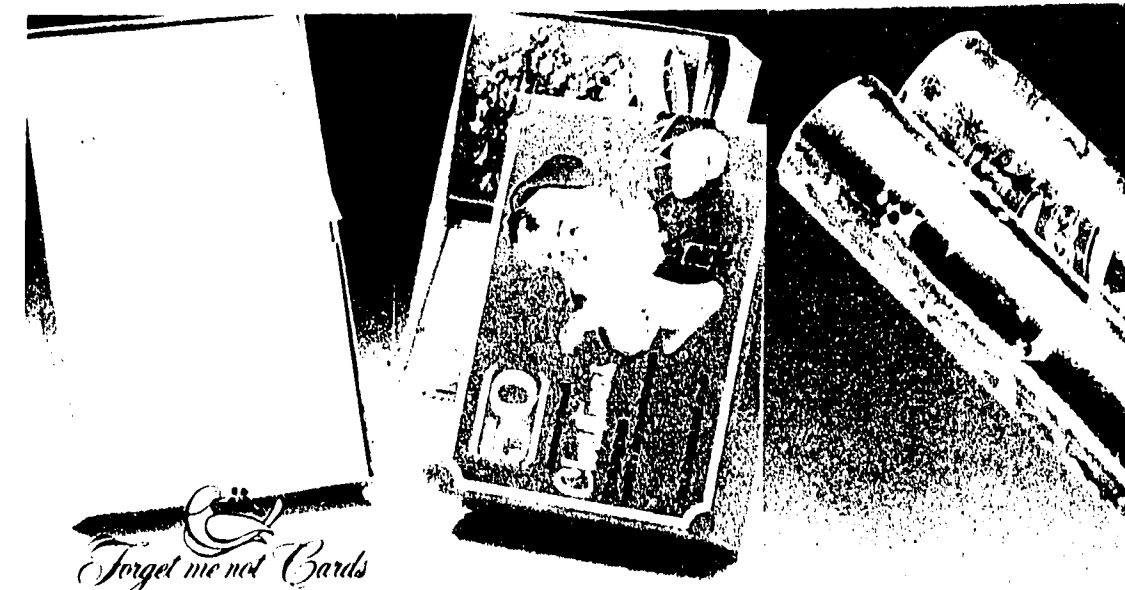

1.00

Forget-Me-Not® Christmas Cards 20 cards in one-design solid pack.

1.97

Christmas Cards Special card assortment. Box of 50 cards with 25 holiday designs.

1.27

30" Jumbo Roll Gift Wrap Heavyweight paper wrap, 50 sq. ft., or foil wrap, 22 sq. ft.



3 FOR 1.00

LePages® Cello Tape Lots of packages to wrap? Get this "best buy" . . . 3 big rolls of tape, 1/2"x1500".

.23

Icicles Add the traditional sparkle to your holiday pine with 1000 shining strands. 18" long.

.99

Deluxe Tinsel Garland Add the adorning touch of a gold or silver color garland! 25'x3" x3 ply. Flame retardant.

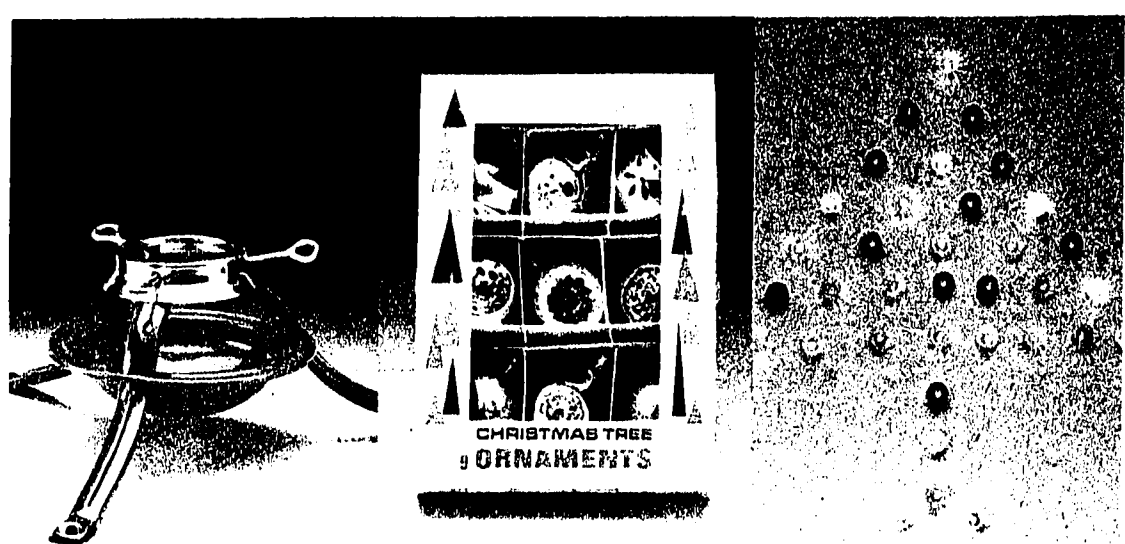

1.67

Tree Stand Secure the season's "green" in sturdy tripod stand. Has rigid ring with 3 1/2" opening.

1.67

Reflector Tree Ornaments Reflection from your tree will add glee to your season! 9 per box. 1 1/2" diameter.

1.99

Mini Light Set 35 multi-color indoor/outdoor, "double-flashing" lights. Replaceable bulbs and push-in sockets.

Yours for the savings... yours for the making!

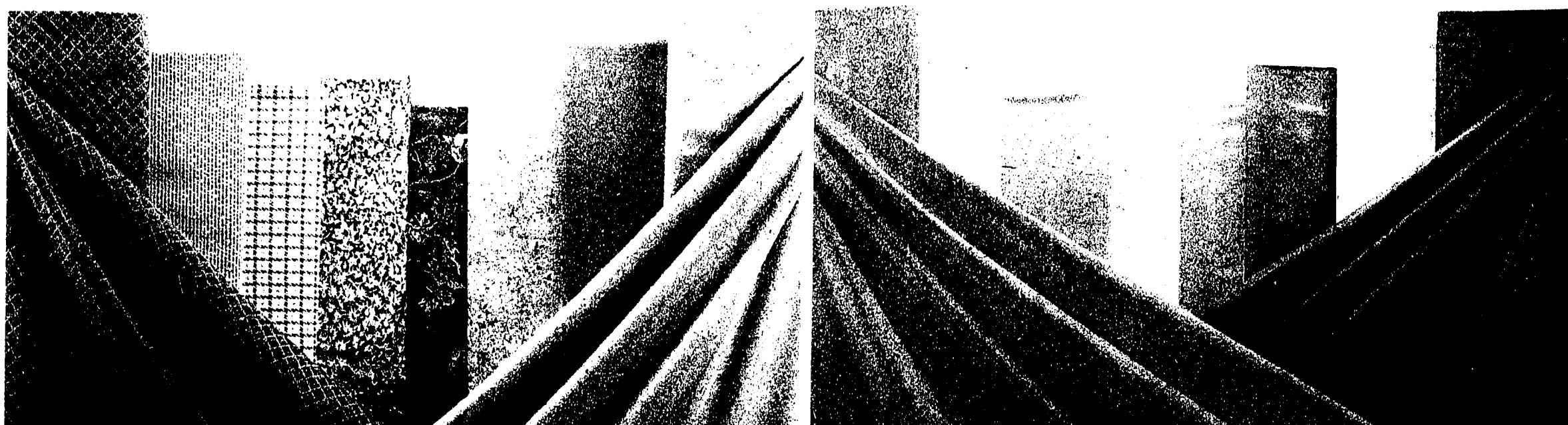

Polyester Knits . . . a super value at TG&Y!

.97 save **38%** yard

Polyester Knits Popular 100% polyester, the utmost in easy-care, designed for comfort and good looks. Prints, plaids or fancies on full bolts, 60/62" wide. Machine warm wash, tumble dry and remove promptly. What a collection of eye-catching colors, beautiful textures! Shop early for this fabric "best buy". Reg. 1.57 yd.

Sheath Lining . . . that finishing touch!

1.77 yard

Polyester Sheath Lining The quality, 100% polyester way to give that outfit a distinctive tailored look. Designed by Stacy Fabrics® on full bolts, 44/45" wide. Machine warm wash, tumble dry and remove promptly. Crease-resistant and static-free. Solids to coordinate with most fabrics. Reg. 1.98 yd.

Give him the warm, western-look flannel shirt and denim jeans at a savings of 13% to 24%!

6.97

save 1.00

Men's Flannel Shirt Comfortably cut, toasty warm! Authentic western plaids of 80% cotton/20% polyester. Long sleeve styling with snap front, 2-pockets and long tail. S-XL. Reg. 7.97



8.97

save 2.91

Men's Western Jean Practical, durable weight 14 oz. blue denim of 65% cotton/35% polyester. Flare leg styling. Stitched pockets bar tacked at all points of stress. Sizes 29-38. Reg. 11.88



'Tis the season for Velour . . .

5.97

Save 1.00 on Boys' Velour Pullover. Choice of 2 long sleeve styles of 80% Celanese Arnel® triacetate/20% nylon in a spectrum of solid colors. 8-18. Reg. 6.97



save 3.00

9.97

Boys' Vest Waterproof nylon shell, 8 oz. polyester filled to fight off the cold! Choice of 2 styles featuring 2 pockets and snap front. Sizes 8-18. Reg. 12.97



25% OFF Regular Price on Men's Sweaters!

Special Group Men's Sweaters Tremendous selection of long sleeve, 100% acrylic pullovers. Your choice of collar styles and colors with contrasting stripes. Sizes S-XL. Regularly 10.97 to 12.88

TG&Y family centers

ONE STORE ONE STOP... for

TG&Y

CHRISTMAS

Items On This Page Good In Family Centers Only

ONE STORE ONE STOP... for

Panasonic



24.97 save 5.00

Panasonic® Cassette Recorder Wrap it up! Features one-touch button for record and built-in condenser microphone. Operates on batteries or AC adapter (neither included). #RQ-44. Reg. 29.97

Panasonic

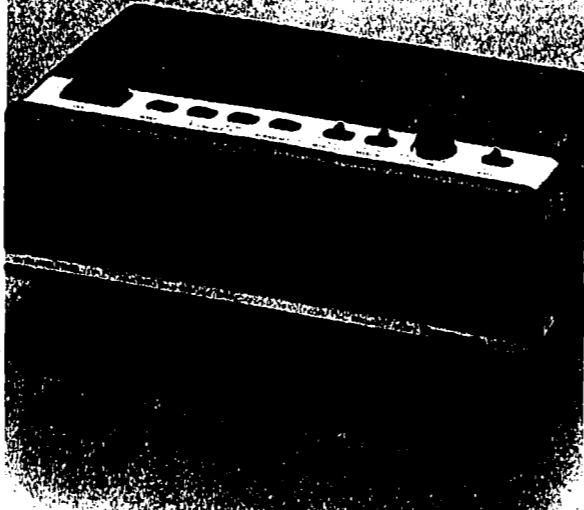

32.88 save 5.09

Panasonic® AM/FM Clock Radio Streamlined design. Features exclusive "Sure Time" battery back-up system (battery not included). Noiseless fluorescent time display, simulated wood-grain cabinet. #RC-76. Reg. 37.97.

Polaroid



Polaroid® One Step automatic camera. Never needs batteries. Add now at even greater savings with this deal from Polaroid! Limit 1

67.93
Money Book Rebate -5.00
Money Book Coupon* -5.00
Your Final Cost **57.93**

*Money Book will be enclosed with Polaroid® rebate check. Additional purchases of Polaroid® products are necessary to receive Money Book benefit.

2.37



Alka-Seltzer® Anti-acid Tablets When you've had just a little too much to eat, take the old "plop! plop! fizz! fizz!" 72 count. Price reflects 25¢ off label.

TOASTMASTER

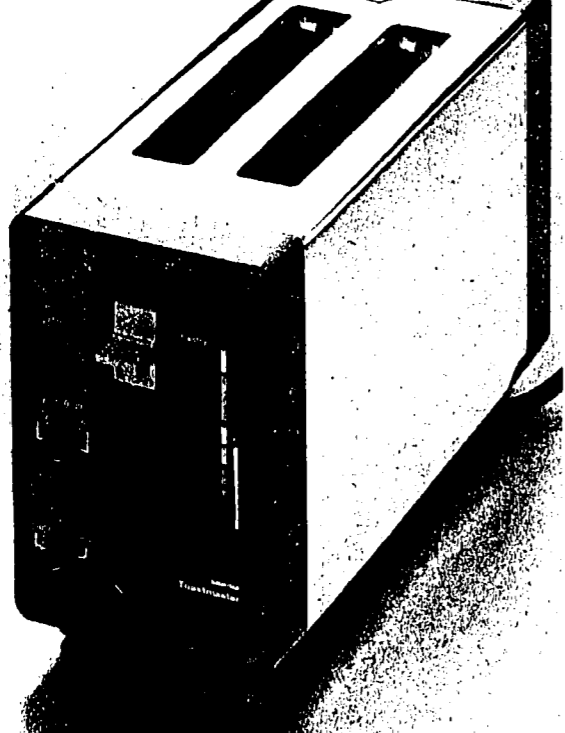

17.96 save 2.00

Toaster Polished chrome 2-slice toaster with setting controls on simulated woodgrain side panel. #B720. Reg. 19.96

Sunbeam

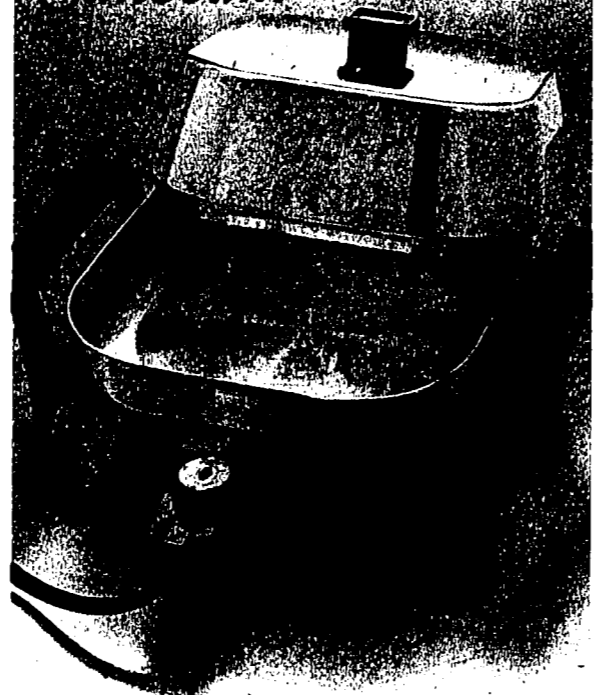

19.99 save 4.89

Sunbeam® Fry Pan Polished exterior. High dome lid... removable heat control plug. 10 1/2" diameter. #7-420. Reg. 24.88

NORTHERN

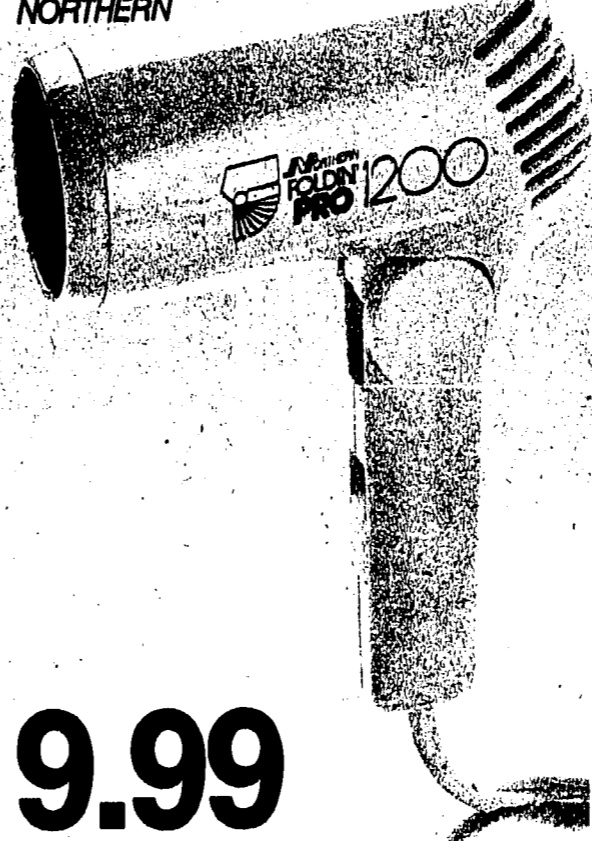

9.99

Northern® Foldin' Pro™ 1200 Blower/Dryer 1200 watt, with two heats and two speeds for drying and styling. Folding handle. #1686

.97



Palmolive® Dishwashing Liquid Made to be gentle to your hands... no worrying about any irritation! 22 oz. bottle.



23.99

Presto® Popcorn Now™ Popper Lets you pop popcorn with hot air—instead of oil! Butters automatically, if desired. #PN1. Limit 1

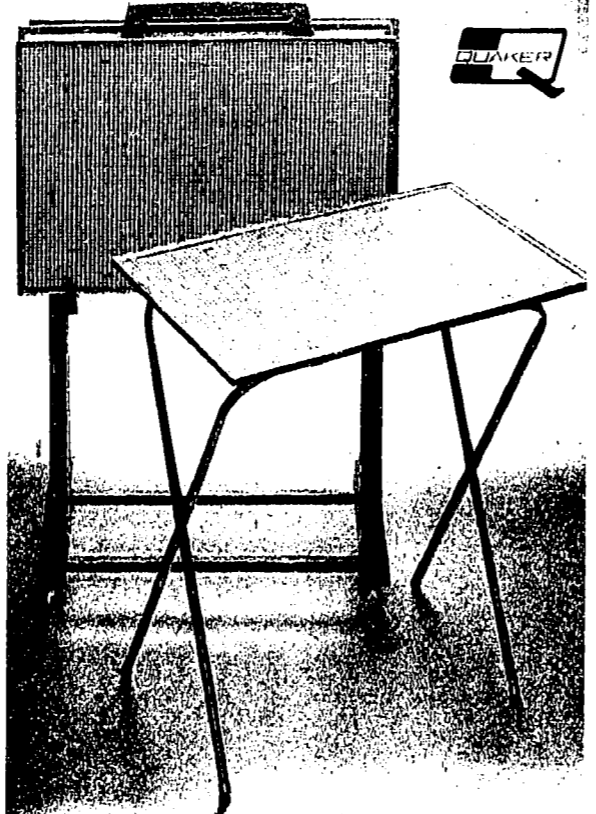

29.99

Folding Set Includes 4 cane-back chairs and storage rack.



19.99 save 3.00

Norelco® Curly Friend™ Dry Hairsetter Gives a professional hair style in minutes! Includes 20 curlers. In compact case. #HB1632. Reg. 22.99

1.27



Woolite® Cold Water Wash Washes better in any fine wash... Washed in Woolite.

TG&Y
family centers

CHRISTMAS