



Monkey business

Not the least of the attractions at the Novi Jaycees' annual Gala Days celebration over the weekend was Jerry the Monkey. But two-year old J.J. Balagna would have been much

happier if Jerry had stayed home and kept his popcorn appetite with him. The Jaycees report a successful Gala Days despite J.J.'s problems with Jerry. (News photo by Steve Fecht)

Ex-super recalls career

By KATHY LAVAY

After calling Novi home for 16 years, a log cabin near Petoskey and a motor home will be home to Tom Dale and his wife Mary, both of whom retired last week from careers in the Novi schools.

Dale came to Novi to serve as superintendent of schools in January of 1966, and his wife, an elementary teacher and librarian, followed him in September. Dale stepped down as superintendent in 1972, and returned to the classroom, where he taught earth science, conservation, geography and Michigan history.

During his tenure with the Novi Schools, Dale has seen changes in almost everything — the district, students and the educational process itself.

In fact, he worked for some of those changes, especially while he was superintendent, a job he wasn't sure he wanted to take on at first.

"I was offered the job in Novi six months before I took it," said Dale. "I had turned it down, but was contacted again by Oakland Schools and the superintendent of public instruction in Lansing. They said 'they (the district) can't agree on anybody else

and we wish you'd take it if you could.'" Dale explained that if Novi had not been able to agree on a superintendent, it would have been split between the Northville and Walled Lake school districts. Convincing the state redistricting commission that Novi was a district worth keeping was a tough initial job.

"My first job was to prove to the state that Novi had some promise for the future," he said. "We did it by population projections and demography.... We showed that the population of Detroit was indeed beginning to move out, and Novi was the last area short of Brighton that had a lot of undeveloped land... people here were supportive and wanted to develop a high school."

Dale said the level of community support for schools in Novi is one thing that has never changed. But other things have.

Today's students, he said, know more than their parents did when they were teenagers, but also seem to have less self-respect and are more concerned with status symbols like driving cars to school.

Teachers, according to Dale, also have changed. The broad, general background that most teachers had 20,

30 or 40 years ago is being replaced by increasing specialization, which may or may not be good.

"We used to hire teachers with two majors, two minors and a minor, four minors... now we get teachers with a strong major and they teach only in that field... it makes it difficult sometimes to connect what one teacher is teaching with what other teachers are teaching."

The educational process itself also has changed. Dale has seen the development of special education programs for learning disabled and handicapped children, which he calls a "change for the better."

And Dale has seen an improvement of academic standards in all classes throughout the schools. "There is more and more high achievement (by students)," Dale said.

In fact, Dale believes the quality of Novi schools is the best it can be.

"The quality of education, the quality of community support of education is second to none," Dale said. How to keep it that way?

"As long as people continue to support schools and have high expectations, those high expectations will be fulfilled."

Novi voters to decide drain issue in August

By KATHY JENNINGS

Drains may be something like electricity — nobody gets excited about them until they don't work.

Faced with facts that the existing drainage system is nearing a stage where people will get excited because it doesn't work, Novi's City Council has decided to ask voters to approve a system of regional-drainage basins.

Voters will be asked in August to approve 1.5 mills for the purpose of developing a coordinated citywide drainage system. The millage proposal includes funds for acquisition of property, construction and maintenance of the system.

Under the proposal going before the voters the city would levy:

- up to one-half mill to maintain a citywide-drainage system;
- up to one-half mill for construction of small detention lakes; and,
- one-half mill to repay an estimated \$4 million in bonds to cover construction of six major drainage projects.

After reviewing a detailed report of the generally poor condition of the existing drainage system from engineer-

ing consultants Mosher-Kapelczak, Inc., the council voted to place the millage request on the August ballot.

If approved, the plan will represent a major redirection in the development of drainage facilities in Novi.

Currently, most individual developments are required to build ponds on their property to hold storm water runoff and control the speed with which it flows from the land.

Under the proposed citywide system, developments will be able to connect to storm water sewer lines, or drains, flowing into regional basins.

Few problems were anticipated when Novi adopted the current drainage system in the late 1960s when Oakland County required all communities to develop standards for on-site detention basins, according to Engineering Consultant Cliff Seiber. At the time they were implemented Novi's standards were considered among the best in Oakland County.

Seiber noted that because communities had little previous experience with detention ponds "it was thought that if you provided an inlet, an outlet and a fence it would go real well." But

as time went on problems with the small on-site basins developed. (See related story).

As a result of problems coordinating and effectively controlling the existing system the council was urged to consider another alternative for controlling drainage citywide.

The council was encouraged to consider that under ultimate development Novi could be dotted with 674 on-site detention ponds, while only 30 ponds will be needed with the regional system.

Novi also could expect "tremendous" maintenance costs if it continues on its current route and nearly 674 basins are constructed, Seiber said.

"The ponds are a tremendous maintenance problem and an ineffective use of property. Ponds may be built in places where there is good buildable property, causing a loss of tax revenue due to the use of buildable land for detention," he added.

Seiber also said smaller ponds have small outlet pipes which are easily blocked with sticks, cardboard and

Continued on 7-A

Schram returns to seat, Henderson wins battle

Incumbent Robert Schram was an easy victor in the race for a four-year seat and Gilbert Henderson narrowly defeated write-in candidate Diana Canup in the race for a one-year term on the Novi Board of Education in Monday's election.

Slightly more than 500 of the districts 10,000 registered voters, not quite five percent, made it to the polls Monday and cast 352 votes for Schram compared to 76 ballots for his write-in opponent Kathleen Mutch in the race for the four-year term.

In the race for a one-year term, Henderson drew 271 votes, while Canup received 198 votes. They were competing for a one-year term created by the resignation of six-year board member Ruth Waldenmayer.

"I hold Diana Canup and her campaign in high regard," Henderson said after his victory. "I'm impressed with her ability to hold a meaningful write-in campaign. It had me worried. It's pro-

ably the best organized campaign I've seen in this town in years."

He added that after the vote totals were announced he was "relieved" and now is "looking forward to being back in that arena and the opportunity to serve young people. I look forward to future interaction with other board members and the administrative staff."

"The first few months are going to be demanding as the district negotiates five contact settlements, and I am confident I can help in that process," Henderson said.

Henderson carried only one of three precincts, drawing the majority of his support from Precinct 3 at Village Oaks Elementary where he received 149 votes in comparison with 64 votes for Canup.

He was defeated by nine votes in Precinct 1 at Middle School South where Canup garnered 38 ballots and he received 29. The candidates were neck-and-neck at Precinct 2 at Orchard Hills

Elementary where 86 votes went to Canup and 82 went to Henderson.

Canup also received 12 write-in votes for the four-year term, for which she was not running. Mutch received six write-in votes for the one-year seat.

In the race for the four-year term Schram took all three precincts by wide margins. Schram is vacationing and could not be reached for a statement on his victory.

He was first elected to the school board in 1978 and served as board vice president and treasurer in 1981.

Henderson ran for office after five years out of local politics. He was first elected to the school board in 1968 and re-elected in 1971 and 1973. He served as board president in 1970-71 and again in 1975. He resigned from the board in 1975 to take office as the mayor of Novi.

The new board members will take office and be sworn in at the school board organizational meeting July 1.

Charter change delayed

Despite earlier indications, Novi voters will not be asked in August to amend the city charter regarding local election practices.

Council members learned Monday that proposed charter revisions they have considered previously cannot be approved in time for the August ballot.

They also decided Monday to revise the charter review process to include citizens. Three council members now serve on the charter review committee.

Previously council members discussed asking voters to approve:

- eliminating some general elections by electing candidates in a primary election;
- removing the option of nomination through payment of a \$100 filing fee; and,
- lengthening the mayor's term from two to four years.

They decided when the measures were first introduced that two of them should be sent to the Michigan Attorney

General for routine review. But the council asked the committee to reconsider the proposal regarding the primary.

Home Starr, a member of the former charter commission, urged the council Monday to leave the charter intact.

"The charter is good as it is," Starr said. "We spent over two years developing it and if you change it now it won't be long before you've torn the limbs off it. Someone will decide they want x-more dollars and they'll be raising (the charter maximum on the number of mills the city can levy.) Soon you'll have just a shell."

Starr urged the council to consider "many people don't know what they are voting for" when charter amendments are put before them.

Council members briefly considered whether the three charter amendments should go before the voters in November, but withheld a decision until they received further information

regarding the length of the ballot.

Council Member Ronald Watson suggested that the council obtain more citizen input regarding the proposed charter changes.

"I would like to see whether we are imposing our interest in this matter," Watson said. "These are candidate-oriented issues and I think we should see what the public thinks."

Mayor Robert Schmid suggested council members were qualified to make such decisions since they have run for office.

"It's ridiculous to have two elections when we have the number of people running that we have had in the past," Schmid said. "Who knows better than the candidates doing it. I am involved and have run, and I think this is a problem for the city. Two elections are expensive and could discourage people from running."

Continued on 7-A

Roethel enters house race

An eleventh-hour declaration pits former Novi Planning Board Chairman John J. Roethel against Novi City Council Member Martha Hoyer in the Republican primary race for the 60th District congressional seat.

Roethel, 62, says he was spurred in his decision to run by the fact that there is no incumbent in the district. "I took a look at the potential candidates and decided I had as much chance as anybody running," he said.

Roethel's candidacy could split the Novi vote between the former mayoral candidate and Hoyer, but Roethel says he feels that Novi candidates should consider the needs of the entire district, not just their own city.

"How much of an effort made by candidates to get votes from other parts of the district will make the difference," said Roethel. "You've got to consider

the whole 60th District."

Roethel points to his long involvement with the Novi planning board and his interest in community activities as qualifications for the congressional seat.

"I'm retired from Ford Motor Company, I have time to put into the job," he said. "I am just interested in community activities.... I've worked with the planning (board) for 10 years."

Roethel says his concerns include inequitable tax structures and conservation of land and natural resources.

"A big part of the 60th District is affected by what the DNR does," he said.

Hoyer and Roethel's competition for the Republican nomination include Highland Township's Willis Bullard, Jr.; John VanDyke of Millford Township; and Allen C. Ingle of Northville.



JOHN J. ROETHEL

Nice going, Novi High School graduates...

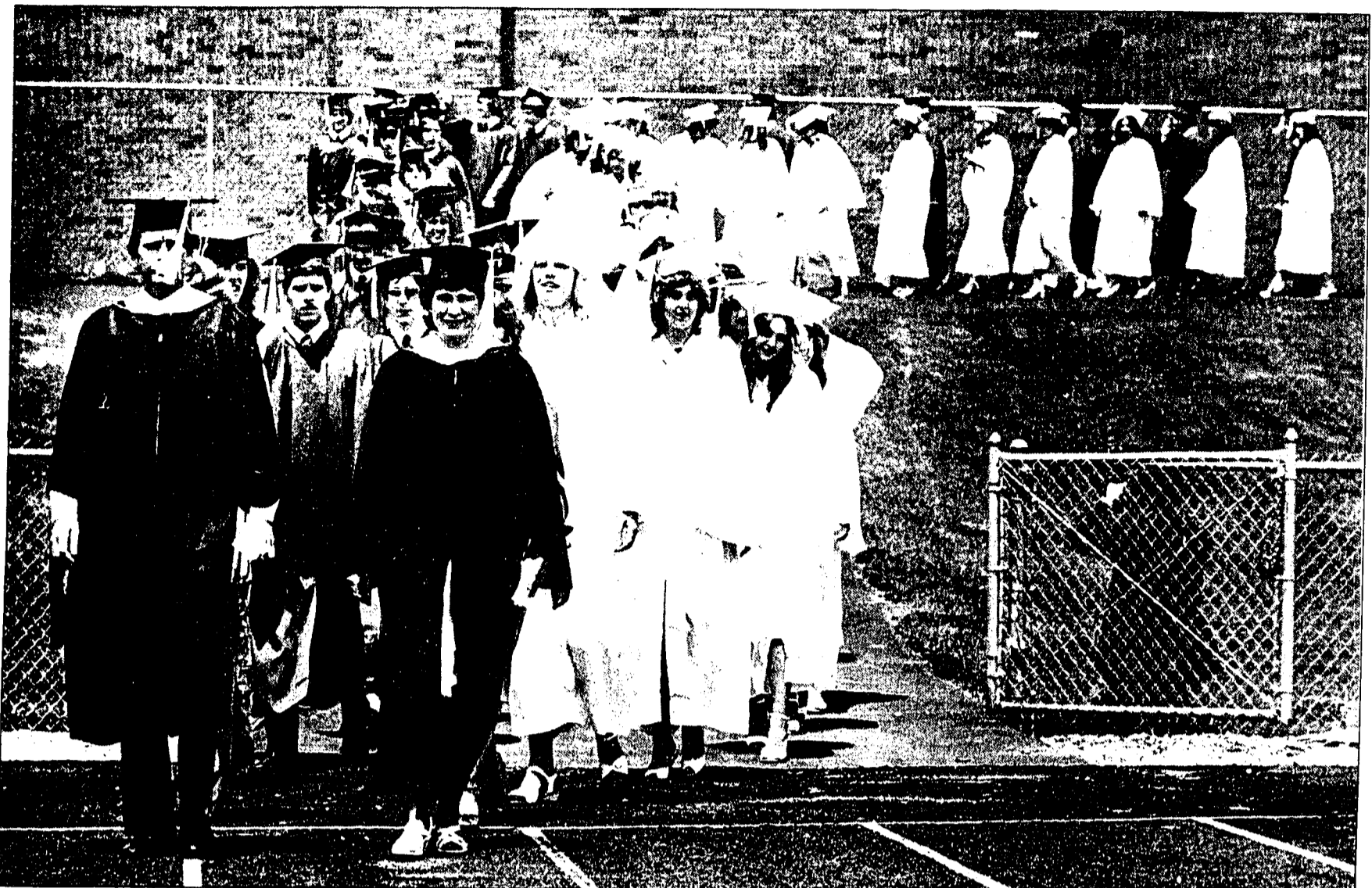

Photos by Steve Fecht



There were cheers and tears, valedictorian and salutatorian speeches, inspiration for the future and plenty of hijinks when Novi High School's Class of 1982 received their diplomas during commencement exercises a week ago Sunday. As valedictorian Sujata Sanghvi and salutatorian Brian Jordan addressed the graduates, members of the Class of '82 were well armed with an assortment of bubble pipes and water pistols.



We congratulate the graduates of 1982

General Filters, Inc.
4380 Grand River
Novi, Michigan 48050
(313)349-2481

Michigan Tractor & Machinery
24800 Novi Road
349-4800

Darling Manufactured Homes
25855 Novi Road
Novi, Michigan 48050
(313)349-1047

FORTEC INC.
Paragon Rail Car Operation
44000 Grand River
(313)349-2451

Novi Feed & Supply
43963 Grand River
(313)349-3133

Novi Auto Parts
43131 Grand River
(313)349-2800

Hook's Jewelry
Novi-Ten Plaza
(313)348-1040

Marcus Glass Co.
25914 Novi Rd.
(313)349-7540

Novi Jaycees & Novi
Jaycees Auxiliary
(313)348-6684

Harold's Frame Shop
44170 Grand River Ave.
(313)349-7750

Section

B

GREEN SHEET

Sliger/Livingston East

Want Ads

INSIDE

Wednesday, June 16, 1982



Tom McGuire (left) gets some hints from his father, John

McGuires keep dairy all in the family

By KATHY LAVEY

John McGuire must be able to make the dairy business look like fun — why else would 11 of his 14 children, several daughters-in-law and three grandchildren (so far) follow him into the family enterprise?

John, the McGuire family patriarch, has been running the Guernsey Farm Dairy in Novi with the help of various family members since 1945, when he and then-partner Fred Russell bought the dairy from J.A. Applehof, after whose herd of Guernsey cows the dairy is named.

McGuire bought out Russell's share of the dairy in 1952 and was left to run it on his own — with a little help from his family.

All seven of McGuire's sons work at the dairy. Jim, Joe and Mike handle retail and delivery of the dairy's products, which include milk, buttermilk and ice cream. Hugh, Marty and Paul are responsible for dairy operations, producing the products that the others sell. And Tom, the oldest, runs the restaurant and ice cream store.

Youngest daughter Karen and her sisters Mary and Lucy handle office work, while sister Rita and sisters-in-law Donna and Mary also do tasks around the office and restaurant.

Not to be left out, three grandchildren, Kris, 15, and Carrie and Rose, both 14, have begun helping out in the dairy — and McGuire expects more to follow as they become old enough.

Family members who don't work at Guernsey must have pretty good excuses — like they live in Florida or Washington D.C. Mother McGuire, who according to her husband has "never worked a day in the dairy," has a special excuse.

"She was too busy raising kids," says daughter Karen.

It seems it would take a lot to keep the family and their employees (about 40 in all) occupied — and if three to four thousand gallons of milk per week, not including cream for ice cream, seems like a lot, then it does.

But the dairy retains the atmosphere of a small, family operation, dealing with small-business customers, and that's what the McGuires want.

The dairy's customers, John McGuire says, still include about 300 home-delivery customers, "lots of small stores and health food stores," restaurants and many area schools, including Northville, Novi, South Lyon and several area parochial schools. The Guernsey Farm Dairy also has a retail outlet in Livonia.

"Stop and buy fresh milk," commands the sign on the front of the dairy on Novi Road, but, McGuire says, fresh milk is not the only specialty available from Guernsey Farm Dairy. Customers can buy the dairy's buttermilk, a "secret" formula purchased two years ago from Frank and Erna Jansen when they retired and sold their popular buttermilk stand on Grand River Avenue in Novi. Those who like ice cream can find variety at the Guernsey

Farm Dairy — the McGuires make more than 50 flavors at different times of the year.

And selling dairy products isn't the McGuire's only occupation — the dairy's restaurant features such specialties as chili and broasted chicken.

McGuire has "always" been in the dairy business — he got started when he went to work for Borden's in 1931. As a dairyman and father of 14, he swears by the nutritional value of milk, and daughter Karen agrees.

"We (the 14 children) drank a lot of it and we're pretty healthy," she said.

McGuire says it just seemed natural that the children would follow him into the dairy business. In fact, he said, younger members of the McGuire family are often anxious to get started. But having so many members of the family employed in the family business surprises him as much as it does anybody.

"I had no idea they would all come here," he said. "But I wouldn't be here if they didn't stay with it... it's kind of nice to have them around."

The Guernsey Farm Dairy is located at 21300 Novi Road, just outside Northville. Hours are 6 a.m. to 10 p.m. Monday through Friday, and 8 a.m. to 10 p.m. Saturday and Sunday.



John McGuire, founder of the Guernsey Dairy, believes in the virtues of hiring relatives. Surrounding him in the restaurant of their Novi Road dairy are (clockwise from left) daughter-in-law Donna McGuire, son Tom McGuire and daughter Karen (McGuire) Kinville. (Photos by Steve Fecht)

Get The Best Garden Tractor Money Can Buy... CASE

10 H.P. Tractor with Mower

- 10 h.p. cast iron Kohler engine
- 4 speed trans. cast iron rear axle
- Lights
- 12 volt electric start
- Weighs 840 lbs.
- Double channel frame

Reg. \$225.00 SALE

\$1995⁰⁰

Model 210 Limited quantities

SAVE \$330

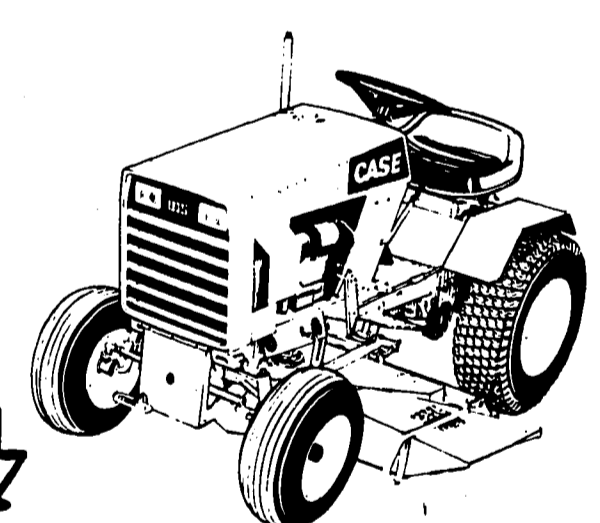

Largest CASE Dealer in the USA for 5 years in a row

There must be a reason! Stop in and see why

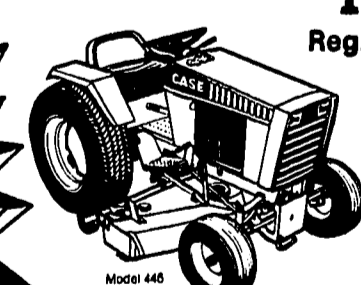

Loader

- Onan cast iron engine, 16.5 hp, 2 cylinder
- Loader lift capacity 650 pounds
- Breakout capacity 1100 pounds
- Overall operating height 7' 9"
- Digging depth 2 inches
- Wheelbase 4 feet
- Overall width 44 inches

Sale

\$4250⁰⁰

Reg. \$5550.00

SAVE \$1300

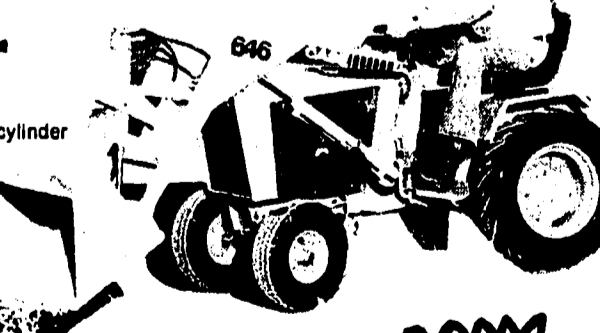

16 H.P. Tractor with Mower

Reg. \$4349.00 Sale

\$3340 SAVE \$1009

One year warranty, parts & labor on all tractors

All other Tractors & Implements on Sale at Big Savings

NEW HUDSON POWER

HOURS: Mon.-Fri. 9-6 Sat. 9-4
53535 Grand River at Haas 2 miles West of Wixom Road 437-1444

Father's Day Specials

with HOMELITE

ST200 String Trimmer / Brush Cutter

Reg. \$219.95 Sale **\$149⁹⁵**

- Heavy Duty reliable 31.1 cc engine
- Heavy duty monofilament line
- Harness and Handle adjustable
- Brush cutter available

HOMELITE RETURN SAW CHAIN SPECIALS

| Reg. | SALE |
|---------------|-------|
| 12" 48L 15.29 | 9.95 |
| 14" 53L 16.79 | 10.95 |
| 16" 59L 18.79 | 11.95 |
| 20" 70L 21.95 | 13.95 |
| 24" 81L 25.79 | 16.95 |

Super Chains (Pre Chain available at reduced prices)

25 foot roll of 3/8 chain \$55.00 Regular or low profile

Bar and Chain Oil

Reg. \$7.95 gal. Sale **\$3⁹⁵** Gal.

PROFESSIONAL Guide Bar Sale

16" Bar (Replaceable Tip) Reg. \$68.00 Sale **\$40⁰⁰**

20" Bar (Replaceable Sprocket Tip) Reg. \$76.00 Sale **\$44⁰⁰**

For models 380, SXL, 150, SEZ, XL12, 410, 550

NEW HUDSON POWER 437-1444

Business Briefs



DARLENE SHEMANSKI, associate broker and sales manager of the Northville-Novl office of Real Estate, has announced that five sales associates ranked in the top 50 sales associates in the company.

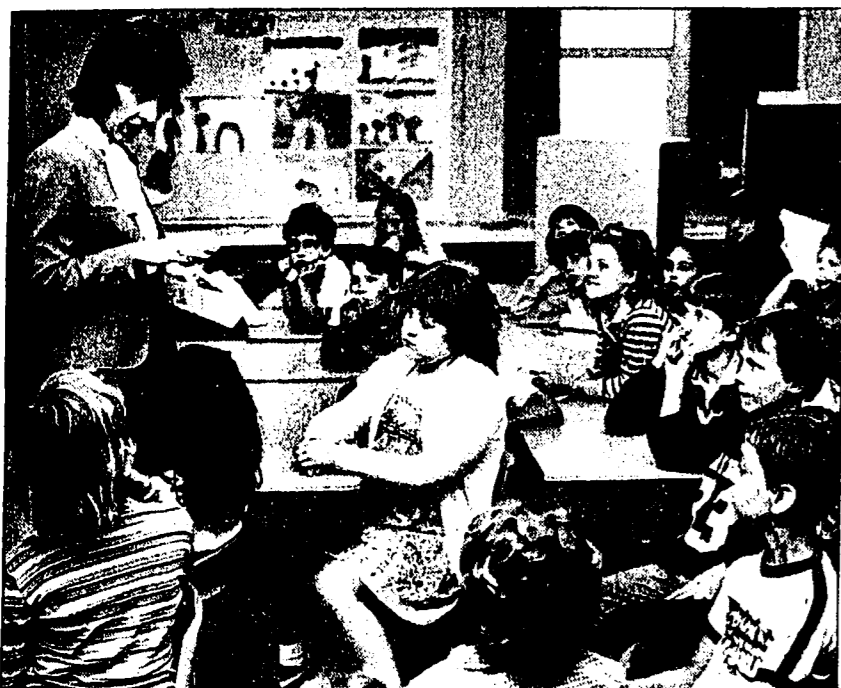

They are (above, left to right) Pat Tassie, Marilyn Pretty, Helen Drysdale, Sharon Serra and Shirley "Mitzie" DeAngelis.

system, received paychecks every Friday for coming to class, and put on a program for their parents, charging admission and splitting the profits.



A new addition to the Plymouth Farmer's Market this year is a Pet Adoption Center for area residents who wish to offer kittens and puppies for adoption.

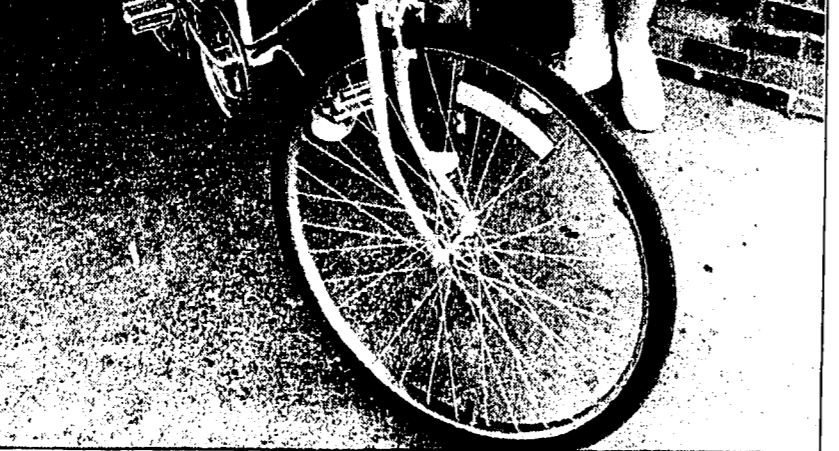

THE WALLED LAKE DAIRY QUEEN offers a lot more than ice cream to its patrons, as Gene Saddler, Jr., found out recently.

ALTERNATIVE LIVING CONSULTANTS for Older Adults is now offering services in Wayne and Oakland counties.

THE FARMER'S MARKET in Plymouth is now open every Saturday from 8 a.m. to 1 p.m. through October 30.

year's farmers, backyard gardeners, home bakers, clubs and local businesses in selling their produce, flowers, trees and shrubs, eggs, cheeses and baked goods.

HEWLETT-PACKARD COMPANY broke ground in Novi June 3 for a new 92,000 square foot zone sales office.

The two-story contemporary structure, located in the 175-acre Orchard Hill Place office park, is scheduled to be completed in the summer of 1983.

Hewlett-Packard Company is headquartered in Palo Alto, California. The firm designs and manufactures computers, electronic test equipment, hand-held calculators, electronic components, medical electronic equipment and instrumentation for chemical analysis.

Lose 20 Pounds by July 4th



32 lbs. Gone... 1 Year Later... I'm still thin! Quick Weight Loss took it off and taught me how to keep it off.

With professional care from our professional staff of Doctors, Nurses and Weight Loss Specialists, you'll lose weight quickly and safely...

SAVE 50% CALL OR DROP IN FOR YOUR FREE CONSULTATION

Super Bargains In Stock Clearance Sale !!!

Table with columns: SALE, Remnants Save 50%, 1/2 off yard goods. Lists various items like Birch Kit, Noation Bag, Sun Blue, etc. with prices.

25% off Tile and Wallpaper Connolly's Carpet CO. 9200 HIGHLAND ROAD (M-56) HARTLAND • 1 MILE W. OF US-23

Red hot peppers spread into home gardening scene

There's such a dramatic contrast between sweet bell peppers and their fiery counterparts, it's hard to believe they're related.

A little goes a long way with the little hot ones, it doesn't take many pepper plants to provide the fire for a full year's eating.

PEPPERS FOR SALADS, PICKLING AND SEASONING

Table listing pepper varieties: Sweet Peppers, Hot Peppers, and their characteristics like color, length, and width.

Table listing pepper varieties: Sweet Peppers, Hot Peppers, and their characteristics like color, length, and width.

New hybrid tomatoes better old varieties

Old flavors don't die, they just fade away. Many gardeners remember "Rutgers" and "Bonny Best" (John Baer) tomatoes fondly, but have discovered recent hybrids surpassing these old standbys in all important characteristics.

At the same time, hybrid vigor has been working to develop superior performance and disease resistance, they haven't forgotten eye appeal.

Heavner Canoe Rental near Milford has...

Now 60 Channels Plus On Your TV Without Cable! Movies, Sports, News and More, 24 Hours a Day \$3495.00

Recommended Tomato Hybrid Chart

Table comparing 'Old standard' tomatoes with 'Suggested hybrid replacement' varieties like Beefmaster VFN, Super Fantastic VFN, etc.

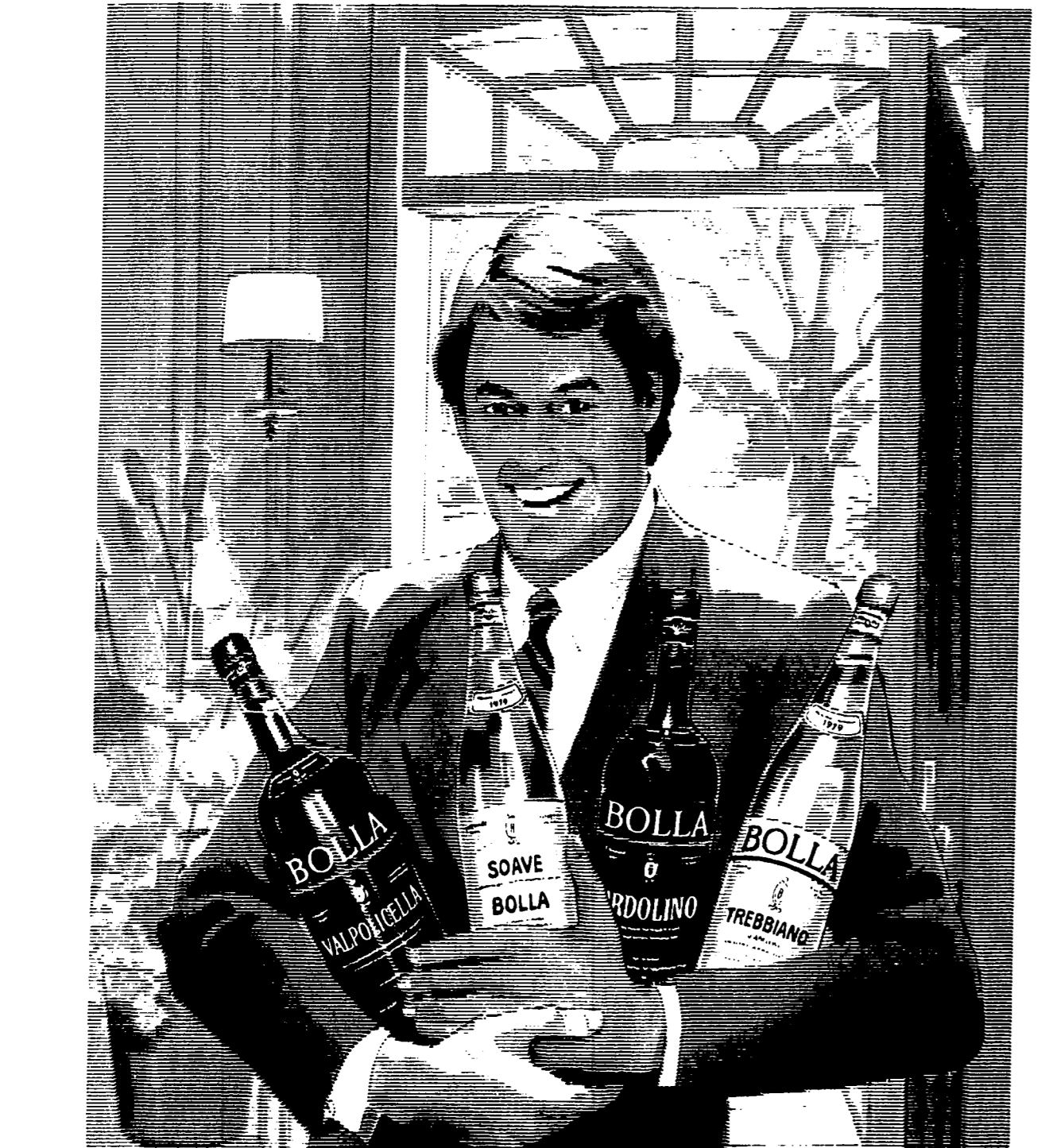

ENJOY WARM RECEPTIONS & MAGNANIMOUS SAVINGS WITH THE BOLLA FAMILY. SAVE \$1.50 ON EVERY MAGNUM OF BOLLA.

FACT: Pick a box of fresh Michigan strawberries today! June is harvest time for nearly 13.5 million lbs. of strawberries our state's farmers grow each year.

Good things growing in Michigan

Then do it yourself! QUICKLY, EASILY, PROFESSIONALLY.

25% off Tile and Wallpaper Connolly's Carpet CO. 9200 HIGHLAND ROAD (M-56) HARTLAND • 1 MILE W. OF US-23

IN-GROUND POOL PACKAGES BEST PRICES AVAILABLE!

PIETILA POOLS 2549 E. Grand River (517) 548-3782

Authentic Weathered Cedar SPLIT RAIL FENCING

NOBLES 8 Mile Supply 28400 W. 8 Mile at Middlebelt 474-4922

DON'T THROW THAT LAWNMOWER AWAY! LET US TUNE UP YOUR LAWNMOWER OR TRACTOR WE DO EVERYTHING FROM MINOR ENGINE REPAIR TO COMPLETE OVERHAUL.

THE GREEN MACHINE Gas powered weed and grass string trimmer. Now On Sale \$169.95

Bolens Sale Save \$100.00 4 H.P. 22" Self-propelled Deluxe Mulching Mower.

Wheel Horse Spring SALE MODEL B-115 with Automatic Trans. \$1895

Highland Outdoor Center 1135 S. Milford Rd. Highland

One local call places a want ad in over 64,000 homes through the following newspapers: Brighton Argus, County Argus/Pinckney Post, County Argus/Hartland Herald, Fowlerville Review, Livingston County Press, Walled Lake News, Northville Record, South Lyon Herald, Milford Times

RATES 10 Words for \$4.25, 23+ Per Word Over 10, Subsequent 3¢ for repeat, Classified Display, Contract Rates Available

Want ads may be placed until 3:30 Monday for that week's Edition. Read your advertisement the first time it appears and report any error immediately. Slips from Newspaper Advertisers Not Issued Credit for errors in ads after the first incorrect insertion.

Want a Bigger Ad? for your garage sale, to sell your home or for any reason. Ask for a GREENSHEET RATE BUSTER. Chose from 3 sizes and get More Attention, More Readers, More Results and a Special Reduced Rate

THE GREEN SHEET 13 Letters & spaces will fit on this line, 12 Letters & spaces will fit on this line, 18 Letters & spaces will fit on this line, 25 Letters & spaces will fit on this line

This Size - \$54 Place your ad in The Green Sheet Classified advertising that reaches 64,000 homes every Wednesday, rain or shine. The paper to read if you have something to sell, need help, or have a garage sale. An ad this size costs \$36

CALL US NOW! 15 Letters & spaces will fit on this line, 24 Letters & spaces will fit on this line, 15 Letters & spaces will fit on this line, 12 Letters & spaces will fit on this line

USE YOUR MASTER CHARGE or VISA Call today and our friendly ad counselors will be happy to help you. Don't be afraid... they are trained to help you. \$72.00 Is what it will cost you to place an ad just like this one in The Green Sheet on Wednesday. The paper that tells you where to go in your local area to find this week's bargains.

Sliger/Livingston Publications GREEN SHEET EAST CLASSIFIED ADVERTISING

absolutely FREE All items offered in this "Absolutely Free" column must be exactly that, free to those responding. This newspaper makes no charge for these listings, but restricts users to residential. Sliger/Livingston Publications accepts no responsibility for actions between individuals regarding advertising. Absolutely Free ads (non-commercial) cooperate in placing your "Absolutely Free" ad no later than 3:30 p.m. Monday for same week publication.

001 Absolutely Free ADORABLE puppy, Shepherd/Retriever, (313)437-8260. 5 Adorable kittens, 2 are grey Angora. (57)746-8810. ADORABLE FREE kittens. Call (313)272-4202.

010 Special Notices SYNOPSIS for smoking, stress, job loss, etc. (313)729-2200 or (313)697-7348. Universal Self-Help Center, Westland.

016 Found BLACK litter Setter-type male, 11 weeks, (313)878-8988. FOUND: 3 month Beagle near 22nd and Genoa. (313)878-7245.

DON'T WAIT UNTIL MONDAY! You can place your ad any day of the week, including Saturday and Sunday. GET HEAD OF THE CROWDS, CALL NOW

UNIQUE HISTORIC CHARMING! Outstanding brick residence dating back to 1864, in excellent condition! Set on 2 beautiful, tree doted acres. This home offers a delightful privacy within minutes of Brighton. CALL FOR APPOINTMENT - \$125,000.

021 Houses For Sale OPEN HOUSE SUNDAY 10 AM-12 PM. Pinkney, by owner. 3015 Monks Road, corner of Cedar Lake Road. (313)876-8400.

021 Houses For Sale WALLED LAKE. Rent with option to buy. 2 bedroom, fireplace, basement, faces lake. (313)876-8400.

021 Houses For Sale WALLED LAKE. Rent with option to buy. 2 bedroom, fireplace, basement, faces lake. (313)876-8400.

021 Houses For Sale WALLED LAKE. Rent with option to buy. 2 bedroom, fireplace, basement, faces lake. (313)876-8400.

021 Houses For Sale WALLED LAKE. Rent with option to buy. 2 bedroom, fireplace, basement, faces lake. (313)876-8400.

021 Houses For Sale WALLED LAKE. Rent with option to buy. 2 bedroom, fireplace, basement, faces lake. (313)876-8400.

021 Houses For Sale WALLED LAKE. Rent with option to buy. 2 bedroom, fireplace, basement, faces lake. (313)876-8400.

021 Houses For Sale WALLED LAKE. Rent with option to buy. 2 bedroom, fireplace, basement, faces lake. (313)876-8400.

021 Houses For Sale WALLED LAKE. Rent with option to buy. 2 bedroom, fireplace, basement, faces lake. (313)876-8400.

021 Houses For Sale WALLED LAKE. Rent with option to buy. 2 bedroom, fireplace, basement, faces lake. (313)876-8400.

021 Houses For Sale WALLED LAKE. Rent with option to buy. 2 bedroom, fireplace, basement, faces lake. (313)876-8400.

021 Houses For Sale WALLED LAKE. Rent with option to buy. 2 bedroom, fireplace, basement, faces lake. (313)876-8400.

025 Mobile Homes MILFORD. 1972 Cambridge, 3 bedrooms, \$1,000 down. Terms. (313)876-8400.

025 Mobile Homes MILFORD. 1972 Cambridge, 3 bedrooms, \$1,000 down. Terms. (313)876-8400.

025 Mobile Homes MILFORD. 1972 Cambridge, 3 bedrooms, \$1,000 down. Terms. (313)876-8400.

025 Mobile Homes MILFORD. 1972 Cambridge, 3 bedrooms, \$1,000 down. Terms. (313)876-8400.

025 Mobile Homes MILFORD. 1972 Cambridge, 3 bedrooms, \$1,000 down. Terms. (313)876-8400.

025 Mobile Homes MILFORD. 1972 Cambridge, 3 bedrooms, \$1,000 down. Terms. (313)876-8400.

025 Mobile Homes MILFORD. 1972 Cambridge, 3 bedrooms, \$1,000 down. Terms. (313)876-8400.

025 Mobile Homes MILFORD. 1972 Cambridge, 3 bedrooms, \$1,000 down. Terms. (313)876-8400.

025 Mobile Homes MILFORD. 1972 Cambridge, 3 bedrooms, \$1,000 down. Terms. (313)876-8400.

025 Mobile Homes MILFORD. 1972 Cambridge, 3 bedrooms, \$1,000 down. Terms. (313)876-8400.

025 Mobile Homes MILFORD. 1972 Cambridge, 3 bedrooms, \$1,000 down. Terms. (313)876-8400.

025 Mobile Homes MILFORD. 1972 Cambridge, 3 bedrooms, \$1,000 down. Terms. (313)876-8400.

061 Houses For Rent
HOWELL, Country 4 bedroom home, fully carpeted 5500 per month. Security deposit. \$1754-1724.
HAMBURG, 3 bedroom with water privileges. Available July 6, 4400 monthly. (313)331-3672.
HOWELL, Triangle Lake frontage, furnished, 3 bedrooms, fireplace. (313)326-2126.
MILFORD, 1 bedroom home near Proving Grounds, \$250 per month. (313)546-3473.
MILFORD, 2 bedroom, 2 story on 2 acres, wooded and secluded. Great for kids. \$600 plus utilities. (313)655-3455.
MILFORD, For rent with option to buy. Four bedroom home overlooking Kensington park, four acres. \$550 per month. (313)655-7759.
NORTHVILLE, home 3 plus bedrooms. \$450 per month. After 5 p.m. (313)346-6250.
After 4 p.m. (313)346-3076.

061 Houses For Rent (continued)
NORTHVILLE, 3 bedroom home. Nice lot. \$420. (313)346-3662.
NORTHVILLE, 3 bedroom home. Call James C. Salomon. (313)437-8171.
WHITMORE Lake, Practical three bedroom ranch. \$385 monthly. (313)346-4030.
PICKNEY, 3 schools, 4 bedrooms, 2 1/2 baths, family room, dining room, fireplace. Available now. \$469. (313)346-7000.
NORTHVILLE area, 3 bedroom, four horse barn. \$500 monthly. (313)346-5287.
NORTHVILLE, 3 bedroom home located in town. Walking distance to school and stores. \$350 a month plus \$350 security deposit. After 4:30 p.m. (313)346-2961.
NORTHVILLE, 4 bedroom home, walking distance to school. \$425 per month. Call garden area. (313)453-4300.
062 Lakeside Houses For Rent
BRIGHTON, 2 bedrooms, 2 baths with full kitchen. \$350 monthly plus security. (313)327-4500.
BRIGHTON, 2 bedrooms, 2 baths with full kitchen. \$350 monthly plus security. (313)327-4500.
HARTLAND, 2 bedroom, full kitchen. \$350 monthly plus security. (313)327-4500.
064 Apartments For Rent
BRIGHTON, Extra large 1 bedroom apartment with private entrance on 2 acre overlooking pond. Heat included. \$275. (313)227-2265.
HOWELL, HILLS HILLS PHASE II, Large 1 - 2 bedrooms, from \$226. In-unit heat, appliances, security system, laundry and pool. (313)745-7680.
HOWELL, HILLS HILLS PHASE II, 2 bedrooms, modern units, \$250 up, fully equipped. (313)745-7680.
BRIGHTON, 2 bedroom apartment, \$280 monthly, heat included. (313)346-8239.
BRIGHTON, 2 bedroom apartment, \$280 monthly, heat included. (313)346-8239.
064 Apartments For Rent (continued)
HOWELL, 2 bedroom apartment, \$280 monthly, heat included. (313)346-8239.
BRIGHTON, 2 bedroom apartment, \$280 monthly, heat included. (313)346-8239.
064 Apartments For Rent (continued)
BRIGHTON, 2 bedroom apartment, \$280 monthly, heat included. (313)346-8239.
064 Apartments For Rent (continued)
BRIGHTON, 2 bedroom apartment, \$280 monthly, heat included. (313)346-8239.

ONLY MINUTES FROM WHERE YOU WORK
Livonia • Brighton
Plymouth • Farmington Hills
Farmington Hills
Southfield • Ann Arbor

Beautiful 2 & 3 Bedroom Apartments from \$225
HEAT INCLUDED • 6 MONTH LEASES AVAILABLE

THE VILLAGE IN WILKOM
Corner of 9 Mile and Pontiac Trail
Open Daily 9 to 6
Phone 437-1223

CREST MOTEL
Special summer rates on apartments, cottages and sleeping rooms. Completely furnished. (313)745-1232.

INSBROOK AT NORTHVILLE
Spacious apartments with private balcony or patio, swimming pool, tennis court & club house with sauna.

ALWAYS THE LEADER COUNTRY FAIR
National's Largest Inside Markets
Has 2 Big Locations
2046 Dieck Hwy, End of Telegraph
Open Daily 9-5 for dealer reservation

HOUSEHOLD SERVICE AND BUYERS DIRECTORY

ADVERTISERS LISTING: Air Conditioning, Asphalt, Brick, Block, Cement, Building & Remodeling, Bulldozing or Excavating, Carpentry, Ceramic Tile, Engine Repair, Heating & Cooling, Landscaping, Moving and Storage, Painting & Decorating, Plumbing, Roofing & Siding, Wallpapering, Welding, etc.

240 Automobiles

1973 Grand Prix. Runs good, power steering, power brakes, power windows, automatic, cruise, air-m/fm stereo, very good condition, no rust, \$2,500. (313)227-4959 after 5 p.m.

1975 Granada. 6 cylinder, automatic, cruise, air-m/fm stereo, very good condition, no rust, \$2,500. (313)227-4959 after 5 p.m.

1977 Horizon TC-3. Automatic, air-m/fm, rear defroster, new tires, clean, \$3,150. 1975 Honda CB-200. (313)437-8554.

1973 Impala Chevrolet. Power brakes, steering, air-conditioning. Very little rust, \$1,000. (313)546-8285, 4825 Brody Road, Howell.

JACK DEMMER
REBATES CONTINUE
'82 ESCORT
2 door, full standard factory equipment.
\$4995
from
Plus taxes, title & destination charges
OVER 100 AVAILABLE
at Similar Savings
•ALSO REBATES ON EXP'S
FREE 24 month/24,000 mile Ford Care Maintenance & Warranty on Select Models
A, X, Z PLANS WELCOME - TOP DOLLAR FOR ALL TRADES
JACK DEMMER FORD 721-2600
Michigan Ave. at Newburgh (Just e. of I-275)

240 Automobiles

1977 Grand Prix. Landau top, power steering and brakes, automatic, cruise, air-m/fm stereo, very good condition, no rust, \$2,500. (313)227-4959 after 5 p.m.

1975 Granada. 6 cylinder, automatic, cruise, air-m/fm stereo, very good condition, no rust, \$2,500. (313)227-4959 after 5 p.m.

1977 Horizon TC-3. Automatic, air-m/fm, rear defroster, new tires, clean, \$3,150. 1975 Honda CB-200. (313)437-8554.

1973 Impala Chevrolet. Power brakes, steering, air-conditioning. Very little rust, \$1,000. (313)546-8285, 4825 Brody Road, Howell.

JACK DEMMER
REBATES CONTINUE
'82 ESCORT
2 door, full standard factory equipment.
\$4995
from
Plus taxes, title & destination charges
OVER 100 AVAILABLE
at Similar Savings
•ALSO REBATES ON EXP'S
FREE 24 month/24,000 mile Ford Care Maintenance & Warranty on Select Models
A, X, Z PLANS WELCOME - TOP DOLLAR FOR ALL TRADES
JACK DEMMER FORD 721-2600
Michigan Ave. at Newburgh (Just e. of I-275)

LIVINGSTON COUNTY'S NUMBER ONE USED CAR DEALER
—THIS WEEK'S SPECIALS—
1974 Jeep CJ-5
Hard Top
ONLY \$1295.00

1980 CAPRI 3-DR.
4 cyl., 4 speed, stereo, rear defroster, Like New **ONLY \$4895**

1979 MARQUIS BROUGHAM 2-DR.
V-8 auto., air, P.S., P.B., full power, tilt wheel, cruise control, fu-tone paint, stereo, Very Sharp **ONLY \$4995**

1979 MERCURY MONARCH 2-DR.
6 cyl. auto, air, P.S., P.B., radio. Nice Car. **ONLY \$3875**

1977 CHEVROLET PICK-UP
V-8, 4 speed, P.S., P.B., stereo, mag wheels. Good condition. **ONLY \$2495**

1976 FORD TORINO 2-DR.
V-8 auto, P.S., P.B. **ONLY \$495**

1977 FORD F-250 PICK-UP 4x4
V-8, 4 speed, P.S., P.B. ONLY **\$2395**

1979 BUICK RIVIERA SPORT COUPE
V-6 turbo, air, moon roof, P.S., P.B., p. windows, P. seat, P. locks, tilt wheel, cruise control, wire wheels, velour trim. Perfect Cond. **ONLY \$8295**

1980 T-BIRD
V-8 auto, P.S., P.B., stereo, vinyl top. A Steal at **ONLY \$3995**

— WE BUY CARS —
TOP \$\$ FOR CLEAN CARS
LOW DOWN PAYMENTS INSTANT FINANCING
HILLTOP FORD & MERCURY
At The Top Of The Hill
NOWELL OPEN SAT. 848-2250

FACTORY CASH BACK

'82 ESCORT Hatch, sport colored paint, black interior, air, stereo, power windows, radio, fog lights, rear wiper, 5 sp. No rust. **\$4949**

'82 EXP Hatch, sport colored paint, black interior, air, stereo, power windows, radio, fog lights, rear wiper, 5 sp. No rust. **\$1748**

SPECIAL FACTORY SAVINGS on all
• Mustangs
• Thunderbirds

120 ESCORTS in Stock
Stop in and Browse

• Buy or Lease
• A, B, X, Z Plans Welcome
Open Monday & Thursday 'til 9 p.m.

McDonald Ford Farm
550 West Seven Mile Rd.
349-1400 Northville 427-6650

Dollar Power
NOBODY SELLS FOR LESS!

1982 ESCORT 3 Door
Front Wheel Drive - Full factory equipment
PRICED FROM \$4989
FREE 24 Month/24,000 MILE MAINTENANCE AND WARRANTY ON: EXP and ESCORT
HIGHEST \$\$\$ TRADE-IN!

1983 RANGER PICKUP
PRICED FROM **\$5545***
F-SERIES PICKUP
PRICED FROM \$5789*
IMMEDIATE DELIVERY

ASK ABOUT OUR NO MONEY DOWN LEASE PURCHASE PLAN

Varsity Ford
3480 Jackson Rd. at Wagner Rd. PHONE: 996-2300
Open Mon. & Thurs. 9-9 Tues., Wed. & Fri. 9-6 Saturday 9-5
*Includes Rebate Plus Transportation, Taxes and License.

Living
NOVI-WALLED LAKE NEWS
Wednesday, June 16, 1982

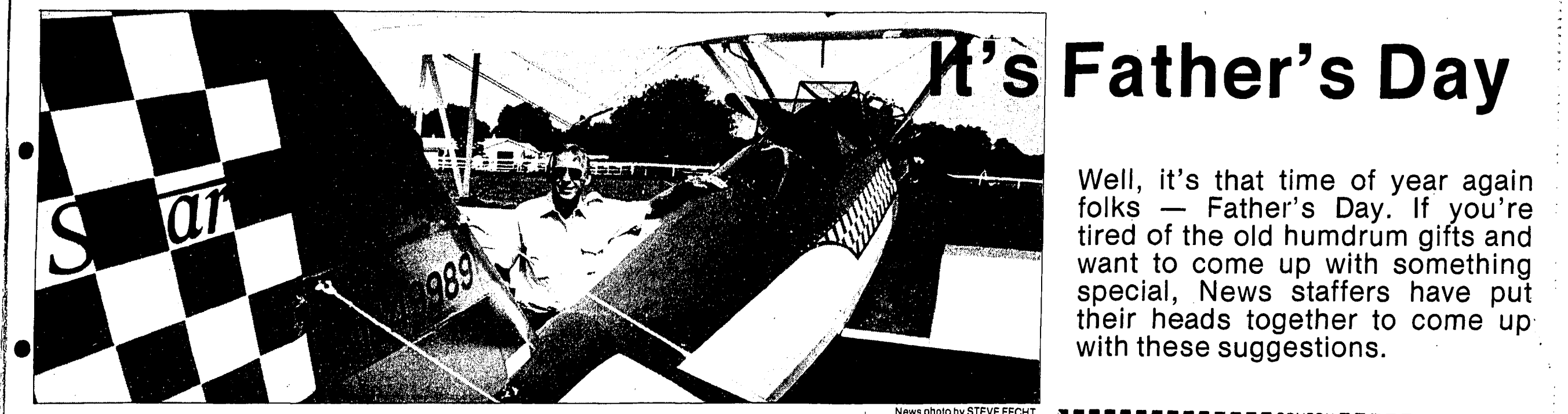

Lou Spanberger is ready to take Dad up for a trip in a biplane. News photo by STEVE FECHT

CITIZEN Father's Day Gifts

The Time-Track No more second hand, but in its place is an LCD second band that precisely counts and records each second as it travels. Its display includes hours, minutes, day/date, alarm, hourly chime, countdown timer, chronograph.

NOVI-TEN PLAZA
41690 W. 10 Mile 348-1040
Established 1948 25 years experience

HOOK'S JEWELRY, INC.

IV SEASONS FLOWERS

149 E. Main Northville 349-0571

FAMILY DENTISTRY
Dr. Jesse Grimm

- Post Instructor U of M. U of D Dental School
- Maintains Continuing Education
- Serving the community over 13 years some location
- Member ADA, MDA
- Affordable dentistry

349-7560
1055 Novi Rd.

Father's Day Sale
Special on Blank Video Tapes

Hitachi T-120 **\$12.99**
Fuji T-120 **\$13.99**
Sony L-500 **\$11.99**

Sale ends June 21st

Also Available:
Defender Chopper Command Demon Attack Star Master **\$28.00**

Located in West Oaks Mall
across from Twelve Oaks
Novi • 348-4111
Mon.-Sat. 10-9 Sun. 12-6

VIDEO WHEREHOUSE

Countryside Landscaping Inc.
43230 W. Seven Mile Rd.
across from Highland Lakes Shopping Center
Northville 348-1844
Hours: Mon.-Sat. 9 a.m.-7 p.m., Sun. 10 a.m.-5 p.m.

Complete Landscaping Construction

Free Estimates

- Custom Designs
- Retaining Walls
- Decks
- Patios (Brick & Wood)
- Automatic Sprinkler Systems

Stop by our nursery and browse through our quality shrubs, trees and flowers. Our helpful and courteous sales people are happy to assist you with any of your landscaping needs.

Weekend Special!!
June 18, 19 and 20
All Annuals..... \$5.95 Flat
Geraniums..... 99¢ Each
4 1/2" Pot..... or \$12.95 For 15 pots

SUPER SOFA SAVINGS. Values To \$1190. Now \$695.

Flexsteel sofas are known for quality. Their springs are guaranteed - in writing - for a lifetime. Frames are kiln dried hardwood. Joints are glued, screwed, and blocked.

And we've got 3 of our best Flexsteel sofas at 30 to 40% off. All feature fashionable nylon, polyester, or Herculon fabrics. And for one week, you can buy them for only \$695 each.

Plymouth Furniture
360 S. Main St./Plymouth, Michigan
455.5700/Open Thurs. Fri. 9am to 9pm.
Mon. Tue. Wed. Sat. 9am to 6pm.

It's Father's Day

Well, it's that time of year again folks — Father's Day. If you're tired of the old humdrum gifts and want to come up with something special, News staffers have put their heads together to come up with these suggestions.

Forget the Ties and Slippers This Year!!
GIVE DAD A GIFT HE WILL NOT WANT TO RETURN
Father's Day June 20th
SEND HIM A "Belly Gram"

A dancing special delivery for all occasions

- GRADUATIONS
- BIRTHDAYS
- ANNIVERSARIES
- RETIREMENTS
- PROMOTIONS
- OR THAT SPECIAL PICNIC OR LUNcheon

BELLY GRAM SERVICES NATIONWIDE and CANADA
INC. CALL Lansing (517)349-2867
COUPON

Yet another tie. Still another pipe. More socks, more shirts, more handkerchiefs. A "nice" pen, a letter opener. Cuff links. These are the things that no man needs, yet the third Sunday of every June, many fathers get them — as gifts, from people who should know better.

"But we had to get him something," protest the loving but unthinking families who make tie and handkerchief manufacturers richer by the year. "He can always use another pair of socks (cuff links, pipe, pen, handkerchiefs)." Sure, he can use another pair of socks (cuff links, pipe, pen, handkerchiefs), but wouldn't he prefer something else?

For those who realize they're in a Father's Day rut and would like to do something different this year, we offer the following list of suggestions, activities with which to indulge your paternal unit. They're a little expensive, but we figure Dad deserves it after years of traditional, useful gifts.

If you've already bought a more mundane present, or think your Dad needs a year to get used to the idea of doing something different after all those safe, useful presents of years past, or if you just can't come up with the cash this year, keep these ideas in mind and save your money — for next Father's Day.

For daring Dads, how about an aerobatics ride in an open cockpit biplane? They're available at New Hudson Airport.

According to Lou Spanberger, part-owner and manager of the airport, a half-hour aerobatics ride in the open cockpit biplane cost \$40 for 15 to 20 minutes in the air.

During the "Daring Dad" ride in the two-seated biplane, Spanberger performs barrel rolls and various other airplane tricks. Although the ride is short, Spanberger assures that any longer in the air is more than the novice can take.

For more sedate Dads, Spanberger offers a scenic ride in the biplane. At a cost of \$20, it lasts about half an hour, enough time for Dad to take a leisurely look around.

If you'd like to go too, general Motors are also available in a four-seated airplane at a cost of \$10 per person for a 20-minute ride that includes views of area lakes, Camp Dearborn and the scenic rides proving grounds at Milford.

If Dad's a camera buff, the airport also offers "photography runs." Spanberger will take Dad and his equipment to buzz your neighborhood and photograph your house, or get aerial shots of just about anything else Dad can think of at a cost of approximately \$30 per half hour.

Reservations aren't necessary, but Spanberger encourages potential flyers to call the New Hudson Airport ahead of time at 437-2333.

If you really want to show Dad the "Royal Treatment," and price is no object, then renting a chauffeur-driven limousine for the day is the present you've been looking for.

Dorothy Golob, manager of Detroit Limousine Service at 36600 Almond in Farmington Hills, says Dad's favorite newspaper can be waiting for him in the car when he arrives home.

And if you'd rather take Dad to lunch, a chilled bottle of champagne will show him you think he's special.

Since there is no mileage when the limousine is driven locally, be sure to have the chauffeur too slowly through the neighborhood several times so everyone can see him in his Father's Day limo.

Dad's worried that the limousine service won't know how to treat your favorite father.

"We do this on a regular basis," says Golob. "A lot of wives rent limousines for their husbands, to drive them to the office and they have his favorite donuts ordered. Then they meet him after work and go out to dinner."

All the limousines are chauffeur-driven.

Driving Dad out in style will cost \$85 for the first two hours and \$25 for each additional hour.

Call Detroit Limousine Service at 582-3733.

Okay, not all unusual Father's Day gifts have to be expensive and, if your Dad's the open-minded type, you can have one heckuva time by taking him down to the local arcade and introducing him to the joys of Pac Man.

Arcade? Pac Man? You say your Dad wouldn't be caught dead playing Pac Man in an arcade?

Well, it's time he learned. You'll have to judge just how resistant he is. And, if he's super-resistant, you just might have to announce that you've planned a "mystery trip" for him on Father's Day.

Once he gets there, however, he might be surprised to find that arcades aren't necessarily hangouts for teeny-boppers. There may even be a few three-piece suit types who will make him feel under-dressed.

And once you've gotten that first quarter in the machine, the battle's over. Just wait till he chases those little blue ghosts around the maze once or twice.

We said this was a cheap gift. But it might not be. Be armed with a goodly number of quarters in advance just in case Dad comes down with a severe case of Pac Man fever.

Of course if that happens, you may be the long-range beneficiary as dear old Dad just might go out and get you one of those Pac Man games to have in the home.

Supplement to June 16 Detroit News, Oakland Press, Ann Arbor News, Ypsilanti Press, Southern Michigan Newspapers Inc./Observer Eccentric/Sigir, The Daily Tribune

8 PAGES BRIMMING WITH VALUES THROUGHOUT THE STORE!

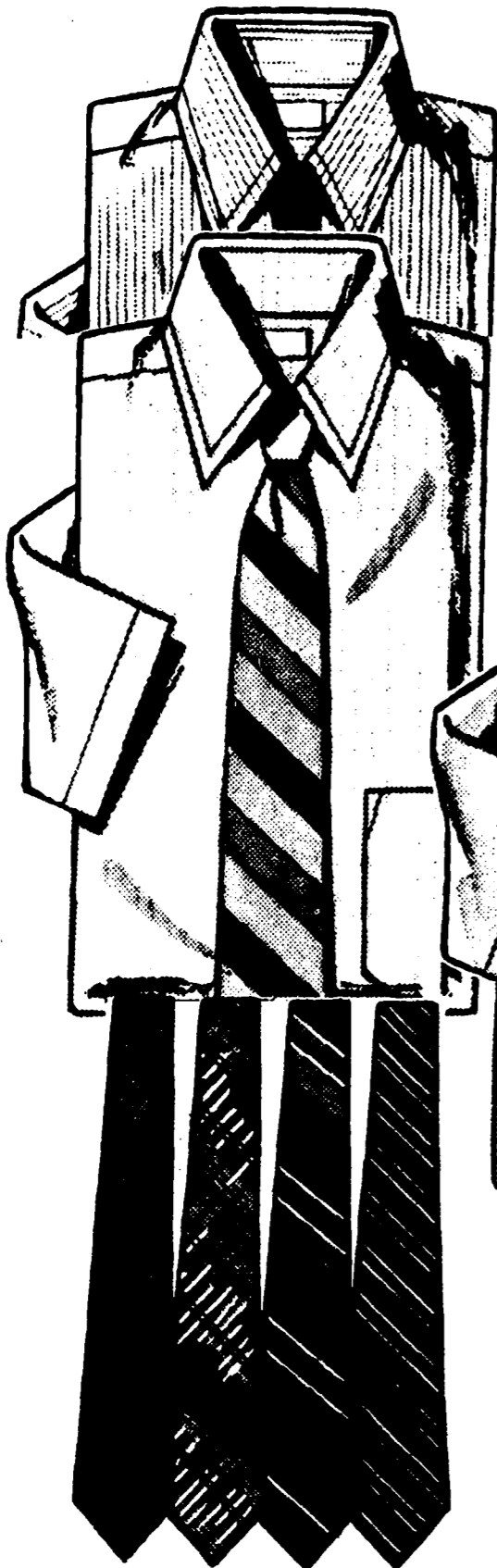

**40% OFF
Men's dress shirts**

Revitalize your summer wardrobe. Short sleeve Perma-Prest® dress shirts in solids, tone-on-tones and stripes. Popular colors.

Regular \$10 **5⁹⁹**

\$11 long sleeve shirts 6.59



**40% OFF
Tie Assortment**

Choose from stripes and patterns

Regular 6.99 **4¹⁹**

**Oxfords and Slip-ons
with features found
in our 24.99 shoe**

Durable sueded pigskin leather uppers, comfortable crepe sole and heel, leather trim. In tan or spice brown. Sizes 7½-11, 12D. 1500 pr. to sell.

Only **14⁹⁹** pr.

A special purchase, though not reduced, is an exceptional value.

The Shoe Place (not at Grosse Pointe)

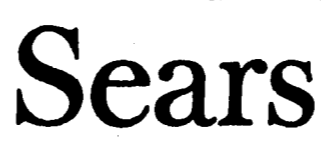
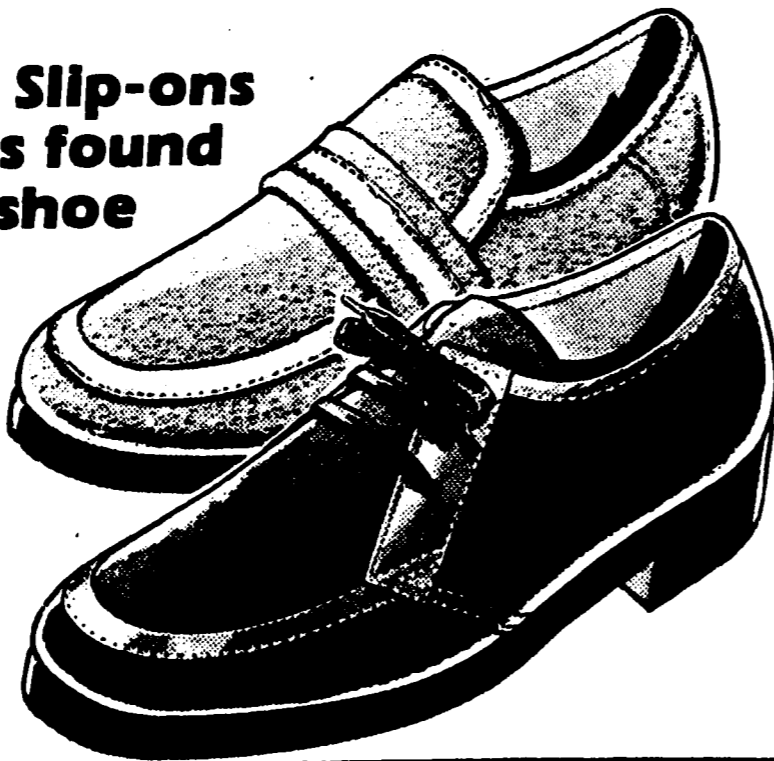

**Men's Cool
Casual
Summer
Slacks** **9⁹⁷** Regular Fit

Special purchase! Stylish straight legs in great summer colors. Each pair sports its own stretch belt. Lightweight polyester and cotton in choice of poplin or plain weave. Machine wash, tumble dry. 2,000 to sell.

Full fit sizes 11.97

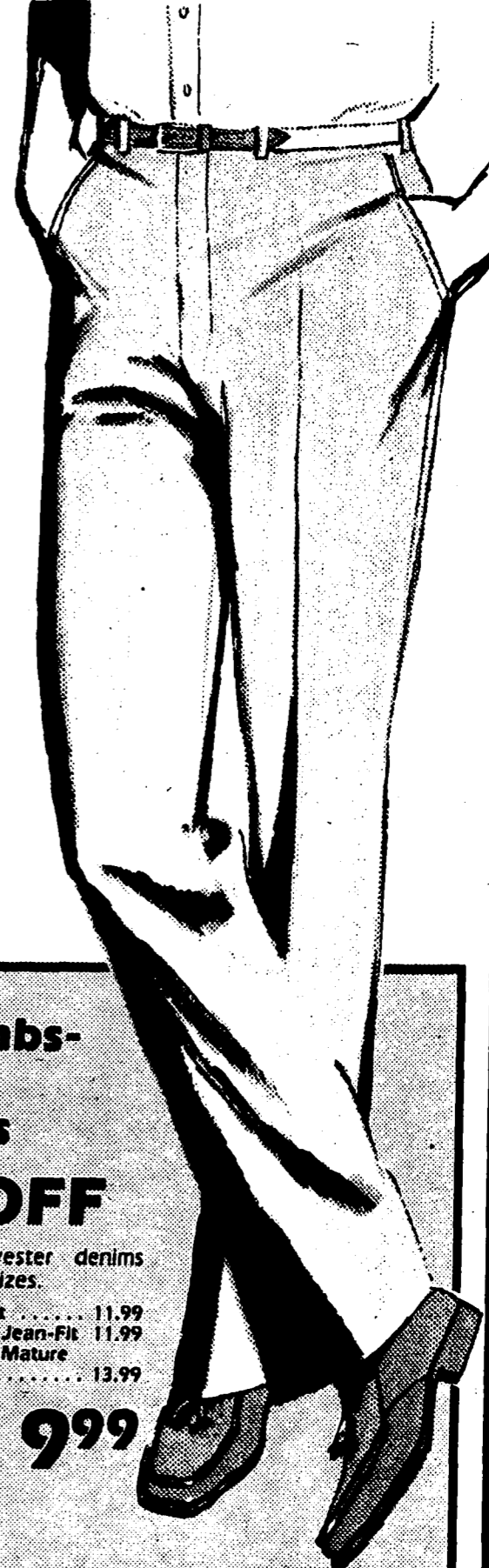

**Thumbs-Up®
Jeans**

\$3 OFF

Cotton/polyester denims in Jean-Fit sizes.

\$15 Mature fit 11.99
\$15 Washed, Jean-Fit 11.99
\$17 Washed, Mature Fit 13.99

Reg. \$13 **9⁹⁹**

**Special Purchase
Western Style Shirt**

Quality features include front and back yokes, extra long tails; snap front, cuffs and pocket flaps. Yarn-dyed polyester and cotton plaids in short and long sleeve styles.

2,000 to sell **6⁹⁷** each

Sale prices end June 19
The Men's Store (not at Grosse Pointe)

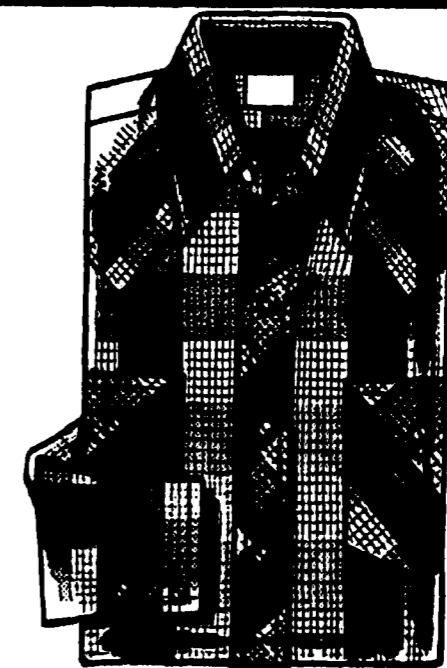

Use SEARSEARCH Credit Plan

SEARS ALL-STAR



FATHER'S DAY SALE

You can count on



Satisfaction Guaranteed
or Your Money Back

Open 9:30 am to 9 pm Monday through Saturday; Sundays 12 noon to 5 pm

- Macomb Mall 293-8000
- Portiac Mall 681-9900
- Twelve Oaks/Novi 348-9200
- Oakland Mall 585-1000
- Livonia Mall 476-6000
- Fairlane/Dearborn 336-0100
- Southfield 559-8000
- Lincoln Park 383-7000
- Briarwood/Ann Arbor 769-8900
- Lakeside/Sterling Heights 247-1500

Open 9:30 am to 6:30 pm (Mon. thru Fri.)
Sat. 9:30 to 6 — Closed Sunday
• Highland Park 668-1300

Open 9:30 am to 9 pm (Mon. thru Fri.)
Sat. 9:30 to 6 — Sun. 12 to 5
• Grosse Pointe Farms 684-6000

Sears



25% OFF
Dresses for an
Easy Transition

Mocha and beige: a year-round color story. Interpreted here in polyester one and two piece dresses and jacket dresses. For misses' sizes 8 to 18.

Regular \$27 **18⁹⁹**

Dress Department (not at Grosse Pointe)
Sale prices end June 19



\$3 OFF

Cool cotton tops and shorts

Sleeveless, Perma-Prest® tops of cool cotton knit in white, red, blue, yellow, green, lilac. Misses' S, M, L.

Reg. \$10 **6⁹⁹** ea.

Pull-on cotton Perma-Prest® shorts freshened with white piping. Red, navy, yellow, blue, green. Misses' S, M, L.

Reg. \$8 **4⁹⁹** pr.

In our Sportswear Department
(not at Grosse Pointe)



LAST 4 DAYS
Semi-Annual Sale
of Intimate Apparel

- A. Double-doubleknit bra. Natural or contour cups. Reg. \$8.50 ea. **5.89**
- B. Combed cotton briefs. Reg. \$5.50 pr. **3.85**
Extra sizes priced higher
- C. Endurables™ Thi-tops. Reg. \$2.79 pair **1.89**
- D. Floral Impressions nightwear. Nylon tricot. Long gown, reg. \$17 **11.49**
Long coat, reg. \$19 **12.99**
Short and woven styles also on sale
- E. Stretch 'N' Cross bra. Natural or contour. Reg. \$6.50 **4.49**
- F. Endurables pantyhose. Our longest wearing hosiery. Reg. \$3.19 pr. **2.09**

D cup bras on sale at higher prices

Lingerie (not at Grosse Pointe)

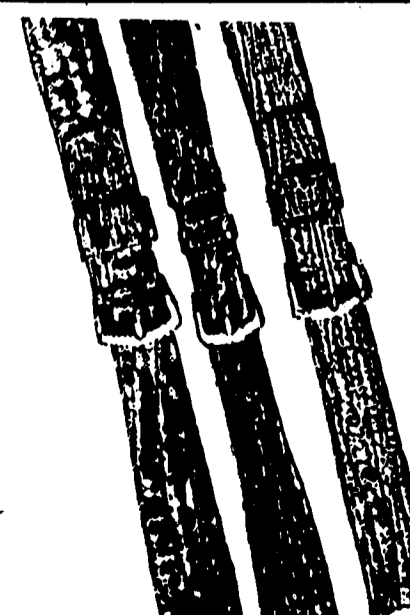

SAVE 40%
Ladies & gents
leather straps

Select an elegant leather watch strap to replace your old or worn-out band.

Reg. \$6.95 and up **4.17**

and up
Watch Repair Dept.
(not at Grosse Pointe, Southfield)

Watch repair, engraving, ring sizing, jewelry redesigning and most types of electric and digital watch batteries.

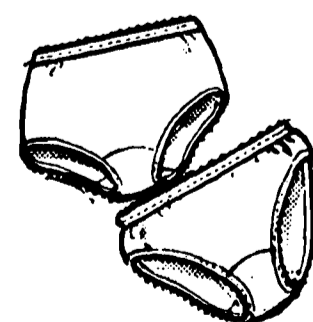

Bikini, hip-hugger
Reg. \$5.50 pr. **3.85**

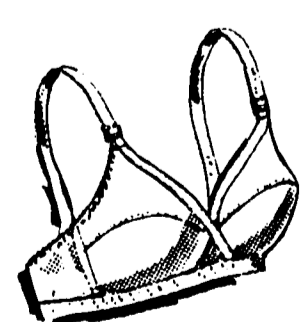

Cross-over bra
Reg. \$4.50 **3.09**



Full slip
Reg. \$9 **6.29**

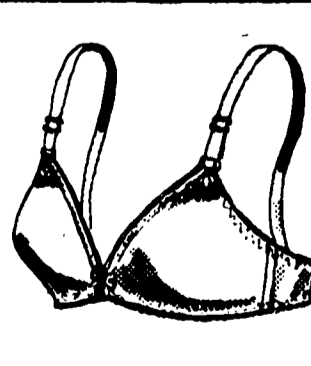

Teen bra
Reg. \$3.50 **2.39**

SAVE \$10 to \$30

Sears

Car seats and strollers

\$10-\$20 OFF

Bikes for the family



\$30 OFF
10-speed racer

Reg. \$149.99 **119⁹⁹**

26-in. racer for men or women. Shimano Positron™ derailleur lets you preshift while pedalling, coasting, stopped.

\$159.99 Men's 27-in. racer **129.99**

\$30 OFF 10-speed touring bicycle

Reg. \$159.99 **129⁹⁹**

26-in. for men or women. Shimano Positron™ derailleur. Rear carrier. Green color.

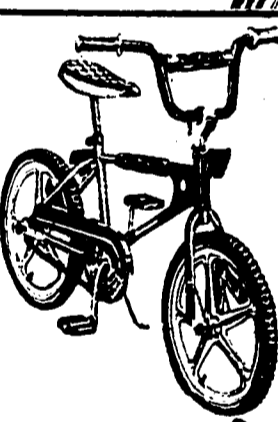

SAVE \$15 on boy's mag wheel BMX bike
Frame is reinforced for strength. Yellow plastic mag wheels, coaster brake, 3 BMX pads.

Reg. \$129.99 **114⁹⁹**

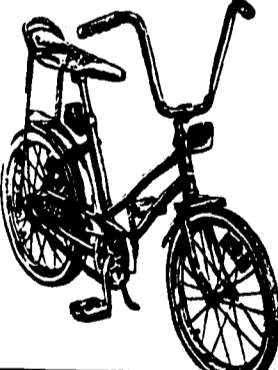

SAVE \$10 on girl's 20-in. hi-rise bike
Rear coaster brake. Decorated banana saddle and chain guard. White sidewall tires.

Reg. \$89.99 **79⁹⁹**

Sears bike accessories

Reg. 7.99 MX-lock tire 20x1.25 blue or red **5.99**

Reg. 6.99 Bicycle 48-in chain lock (not shown) **3.99**

Reg. 13.99 Bicycle air pump **10⁹⁹**

Reg. 9.99 Day-pack (not shown... \$9.99)
Sale prices end June 19
Sports Center (not at Grosse Pointe)

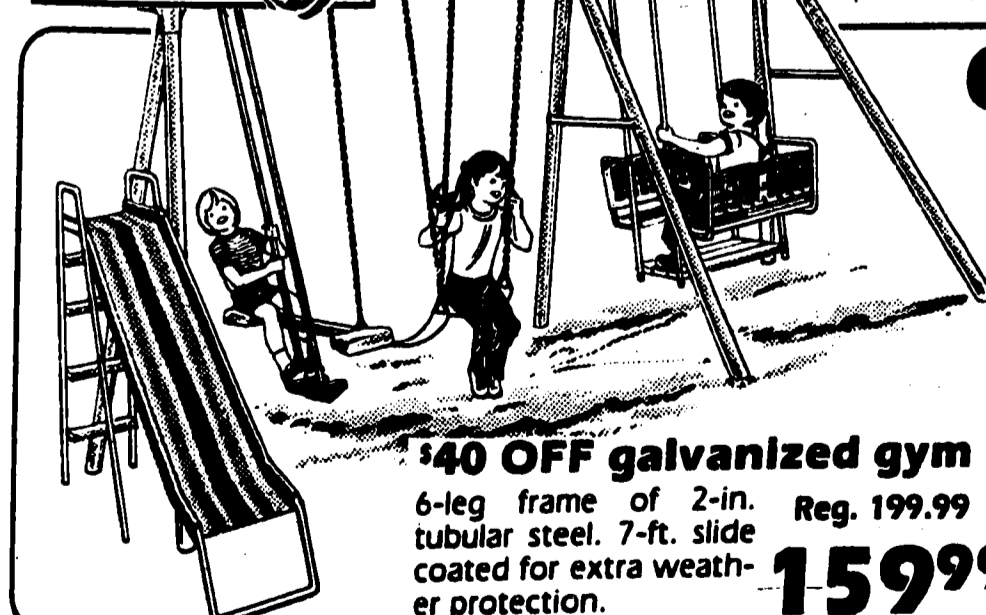

\$40 OFF galvanized gym

6-leg frame of 2-in. tubular steel. 7-ft. slide coated for extra weather protection.
Reg. 199.99 **159⁹⁹**

GYM SET SALE



\$30 OFF 6-leg swing set

6-leg frame, 5 1/2-ft. slide with rides. Reg. \$129.99 in 1982 Toy Catalog. **99⁹⁹**



\$20 OFF Big 'T' gym

Rugged 2-in. tubular steel frame, trapeze, swing rings, over-head bars, more. Reg. 109.99 **89⁹⁹**

Sale prices end June 19
Toy Dept. (not at Grosse Pointe)

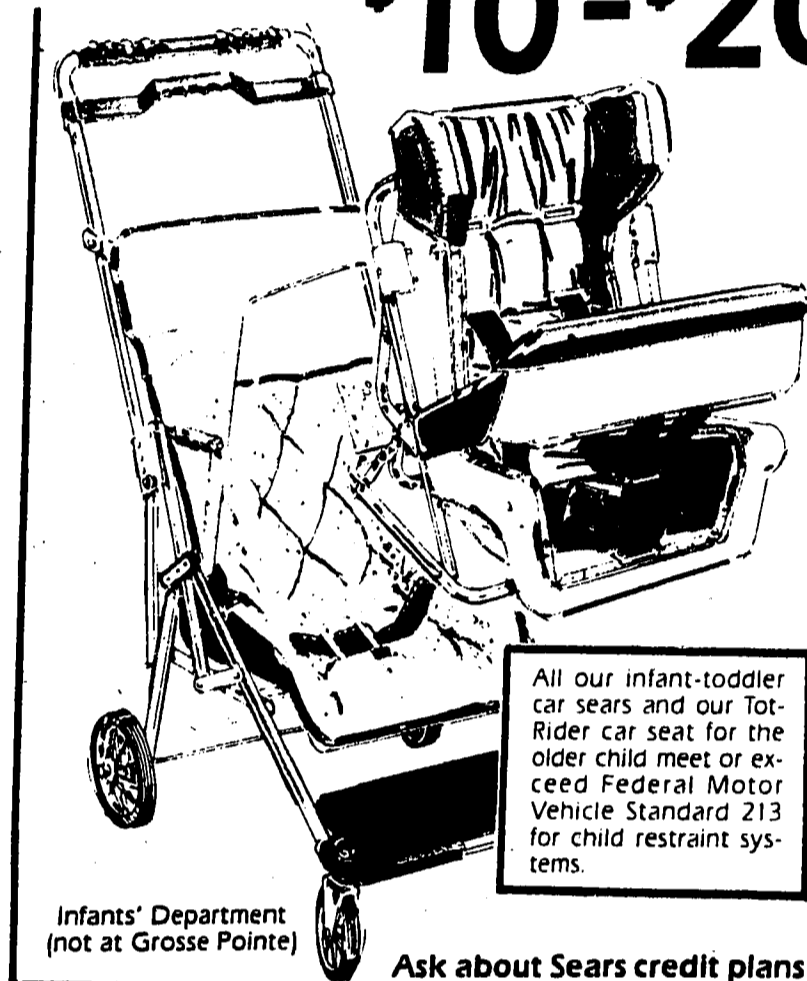

Wee Care car seat

Adjusts to rear facing for infants and front facing for toddlers. Chrome-plated steel frame, plastic shell.

Reg. \$59.99 **47⁹⁹**

Maxi-Taxi stroller

Open and close with one hand! Folds without removing canopy. Back reclines.

Reg. \$69.99 **49⁹⁹**

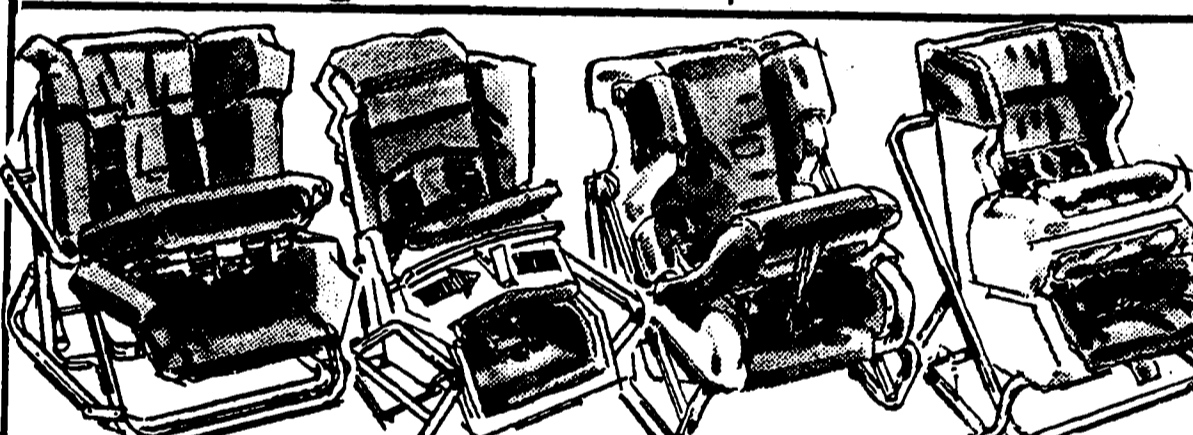

One Step™ padded car seat. Reg. \$54.99 **39⁹⁹**

Bobby Mac™ car seat. Brown. Reg. \$49.99 **39⁹⁹**

Century™ 300 car seat. Reg. \$59.99 **47⁹⁹**

High-Rider car seat. Corduroy seat. Reg. \$59.99 **47⁹⁹**

Toddler car seat. Plastic shell. Reg. \$29.99 **19⁹⁹**

Swivel wheel umbrella stroller. Reg. \$39.99 **29⁹⁹**

OK Baby swivel wheel stroller. Reg. \$44.99 **32⁹⁹**

Patchwork stroller. With parcel basket. Reg. \$39.99 **29⁹⁹**

Ask about Sears credit plans

Most Sears Stores Open 9:30 to 9 MONDAY through SATURDAY — SUNDAYS 12 to 5 (Highland Park 9:30 to 6:30 Mon-Fri.; 9:30 to 6 Sat.; closed Sun.) (Grosse Pte. 9:30 to 9 Mon-Fri.; 9:30 to 6 Sat.; 12 to 5 Sun.)

• Macomb Mall 213-8000 • Oakland Mall 585-1000 • Southfield 559-8000 • Pontiac Mall 481-9900 • Livonia Mall 476-6000 • Lincoln Park 383-7000 • Twelve Oaks 248-5200 • Farmington 336-0100 • Lakeside 247-1500 • Briarwood 769-8700 • Highland Park 866-1300 • Grosse Pointe 894-6000

You can count on **Sears**

Satisfaction Guaranteed or Your Money Back

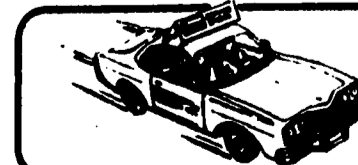

GIFT CERTIFICATES FOR ADULTS AND TEENS
Available at Sears Customer Convenience Centers

DRIVING SCHOOL

• Adult Free Home Pick-up • All-Weather Instruction
• Handicap-Hand Control • Dual Control Cars • Teen Classroom

Call **548-8000** or **548-8005**

Use Your Sears Charge

Sears

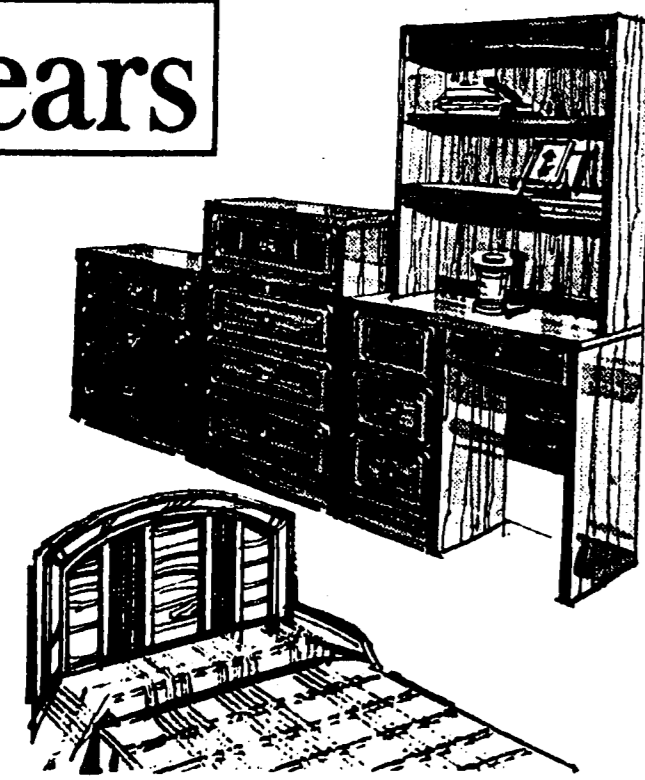

SAVE \$20
Contemporary modular bedroom pieces
• Chest • Student desk • Large hutch
13988
Reg. \$169.99

Selection 1. Simulated cane trim and brass-plated hardware accent these pieces.
\$89.99 Mirror \$60
\$149.99 Bachelor chest \$129.88
\$109.99 Twin size headboard \$79.88
Other matching pieces also on sale
Sale ends June 19



SAVE \$70
on twin size canopy bed
with rails and frame

Regular \$169.99 **9988**
Bonnet has the authentic look of French Provincial styling everyone will love! Delicate gold color detailing, an antique white finish and plastic laminated tops.
\$189.99 Full canopy bed 119.88

SAVE \$20-\$40
on matching pieces
Your choice
Reg. \$159.99-\$179.99 **13988**

• Single dresser • Poudre table
• Corner unit • Large hutch
• Student desk • Chest
\$99.99 mirror or chair 89.88 ea.
\$109.99 mirror 99.88

Sale ends June 19
Furniture Dept. (not at Grosse Pointe)

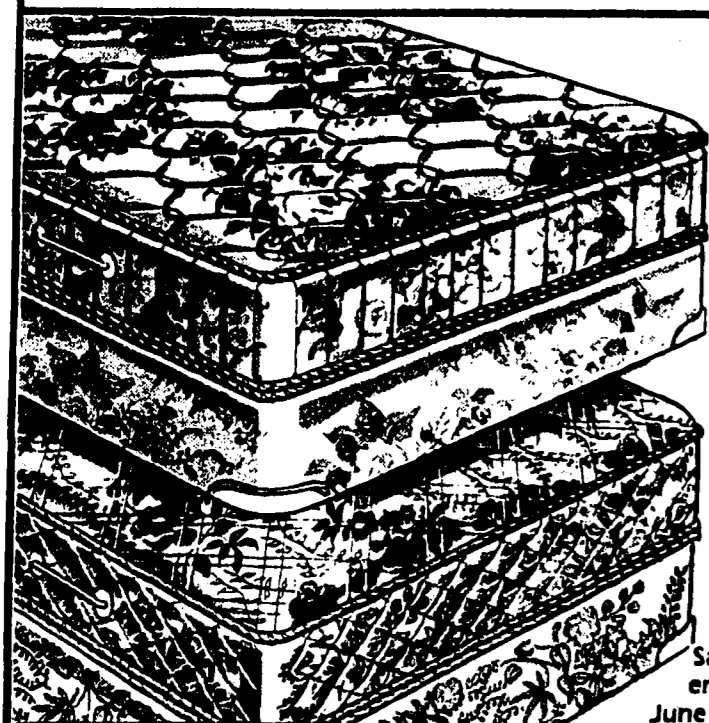

SAVE \$80-\$160
on Sears bedding sets
Available by the piece for only...

Reg. \$129.99 **8988**
Twin innerspring, polyurethane foam mattress or box spring
Cozy Nights bedding
\$169.99 Full mattress or box spring \$129.88
\$419.99 Queen size set \$319.88
\$499.99 King size set \$419.88

Seromatic bed frame
Reg. \$49.99
3988
Twin/full
Sale ends June 19

Reg. \$189.99 **12988**
Twin innerspring, Serofoam polymeric mattress or box spring
Sears-O-Pedic® Supreme
\$229.99 Full mattress, or box spring \$179.88
\$394.99 Twin longster set \$289.99
\$559.99 Queen size set \$429.88
\$699.99 King size set \$539.88

Brass headboard
Reg. \$249.99
21988
Twin size



SAVE 25% to 50%
on ALL custom woven woods and over 500 selected custom fabrics

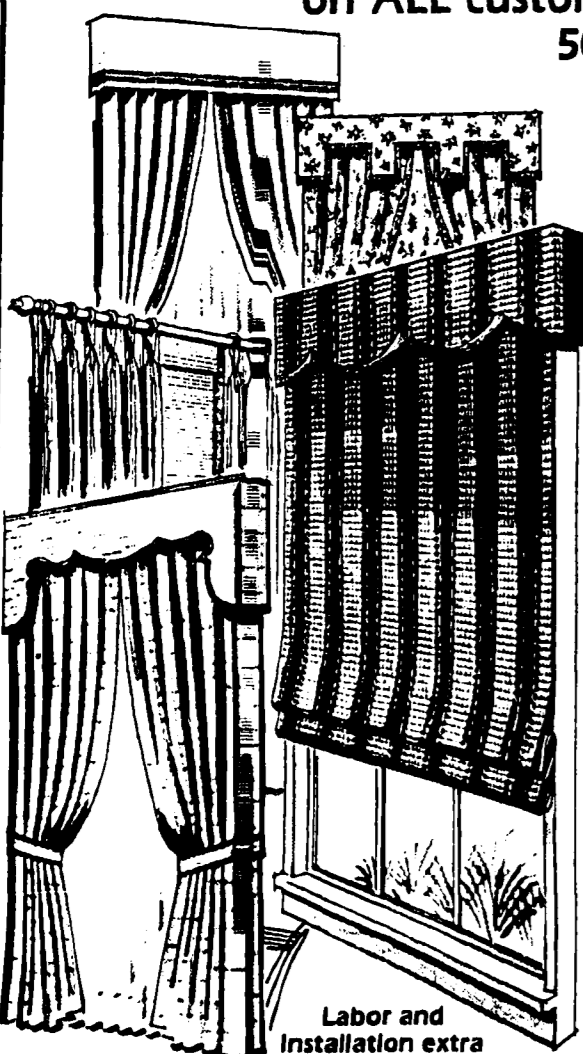

Let a Sears decorator show you our collection of decorative woven woods in roll-up or Roman shade styles. We'll bring samples to your home so you can actually see the wide selection of rich colors and patterns available. PLUS, you also save now on over 500 selected custom fabrics, including open or closely woven styles, lining, and many more!
Sale ends June 19

Phone toll-free 800-462-0866 for Sears shop-at-home custom services
Labor and installation extra

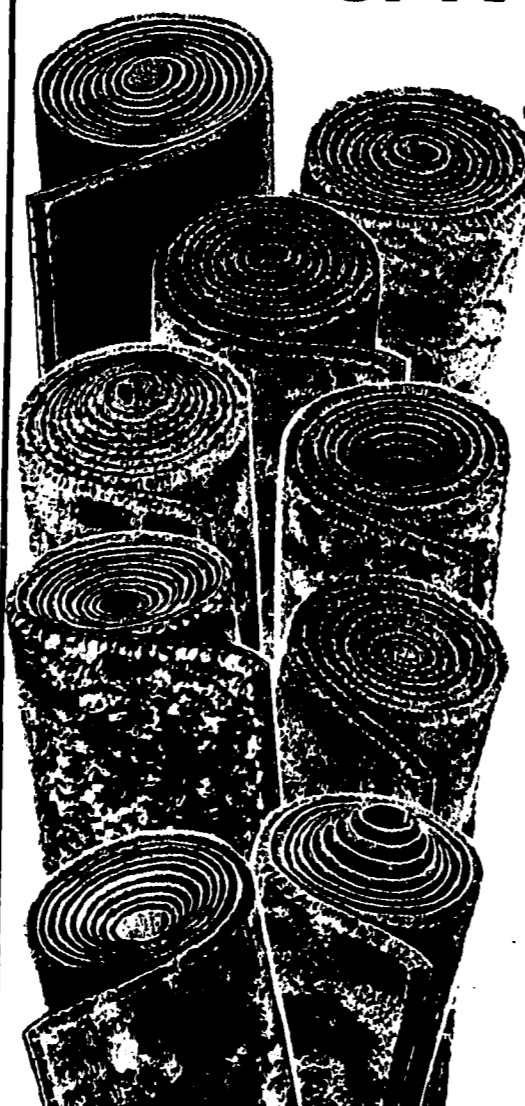

SAVE \$1 to \$7 a sq. yd. on selected carpets

Duradense Reg. \$7.99 **599** sq. yd.
Our **Stysetter** Collection carpets are made of nylon pile.
\$15.99 Grand Splendor 11.99 sq. yd.
\$19.99 Grand Design 14.99 sq. yd.
\$22.99 Rare Visions 16.99 sq. yd.
\$26.99 Noble Visions 19.99 sq. yd.
Amber Glow Reg. \$7.99 **699** sq. yd.
Our **Glow** Collection carpets are made of sculptured nylon pile.
\$9.99 Summer Glow 7.99 sq. yd.
\$12.99 Nordic Glow 9.99 sq. yd.
\$15.99 Misty Glow 11.99 sq. yd.
\$19.99 Autumn Glow 14.99 sq. yd.
\$22.99 Majestic Glow 16.99 sq. yd.

Our **Shadows** Collection carpets are made of nylon plush pile. Regular \$9.99-\$26.99 ... 7.99-19.99 sq. yd.
Installation available
Sale ends June 26
Floorcovering Dept. (not at Grosse Pointe)

\$60 OFF
Touch n' Tune color TV

Sears

\$70 OFF
this Kenmore laundry pair



Reg. \$459.95 **39995** 42101
Enjoy a big, 19-in. diag. meas. picture! All electronic tuner is accurate, dependable. Touch 'n Tune channel selection. Super Chromix® picture tube for vivid color.

\$10 OFF Reg. \$299.5 each
• AM/FM electronic LED clock radio. Wake to radio or alarm. Slide-rule tuning, digital LED display. Battery back-up; batteries extra
• Portable AM/FM stereo radio with ultra light headphones. *batteries extra

\$100 OFF Video recorder
BetaVision 11/11. Up to 5-hours per tape. Reg. \$699.95 **599.95**

\$100 OFF Videodisc player
2-speed visual search. Digital indicator. Reg. \$399.95. **299.95**

\$30 OFF Black/white TV
12-in. diag. meas. picture. AC/DC. Reg. \$119.95. **89.95**
batteries extra

\$30 OFF portable stereo
Cassette play/record. AM/FM stereo radio. Reg. \$169.95 **139.95**
AC/DC; batteries extra

\$30 OFF Carpet cleaner
Sprays hot solution deep into carpet. Loosens and removes deep down dirt. Reg. \$159.95 **129.95**

10-stitch sew head
5 built-in utility, stretch stitches. Built-in bar tack button-holer. Free-arm. Special Purchase. Reg. \$169.95 **1249**

\$40 OFF Canister vacuum
Powerful suction combined with a beater bar brush for deep, embedded dirt. Edge cleaning. Reg. \$209.95 **169.95**
A special purchase, though not reduced, is an exceptional value

\$20 OFF hand vac
With attachments. Powerful motor, twin fans. Ideal for car, motor homes, etc. Reg. \$64.95 **49.95**
Sale ends June 19

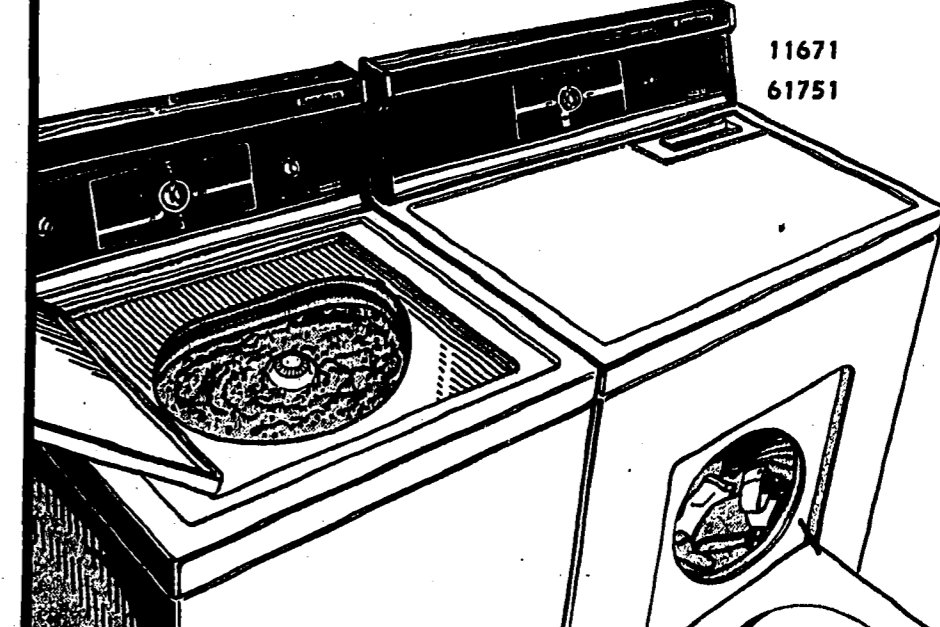

11671 61751
2-speed washer
Heavy-duty 5-cycle washer with 3 water temperature combinations, 3 water levels, self-cleaning filter.
Reg. \$379.95 **349.95**
White, colors extra

Electric dryer
Automatic termination... heat shuts off at the preset dryness you select.
Reg. \$299.95 **259.95**
\$339.95 Gas Model 299.95
Sale ends July 3

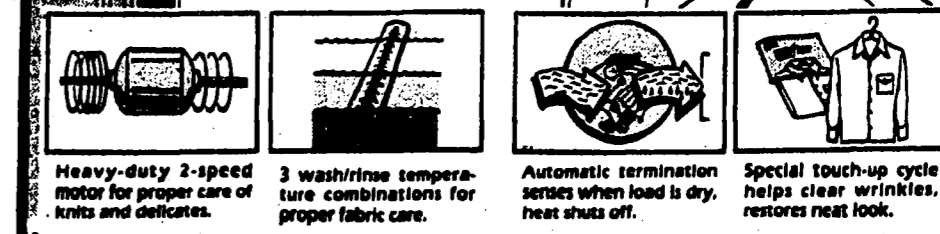

Kenmore washer
Heavy-duty model with 3 water temperature combinations. Pump protector. White only. **\$279**

Electric dryer
Heavy-duty model. 2 cycle with air only for fluff-drying. Lint Filter. White only
\$219
Kenmore Gas Model \$259

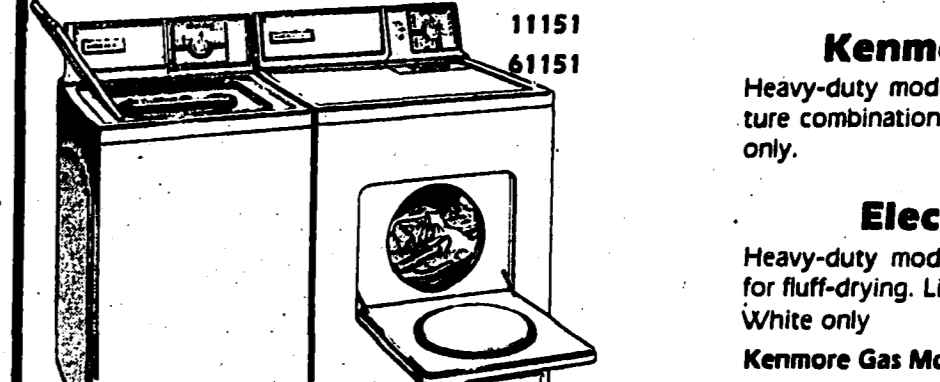

\$80 OFF refrigerator
Frost-free 15.1 cu. ft. with 10.84 cu. ft. refrigerator, 4.25 cu. ft. freezer. Porcelain-on-steel interior. White.
Reg. \$579.95 **499.95**
Sale ends June 26

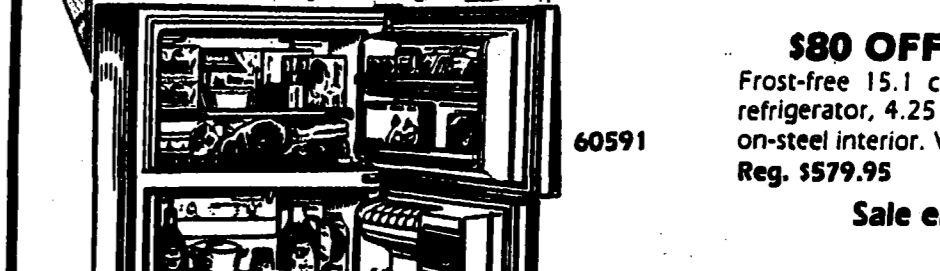

\$120 OFF side-by-side
22.2 cu. ft. with 14.73 cu. ft. refrigerator, 7.50 cu. ft. freezer. All frostless. White.
Reg. \$999.95 **879.95**
Sale ends July 3



\$60 OFF freezer
18.1 cu. ft. chest type. DynaWhite epoxy-finish interior. White.
Reg. \$459.95 **399.95**
Sale ends July 3



SAVE \$120 on microwave with memory
2-stage memory, programmed defrost by time, delay start, whole-meal cooking. Oven light.
Reg. \$199 **\$179**
\$529.95 **399.95**
Sale ends June 26
Sale ends June 19



\$20 OFF Compact microwave
0.5 cu. ft. oven. 10-min. timer. Oven light.
Reg. \$199 **\$179**
\$529.95 **399.95**
Sale ends June 26
Sale ends June 19

\$100 OFF gas grill
460 sq. in. cooking area includes warming rack. Match-free ignition light instantly. Dual controls. Reg. \$299.95. **199.95**
Sale ends July 3
Appliances also available at Sears Brighton and Howell stores.

Each of these advertised items is readily available for sale as advertised

Sears

Sale prices end June 19 except where noted

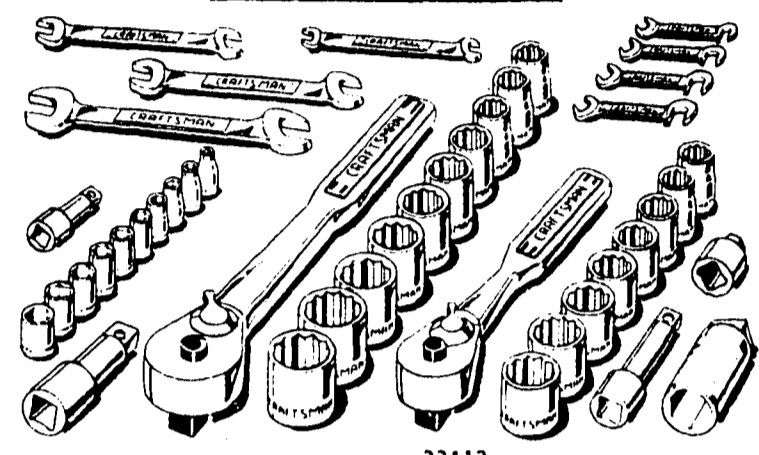

SAVE \$97 Craftsman 43-piece tool set

Includes two reversible quick-release ratchets, 1/4, 1/2 and 3/4-in. drive sockets, adapter, extension bars and wrenches.

Reg. sep. prices total \$147.01
4999

Sale ends June 19

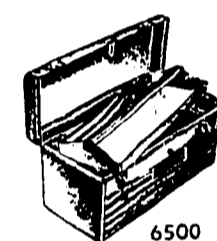

\$4 OFF Tool box
Steel with handy tote tray.
Reg. \$21.99
1799

Use your SEARSEARCH



SAVE \$97 Workbench

Craftsman sturdy steel-frame outfit.
Reg. sep. prices total \$197.94
9999

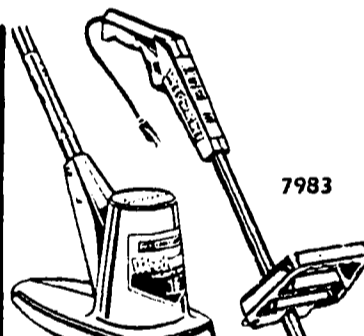

SAVE \$15 Electric trimmer

Weedwacker®. Semi-automatic line feed.
Reg. \$59.99
4499

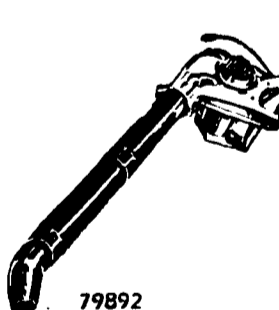

SAVE \$20 Power blower

125 MPH velocity developed at nozzle.
Reg. \$69.99
4999

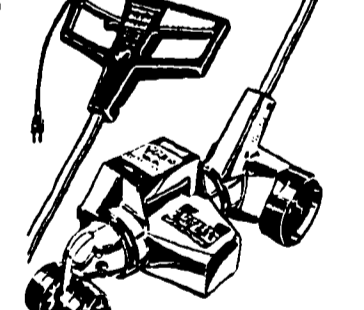

SAVE \$25 Edger-trimmer

Craftsman 1-HP heavy-duty electric model.
Reg. \$94.99
6999



SAVE \$20 Hedge trimmer

18" electric with 3000 strokes per minute.
Reg. \$59.99
3999

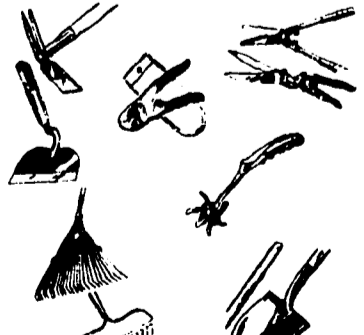

SAVE \$3-\$5 Garden tools

Shovel, rakes, hoes, shears, cultivator, more.
Reg. \$8.99-\$10.99
599 each

SAVE \$160 or \$200 on these Craftsman 10-in. saws

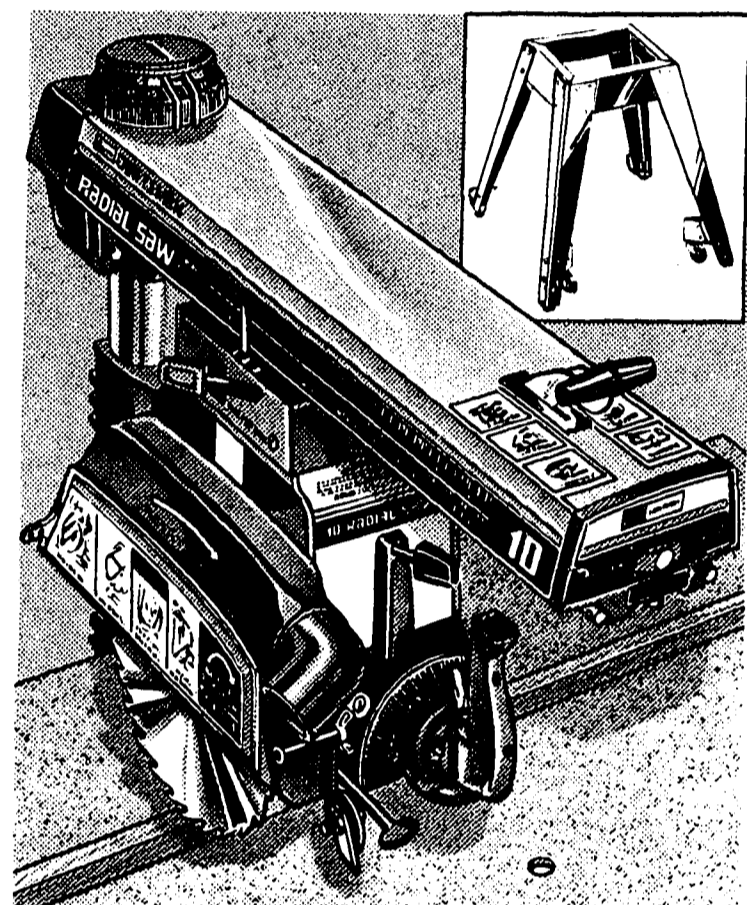

Radial saw, Reg. sep. prices total \$539.97

33999

With steel legs set and casters. Capacitor-start, induction-run 1 1/2-HP motor develops 2 1/2-HP. Up-front controls.

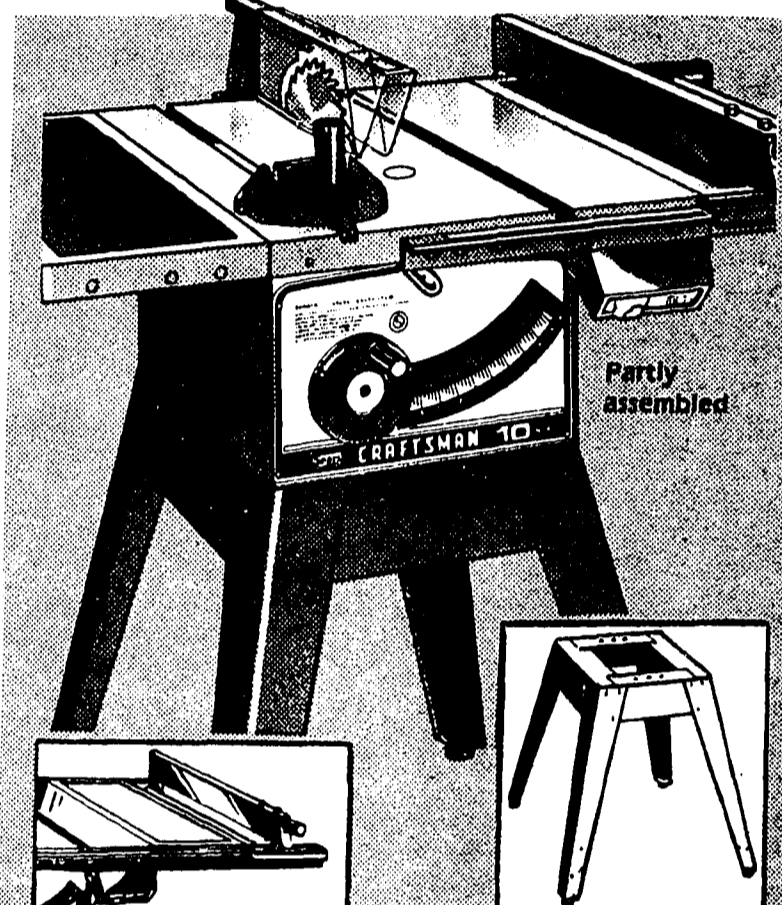

Table saw, Reg. sep. prices total \$459.99

29999

Capacitor-start 1-HP motor develops 2-HP. Cast-iron top with Exact-1-Cut indicator. Leg set, 2 table extensions.

Sale ends July 3

Your choice \$10

- A. \$22.96*, 4-pc. auger bit set
- B. \$15.99, 25-ft. measuring tape
- C. \$22.99, 26-in. hand saw
- D. \$22.47*, 3-pc. universal joint set
- E. \$23.52*, 8-pc. screwdriver set
- F. \$20.25* standard size 5-pc. wrench set or 19.85* metric 5-pc. wrench set
- G. \$21.75*, extension bar set
- H. \$13.99, 10-in adjustable wrench
- J. \$13.98*, 2-pc. locking pliers set
- K. \$16.99 Screwball® screwdriver
- L. \$17.98* Sears 2-pc. pipe wrench set
- M. \$17.99 Impact driver

*Regular separate prices total

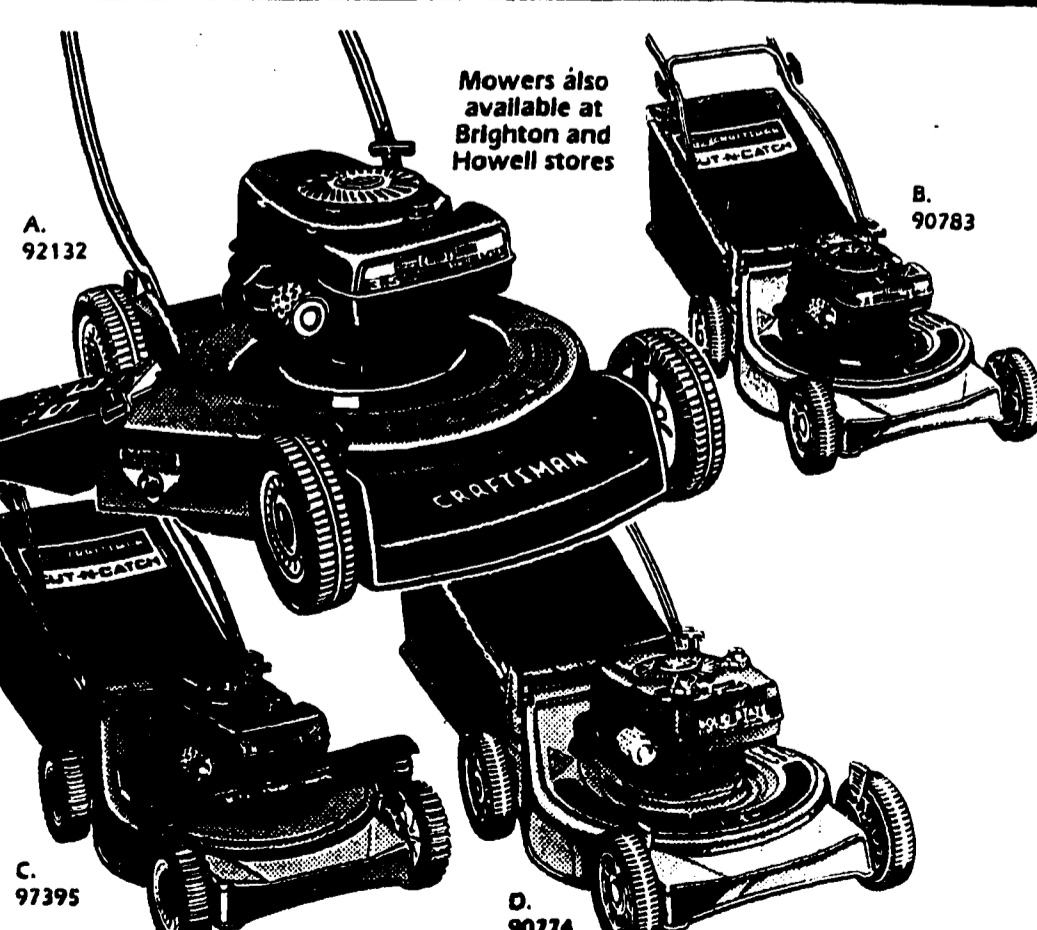

SAVE \$40 to \$60 These Craftsman Power Mowers

- A. **\$40 OFF 20" push mower**
3.5-HP gas engine. Solid state ignition. Reg. \$209.99
16999
- B. **\$50 OFF 20" rear-bagger**
3.5-HP engine. 5 position wheel adjusters. Reg. \$249.99
19999
- C. **\$50 OFF 20" rear-bagger**
3.5-HP engine. Single speed cog drive. Reg. \$299.99
24999
- D. **\$50 OFF 20" rear-bagger**
4.9-HP dual power engine. Push-type. Reg. \$279.99
22999

Sale ends June 26

SAVE 50% Sears Central air conditioning ONLY \$649

on Armadillo® chain link fencing fabric when you buy posts, top rail and fittings at reg. prices



Adds long-lasting privacy and security to your home. Triple-coated framework contains 50% more rust-resistant zinc than that of our leading competitor. 48, 60, and 72-in. heights are on sale.

Ask about Sears Authorized Installation for items on this page
FREE Estimates!

Sale ends June 19 (also available at Brighton and Howell)

SAVE \$20 1/3-HP garage door opener

Reg. \$189.99
16999

Choose from over 3,000 digital codes for security. Sectionalized rail makes installation easy.

Sale ends June 19 (also available at Brighton and Howell)

Ask for the INSTALLED Price

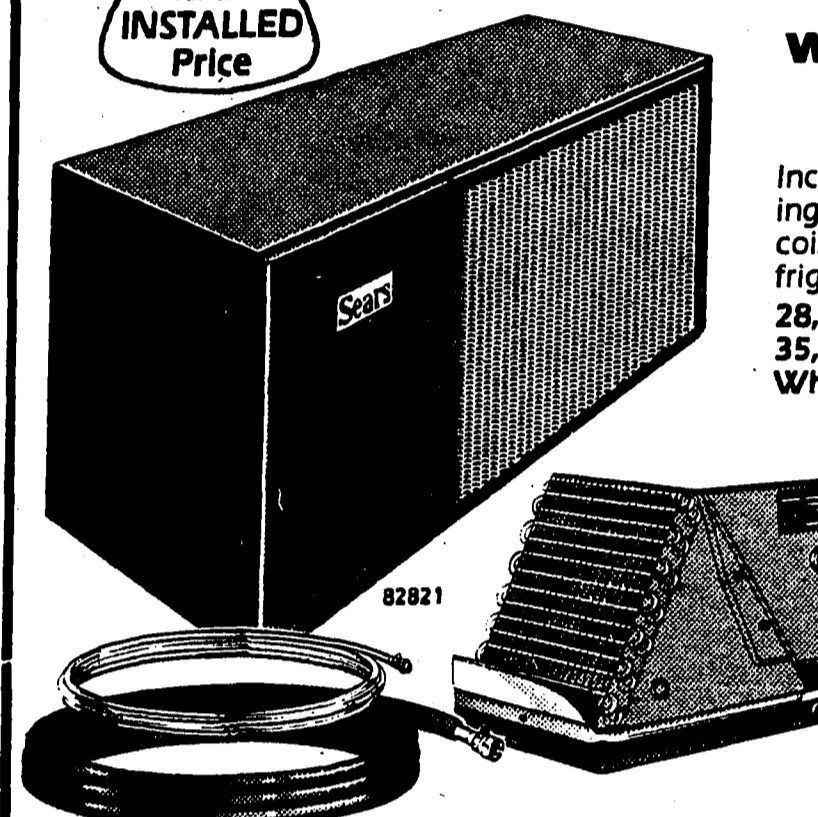

22,800 Btuh whole house system

Includes outdoor condensing unit, indoor evaporator coil and 25-ft. of copper refrigerant tubing.

28,400 Btuh system \$749
35,400 Btuh system \$799

While quantities last (also available at Brighton and Howell)

25% OFF Installation labor until July 3



SAVE \$40 on 24-in. whole house fan with louvered shutter

Fan is easy-to-install... no attic joists to cut or frames to build. White shutter (included) opens automatically.
Regular \$239.99
19999
Variable speed

Sale ends June 26

Enjoy summer fun with a Bugwacker

\$30 OFF Bugwacker® bugkiller

Reg. \$29.99
9999
40-watt bug killer lures insects up to 110-ft. Bait tray for daytime use. Screen grid helps protect birds, fingers.
#1431 15-watt bugkiller \$4.99
Sale price ends June 19

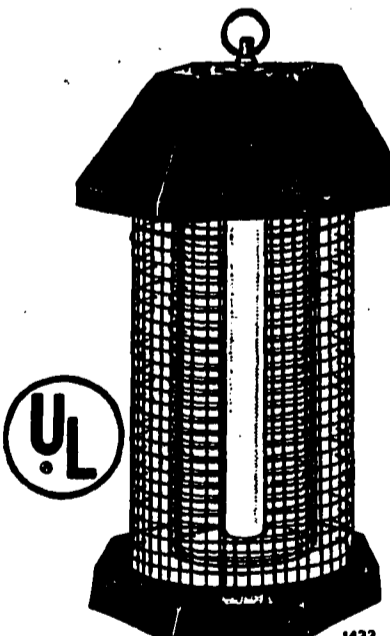

SAVE \$5 on 2-gal. sprayer

Reg. \$21.99
1699
Durable rust-resistant galvanized steel. Brass nozzle sprays fine mist to steady stream.
*\$29.99, 3-gal. sprayer, \$22.99
*not at Grosse Pointe, Southfield
Sale prices end June 26
Garden Shop (not at Southfield)

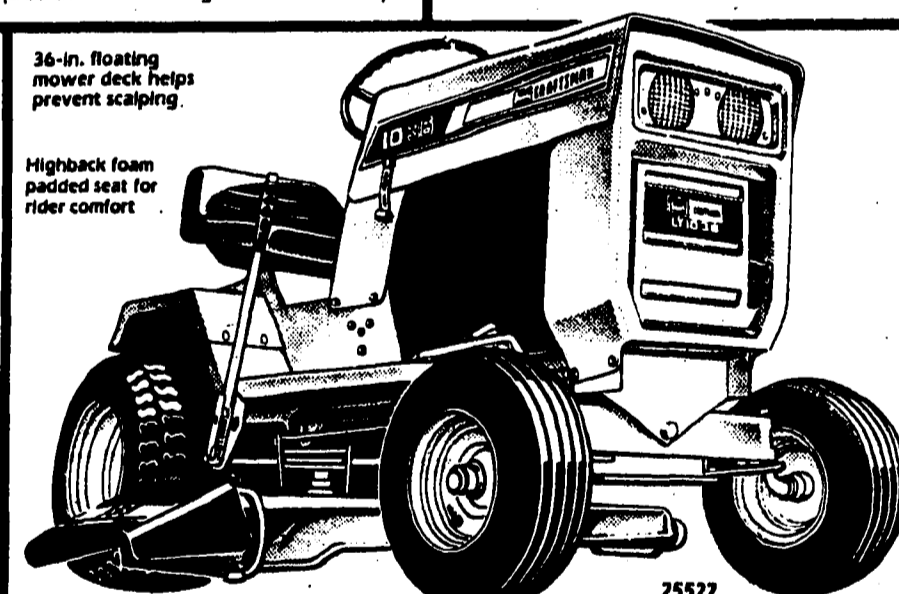

SAVE \$150 Craftsman 10-HP lawn tractor

Electric start. 3 speed trans-axle. 36-in. floating mower deck. Accepts optional attachments.
Reg. \$149.99
99999

\$100 OFF electric start 8-HP riding mower

30-in. single blade adjustable mower. Self-bagger extra.
Reg. \$999.99
89999

\$300 OFF 18-HP garden tractor

3-speed Vari-Drive. Manual master lift.
Reg. \$2199.99
189999
Sale ends June 19 (also available at Brighton and Howell)

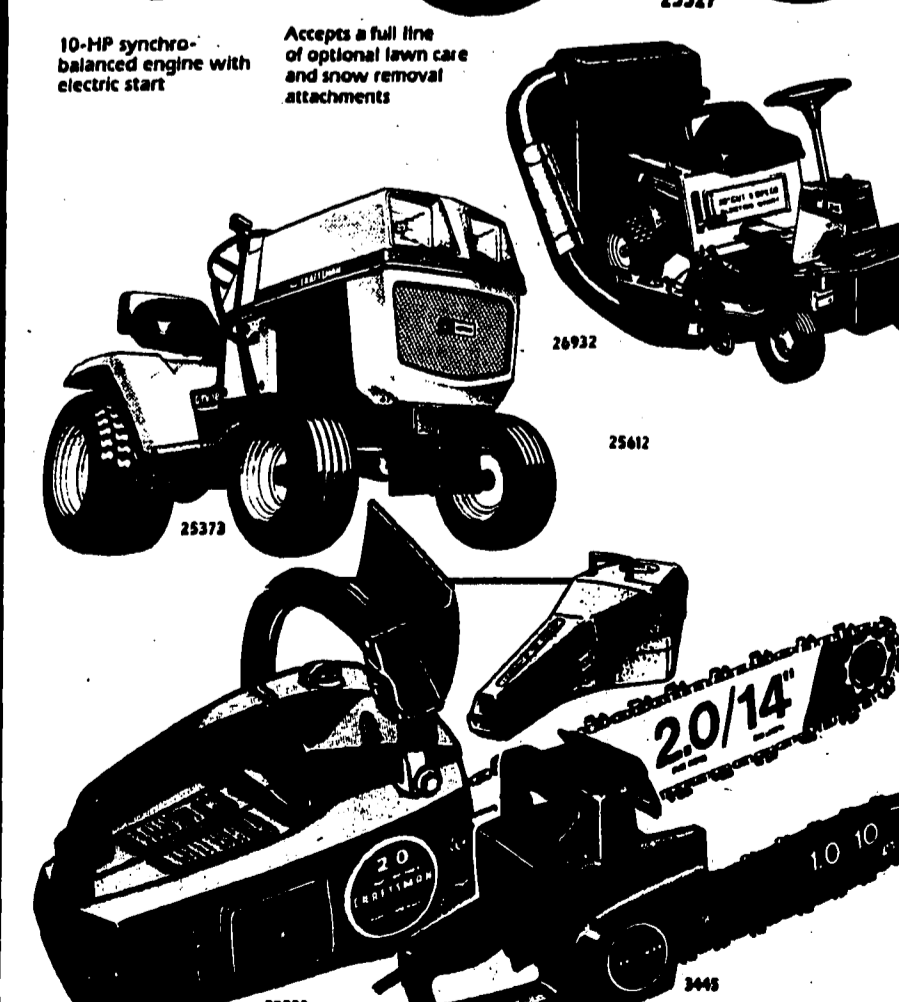

Attachments available at Sears
Spreader-blower, Blowing cart, Lawn mower

\$3299 OFF gas saw and case
Lightweight, powerful 2.0 cu. in. gas engine. 14-in. Lo-Kick guide bar. Reg. sep. prices total 202.98
16999

\$10 OFF electric saw
1-HP. 10-in. Lo-Kick guide bar. Double insulated. UL listed.
Reg. \$64.99
5499
Sale ends June 26

Sears

Paint also available at Brighton and Howell stores

SAVE
on these one-coat latex paints

For one-coat results, all Sears one-coat paints must be applied as directed



Easy Living® interior
Matt finish, Reg. \$15.99
10.99 gallon
Sears Best interior latex gives you washable one-coat coverage in 23 colors.
\$11.99 Latex Wall Paint. Flat or ceiling white.
14 washable colors 7.99 gallon
\$12.99 semi-gloss 8.99 gallon
Sale ends June 19

Weatherbeater® exterior
Flat, Reg. \$16.99
9.99 gallon
Sears Best exterior latex is stain and mildew-resistant. One-coat coverage in 50 non-yellowing colors. No chalk washdown.
\$18.99 exterior satin 11.99 gallon
Sale ends July 3

\$60 OFF
sprayer with case
Sears Best airless sprayer with case.
Reg. sep. prices total \$159.98
99.98
While quantities last

SAVE \$48 to \$96
on sets of 4
all-season radials



WeatherWise. Runs quietly yet gives great grip on wet, dry, snow and ice. Two long-wearing steel belts. Save now!

Sale prices end July 3

SAVE 25%
on fiber glass belted tires
SuperGuard 25. Two fiber glass belts for strength and long wear.

Bias-ply A78-13 blackwall **25.99** plus \$1.42 Federal Excise Tax
Guardman. Our lowest-priced polyester tire. Strong and smooth-riding.

SAVE \$5
on Heavy-duty RT shocks

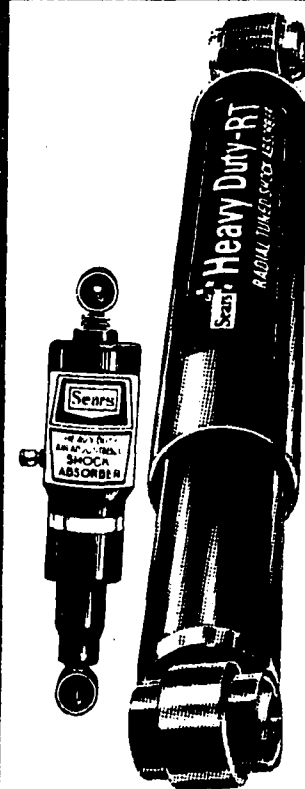

Regular \$14.99 **9.99** each
Radial-tuned comfort valve helps smooth ride with most tires. For most American-made cars, many imports.

\$10 off Air-adjustable shock absorbers
Regular \$69.99 **59.99** pair
Fully-adjustable load-lifting capacity—up to 1000 lbs.
Shock Installation extra
Sale prices end June 19

Indash AM/FM-stereo cassette with Dolby
Dolby® noise-reduction system. 14 amps of power per channel. Auto-reverse and locking fast forward on cassette. Installation extra
Was 199.99
139.99
Sale ends JUNE 19 OR WHILE THEY LAST



SAVE \$7 on Sears 36 car battery
325 amps cold cranking power. Group 24. For most American-made cars, many imports. Installed.
Reg. 44.99 with trade-in
37.99 with trade-in
Battery sale ends June 26

Spectrum 10W-40
Reg. 5.95 motor oil in 5-qt. container
4.95
Timing light
Reg. 44.99 Craftsman type
34.99
Auto analyzer
Reg. 59.99 per-forms 17 auto tests
Reg. 24.99 car vacuum 17.99
Reg. 2.99 auto compass 2.99
These sale prices end June 19

Sears Tire and Auto Center SPECIALS

Wheel bearing repack
Reg. 28.98 **18.88**
Clean inner and outer bearings, inspect and adjust to specs. Repack and install new grease seals.

FREE front end inspection
with 25% OFF front end parts installed
Sale prices end June 19

You can count on **Sears**
MARK ROEBUCK AND CO.

Satisfaction Guaranteed or Your Money Back

Open 9:30 am to 9 pm Monday through Saturday; Sundays 12 noon to 5 pm
• Macomb Mall 293-8000 • Portcullis Mall 681-9900 • Twelve Oaks/Novi 348-9200
• Oakland Mall 585-1000 • Livonia Mall 476-8000 • Fairlane/Dearborn 336-0100
• Southfield 559-8000 • Lincoln Park 383-7000 • Briarwood/Ann Arbor 769-8900
• Southfield 559-8000 • Lakeside/Sterling Heights 247-1500
Open 9:30 am to 6:30 pm (Mon. thru Fri.) Sat. 9:30 to 6 — Closed Sunday
• Highland Park 868-1300
Open 9:30 am to 9 pm (Mon. thru Fri.) Sat. 9:30 to 6 — Sun. 12 to 5
• Crose Pointe Farms 884-6000

SUPPLEMENT TO S.E.M. NEWSPAPERS INC., OBSERVER ECCENTRIC NEWSPAPERS, SLIGER NEWSPAPERS, DAILY TRIBUNE, YPSILANTI PRESS AND ASSOCIATED NEWSPAPERS.

CHATHAM

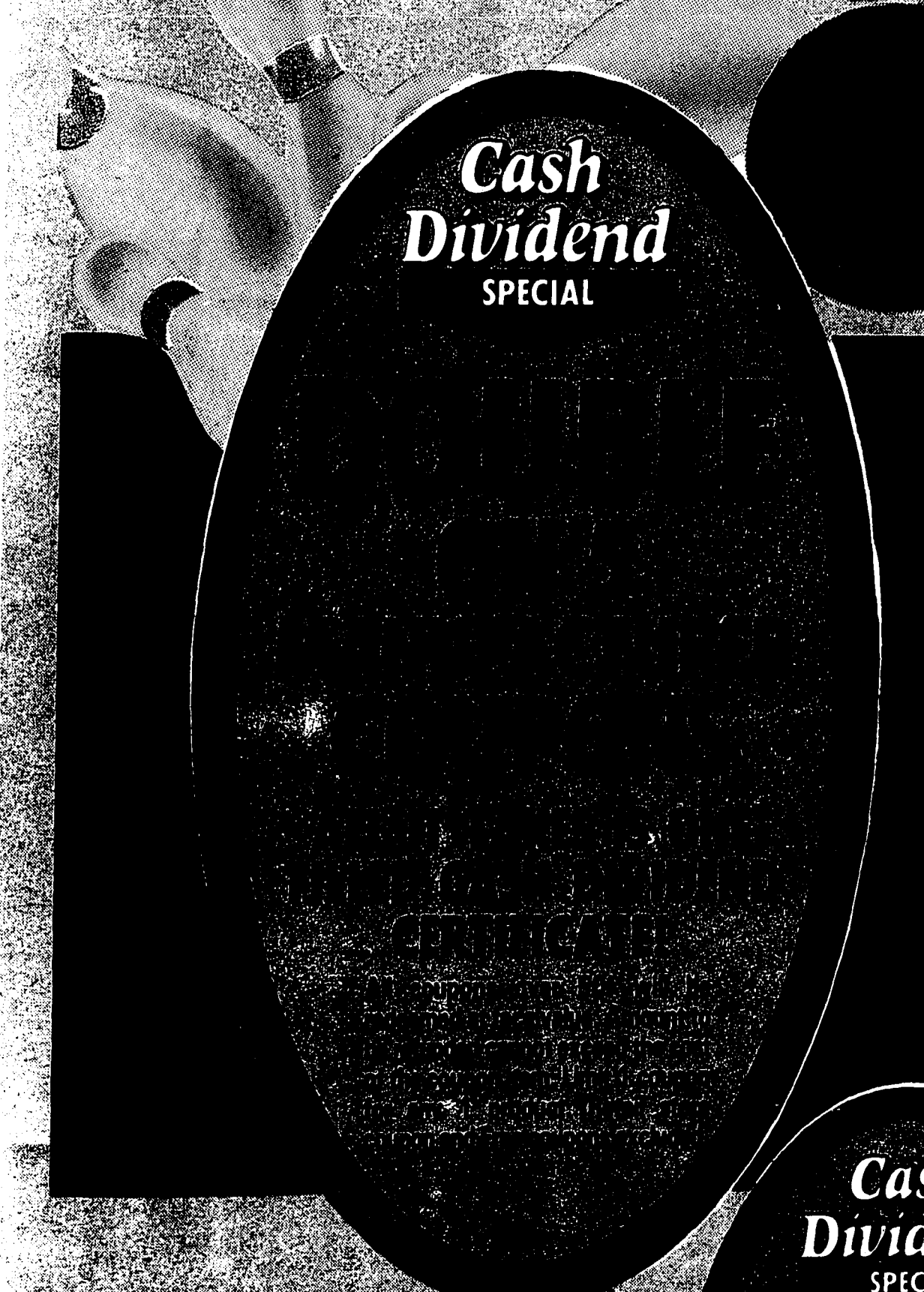

BOWL A FREE GAME
HERE'S HOW IT WORKS....

Just purchase from any Chatham Supermarket an 8-Pack of 1/2 liter bottles of Coke, Tab, Sprite, Dr Pepper, SunKist Orange or Squirt at the regular price of \$2.38 plus deposit, or as a Cash Dividend special at \$1.49 plus deposit, and Chatham will give you one certificate to bowl a free game at any one of 110 participating BPA Bowling Centers. You will receive one free bowling certificate for each 8-pack you purchase. A list of Participating BPA Bowling Centers is posted on every certificate. Offer expires June 22, 1982.

Chatham and the Michigan Bowling Proprietors Association have again joined to provide you with the opportunity to enjoy a free game of bowling fun. Bring the whole family and enjoy summer bowling together. Bowling is an inexpensive way to enjoy healthy entertainment.

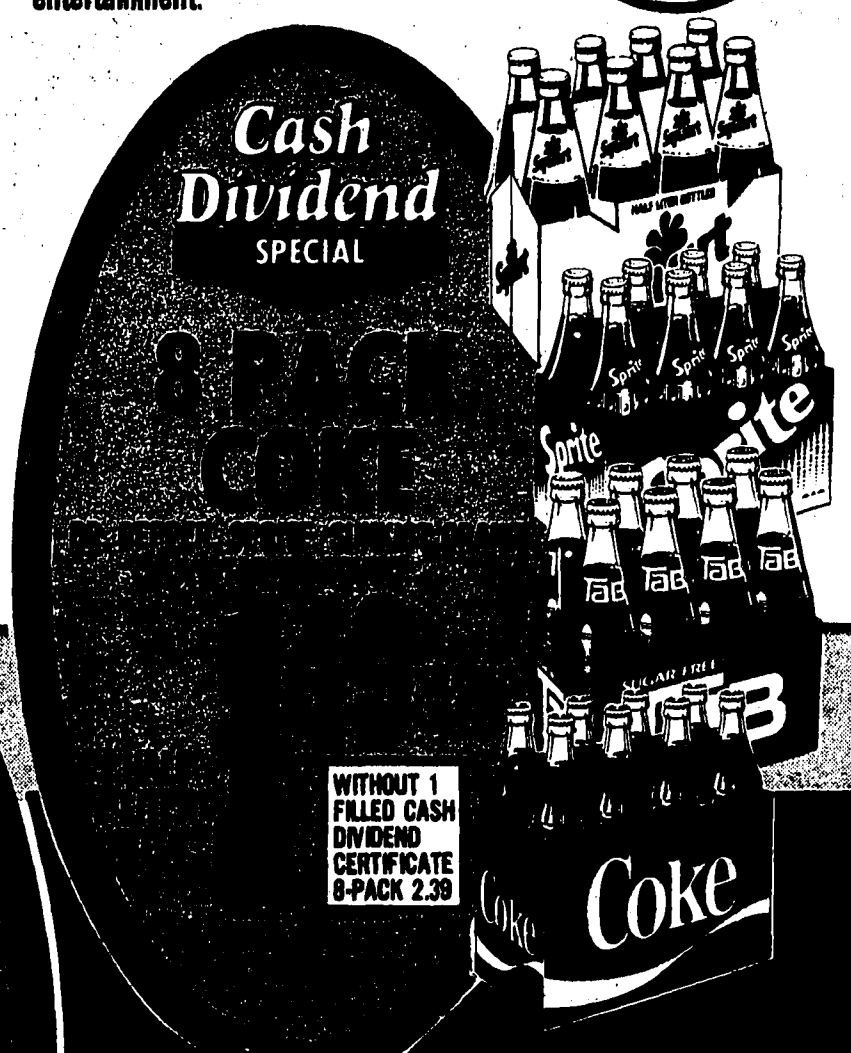

MOST STORES OPEN:
MONDAY THRU FRIDAY
8 A.M. TO 11 P.M.
SATURDAY 8 A.M. TO 10 P.M.
SUNDAY 9 A.M. TO 6 P.M.

KRAFT SPIRAL ELBOWS MACARONI & CHEESE
4 \$1
5 1/2-OZ. PKGS.

FRESH GRADE A COUNTRY PRIDE WHOLE FRYERS
58¢ **SAVE 21¢**
LB. **LIMIT 3 PLEASE**

PRICES EFFECTIVE AT ALL CHATHAM STORES JUNE 16 THRU 6 P.M. JUNE 22, 1982. WE GLADLY REDEEM U.S.A. FOOD STAMPS.

CHATHAM FOR MORE BUYING POWER



SUNSHINE KRISPY CRACKERS
REGULAR OR UNSALTED
1-LB. BOX **59c**



PRINCE SPAGHETTI SAUCE
PLAIN • MEAT • MUSHROOM
QT. JAR **89c**



KRAFT SPIRAL ELBOW MACARONI & CHEESE
NEW
5 1/2-OZ. PKGS. **\$1.49**

PLAIN OR PEANUT M & M CANDY
20% OFF LABEL
1-LB. **1.99**

GENERIC ELBOW MACARONI or SPAGHETTI
2 LB. PKG. **59c**

25% OFF LABEL AJAX DETERGENT
3-LB. 1-OZ. BOX **1.79**

CAMPFIRE MARSH MALLOWS
1-LB. **77c**

ALL FLAVORS CAPRI SUN FRUIT DRINKS
10 PK. **2.29**

DECAFFEINATED HILLS BROS COFFEE
1-LB. 10-OZ. JAR **6.49**

SUNSHINE BONUS PACK VIENNA FINGERS
1-LB. 1-OZ. **99c**

ASSORTED ROYAL PUDDINGS
4 1/2-OZ. **57c**

KRAFT MAYONNAISE
QT. **1.59**

ALL GRINDS MAXWELL HOUSE COFFEE
3 LB. CAN **7.99**

30% OFF LABEL CLING FREE
54 CT. **2.59**

DOUBLE *Cash Dividends* FOR SENIOR CITIZENS

Cash Dividend SPECIAL

OPEN PIT BARBECUE SAUCE
1-LB. 12-OZ. BTL. **69c**
WITH 1 FILLED CASH DIVIDEND CERTIFICATE

Cash Dividend SPECIAL

ASSORTED FLAVORS DUNCAN HINES CAKE MIXES
1-LB. 2 1/2-OZ. BOX **29c**
WITH 1 FILLED CASH DIVIDEND CERTIFICATE

Cash Dividend SPECIAL

MASTER BAKERS HAMBURGER or HOT DOG BUNS
8-CT. PKGS. **2.5c**
WITH 1 FILLED CASH DIVIDEND CERTIFICATE

CHATHAM SENIOR CITIZENS
PRESENT THIS CERTIFICATE AND RECEIVE **DOUBLE Cash Dividends**

NAME: _____
ADDRESS: _____
CITY: _____

If you are 65 or older, redeem this certificate and get two (DOUBLE) Cash Dividend Coupons for each dollar you spend, excluding alcohol & tobacco products. Proof of age required. Offer expires June 22, 1982.

DUNCAN HINES BLUEBERRY (13-OZ.) or BRAN MUFFIN MIX
9 3/4-OZ. PKG. **1.29**

INSTANT COFFEE MAXWELL HOUSE
10-OZ. JAR **4.59**

ORVILLE REDENBACHER POPCORN
1-LB. 14-OZ. **2.19**
ORVILLE REDENBACHER OIL 12-OZ. 1.48

SMUCKER'S STRAWBERRY JAM
1-LB. JAR **2.177**

KRAFT DRESSINGS
• CATALINA
• CREAMY CUCUMBER
• FRENCH
• THOUSAND ISLAND
8-OZ. **66c**

Clean & Save!
GLAD TRASH BAGS 20 CT. **2.49**

35% OFF LABEL FRESH START
34 1/2-OZ. **3.19**

ALL GRINDS MAXWELL HOUSE COFFEE
2 LB. CAN **4.88**

35% OFF LABEL DOWNY SOFTENER
HALF GAL. **2.29**

WHITE CLOUD TISSUE
4 ROLL PKG. **1.49**

POST RAISIN BRAN
1-LB. 4-OZ. **1.93**

RINSO DETERGENT
4-LBS. 8-OZ. **1.99**

CHATHAM

DOUBLE ON 5 MANUFACTURER COUPONS

ALL IT TAKES IS ONE FILLED CASH DIVIDEND CERTIFICATE

All coupons over 50¢ will be redeemed at face value. Amount to be refunded cannot exceed the cost of the coupon item. Limit 1 coupon for any 1 product. Retail store coupon and Free coupons excluded.

world wide deli

HOME OF VARIETY, FRESHNESS, VALUE

BAR-B-Q FAVORITE
NATURAL CASING
HOT DOGS.....

2.69
LB.

TASTY
CHICKEN
ROLL.....

HALF
LB. **1.39**

ECKRICH
ALL MEAT
BOLOGNA.....

HALF
LB. **1.49**

FRESH
CREAMY
COLE SLAW.....

LB. **88¢**

BAKERY

MASTER BAKERS
SLICED
WHITE
BREAD

2.88
1-LB.
4-OZ.
LOAVES

MULTI PACK
HOSTESS TWINKIES 10 CT. PKG. **1.09**

ASSORTED FLAVORS
McMILLAN BRAND
FRUIT
PIES

4.01
4-OZ.
PIES
FOR

FRESH GOV'T INSPECTED
PORK STEAK
1.38
4 TO 6 LB. AVG.
LB.

KENTUCKY BRAND SALE
KENTUCKY BRAND
MEAT HOT DOGS
2.198
2 LB. PKG.
SLICED BOLOGNA LB. 1.49 (BEEF 1.69)

U.S. GRADE A FRESH
COUNTRY PRIDE
CHICKEN WINGS OR CHICKEN THIGHS
77¢
3 TO 5 LB. AVG.
LB.

U.S. GRADE A FRESH
COUNTRY PRIDE
WHOLE FRYERS
58¢
SAVE 21¢ LB.
LB. LIMIT 1 PLEASE

FULLY COOKED
THORN APPLE VALLEY
SEMI-BONELESS HALF HAM
1.69
WATER ADDED
LB.

FRESH, GAUDINO
ITALIAN or POLISH SAUSAGE
1.99
LB.

FRESH CUT, BEEF BOTTOM
BONELESS ROUND STEAK
2.28
4 TO 6 LB. AVG.
LB.

100% HAMBURGER
BEEF PATTIES
1.89
2 TO 3 LB. AVG.
LB.

JENNIE-O
WHITE TURKEY ROAST
2.299
2 LB. BOX

JENNIE-O
WHITE/DARK TURKEY ROAST
2.249
2 LB. BOX

FRESH GROUND
MEAT LOAF MIX
1.59
ANY SIZE PKG.
LB.

FRESH FROZEN
BEEF LIVER
88¢
LB.

Cash Dividend SPECIAL
KRAFT
PHILADELPHIA CREAM CHEESE
33¢
8-OZ. PKG.
WITH 1 FILLED CASH DIVIDEND CERTIFICATE

Cash Dividend SPECIAL
GRADE A FRESH
LARGE EGGS
29¢
DOZ. CTN.
WITH 1 FILLED CASH DIVIDEND CERTIFICATE

Thorn Apple Valley Values
SLICED BACON
1.59
12-OZ. PKG.
Thorn Apple Valley Smoked Sausage or Polish Kielbasa **2.49**
Thorn Apple Valley Chunk Brunschweiger or Liverwurst **1.79**
Thorn Apple Valley Meat Hot Dogs **1.79**
Thorn Apple Valley Long Dogs **2.39**

FRESH LAMB SALE
LAMB SHOULDER BLADE ROAST
1.39
LB.
LAMB SHOULDER BLADE CHOPS
1.77
LB.
LAMB SHOULDER ROUND BONE CHOPS
1.87
LB.

HYGRADE BALL PARK MEAT FRANKS LB. 1.79 (BEEF 1.99)

ALL BEEF, VEAL & LAMB SOLD IN DETROIT IS U.S.D.A. CHOICE

DOUBLE ON 5 MANUFACTURER COUPONS

GREEN GIANT SINGLE SERVE ENTREES



GREEN GIANT LASAGNA

109

12-OZ.

GREEN GIANT SALISBURY STEAK 14-OZ. 169

GREEN GIANT STUFFED GREEN PEPPERS 14-OZ. 169

GREEN GIANT STUFFED CABBAGE 14-OZ. 169

VAN DE KAMP BATTERED FISH FILLETS

299

1-LB. 8-OZ.

CHILLY BUBBLE GUM POP 6 PK. 99¢

TROPICANA ORANGE JUICE

109

12-OZ. CAN

FROZEN CHATHAM LEMONADE

49¢

12-OZ. CAN

BANQUET BREAD DOUGH

149

5 PK.

COOKIES & CREAM, CHOCOLATE DROP LADY BORDEN ICE CREAM

269

HALF GAL.

Father's Day Specials!

36 POSITION CHAISE LOUNGE

999

SAVE \$2.00

WITH PLASTIC HANDLES LAWN CHAIR

799

MENS, HI-RISE ORLON CREW SOCKS

99¢

ORE IDA SHOESTRING POTATOES

159

2-LB. 8-OZ.

ALL IT TAKES IS ONE FILLED Cash Dividend CERTIFICATE

All coupons over 50¢ will be redeemed at face value. Amount to be refunded cannot exceed the cost of the coupon item. Limit 1 coupon for any 1 product. Retail store coupon and Free coupons excluded.

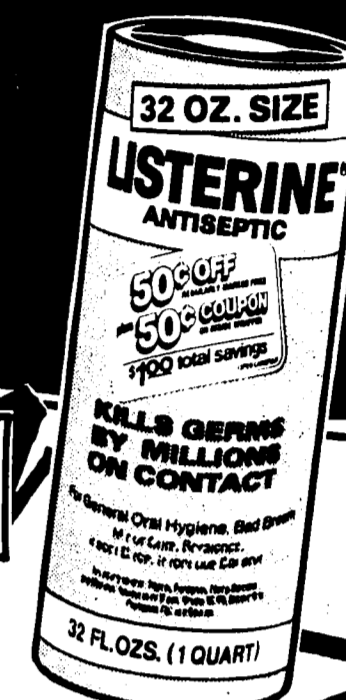

SAVE 70¢

EVERFRESH ORANGE JUICE

99¢

HALF GALLON

ANTISEPTIC LISTERINE MOUTHWASH

CHATHAM LOW SALE PRICE 1.79

LESS MANUFACTURERS STORE COUPON IN JUNE 16 DETROIT NEWS & FREE PRESS -30

You Pay Only 149

ASSORTED FLAVORS BORDEN'S FRUIT DRINKS

89¢

GAL. JUG

IN QUARTERS KEYKO MARGARINE

49¢

1-LB. PKG.

ASSORTED FLAVORS DANNON MELANGE YOGURT

3 \$1

6-OZ. CTNS.

LAND O' LAKES SINGLES

199

1-LB. PKG.

NATALINA PEPPERONI PIZZA

269

1-LB. 9-OZ.

20¢ OFF LABEL

SAVE 40¢

GILLETTE ATRA BLADES

5 CT. 157



SEE IN STORE FOR YOUR ALL STAR BASEBALL BALLOT

OLD SPICE STICK DEODORANT

129

2.5-OZ. REGULAR OR MUSK

SAVE 34¢



BARBASOL SHAVE CREAM

79¢

11-OZ. MENTHOL, REGULAR, LIME

MONTH LONG

Cash Dividend

WITH 1 FILLED CASH DIVIDEND CERTIFICATE
Regular or Natural

Mott's Apple Juice HALF GAL. **1.28**

Tang

French's Mustard 1-LB. 8-OZ. **29c**

Fresh in our Dairy

Kraft Orange Juice HALF GAL. **1.38**

Yellow & Black Label

Barbecue Sauce 1-PT. 2-OZ. **6c**

Assorted

Ralston Cereals 12-OZ. **89c**

Creamy or Crunchy

Chatham Peanut Butter 1-LB. 2-OZ. **88c**

Yellow & Black Label

Sandwich Bags 150 CT. **6c**

Chatham

Pork & Beans 2-LB. 8-OZ. **38c**

Assorted Flavors (Plus Deposit)

2 Liter Faygo Pop 2-LITER BTL. **49c**

Instant

Idahoan Potatoes 5-OZ. PKG. **9c**

Bonus Pack, Tall

Hefty Kitchen Bags 17-CT. **84c**

Absorbent

Delta Towels 85-FT. ROLL **9c**

Powdered, Light, Dark

Plantation Sugar 2-LB. POLY BAG **37c**

Chatham

Tea Bags 100-CT. **99c**

Progresso, Italian

Bread Crumbs 15-OZ. CAN **38c**

Wide or Broad

Dutch Maid Noodles 1-LB. PKG. **19c**

Detroit City

Ice Cubes 5-LB. BAG **9c**

Oro Ida, Frozen

Hash Browns 12-OZ. **9c**

Mr. P's Combination or

Pepperoni Pizza 10-OZ. PKG. **29c**

Dairy Whip

Ice Milk HALF GAL. **99c**

Processed Cheese Slices

Chatham Singles 12-OZ. PKG. **99c**

Chatham

English Muffins 6-CT. PKG. **5c**

Tasty

Shedd's Spread 2-LB. PKG. **69c**

Coppertone

Lotion or Oil 8-OZ. BTL. **3.07**

Regular Strength

Chatham Non-Asprin 100-CT. **99c**

Spice, Regular or Herbal

Mennen Speed Stick 2.5-OZ. **99c**

All Meat

Peschke Bologna 1 1/2-LB. PKG. **1.99**

Mr. Turkey

Ground Turkey 1-LB. PKG. **49c**

Bonnie Maid

Breaded Veal Patties LB. **89c**

Land-O-Frost

Sliced Meats 2 1/2-OZ. PKG. **FREE**

SPECIALS

**TRIPLE
Cash
Dividends
ON ALL
PRODUCE
PURCHASES
NOW THRU JUNE 22**

**RED RIPE
FRESH
BANANAS**

28c

**SWEET JUICY
HONEYDEW
MELONS**

77c

EA.

**PERLETTE WHITE U.S. NO. 1
SEEDLESS
GRAPES**

1.39

**RED RIPE U.S. NO. 1
CHERRY
TOMATOES**

88c

**TART U.S. NO. 1
GRANNY SMITH
APPLES**

88c



Prices Effective at This A&P Store Only

41800 WEST TEN MILE
NOVI

OPEN 24 HOURS
8 A.M. MON. TO 11 P.M. SAT.
SUNDAY 9:30 A.M. TO 9 P.M.



Each of these advertised items is required to be readily available for sale at or below the advertised price in each A&P Store, except as specifically noted in this ad.

Prices effective thru Saturday, June 19, 1982. Items offered for sale not available to other retail dealers or wholesalers. We reserve the right to limit quantities.

Supplement to the
Novi News, Wed., June 16, 1982

ASSORTED
Pork Chops
\$14.98
10-lb. pkg.

NEW CROP-TEXAS

Honeydew Melons

LIMIT THREE

69¢
each

SAVE \$1.30

LUNCH BOX TREAT
Golden Ripe Bananas
28¢
lb.

48" TO 72" TALL ASSORTED VARIETIES

Show Plants

10-inch pot

\$9.97

FRESH - NO BACKS

Fryer Legs

10-lb. pkg. **\$5.98**

4 BIG DAYS
WED., JUNE 16
THRU
SAT., JUNE 19

ALL PURPOSE

Potting

Soil

20 lb. bag **\$1.97**

RICH, BLACK

Michigan Peat & Top Soil

25 lb. bag **\$1.28**

1/4-BARREL SIZE WITH HANDLES
Whisky Barrel Planters

each **\$9.97**

U.S. No. 1 CALIFORNIA

Long White Potatoes

8 lb. bag **\$1.88**

SAVE \$1.09

HAMBURGER MADE FROM
Ground Chuck
\$14.98
10-lb. pkg. U.S.D.A. CHOICE GRADE BEEF

SUN-BLUSHED CALIFORNIA
Nectarines

69¢
lb.

ASSORTED BASKETS
Handling Baskets
TENDER
CORN
CUCUMBERS
PEAS
COMBINATION
PLANTERS
PREPARED
HARDWOOD
MISCELLANEOUS

P Meat Specials

Boneless Chuck Steak
\$16.98
10-lb. pkg. U.S.D.A. CHOICE GRADE BEEF

WILLIAMSBURG
Sliced Bacon
\$15.98
10-lb. pkg.

P Produce Specials

SUGAR SWEET
Whole Watermelon
\$1.97
each SAVE \$1.83 18-LB. AVERAGE

P Grocery Specials

REG. & SUGAR FREE SPRITE, DR. PEPPER, MELLO-YELLO, SUNKIST ORANGE, TAB, SQUIRT OR

Coca-Cola
8 \$1.99
1/2-liter btl. PLUS DEPOSIT

CASE OF 24 BOTTLES \$5.79 PLUS DEP.

YUM-YUM POTATO CHIPS 3-OZ. BAG **89¢**



ADVERTISED ITEM POLICY Each of these advertised items is required to be readily available for sale at or below the advertised price in each A&P Store, except as specifically noted in this ad. Prices effective thru Saturday, June 19, 1982. Items offered for sale not available to other retail dealers or wholesalers. We reserve the right to limit quantities.

REDEEM ALL 3 COUPONS WITH ONE \$10 PURCHASE

SUPER COUPON
ALL VARIETIES
Duncan Hines Cake Mix... 49¢
One 18-oz. Box
LIMIT ONE WITH THIS COUPON AND ADDITIONAL \$5 PURCHASE
LIMIT ONE COUPON PER CUSTOMER
VALID THRU SATURDAY, JUNE 19, 1982

SUPER COUPON
IN OIL OR WATER
CHUNK LIGHT
Star Kist Tuna... 49¢
One 6-oz. Can
LIMIT ONE WITH THIS COUPON AND ADDITIONAL \$5 PURCHASE
LIMIT ONE COUPON PER CUSTOMER
VALID THRU SATURDAY, JUNE 19, 1982

SUPER COUPON
QUARTERED
Imperial Margarine... 39¢
One 1-lb. Ctn.
LIMIT ONE WITH THIS COUPON AND ADDITIONAL \$5 PURCHASE
LIMIT ONE COUPON PER CUSTOMER
VALID THRU SATURDAY, JUNE 19, 1982

Guaranteed Value



Quality Guaranteed Value
Our Pledge
WE UNCONDITIONALLY GUARANTEE THE QUALITY OF EVERYTHING WE SELL OR YOUR MONEY BACK. AND WE'RE SO SURE OF THE QUALITY OF OUR MEATS, PRODUCE AND DELI PRODUCTS, WE'LL DOUBLE YOUR MONEY BACK WITH PROOF OF PURCHASE IF YOU ARE NOT SATISFIED WITH THESE ITEMS.
PRICE: IF ANOTHER SUPERMARKET'S CURRENT NEWSPAPER ADVERTISED PRICE IS LOWER THAN OUR ADVERTISED PRICE ON AN IDENTICAL ITEM, JUST BRING IN THE AD AND WE WILL MATCH THE PRICE.
*EXCLUDING ITEMS REQUIRING COUPONS, STORES OR RESTAURANTS.
PRICE & QUALITY = VALUE
Guaranteed Value

P&Q Specials
P&Q Bath Tissue 4 69¢
roll pkg.

- Facial Tissue 200-ct. box **53¢**
- Paper Plates 100-ct. pkg. **99¢**
- Cold Cups 100-ct. pkg. **\$1.39**
- Pine Cleaner 15-oz. btl. **89¢**

P&Q Specials
P&Q Paper Towels 2 \$1
jumbo rolls

- Ketchup 32-oz. btl. **95¢**
- Liquid Bleach gal. jug **69¢**
- Fruit Cocktail 16-oz. can **59¢**
- Kosher Dill Spears 24-oz. jar **99¢**

P&Q Specials
P&Q White Bread 39¢
20-oz. loaf

Grocery Specials
REGULAR OR SUGAR FREE SPRITE, DR. PEPPER, TAB, SQUIRT, MELLO-YELLO, SUNKIST ORANGE OR
Coca-Cola 8 \$1.99
1/2-liter btl. PLUS DEPOSIT

- Grocery Specials**
- READY TO SPREAD Betty Crocker Frostings 16.5-oz. can **\$1.47**
 - FRUIT PUNCH, ORANGE, GRAPE OR PEACH Hi-C Fruit Drinks 48-oz. can **69¢**
 - Stokely Applesauce 16 1/2-oz. can **39¢**
 - KEEBLER Zesta Saltines 16-oz. box **89¢**
 - FOUR FLAVORS - REDUCED CALORIE Kraft Dressings 9-oz. btl. **\$1.50**
 - SHOWBOAT Pork and Beans 42-oz. can **99¢**
 - DOLE Pineapple Juice 46-oz. can **\$1.29**
 - DECAFFEINATED COFFEE Hills Bros. Instant 13-oz. jar **\$3.29**

Grocery Specials
30-GALLON SIZE
Glad Trash Bags \$1.29
10-ct. box
3-PLY GLAD TRASH BAGS 20-CT. BOX **\$2.29**

- Grocery Specials**
- CHEF BOY-AR-DEE BEEF OR Mini Ravioli 15-oz. can **79¢**
 - KRAFT DRESSING Miracle Whip 48-oz. jar **\$2.29**

The Butcher Shop
With Supermarket Prices

U.S.D.A. CHOICE BEEF
Bottom Cut Boneless Round Steak \$1.88
lb.
BONE IN Whole New York Strips \$2.98
lb.
BONELESS NEW YORK STRIPS **\$3.98**
lb.

Meat Specials
NO BACKS Fresh Fryer Breasts 98¢
lb.
NO BACKS - FRESH FRYER LEGS **68¢**
lb.

Deli Specials
AVAILABLE ONLY AT STORES W/DELI-BAKE SHOP
SLICED TO ORDER
Virginia Baked Ham \$1.79
1/2-lb.

- 8 PIECE BUCKET Fried Chicken each **\$2.99**
- NEW YORK TURKEY OR Chicken Roll 1/2-lb. **69¢**
- FAMILY FAVORITE Hawaiian Salad lb. **99¢**
- CREAMY OR MUSTARD Potato Salad lb. **69¢**
- GREAT ON SANDWICHES Baby Swiss Cheese 1/2-lb. **\$1.49**

BONELESS U.S.D.A. CHOICE Rump Roast \$1.88
lb.

HICKORY HOST Boneless Hams \$1.68
lb.

FRESH FRYER PARTS
Box-O-Chicken 49¢
lb.
FRESH Pork Picnics 98¢
lb.
WILLIAMSBURG Sliced Bacon \$1.69
1-lb. pkg.

Dairy Specials
HOMOGENIZED Borden's Milk \$1.79
gallon carton

Frozen Specials
BUY ONE GET ONE FREE
15-OZ. PKG. - PEPPERONI OR COMBINATION
Jeno's Extra Topping Pizza
BOTH FOR ONLY \$1.99 WITH-IN STORE COUPON

- THORN APPLE VALLEY SMOKED OR POLISH Sausage 1-lb. **\$2.28**
- THORN APPLE VALLEY FAMILY PAK - 200g. PKG. Luncheon Meats **\$2.28**
- ECKRICH REGULAR OR THICK SLICED Bologna 1-lb. **\$2.39**
- PESCHKE Ring Bologna lb. **\$1.78**
- FROZEN Steak Tonight 1-lb. **\$1.98**
- THORN APPLE VALLEY CHICKEN BOLOGNA OR Hot Dogs 1-lb. **\$1.18**
- MEAT, BEEF OR CHEESE OSCAR WAYER Franks 1-lb. **\$2.18**
- OLE VIRGINIE Pork Sausage 1-lb. **78¢**
- AAP FROZEN Fried Chicken 1-lb. **\$2.18**
- SHENANDOAH BONELESS Turkeys 1-lb. **\$1.49**

- Dairy Specials**
- KRAFT PHILADELPHIA Cream Cheese 8-oz. pkg. **97¢**
 - SOFT MARGARINE Land O Lakes 1-lb. pkg. **99¢**
 - A&P CHILLED Orange Juice 64-oz. btl. **\$1.89**
 - BUTTERMILK OR COUNTRY STYLE Pillsbury Biscuits 7.5-oz. tube **27¢**
 - NEW! FROM KRAFT Velveeta Sliced Cheese 12-oz. pkg. \$1.69**

- Frozen Specials**
- SIX VARIETIES Banquet Dinners 11 to 12-oz. pkg. **79¢**
 - REGULAR OR CRINKLE CUT A&P French Fries 2-lb. pkg. **79¢**
 - POTATO/CHEESE Mrs. T's Pierogies 16-oz. pkg. **\$1.25**
 - PINK OR YELLOW Ann Page Lemonade 12-oz. can **49¢**
 - CONCENTRATED Tropicana Orange Juice 12-oz. can **\$1.09**

Frozen Specials
ALL FLAVORS
Breyers Ice Cream \$2.49
1/2-gal. ctn.
FOUR FLAVORS Magic Shell Topping 7-oz. **\$1.59**
ALL FLAVORS - FROZEN Sealtast Yogurt quart. **\$1.39**

HBA Specials
9-PIECE TOOL SET
Stanley 'Super Doers' \$8.88
set

- Crest Toothpaste \$1.89**
8.2-oz. tube
- JOHNSON & JOHNSON Baby Shampoo 16-oz. btl. **\$2.79**
- Scope Mouthwash 18-oz. btl. **\$1.89**

Grocery Specials
CHARLIS, BLANC, PINK CHARLIS OR RHINE GALLO WINES 1.5-LITER BTL. **\$3.49**
Stroh's Beer \$5.29
12 12-oz. cans PLUS DEPOSIT



ADVERTISED ITEM POLICY Each of these advertised items is required to be readily available for sale at or below the advertised price in each A&P Store, except as specifically noted in this ad.

Prices effective thru Saturday, June 19, 1982. Items offered for sale not available to other retail dealers or wholesalers. We reserve the right to limit quantities.

THE FARM

AT A&P

CALIFORNIA WHITE

Seedless Grapes

First of the Season

lb. **97¢**

Guaranteed Value

NEW CROP! TEXAS

Honeydew Melons

SAVE \$4.30

each **69¢**

LIMIT THREE

U.S. No. 1 — CALIFORNIA

Long White Potatoes

8 lb. bag **\$1.88**



LUNCH BOX TREAT

Golden Ripe Bananas

lb. **28¢**



U.S. No. 1 — TEXAS

Yellow Onions

lb. **28¢**

SAVE 29¢

AFRICAN VIOLETS \$1.49 ea.

WIN A FLORIDA VACATION

Stay at the **BEACH COMBERS** Resort Motel, St. Petersburg, FL

- EACH FLORIDA TRIP IS FOR FOUR PERSONS AND INCLUDES THE FOLLOWING:
- 4 Days and 3 Nights at the Beach Combers Resort Motel, St. Petersburg Beach (meals not included).
 - Admission Tickets to Florida's Busch Gardens, Tampa
 - Round Trip Air Transportation (from Detroit Metro Airport to Tampa, Florida via Eastern).
 - Free Rental Car for the Whole Trip

Visit... **The Dark Continent: Busch Gardens, Tampa**

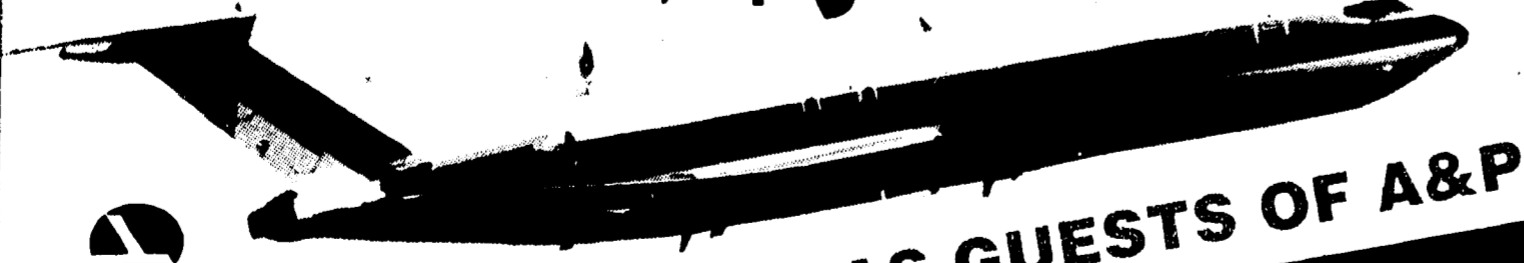

FLY EASTERN AS GUESTS OF A&P

WIN ONE OF 3 FLORIDA VACATIONS FOR 4 PEOPLE

- HERE'S HOW TO ENTER**
- Fill out official entry blank. Deposit it at any A&P Store or mail to the address shown on the entry blank. Envelope must be postmarked by Sat., June 19, 1982. Additional entry blanks are available at any A&P Store. No purchase necessary.
 - All persons 18 years of age and older are eligible except employees of The Great Atlantic & Pacific Tea Co., or agents and their families.
 - The second weekly drawing will be held Friday, June 25, 1982. Last weekly drawing will be held on next Friday. Winners of vacations will be notified by telephone. All prizes will be awarded. Vacation winners must take trip before December 31, 1982.
 - The chances of winning a prize depends on the number of entries we receive in 63 A&P Stores and in the mail. Winning prizes are not transferable.

A&P OFFICIAL ENTRY BLANK
A&P FLORIDA SWEEPSTAKES
Fly Eastern • Visit Busch Gardens

PRINT CLEARLY

Name _____

Address _____

City _____

State _____

Zip _____

Deposit at any A&P store or mail to:
The Great Atlantic & Pacific Tea Co., P.O. Box 517, Southfield, Mich 48034
No purchase necessary. You need not be present to win.

gifts to make Father's Day!

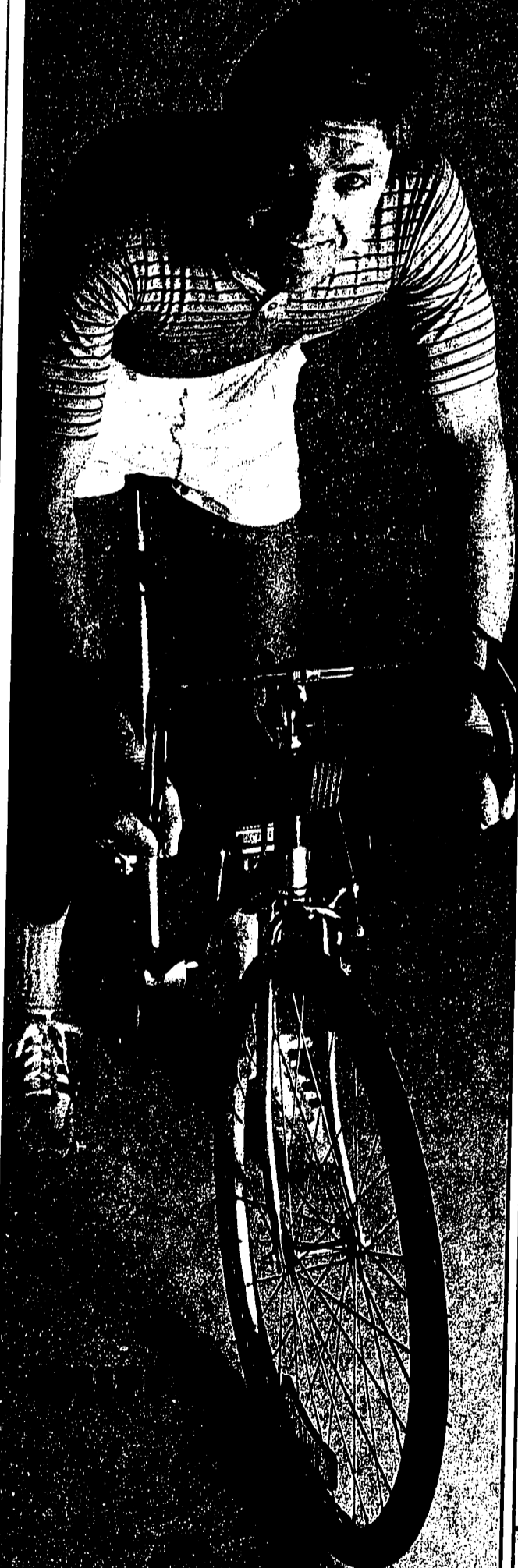

save 13.91
 The new Camera Bicycle Seat. Available in black, white, silver, gold and fast. Features a built-in camera system. Dual caliber. 26" wheels. 21" frame. 26" handlebar. 26" seat. Reg. 103.88

11.77
Hibachi On Stand Enjoy tasty charcoal flavor only a Hibachi can provide! It's cast iron on a 23" metal tube stand. 12 x 16" cooking grid. #8100

Men's Cambridge Cologne or After Shave The gentleman's fragrance with a crisp, English accent! Cologne or After Shave, 4 oz. each

Cologne 7.33
After Shave 5.97

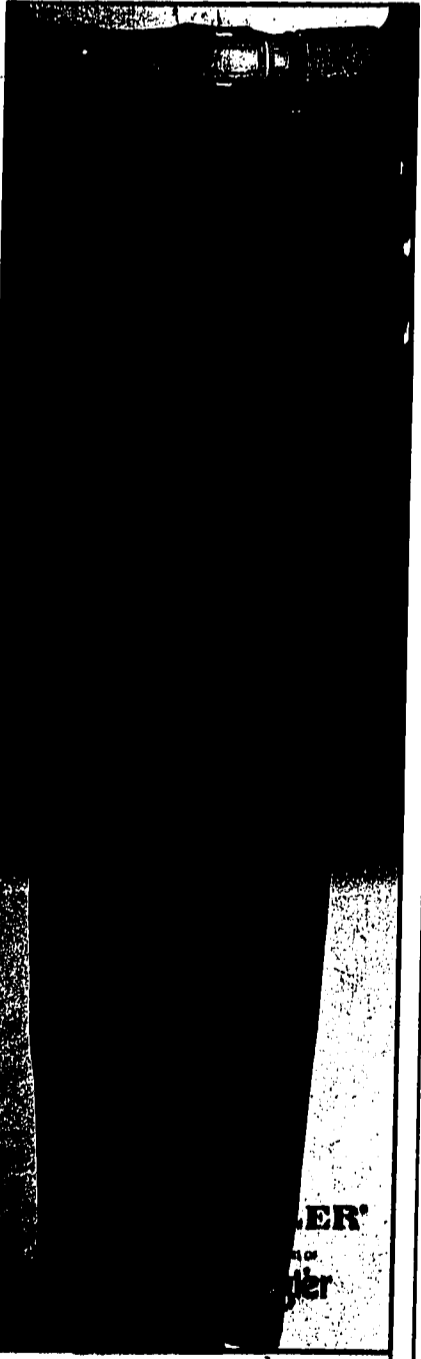

11.00 save 3.97
Wrangler Young Men's Fashion Denim Jeans Rustler brand from the makers of Wrangler. 100% cotton, 11 1/2 oz. dark blue denim. Assorted back pocket treatments and stitching. Boot cut. Sizes 27-36. Reg. 14.97

2 \$5 FOR
Kodak Kodacolor Film For sharp, clear prints. C-135, 36 exposures. Limit 2

save 36%
2.97
BASF Tapes Buy two, get one free... three 60 min. blank tapes. Reg. 4.67. Limit 2

Unisonic
8.96
Unisonic Pen Watch Features month, date, hours, minutes and seconds! Silver with gold tone trim. Boxed #PW72A

29.96 save 19.01
AM/FM Radio with Cassette Recorder Auto-stop, telescopic antenna. Batteries not included. AC/DC. #E711. Reg. 48.97

20% OFF
Manufacturer's suggested sale price

TIMEX
Men's Timex Ultra Thin Digital Watches Feature new, long life battery! In gold or silver tones with leather or sliding clasp bands

TG&Y family centers

SALE IN EFFECT SUN., JUNE 13 THRU SAT., JUNE 19
 At Those Locations Where TG&Y is Closed On Sundays. Sale in Effect Mon., June 14-Sat., June 19

Items Available In TG&Y Family Centers Only

The right gift for Dad requires that certain know how!



Mr. Scott

8.97 save 2.91

Men's Long Sleeved Dress Shirts Give Dad that image and feeling of confidence with the Oxford cloth look. 60% cotton/40% polyester. In assorted colors. Sizes 14 1/2-17 neck, 32-35 sleeve. Reg. 11.88

11.88 save 5.00

Men's Dress Slacks Complete Dad's distinctive looks with these textured, woven 100% polyester dress slacks. Dapper and easy to care for in assorted colors. Sizes 30-40. Reg. 16.88



3.00 save 40%

Men's Short Sleeved Dress Shirt For the Father who has a preference for short sleeves. Give him the trim look of easy care 65% polyester/35% cotton in assorted solid colors. Sizes 14 1/2-17 neck. Reg. 4.97

8.97 save 3.00

Men's Knit Shirt For sporting good looks. 60% cotton/40% polyester. Assorted colors. Sizes S-XL. Reg. 11.97

TG&Y family centers

\$3 Refund
By mail from Hanes when you buy any 6 Hanes underwear garments for men or boys.
*See store display for details.

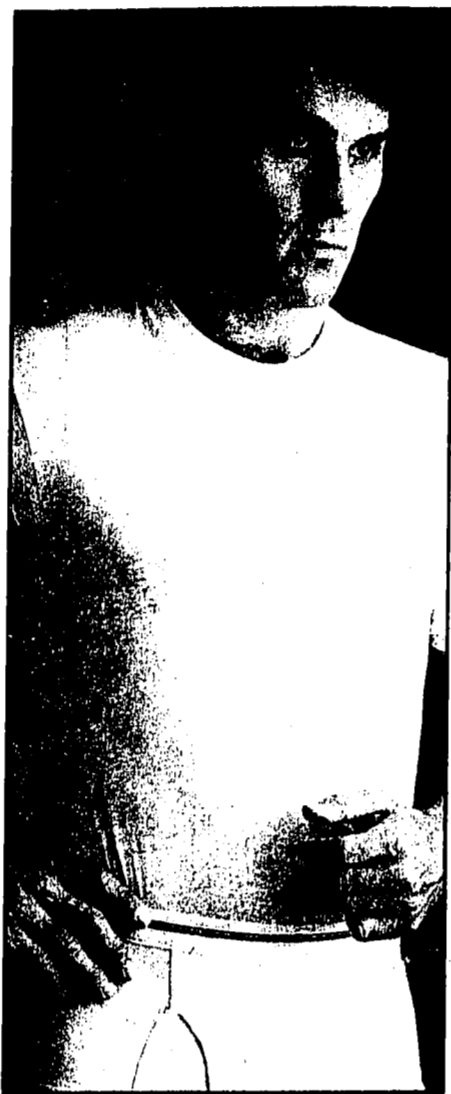

Hanes Men's T-Shirts or Briefs Make a hit with Dad. Give him comfortable 100% cotton T-shirts or briefs. Sizes S-XL. 3 per package.

T-Shirt Reg. 6.27 **4.97** save 21%

Briefs Reg. 5.57 **4.97**



1.16 pr. save 26%

Men's Crew Socks Hi-bulk 80% Bi-loft Orion® acrylic/20% nylon. Dark brown, navy blue or black. Sizes 10-13. Reg. 1.57

*Orion® is a registered trademark.



Items Available In TG&Y Family Centers Only

The sporting good life for Dad this Father's Day



11.97 save 3.00

Men's Wrangler Knit Shirt Quite the right stripe... of the rugby variety. Accented with a fashion knit collar. Buy one for Dad! 50% polyester/50% cotton. Assorted colors in sizes S, M, L or XL. Reg. 14.97



9.97 save 3.00

Men's Knit Shirt Neat and trim with accent shoulder striping. Two styles from which to choose help make a great gift for Father's Day! 80% polyester/20% cotton. In sizes S,M,L or XL. Reg. 12.97

7.97 save 2.00

MacGregor Men's Walking Shorts What the short scene calls for... the belted walking short in assorted solids or plaids. 65% polyester and 35% cotton blend. Sizes 30-38. Reg. 9.97

9.97 save 4.00

Men's Knit Shirt The stripes have it in a new terry jersey fabric! Knit collar with chest pocket. A great choice for Dad. 60% cotton/40% polyester. Assorted colors. In sizes S,M,L or XL. Reg. 13.97

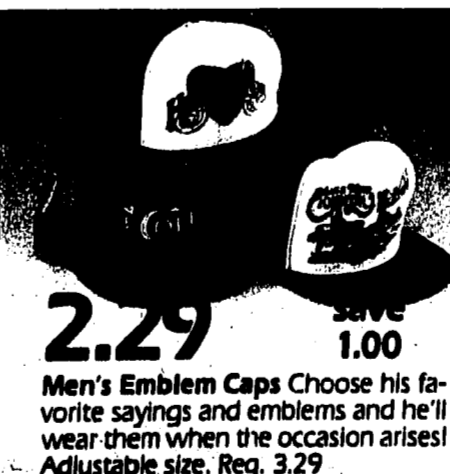

2.29 save 1.00

Men's Emblem Caps Choose his favorite sayings and emblems and he'll wear them when the occasion arises! Adjustable size. Reg. 3.29



10.97

Men's Casual or Dress Belts in assorted colors and sizes to suit your style... and Dad's.



6.96 save 2.03

Men's Wallet and Cologne Set Bill-fold with 1 oz. bottle of English Leather Cologne. Trifold also available. Reg. 8.99



6.99 save 2.00

Men's Trifold Wallet Genuine leather in assorted grains and colors. The perfect Father's Day gift. Reg. 8.99



13.97 save 2.00

Men's Suede Casual Tan with beige stitching and inside vinyl padded collar. Vinyl and tricot lined. Sizes 6 1/2-12. Reg. 15.97



9.97 save 2.00

Men's Leather Thong Let Dad slip into comfort and style. Cinnamon 3 band leather upper. Suede insole. Flexible bottom. Sizes 7-12. Reg. 11.97

TG&Y family centers

Items Available in TG&Y Family Centers Only

Save \$30 on remote control color . . . with 19 inch screen!



369.00 save 30.00

19" Remote Control Color Television Dynamic color on a 185 square inch viewing area with quick start picture and instant sound! Automatic fine tuning and color control, with sensor touch tuning for VHF/UHF channel selection. Six-function, infrared remote control. Twin telescoping VHF antenna. Walnut, wood-grain look cabinet. #E-4816. Reg. 399.00

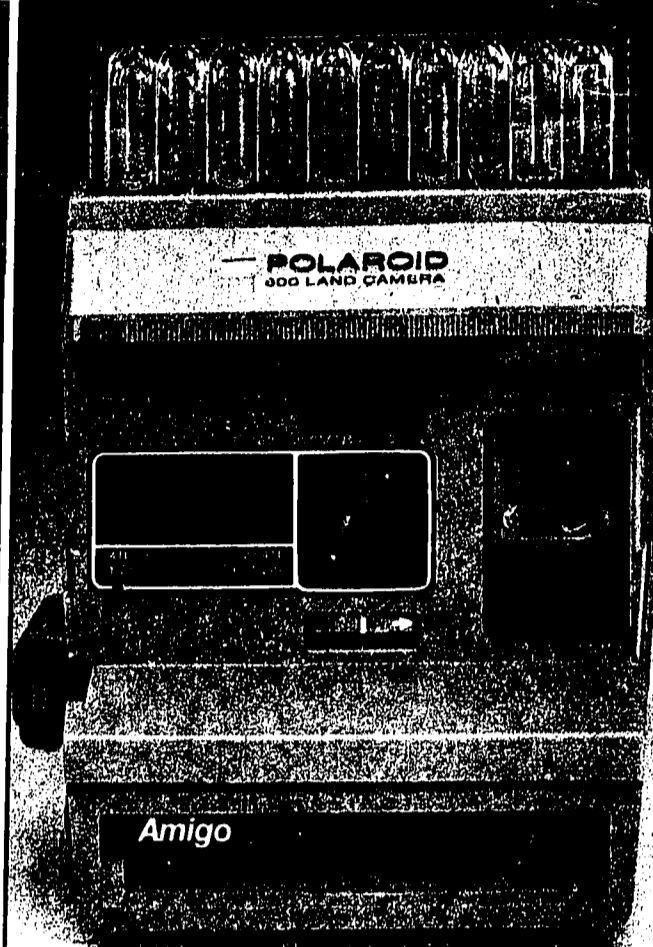

34.96 POLAROID

Polaroid's New Amigo 620 Camera A new Polaroid! It takes pictures no other low-priced instant can with a slide-in, close-up lens that lets you get close . . . instantly! Uses 600 High Speed film. #620.

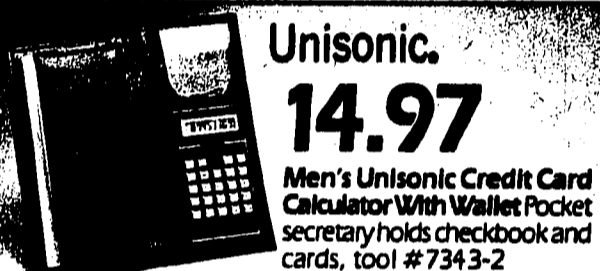

Unisonic.
14.97

Men's Unisonic Credit Card Calculator With Wallet Pocket secretary holds checkbook and cards, tool #7343-2



16.97

Pico Digital Travel Clock The ideal travel mate with easy to read LCD display. #502K

Music to enjoy in your car or at home

Save
During Our Entire Stock Sale On
Records & Tapes



ENTIRE STOCK OF
798 & 898 Series
ALBUMS & TAPES

Reduced
To
Just

6.47

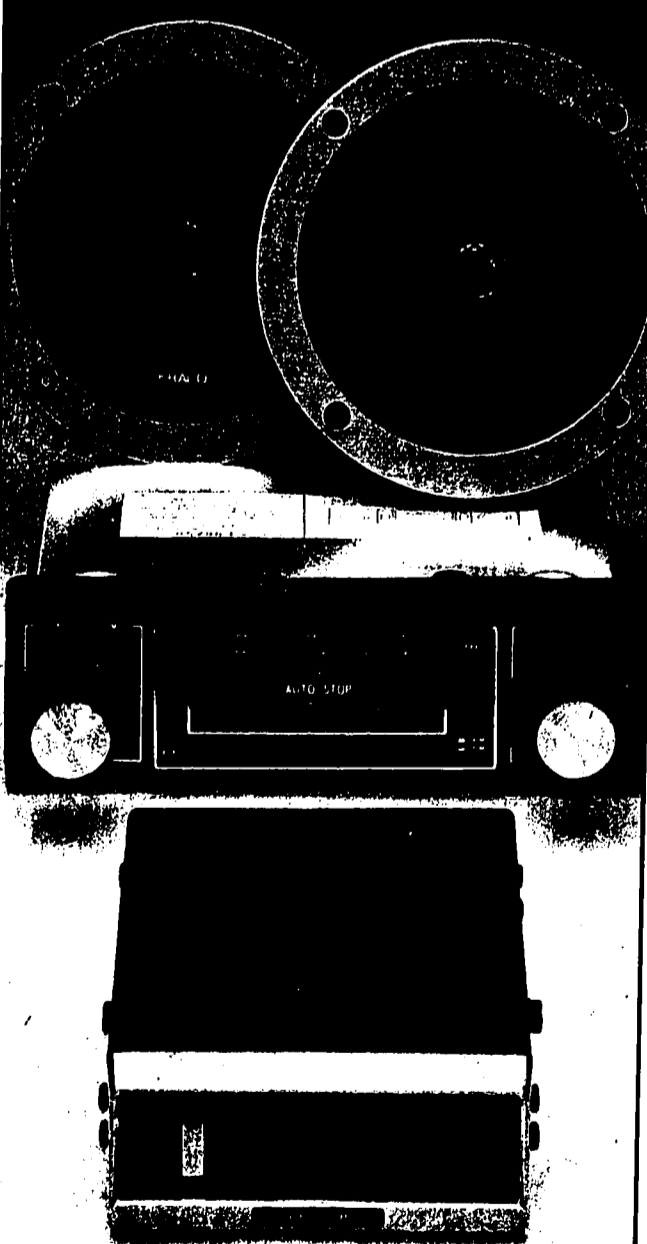

89.00 KRACO

Kraco Total In-dash Stereo System A complete system for under \$90.00! AM/FM stereo radio with auto-tune cassette, 40 watt power booster and two, 5" coaxial speakers. All hardware and instructions for easy installation, tool #KAS2

TG&Y family centers

Items Available in TG&Y Family Centers Only

Sit comfortably
with savings



5.47 save 2.50

Lawn Chair Give Dad a comfortable lawn chair and he'll appreciate your thoughtfulness all summer long! He'll like its lightweight aluminum construction with comfortable plastic arms. Multi-color webbing. #L6004. Reg. 7.97

22.99 save 3.88

Black & Decker Benchtop Workmate The conveniently-sized, 16" work center that's multi-versatile! Lightweight, tool #79-023. Reg. 26.87. Limit 2



TC&Y's Low Price Mail-In Rebate*
39.00
-10.00

Your Final Cost
29.99
Black & Decker 7 1/4" Circular Saw Save 10.00! Sturdy steel wrap-around shoe for added support. Two handle surfaces for positive, steady control. #7390

21.88

Black & Decker Spotlifter Comes with wall storage rack for continuous recharging of batteries. #9360



14.87

Hirsh

Cutters Edge Use with your circular saw, router, sabre saw or utility knife to make straight cuts over 8 feet long. Durable extruded aluminum rails and joiner. #TCE96

Maintain your car with savings!

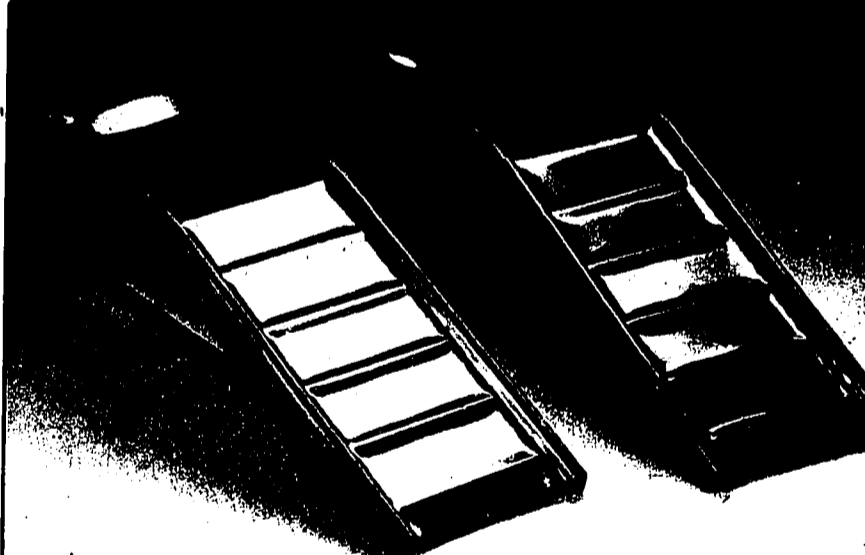

15.99 save 3.80

Kar-Rite Car Ramps Tough one-piece steel construction supports up to 6500 lbs. Lifts wheels 9". Built-in tire stops. #1077. Reg. 19.79



19.96

Everyyoung 4 Wheel Hand Truck Dolly Year 'round hand truck, hauler, yard cart and wood cart is constructed of heavy-duty steel. Folds for compact storage. #EY2109700

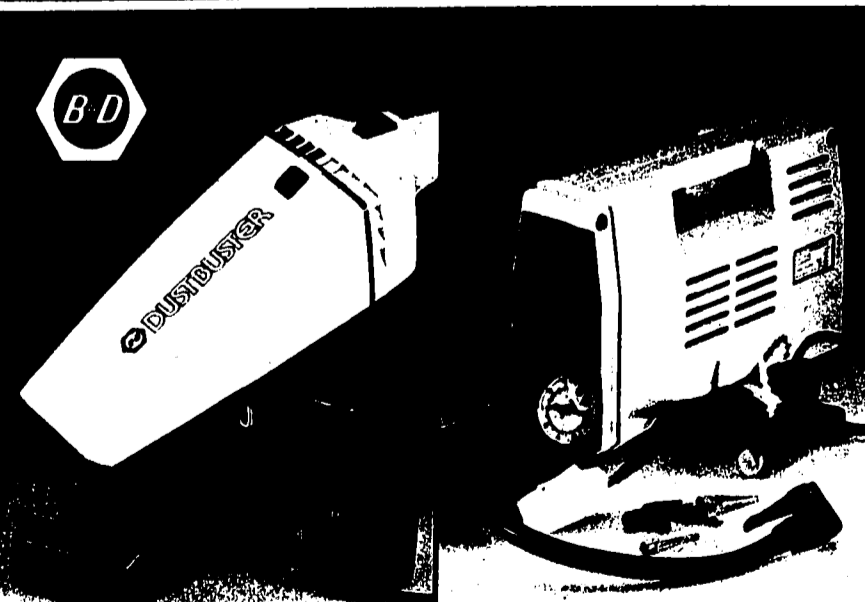

23.94

Black & Decker Dustbuster The cordless rechargeable mini-vacuum is great for quick cleanups! Automatically recharges in handy storage unit. #9330. Reg. 24.97

17.96 save 3.81

Everyyoung 12-Volt Mini Air Compressor 60" long air hose and quick release valve. Includes 2 nozzle adaptors. 12 ft. cord. #EY2104G. Reg. 21.77



.88 save 32%

Plastic Broom and Dust Pan for general cleaning in home, car, shop or camper. Reg. 1.29

9.99 save 3.00

Sportymatic Travelin' Time Auto-Dial Clock No wires to hook up! Battery included. #SCL4. Reg. 12.99

3.33 save 37%

Superior Deluxe Cushion Wheel Cover Padded. One size fits all. Black or tan. Reg. 5.27

TG&Y family centers

Items Available in TG&Y Family Centers Only



Keep savings in sight with Bushnell!

save 10.10
49.88

Bushnell 7x35 Wide Angle Sportview Binoculars Let Dad see all the action with Bushnell! They feature Insta-Focus fast focusing that snaps in the view sharp and clean... Instantly! Roll-down rubber eyecups provide improved viewing with eye or glasses. #13-7362. Reg. 59.98

9.97 **save 3.00**
Wilson Athletic Shirt For Dad's comfort, quality and style, choose Wilson. Easy care 65% polyester/35% cotton. White with navy, red or royal trim. S-M-L-XL. Reg. 12.97

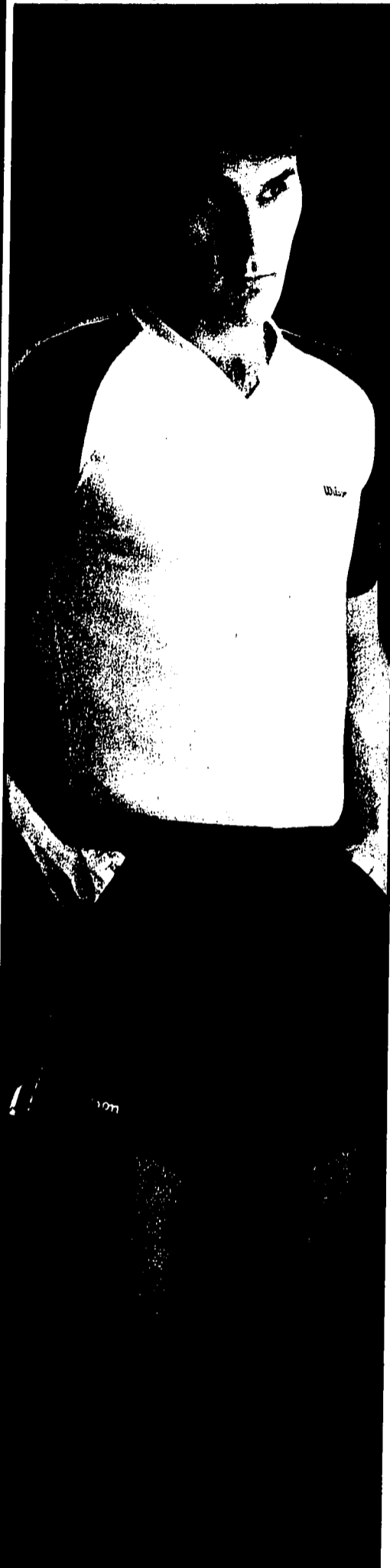



IGLOO
22.88 **save 2.00**

Igloo 48 Quart Ice Chest Fully insulated with high density urethane foam. Sanitary white, seamless ABS plastic inner liner. Tough, high-impact plastic exterior. #70. Reg. 24.88. Limit 2



5.99

Thermos One Gallon Plastic Cooler Picnic ready! Urethane insulation holds temperature all day. Rust-proof, easy to clean molded polypropylene. Sturdy handle. Easy pour spout. #7784. Reg. 7.37



10.97 **save 2.00**

4 Player Badminton Set 4 rackets, 2 poles, net, 2 shuttlecocks and more. #1420. Reg. 12.97

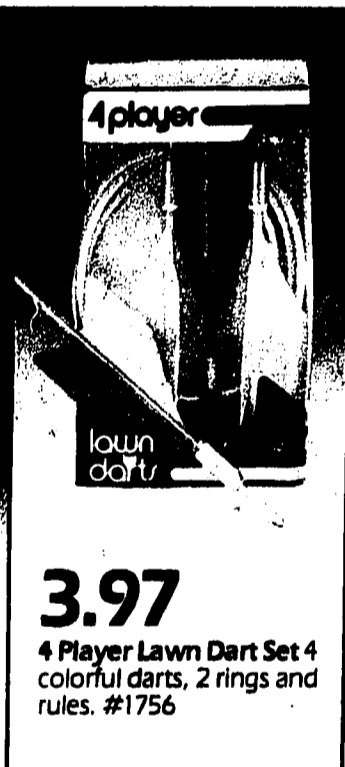

3.97

4 Player Lawn Dart Set 4 colorful darts, 2 rings and rules. #1756

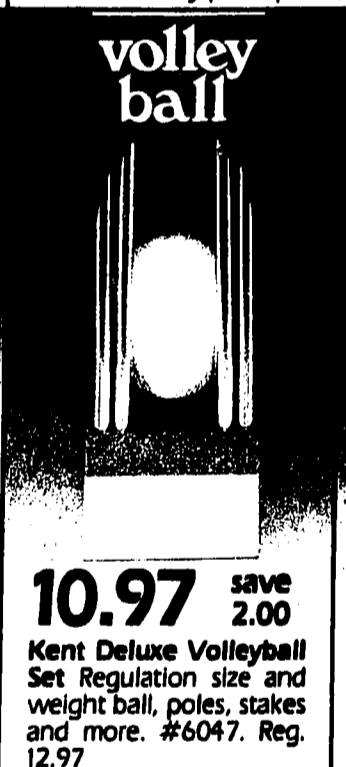

10.97 **save 2.00**

Kent Deluxe Volleyball Set Regulation size and weight ball, poles, stakes and more. #6047. Reg. 12.97



18.97 **save 3.00**

Diversified Products Horseshoe Set Regulation steel shoes and stakes. #25-1103. Reg. 21.97

9.97 **save 3.00**
Wilson Athletic Shorts They look good, play well and stay comfortable. 65% polyester/35% cotton twill. Navy or red with white. S-M-L-XL. Reg. 12.97



22.44

Wrangler 3 Lb. Sleeping Bag Navy nylon shell and red tricot lining with Dac 808 insulation. 34x75" bag with full 94" zipper. #111746



38.00 **save 12.00**

Stag Handle Knife A perfect gift for Dad! This Ka-Bar knife has a 4" stainless steel blade and a long-wearing stag handle. #02-1192. Reg. 50.00

39.99 **save 10.00**
Outdoor Venture Deluxe Hiker Sleeping Bag Ripstop nylon outer cover and inner lining. Filled with 3 lbs. Holioli! 11". 84 x 31 x 21". #887307. Reg. 49.99

4.27
Sport Bag 24" roll bag with nylon zippers and heavy-duty nylon webbing supporting the handles. Water repellent nylon. 24 x 12". #5RS-706. Reg. 4.99

TG&Y family centers

Items Available in TG&Y Family Centers Only



save 5.00
24.97

Zebco 33 Rod and Reel Combo Roll in the big ones with this 6 ft. spincast fiberglass rod and powerful medium freshwater 33 reel. Spring actuated drag system with wide-range control and silent, selective anti-reverse. Includes Premium Trilene XL line. Reel in this substantial Zebco savings! #3490. Reg. 29.97. Limit 2

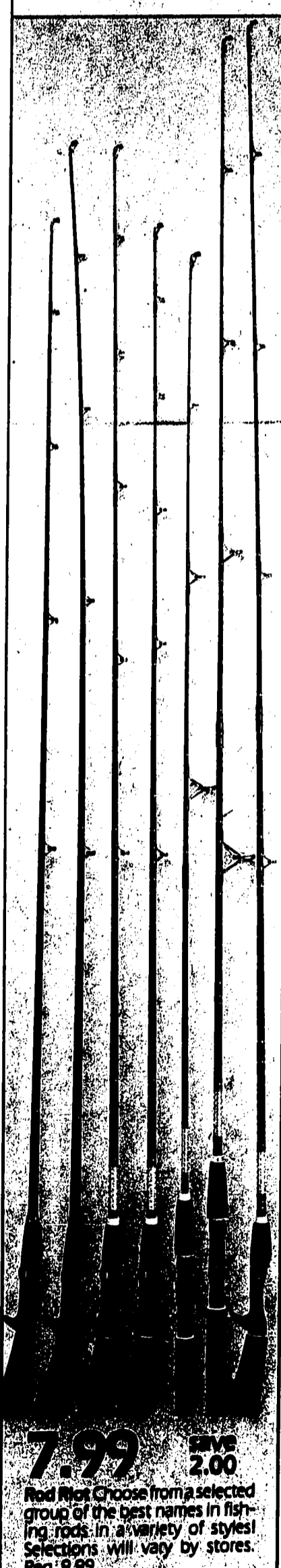



26.97 **save 3.00**

Daiwa Spinning Rod and Reel Combo Apollo Silver Series 100X freshwater reel with 3 bushings give smooth operation. 2-piece, 5'6" freshwater rod. 2-6 lb. Trilene test line, too. #100X/131. Reg. 29.97

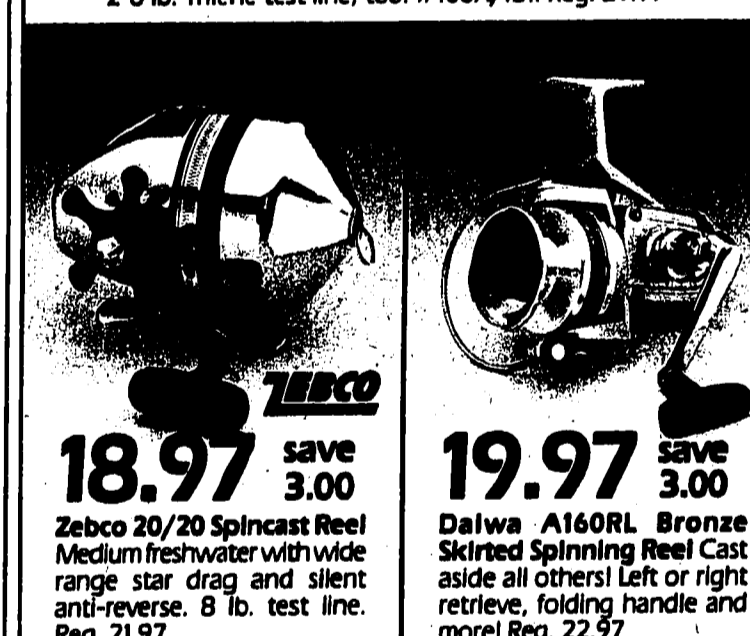

16.97 **save 3.00**

Fairfield Kwik Stix Graphite Rod The ultimate rod! A variety of styles and sizes in spinning or casting rods. All have single, fast fluorescent guides and pistol grips. #TG1400. Reg. 19.97



18.97 **save 3.00**

Zebco 20/20 Spincast Reel Medium freshwater with wide range star drag and silent anti-reverse. 8 lb. test line. Reg. 21.97

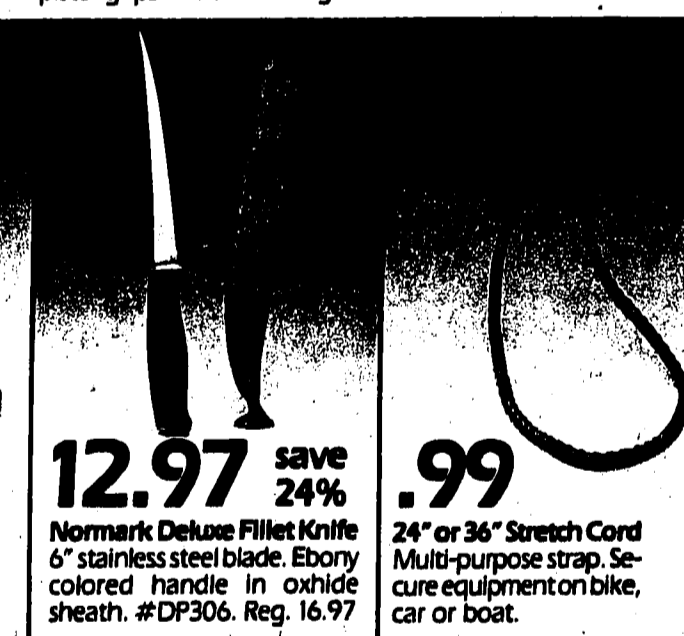

19.97 **save 3.00**

Daiwa A160RL Bronze Skirted Spinning Reel Cast aside all others! Left or right retrieve, folding handle and more! Reg. 22.97

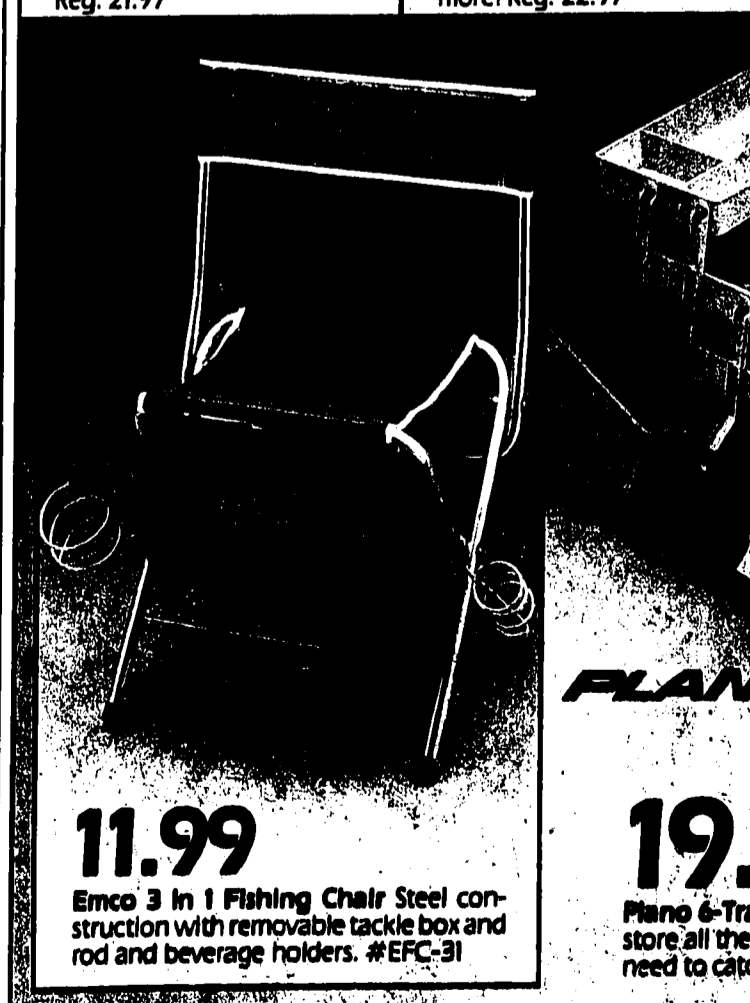

11.99

Emco 3 in 1 Fishing Chair Steel construction with removable tackle box and rod and beverage holders. #EPC-31

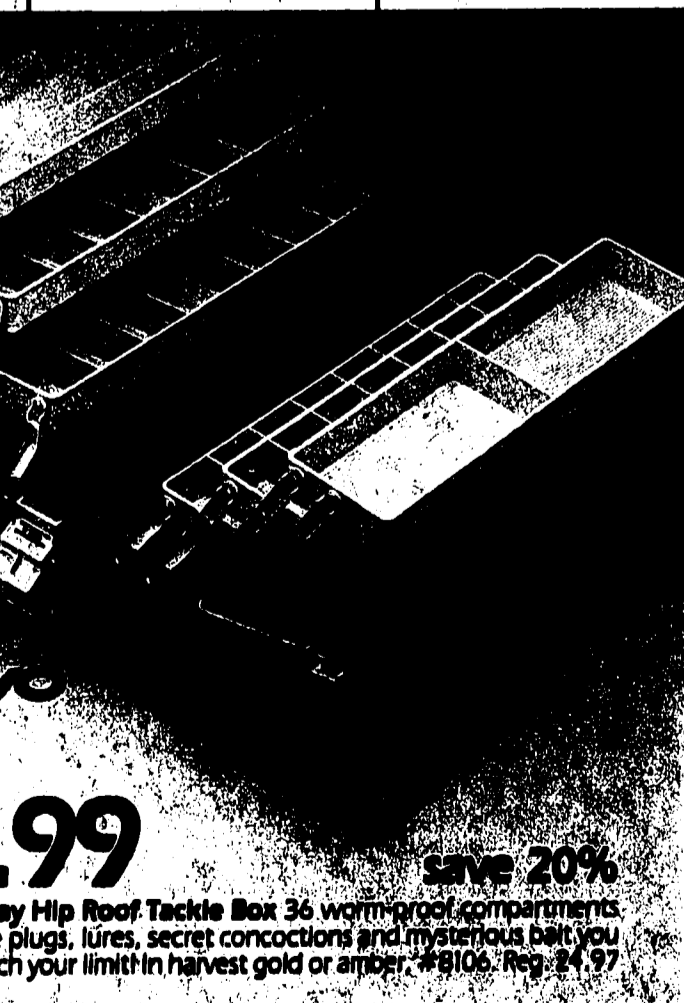

19.99 **save 20%**

Flano 6-Tray Hip Roof Tackle Box 36 worm-proof compartments store all the plugs, lures, secret concoctions and mysterious bait you need to catch your limit in harvest gold or amber. #8106. Reg. 24.97

TG&Y family centers

gifts to make Father's Day!

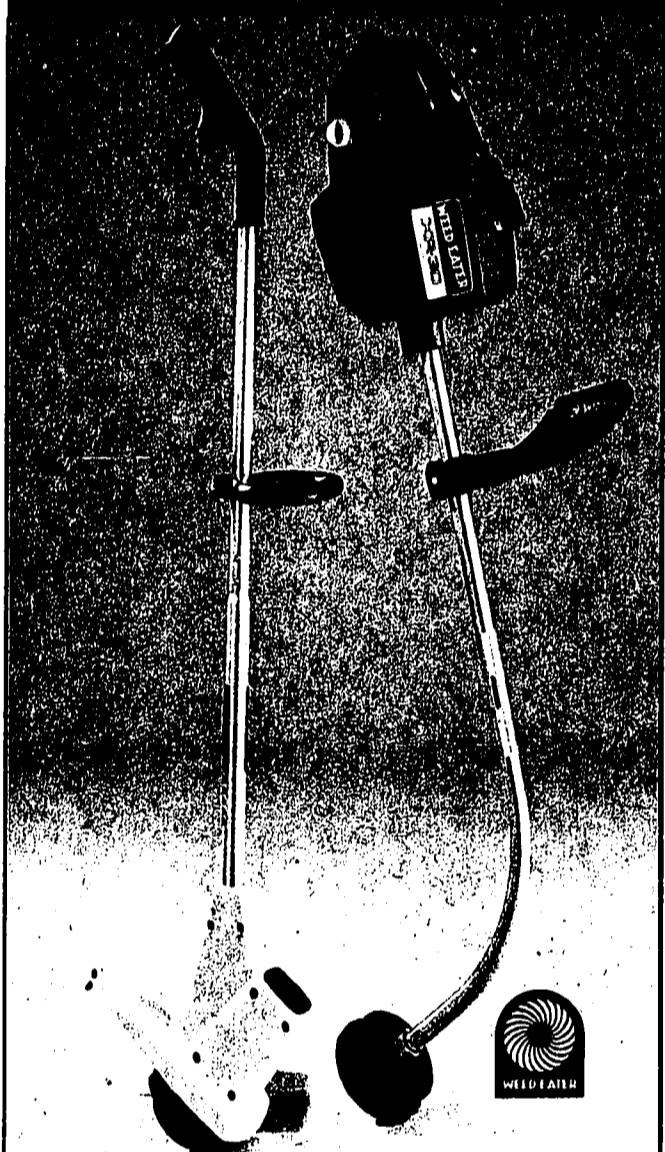

39.93 save 10.04

Weedster Model 807 Cuts a 14 inch path. For trimming and edging. Tap-N-Go semi-automatic line advance system includes 50' of line. 3 amp electric motor. #807. Reg. 49.97

99.96 save 40.01

Weedster Model XR30 Gas Trimmer Powered by a tough, 2-cycle, 26.2 cc engine. It features direct drive and Tap-N-Go line advance, which extends fresh line. Reg. 139.97



7.97 save 3.00 **8.97** save 4.00

Steel Chair Powder-coated steel frame with vinyl seat and backrest. 20" x 20" x 28" H. #1447241. Reg. 10.97



4.96

Flashlights Your choice: Floating Lantern with 6 volt battery. Large Floating Flashlight or Portable Indoor/Outdoor Lamp. #L-59WB, #XL600S or XT100.



16.96

Thermos Steel Vacuum Bottle One quart size vacuum bottle has a tough stainless steel liner. #2480C. Limit 2

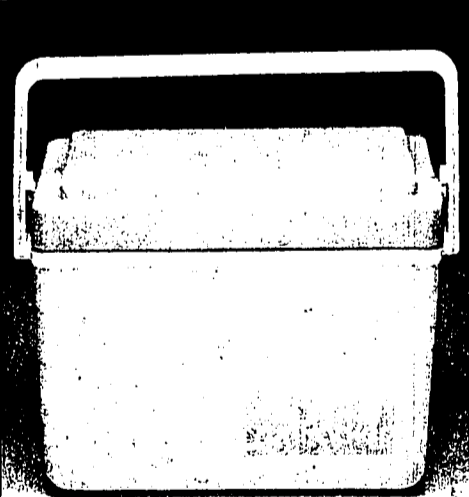

10.96

Thermos Sunpacker 11 Qt. Ice Chest Sturdy flip-over lid holds cups or cans. Urethane insulated. #7713/08. Reg. 15.99



2.37 save 20%

Old Spice After Shave The appreciated gift of Old Spice! 4 1/4 oz. Reg. 2.96



1.99 save 41%

Eveready Battery Heavy-duty, premium 6-volt carbon zinc battery. A low price! #1209. Reg. 3.37

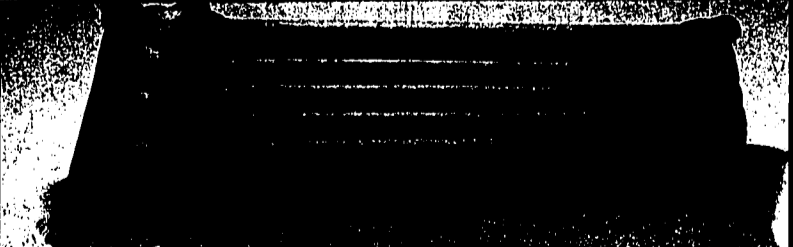

save 4.95 **12.93**

Fabric Covered Air Mattress Take comfort along with you wherever you go. 30 x 78". #9961. Reg. 17.88

TG&Y family centers

TG&Y's policy is to always have advertised merchandise in adequate supply in our stores. In the event the advertised merchandise is not available due to unforeseen reasons, TG&Y will provide a Rain Check, upon request, in order that the merchandise may be purchased at the sale price when it becomes available, or you may purchase similar quality merchandise at a similar price reduction. It is the policy of TG&Y to see that you are happy with your purchases. *It is TG&Y's policy to be priced competitively in the market. Regular Sale Prices may vary market by market, but the sale price will always be as advertised. *We will be happy to refund your money if you are not satisfied with your purchase. VISA® and MasterCard® accepted.

Father's Day Sale

Great savings. Great gifts. Like our Fox™ shirt.

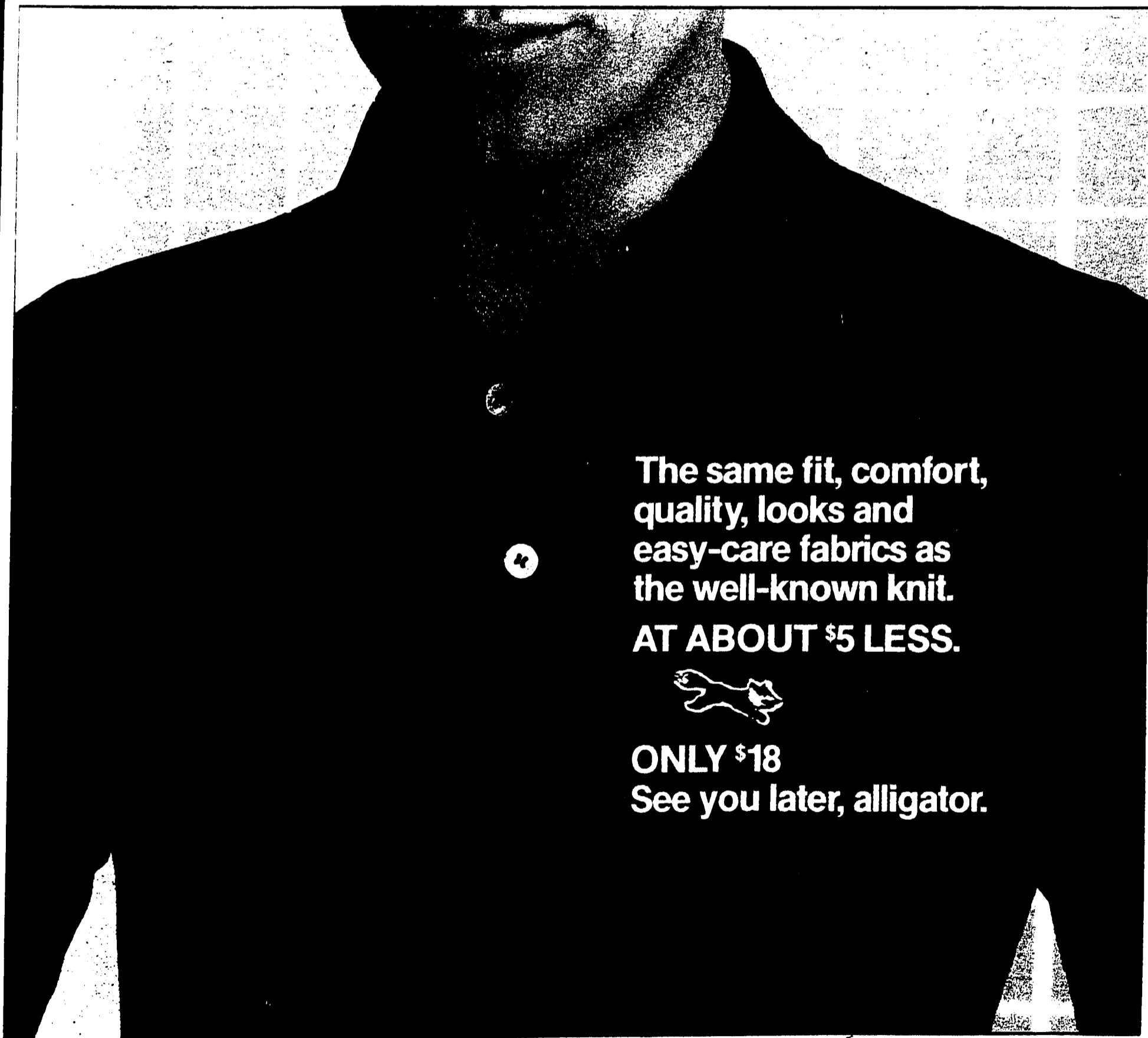

The same fit, comfort,
quality, looks and
easy-care fabrics as
the well-known knit.

AT ABOUT \$5 LESS.



ONLY \$18

See you later, alligator.



JCPenney

For Dad's sporty side. Par Four™ knits. Sale 9.99

A. Reg. \$12 to \$14. Suddenly, Dad's a sports spectacular! Par Four™ sportshirts teeing off in soft cotton/poly that looks great on the green or off. Solids or stripes in S, M, L, XL.

Sale 17.99

B. Reg. \$23. Par Four™ slacks in crisp, cool poly/cotton duck. Detailed with plenty of pockets, co-ordinating belt. Solids in waist sizes 32 to 42.

Sale 13.99

C. Reg. \$18. Par Four™ shorts. Choose poly/cotton oxford cloth or kettle cloth in solids. Cotton seersucker stripes or madras plaids. All belted for waist sizes 32 to 42.

On the cover:

Only \$18

The Fox™. A great-looking shirt that won't cost the shirt off his back. Dacron® polyester/combed cotton in solid colors, S, M, L, XL. Or, young men's tapered fit in 100% cotton with band sleeve, sizes S, M, L, XL. Dacron® polyester/combed cotton in stripes, only \$19

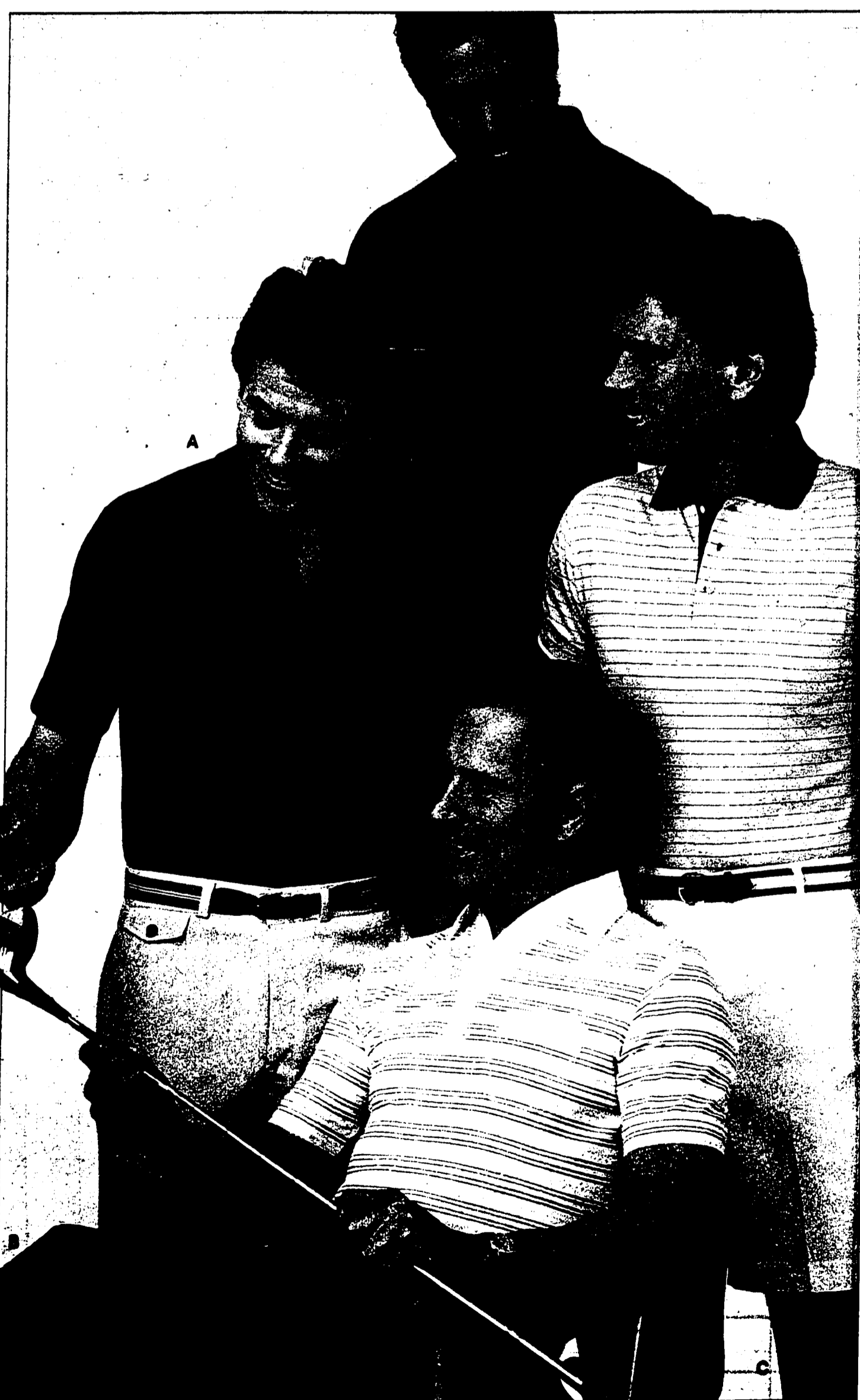

Top seeded pair-ups! Save \$5 on Newk's™ activewear.

Sale 14.99 and 15.99

Reg. \$20 and \$21. Newk's™ signature sportswear. Shirts of knit cotton and Kodol® polyester for hard play and easy-care. Choose from three top-form styles. Matching short of Kodol® polyester with handy side pockets. White with contrast waistband.

| | | |
|-----------------------|------|-------|
| | Reg. | Sale |
| A. Tops, S, M, L, XL. | \$20 | 14.99 |
| B. Short, 30 to 38 | \$21 | 15.99 |



Savings for Dad on our JCPenney sportswear.

Sale 7.99 to 12.99

Reg. \$10 to \$16. Winning looks that get Dad into the action with style. Cotton for comfort and polyester for easy-care.

| | | |
|-------------------------|------|-------|
| | Reg. | Sale |
| C. Coordinating top | \$14 | 10.99 |
| D. Swim trunk | \$13 | 9.99 |
| E. Knit tops in stripes | | |
| or two-tone | \$15 | 11.99 |
| F. Tennis short | \$14 | 9.99 |
| G. Ketch® knit top | \$16 | 12.99 |
| H. Corduroy short | \$12 | 8.99 |
| J. Easy Action® top | \$14 | 10.99 |
| K. Athletic short | \$10 | 7.99 |

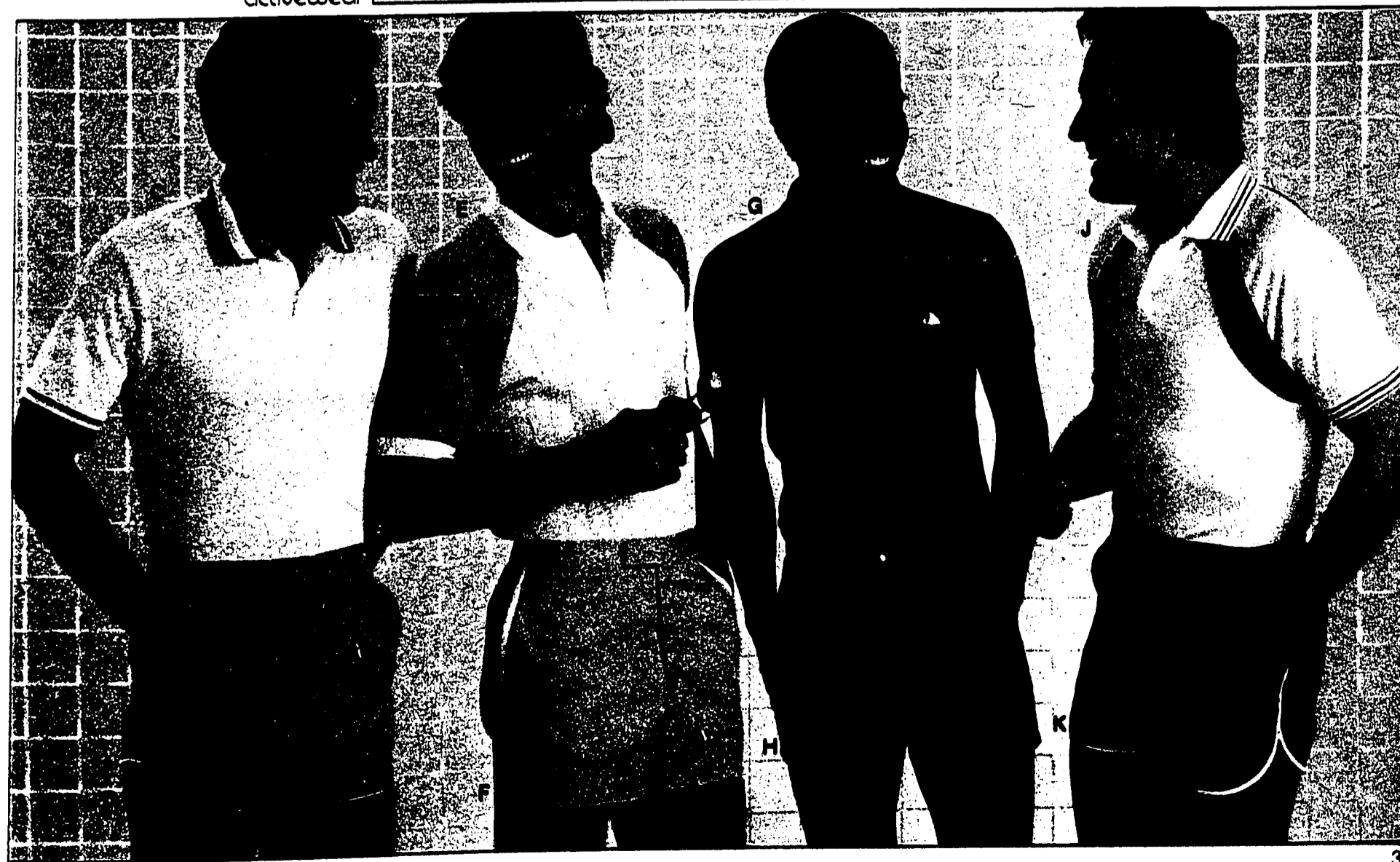

Pamper Dad and treat him to a little luxury for under \$10

Sale 7.99

A. Orig. \$12. Our Lustre-Silk™ shirt has the look and feel of the real thing, but it's easy-care woven polyester. Gentlemen's fit in white and fashion solid colors.

Sale 9.99

B. Reg. \$13 and \$14. Dad will love our Satin Touch™ shirt. Dacron® polyester/cotton with gentlemen's fit. Tone-on-tones or stripes.

Sale 7.99

C. Orig. \$13. Our High Cotton® poplin shirt is 55% cotton for comfort and 45% polyester for easy-care. Short sleeves in white and colors.

Sale 5.99

Orig. \$10. A great selection of ties, bold to basic. Satin stripes, fine lines, panels, more.



Save \$21 on the JCPenney Comfort Suit, Sale 59.99



A. Reg. \$81. The suit that lets him move in comfort. Tailored in a new stretch fabric of today's 100% Dacron® polyester from Klopman Textured Wovens. With plenty of give and take. Slack has flexible stretch waistband for more give, less bind. Coordinating jacket has flap pockets, center vent. Basic and fashion colors.
If purchased separately:
Blazer, Reg. \$60 Sale \$45
Slack, Reg. \$21 Sale 14.99

Dacron

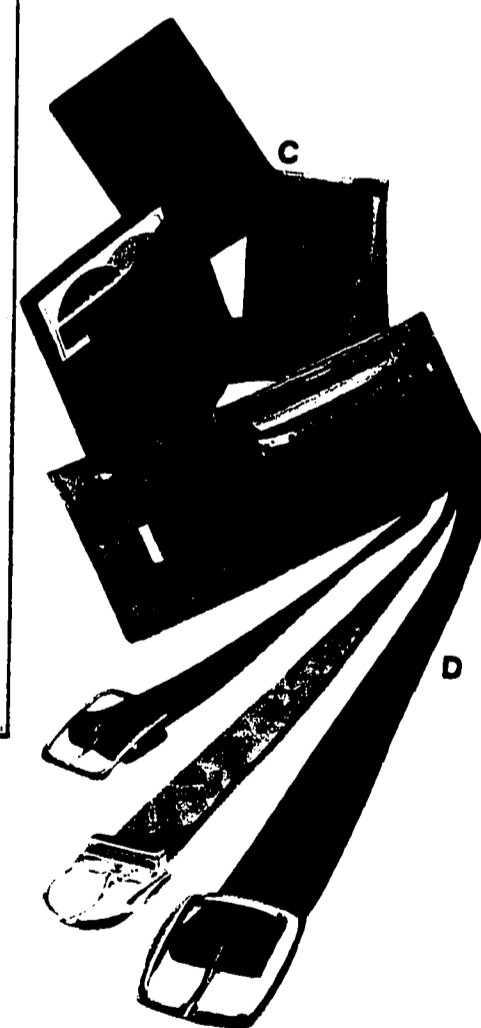

Save \$15 on these Comfort Plus® shoes for men. Sale 49.99

B. Reg. \$65. Comfort Plus® leathers, our finest dress shoes for men. So light and flexible you don't have to break them in. We think they're the most comfortable shoes ever. Choose wing tip tassel slip-on, dress oxford, or slip-on with metal trim.



50% off these giftable leathers. Sale \$6 to \$10

C. Orig. \$12 to \$20. Famous-name leather trifolds and billfolds. Practical, handsome styles with places for Dad's credit cards and cash.

Sale 4.25 to 7.50

D. Orig. 8.50 to \$15. Belts and more belts! Famous-name leathers including classic dress styles, reversibles, embossed jean belts. Some fabrics, too. Intermediate markdowns may have been taken. Does not include entire stock.

Mercury rising? Dad will love this cool shirt, Sale 7.99



A. Reg. \$10. Dad will breeze through the day in our Coolant™ shirt. An airy open weave of Fortrel® polyester in solid colors. Or, poly/nylon stripes. Scotch Release™ finish for easy laundering. S,M,L,XL.

Sale 14.99

B. Reg. \$21. The JCPenney Comfort Slack designed with a flexible waistband. For more give. Less bind. Tailored in a new stretch fabric of today's 100% Dacron® polyester from Klopman Textured Wovens. Fashion colors.



Tops that go easy on him. Easy on your wallet, too.

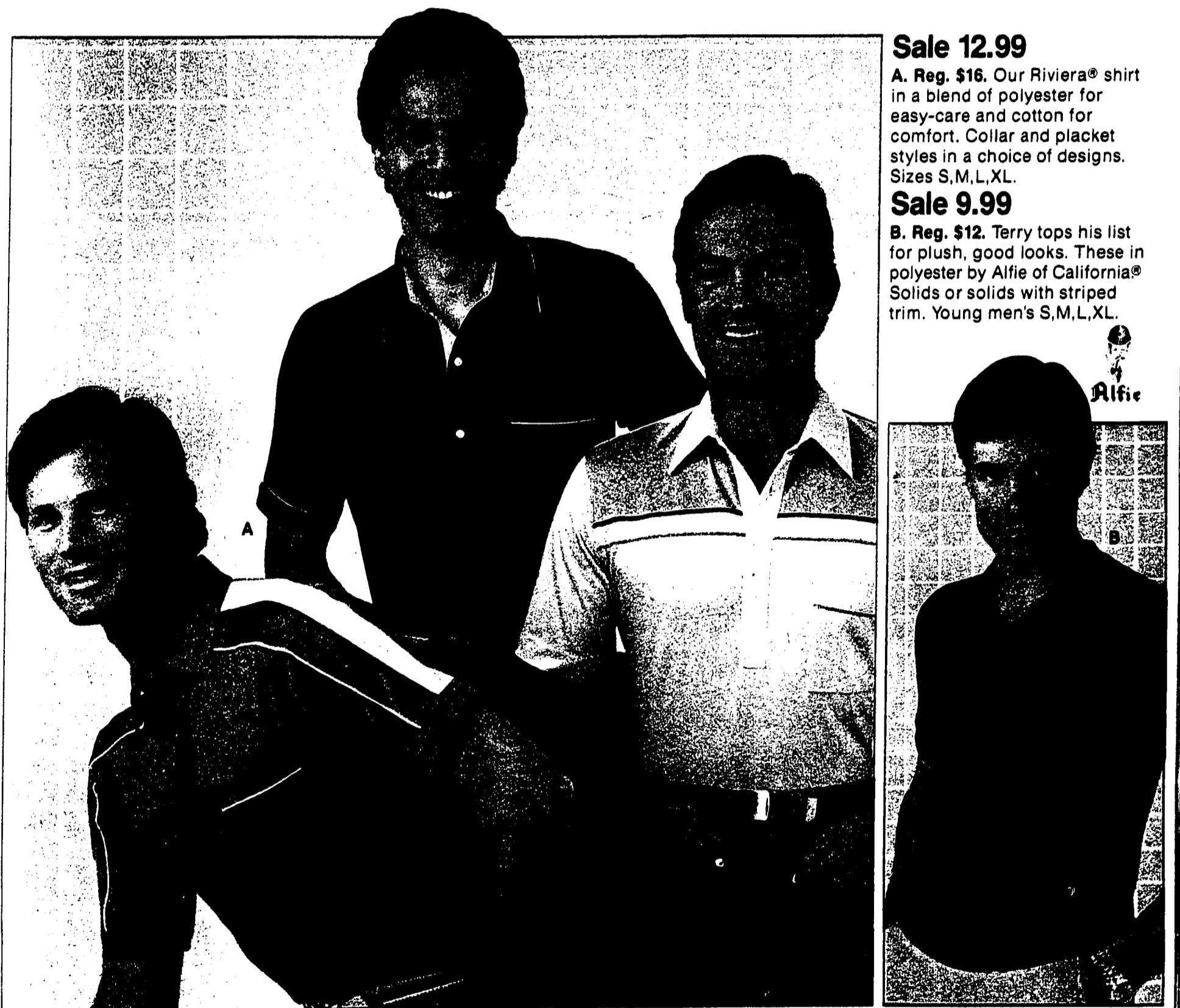

Sale 12.99

A. Reg. \$16. Our Riviera® shirt in a blend of polyester for easy-care and cotton for comfort. Collar and placket styles in a choice of designs. Sizes S,M,L,XL.

Sale 9.99

B. Reg. \$12. Terry tops his list for plush, good looks. These in polyester by Alfie of California® Solids or solids with striped trim. Young men's S,M,L,XL.



Sale 33.75

F. Reg. \$45. Deluxe 4" vinyl attache. With brass-plated hardware, expandable file inside.

Sale 48.75

G. Reg. \$65. Deluxe 4" vinyl attache with combination lock, expandable folder.

Sale 37.49

H. Reg. \$49.99. Bonded leather tri-pocket portfolio. With retractable handles, zip closure.

Sale 57.75

J. Reg. \$77. 3½" padded vinyl attache has wooden frame, 2 brass combination locks. Padded nylon interior.

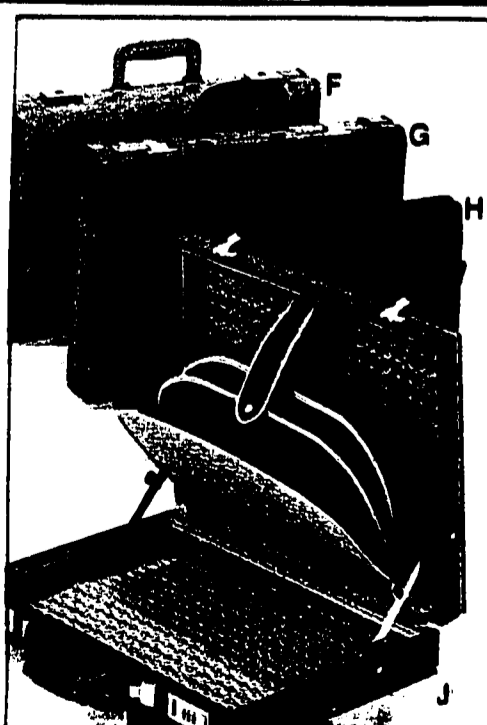

Sale 15.99 to 39.99

Carry on with our lightweight luggage. In great-looking nylon that really packs it in. Black, with triple stripe vinyl trim.

| | Reg. | Sale |
|-----------------|-------|-------|
| C. Garment bag | 49.99 | 39.99 |
| D. Boarding bag | 39.99 | 31.99 |
| E. Shoulder bag | 19.99 | 15.99 |



Sale 10.99

C. Reg. \$14. Dad will go for the rich, casual look of this terry pullover in lush polyester. Neat placket and collar styling. Fashion shades in S,M,L,XL.



Casual looks that take to texture. For under \$20.

Sale 13.99

A. Reg. \$18. As practical as it is good looking. Spun polyester knit shirt punched with piping trim. Sizes S,M,L,XL.

Sale 11.99

B. Reg. \$15. Logistix™ poly terry shirt. Open collar styling with chest pockets, piping trim. Sizes S,M,L,XL.

Sale 17.99

C. Reg. \$24. Contour® belted slack of poly/cotton poplin. Stretch terry belt. Waist sizes 28 to 38.

Sale 19.99

D. Reg. \$26. He'll take to tweed in Contour® belted slacks of Kodel® polyester/cotton/wool. Coordinating belt. Waist sizes 28 to 38.

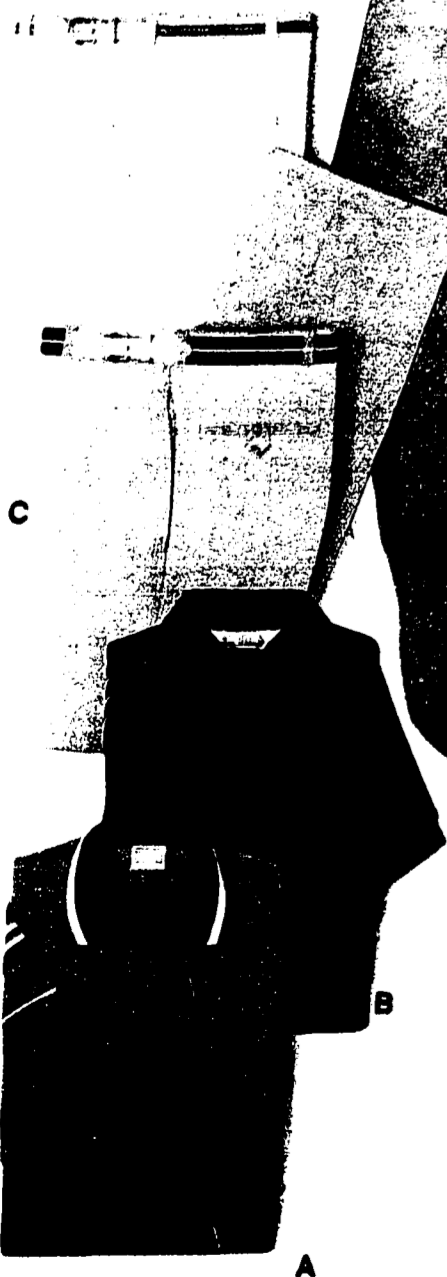

Only \$22. Only at JCPenney. Hunt Club™ for Dad.

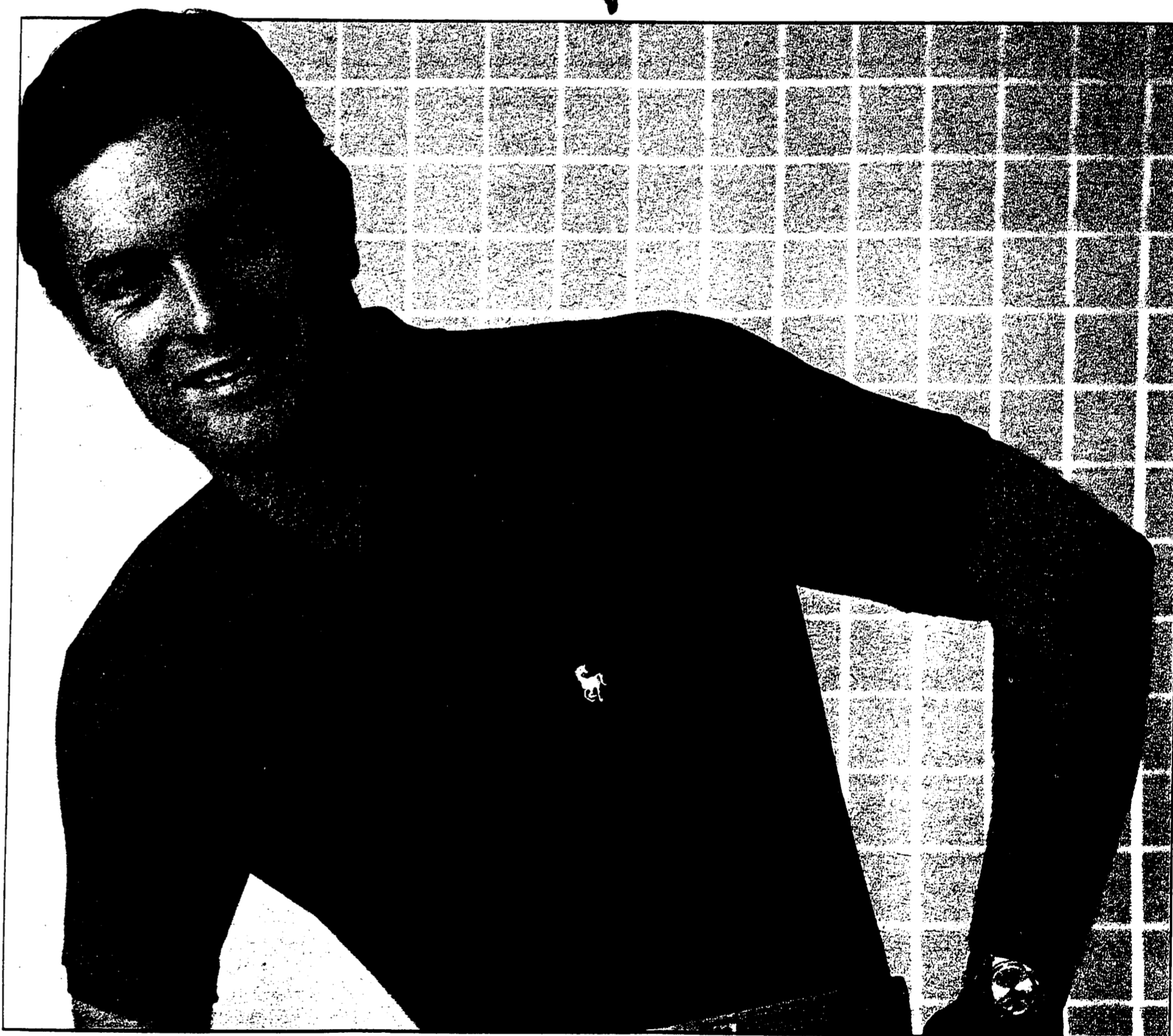

That all cotton knit shirt that's a horse of a different color.

Designer labels aside, he gets the kind of fashion, fit and fine all-cotton fabric that assures long wear and good looks wearing after wearing after washing. In a stampede of colors, from basics to brights. Men's sizes S,M,L,XL.



JCPenney

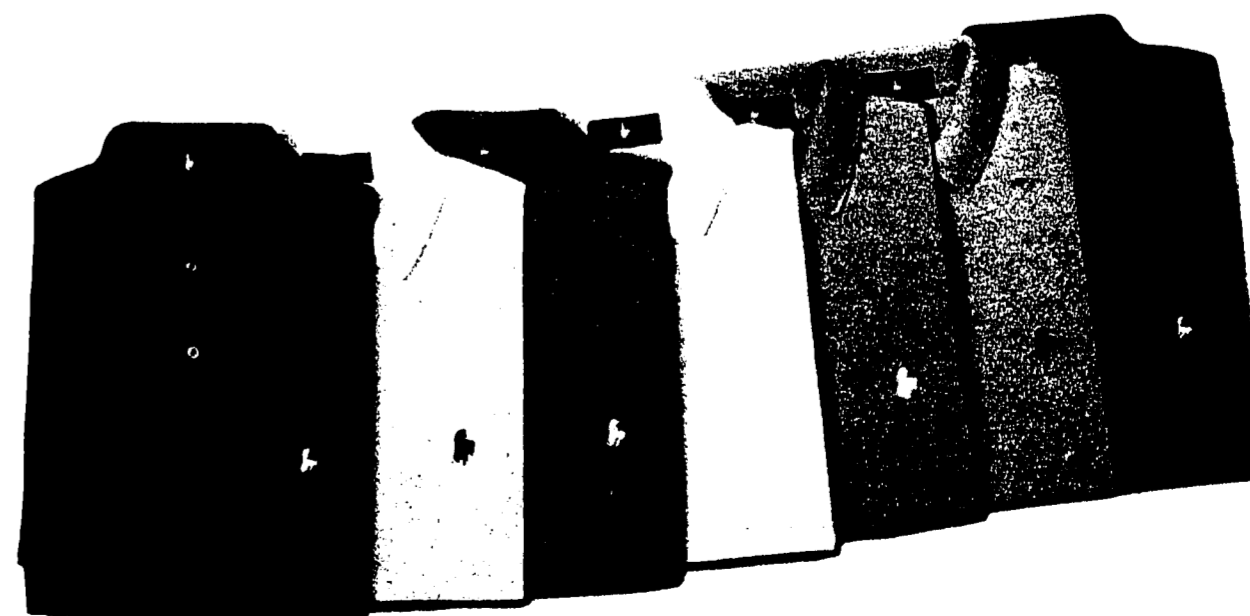

Our best-selling basics, now even better on sale.



Savings on all our T-shirts and briefs for Dad.

All men's white underwear is on sale just in time for Father's Day. Cut-for-comfort styles in polyester/combed cotton that keeps its shape washing after washing.

A. Crew neck t-shirt or briefs, Reg. 3 for 6.50 **Sale 3 for 5.49**

Save 20% on all robes, pajamas.

Lightweight robes and pajamas make great gifts for Dad. All at savings. Choose your favorites in cool, comfortable cotton/poly blends.

B. Robe, Reg. \$24 **Sale 19.20**
C. Print or solid pajamas, Reg. 8.50 **Sale 6.80**

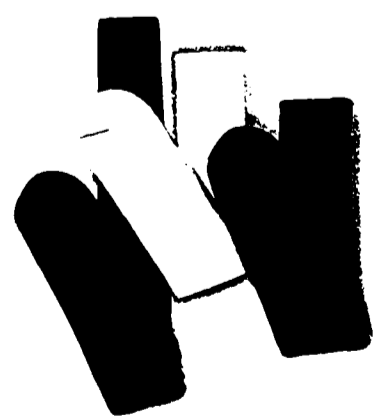

20% off all socks.

Sale 1.39 to 1.79 Reg. 1.75 to 2.25. Casual and dress socks including Bioguard® socks. Cotton/poly, cotton/poly/stretch nylon, acrylic/nylon and more. White and colors.



More than a pretty face. Functional, precise and 20% off.



Citizen watches.

Choose from our entire selection of classic and contemporary styles. Even analog quartz styles. Some with LCD readout, calendar and day/date features.

| | Reg. | Sale |
|-------------------------------|--------|--------|
| A. Silver-tone digital/alarm | 135.00 | 108.00 |
| B. Strap style | 75.00 | 60.00 |
| C. Gold-tone bracelet style | 115.00 | 92.00 |
| D. Silver-tone bracelet style | 55.00 | 44.00 |
| E. Gold-tone digital/alarm | 175.00 | 140.00 |
| F. Two-tone bracelet style | 99.50 | 79.60 |

●CITIZEN



Save on Pencron pocket watches.

Our entire group of Pencron pocket watches are sale priced. Perfect timing for Father's Day gift-giving!

| | Reg. | Sale |
|----------------------------|-------|-------|
| G. Quartz calendar style | 59.95 | 47.96 |
| H. Watch, knife, chain set | 44.95 | 35.96 |
| J. Railroad scene style | 29.95 | 23.96 |

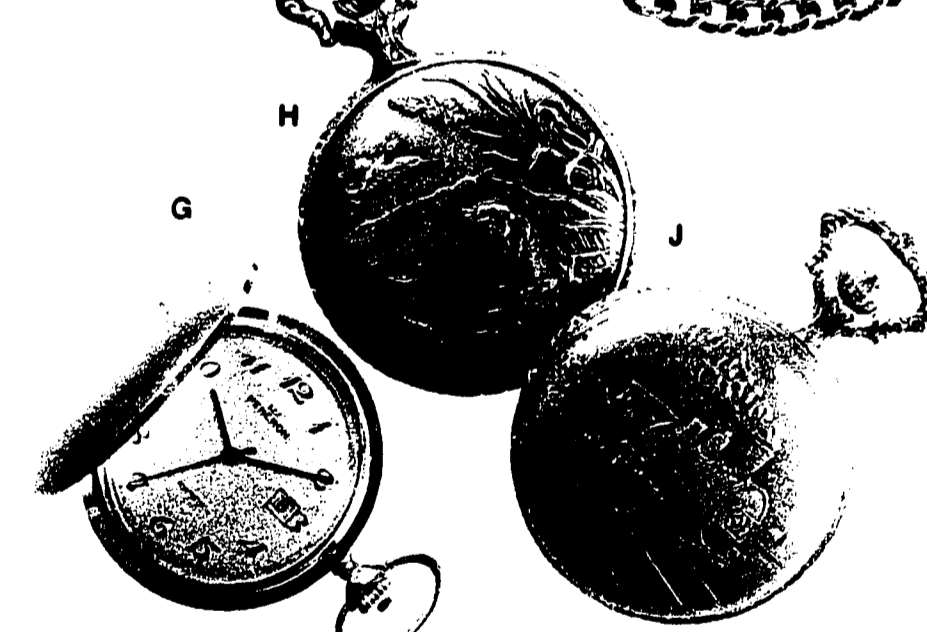

Save \$2 to \$4 on these JCPenney pro hairdryers.

Sale 9.99 to 14.99

Reg. 11.99 to 19.99. This year give Dad a good grooming gift that cares for him as much as you do. Choose from these great styles. Now at savings!

| | Reg. | Sale |
|------------------------|-------|-------|
| K. 1200 watt compact | 11.99 | 9.99 |
| L. 1400 watt pro dryer | 15.99 | 12.99 |
| M. 1200 watt mini-pro | 12.99 | 9.99 |
| N. 1500 watt pro dryer | 19.99 | 14.99 |

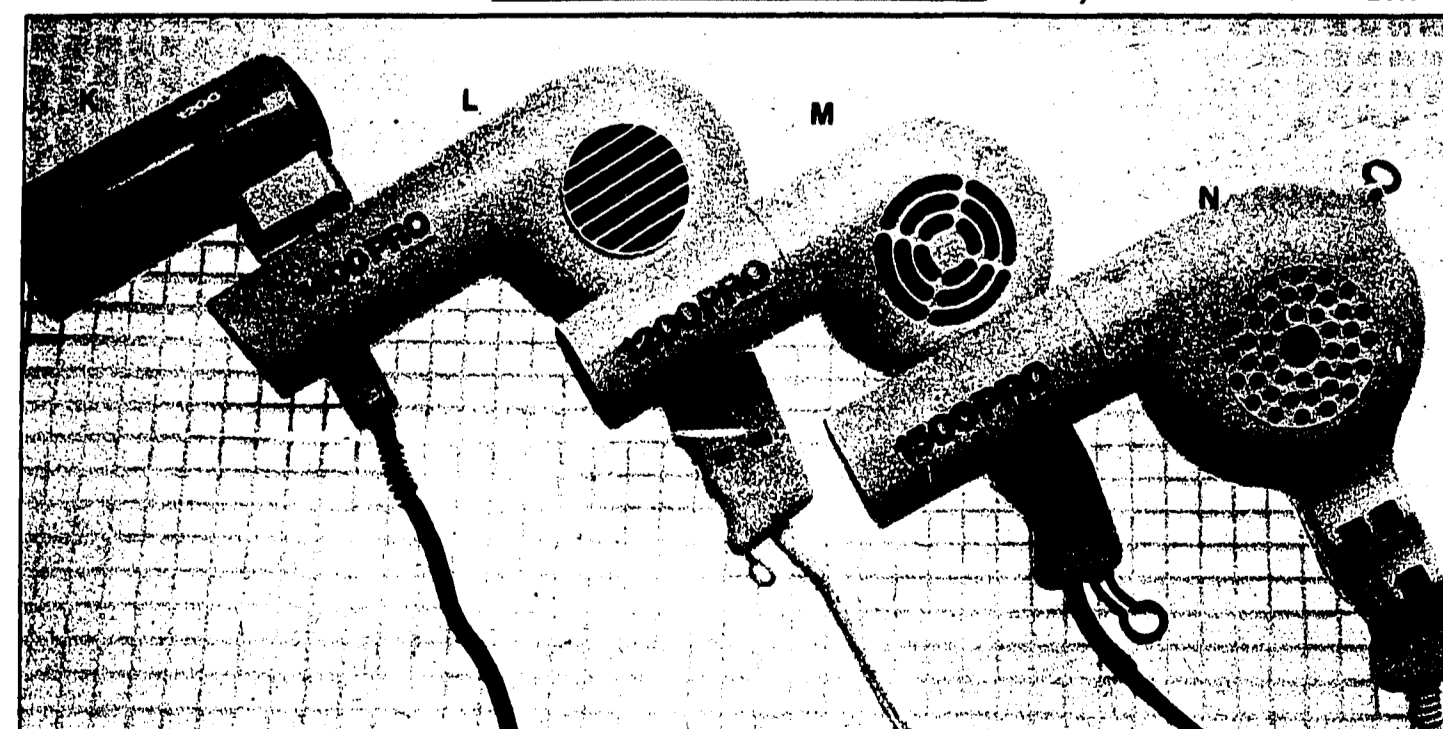

Pyramid In-Home Fitness System. Only at JCPenney.

Only 269.95

A. If purchased separately, would cost 324.95. Our In-Home Fitness System lets you exercise whenever you want. At home. Folded up it takes just 32"x30" of floor space. Features slant board with 2" foam padding, 5-position incline bench, chin bar, squat rack, leg curl, ballet bar and leg extension unit. Includes weight stack/high pulley system, low pulley assembly, lat bar, and arm curl bar. Folds for easy storage. Comes unassembled. Weights not included.

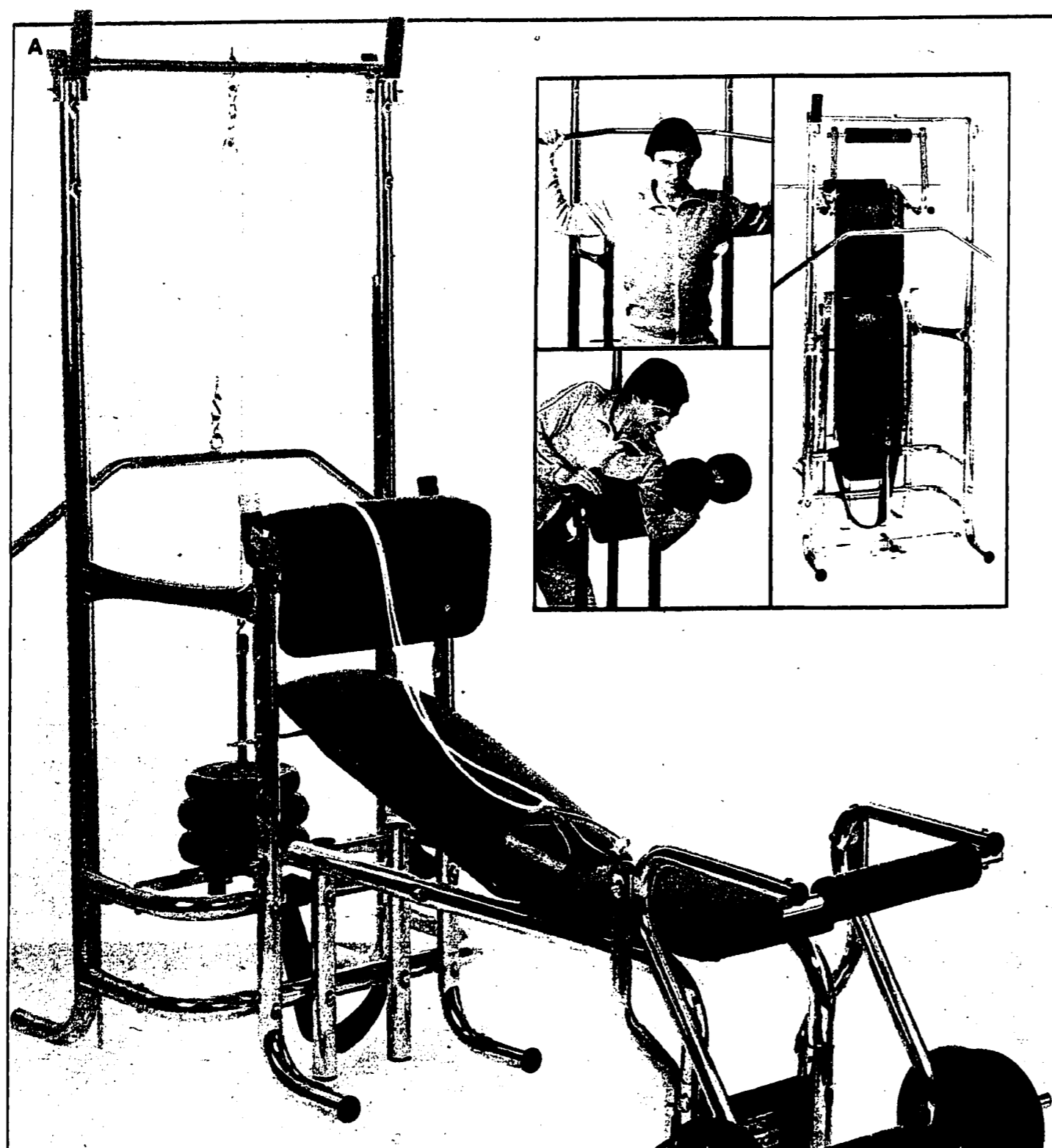

Sale 53.99 to 179.99

B. A terrific selection of golf clubs at money-saving prices!

| | Reg. | Sale |
|------------------------------------|--------|--------|
| Tom Watson golf set | 224.99 | 179.99 |
| Chi Chi Rodriguez set | 129.99 | 99.99 |
| Pro Registered starter set | 59.99 | 53.99 |
| Cordura® travel bag | 39.99 | 31.99 |
| Sunday-style golf bag | 27.99 | 22.99 |
| Pro-style bag | 46.99 | 37.99 |
| Starter bag | 21.99 | 17.99 |
| Set of 4 headcovers | 9.99 | 7.99 |
| 62" umbrella | 14.99 | 11.99 |
| Leather golf glove | 7.99 | 5.99 |
| Titleist® or Top Flite® golf balls | 14.96 | dz. |

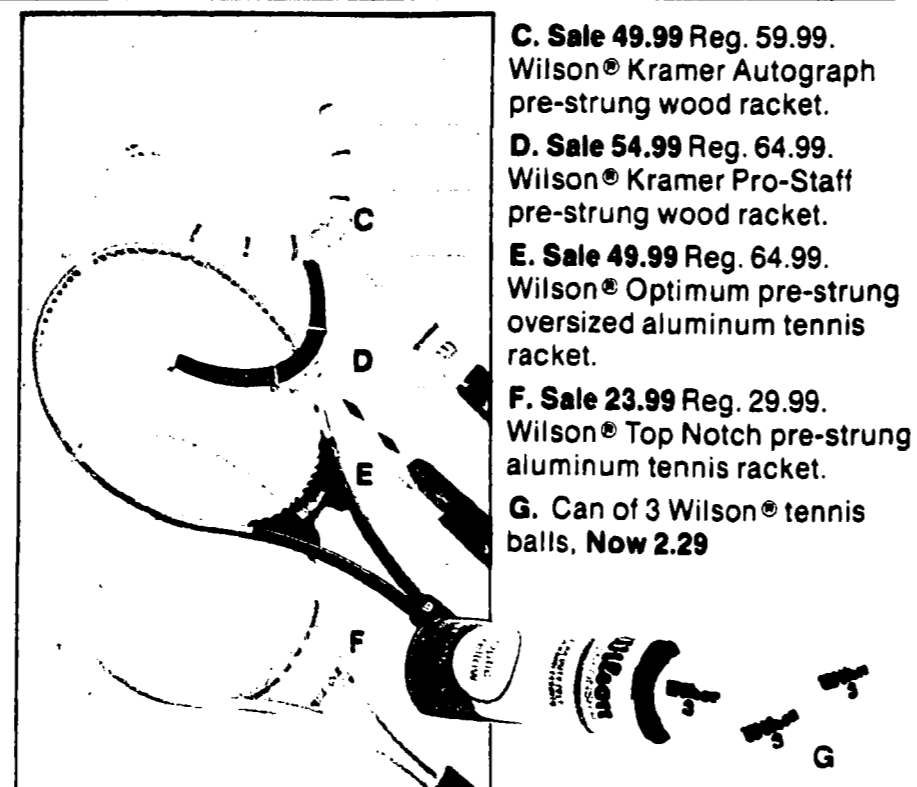

C. Sale 49.99 Reg. 59.99. Wilson® Kramer Autograph pre-strung wood racket.
 D. Sale 54.99 Reg. 64.99. Wilson® Kramer Pro-Staff pre-strung wood racket.
 E. Sale 49.99 Reg. 64.99. Wilson® Optimum pre-strung oversized aluminum tennis racket.
 F. Sale 23.99 Reg. 29.99. Wilson® Top Notch pre-strung aluminum tennis racket.
 G. Can of 3 Wilson® tennis balls. Now 2.29

Nike®, Spalding® and adidas® play best at savings. Sale 8.99 to 20.99

A. Sale \$10 Reg. \$14. Spalding® cotton/poly knit tennis shirt. Men's S,M,L,XL.
 B. Matching shorts. Reg. \$13 Sale \$10
 C. Sale \$19 Reg. \$22. adidas® tennis shirt of poly/cotton mesh. Men's S,M,L,XL.
 D. Matching polyester shorts. Reg. \$18 Sale \$15
 E. Sale \$17 Reg. \$20. adidas® classic polyester/cotton knit tennis shirt with logo. Men's S,M,L,XL.
 F. Sale \$15 Reg. \$18. Nike® all-cotton athletic shirt with logo. Men's S,M,L,XL.

Save \$3

G. Sale 19.99 Reg. 22.99. adidas® Low Court tennis or basketball shoe.
 H. Sale 20.99 Reg. 23.99. adidas® Jupiter training shoe.
 J. Sale 16.99 Reg. 19.99. Nike® Court Master basketball shoe.
 K. Sale 18.99 Reg. 21.99. Nike® Monterey II training shoe.



Sale 12.99

L. Reg. 15.99. adidas® water repellent nylon roll bag. With inside zipper compartment and outside pocket.

Sale 8.99

M. Reg. 10.99. Collapsible Nike® roll bag. Nylon with wrap-around handles, nylon zipper.

\$15 to \$30 off power tools. Save on hand tools, too.

A. Sale 49.99 Reg. 69.99. 7 $\frac{1}{4}$ " circular saw with rugged 2 HP, 10 amp motor. Has security switch, rip guide, and blade.

B. Sale 44.99 Reg. 59.99. Two-speed disc sander/polisher. 4 amp motor develops up to 1550 rpm. Includes rubber pad, sanding discs, polishing bonnet.

C. Sale 59.99 Reg. 89.99. $\frac{1}{2}$ " triple action drill. Operates as a rotary impact hammer, power chisel, or variable speed reversible drill.

D. Sale 59.99 Reg. 79.99. 3-in-1 table converts portable power tools to stationary use. For circular and sabre saws, routers.

E. Sale 9.99 Reg. 14.99. 19" metal tool box has handy lift-out tray.

F. Sale 17.99 Reg. 21.99. 43-pc. combination standard/metric socket set. $\frac{1}{4}$ ", $\frac{3}{8}$ " drive parts.

G. Sale 19.99 Reg. 24.99. 17-pc. standard $\frac{1}{2}$ " socket set.

H. Sale 9.99 Reg. 11.99. 13 pc. standard $\frac{3}{8}$ " socket set.

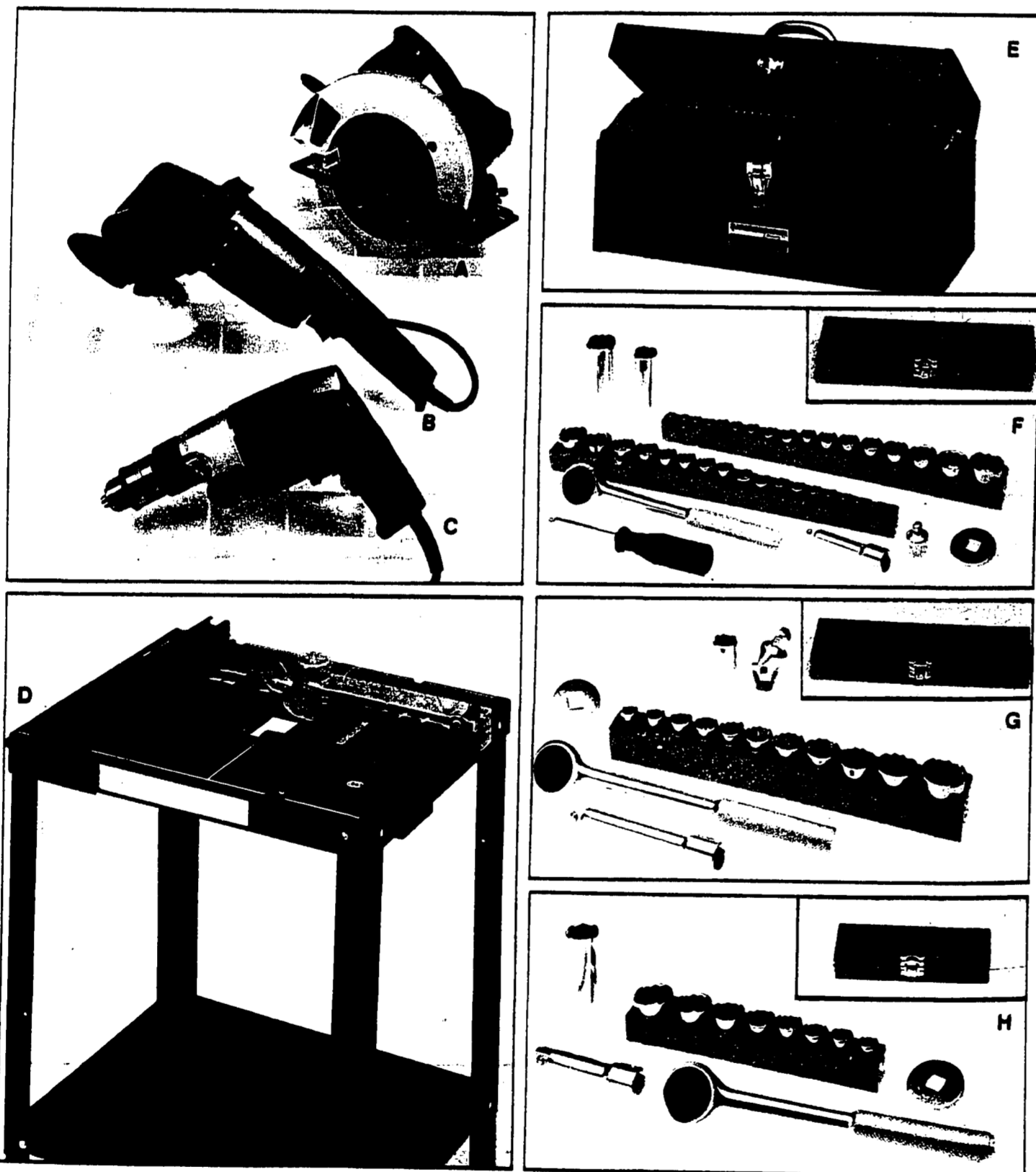

Sale 29.99

J. Reg. 39.99. Astro cot for use indoors or out. Has steel stand with striped polyester cover, treated for water-resistance. Unassembled.

Sale \$29

K. Reg. \$35. Director's chair. Folding classic that's right for patio or poolside. Natural color wood frame is finished for weather-resistance and lasting good looks.

Recovers for director's chair of sturdy 18-oz. cotton duck. Reg. 9.99 **Sale 7.99**
Textilene® vinyl/polyester recovers. Reg. 19.99 **Sale 14.99**

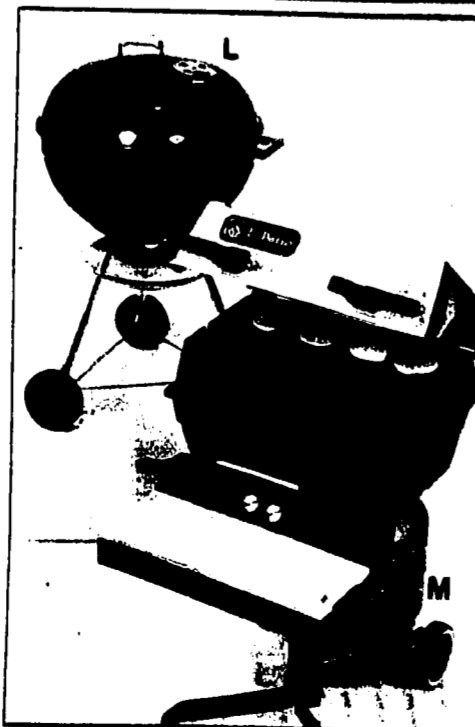

Sale 54.99

L. Reg. 64.99. JCPenney barbecue kettle by Weber®. Has 22" diam. grill, wood handles. Single lever bottom vent.

Sale 239.99

M. Reg. 299.99. Full-featured dual burner LP gas grill with 436 sq. in. cooking surface. Warming rack, automatic igniter, removable butcher block tray. Gas grill. Reg. 219.99. **Sale 189.99**

Save \$320 on this MCS Series® 35 watt stereo package.

With your choice of cassette deck or turntable. Only 499.80

A. If purchased separately, \$19.80. Package includes AM/FM digital frequency readout; two 3-way speakers with 10" woofer. Plus, your choice of Dolby® NR encoded soft touch cassette deck or direct drive semi-automatic turntable. #3236/8229/3554/6603
*Registered trademark of Dolby Laboratories Licensing Corporation.

35 watts RMS minimum per channel, 2 channels driven at 8 ohms, 20-20,000 Hz with not more than 0.04% total harmonic distortion.

Save \$30 to \$40

B. Sale 109.95 Reg. 149.95. AM/FM stereo cassette player/recorder with digital tape counter, soft touch. Balance tone controls. #3887

C. Sale 99.95 Reg. 129.95. SurroundSound™ portable stereo cassette player including FM stereo radio with headphones. #6006. Scotch® Dynarange 90-min. blank tape, Reg. 3.99 **Sale 2.99**



Sale 179.95

D. Reg. 219.95. 4-mode compact stereo system with cassette player/recorder, 8-track player, and AM/FM stereo radio. Receiver features pushbutton controls for power and program, plus AFC for good reception. Cassette deck has keyboard controls. 8-track player features program indicator lights. 3-speed automatic record changer has hinged dust cover and 45 rpm adapter. System includes two full-range speakers. #1769

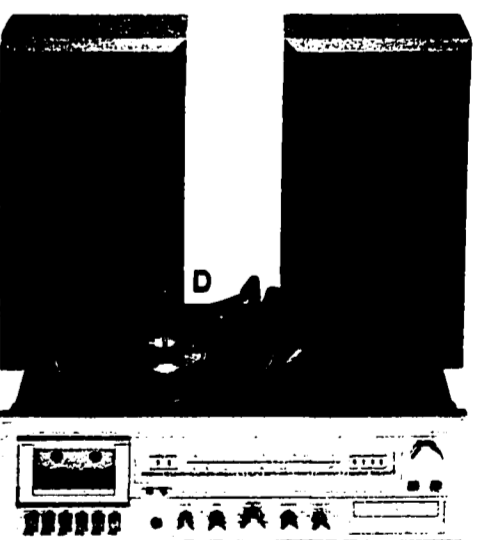

Sale \$299

E. Reg. \$349. 19" screen (meas. diag.) color TV features Chroma-Brite® black matrix picture tube. #2000

Sale 479.95

F. Reg. 549.95. 19" screen (meas. diag.) color TV with remote control, electronic scan tuning. #2054/57

Sale 149.95

G. Reg. 219.95. 7" screen (meas. diag.) b/w portable TV with AM/FM radio. Includes DC car cord, earphone. #1036

Sale 89.95

H. Reg. 119.95. 12" screen (meas. diag.) b/w TV. Easy click-stop channel selectors. DC car cord included. #1044
Simulated reception on all TV screens.



A fabulous fit for Dad. Jeans for Men, Sale 17.99



A. Reg. \$24. Action Master® boot cut jeans. Non-stop comfort for today's man on the move. Dark blue denim in cotton/stretch nylon. Medium blue denim or fashion colors in Celanese Fortrel® stretch polyester and cotton. 32 to 42.

B. Reg. \$23. McGregor® boot cut jeans in cotton/stretch poly sailcloth. Navy and colors.

IT'S FORTREL
That's all you need to know.



20% off all casuals.
Styled for comfort. Made to last. Like these leathers.

| | Reg. | Sale |
|-------------------------|------|-------|
| C. Boat-style | \$36 | 28.80 |
| D. Oxford or slip-on | \$30 | 24.00 |
| E. Oxfords | \$28 | 22.40 |

JCPenney

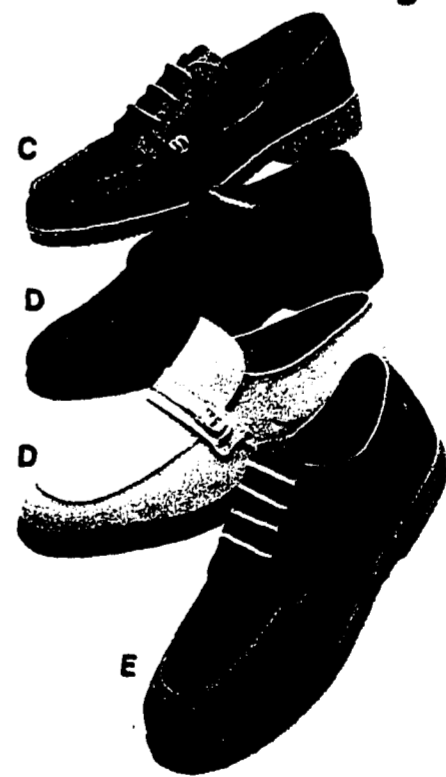

EVENT STARTS SUNDAY, JUNE 13, 1982
Shop JCPenney Sunday noon 'til 5 p.m.

Shop these JCPenney stores Monday-Saturday 10:00 a.m. til 9:00 p.m. ● Grosse Pointe Woods, 7 Mile & Mack, 884-3990, Catalog 885-3700 ● Lincoln Park, Fort & Emmons, 382-3396, Catalog 382-4453 ● Fairlane Town Center, Michigan Ave. & Hubbard, 593-3300, Catalog 593-3400 ● Tech Plaza, 12 Mile & Van Dyke, 573-4370, Catalog 573-4040 ● Twelve Oaks Mall, 12 Mile & Novi Rd., 348-3190, Catalog 348-3600 ● Northland, Greenfield Rd. & Hwy. 102, 557-6600, Catalog 557-5040 ● Eastland, 18000 E. Eight Mile Rd., 521-4900, Catalog 521-2330 ● Westland, Warren & Wayne Rd., 425-4260, Catalog 525-1700 ● Northwood, 13 Mile & Woodward, 288-6200, Catalog 288-5800 ● Southland, Eureka & Pardee Rd., 287-2020, Catalog 287-9000 ● Bloomfield, Miracle Mile, Telegraph & Sq. Lake Rd., 338-4515, Catalog Phone 858-2525 ● Lakeside, M-59 & Schoenherr, 247-1710, Catalog 247-1760 ● Oakland Mall, 14 Mile & I-75, 583-3400, Catalog 583-2006 ● Briarwood Mall, Ann Arbor, 500 Briarwood Circle, 769-7910, Catalog 769-6960

Luggage on page 8 and merchandise on pages 11-15 not available at JCPenney Northwood, Grosse Pointe Woods, Lincoln Park, Tech Plaza or Bloomfield. Personal care on page 11 available at JCPenney Northwood.

SALE PRICES EFFECTIVE THRU SATURDAY, JUNE 19, 1982

Advertising Supplement to the DETROIT FREE PRESS, Sunday, June 13, the MELLUS NEWSPAPERS, MACOMB DAILY/COMM. PRINTING PLANT and the OBSERVER & ECCENTRIC, Wednesday, June 16, 1982