

Confidence prompts expanded office park plans

By PHILIP JEROME

The North will rise again.

That, at any rate, is the apparent belief of the developers of the Orchard Hill Place Professional Office Park, who announced last week that they have purchased an additional 81 acres immediately north of their property on the northwest corner of Eight Mile and Haggerty Road.

The additional 81 acres extends north to Nine Mile along the Haggerty Road frontage.

"I guess you could call it confidence in Novi and confidence in Michigan,"

said Joseph Gerak, spokesman for the Orchard Hill Place Partnership.

"We're talking to a lot of people all the time and think there's enough interest and enough impetus to make it a worthwhile investment at this time."

"We wouldn't have done it otherwise."

Gerak indicated that the property was purchased in order to extend the Orchard Hill Place Office Park, which contains roughly 89 acres. Orchard Hill Place currently is the site of two Fortune 500 companies — Digital Equipment Corporation and Norris Industries, and a regional headquarters

for another Fortune 500 company, the Hewlett-Packard Company, is currently under construction.

In addition, Gerak has announced plans to construct a seven-story Hilton Hotel on the original 89-acre site.

The 81 additional acres purchased recently by the Orchard Hill Place Partnership is zoned R-3 (single family) and RM-1 (multiple family).

The Novi City Council and Planning Board have scheduled a joint public hearing for August 23 to consider a request to have the property rezoned to an OSC (office-service-commercial) designation. The original 89-acre site at

Eight Mile and Haggerty Road already has the OSC designation.

The hearing will be held in the Novi Public Library at 8 p.m.

Gerak acknowledged that the decision to purchase 81 additional acres was based on confidence in the Michigan economy and the success to date of the Orchard Hill Place Professional Office Park.

"We've had good response to our project so far and there's more coming," he said. Gerak said the property was not acquired for a specific use, but added that "we thought we ought to be prepared on the basis of the interest

that has been expressed.

"We sold an 11 acre parcel to Hewlett-Packard and we could not provide another 11 acre parcel on our original 89 acres even if the tenant came along," he said.

"There's enough interest in Michigan and enough interest in Orchard Hill Place to make us think it was the proper thing to do. We have some impetus (in attracting quality companies to Orchard Hill Place) right now and wanted to make sure we could handle additional demand."

Gerak also indicated that the timetable still calls for construction of

the Novi Hilton to begin this year. Site plans for the Hilton have not yet been submitted, but Gerak maintains there's still plenty of time to obtain site plan approval and break ground during the 1982 construction season.

The groundbreaking for Sheraton Oaks, for example, was held in November of 1980.

"We're still planning to break ground (on the Hilton) this year," he said. "Interest rates are beginning to drop and there's some indication that we may be able to obtain financing at a lower rate than initially anticipated."

Woman dies in traffic collision

A Novi woman was killed and her two grandchildren were injured when their car was struck broadside as it was traveling north on Novi Road near the Goat Farm Tavern July 27.

Barbara June Brown, 45, of 41812 Quince, died after being transported to Botsford Hospital.

Brown's grandchild, Sean Farrell, 4, was released from Botsford Hospital Thursday. The second passenger, Jamie Farrell, 6, is in fair condition at Children's Hospital in Detroit.

Hospital officials said fair condition is a favorable prognosis, meaning the child is conscious and in stable condition, but may be either uncomfortable or have minor complications.

Brown's car was struck by an automobile driven by Ralph J. Auten, Jr., of 23615 Ripple Creek, according to police. Auten was treated for injuries and released from Botsford Hospital the day of the accident.

Auten allegedly failed to yield the right of way as he turned onto Novi Road, police reported.

Before striking Brown's car, Auten drove his 1978 Oldsmobile more than 200 feet across the grass in front of the Goat Farm Tavern parking lot and the southbound lane of Novi Road.

The impact of the collision forced both automobiles off the road, police reported. There was extensive damage to the front of Auten's vehicle. Brown's 1981 Plymouth received extensive damage to the left front side.

Police said they could not determine the speed of either car or whether alcohol was involved in the incident. A routine blood test was conducted on the man, but results are not yet in.

City rewrites rules challenged in suit

By KATHY JENNINGS

With a court date with Bob Evans Farms, Inc. looming before them, Novi City Council members have amended the ordinance originally used to keep the restaurant from locating near the front of the West Oaks Shopping Center.

City Attorney David Fried introduced the ordinance changes, which he says "clears up any alleged ambiguity."

Fried noted the ordinance revisions were proposed after the city received a request for site plan approval from Bob Evans Restaurant.

After several meetings with representatives of the restaurant chain, council members voted 5-2 to reject the plans on the grounds they would hinder "harmonious land uses" in the area. The council also refused to reconsider the action after meeting repeatedly with representatives of the company and learning they wanted to maintain the red building which is considered the Bob Evans logo.

Bob Evans has filed suit in Oakland County Court asking that the ordinance used as the basis for rejecting the site plans be struck down. The matter is scheduled to be heard Friday, but has already been adjourned several times.

"During the course of the discussion with the applicant questions were raised by the developer, including whether the ordinance allowed the city control over architecture and design standards within a planned development," Fried said. "It was the developers' position that the ordinance was ambiguous and didn't give the council the authority to make decisions on those grounds."

"To resolve any alleged ambiguities in the original ordinance this ordinance spells out in more detail the criteria that was not detailed, but which was encompassed within the original ordinance," Fried explained.

The revised ordinance can have immediate effect on Bob Evans, Fried told the council.

Fried said after the meeting that he believes the Bob Evans plans can be reconsidered under the terms of the amended ordinance.

"One of the issues we've presented to the court is that they can return to the council under the new ordinance, because they have no vested right in the current ordinance. They have done nothing with their property," Fried said.

Continued on 7-A

Summer concerts generate crowds

By PHILIP JEROME

It's early on a Tuesday night at Twelve Oaks Mall and already the people are starting to come in, some of them carrying their own lawn chairs.

What's happening?
It's another concert in the free Tuesday night concert series sponsored by Twelve Oaks Mall in conjunction with the Detroit Federation of Musicians Trust Fund.

"They (Tuesday night concerts) have really been very successful," said Sheila Armstrong, sales promotion director for the regional shopping center.

"We get between 1,000 and 1,500 people each week just to hear the concerts. Some of them bring their own lawn chairs and a lot of them end up dancing before the concert is over."

"There are certain things I look forward to during the summer in Michigan, and one of them is music," she continued. "The concert series will definitely be continued next year, and I look forward to it continuing for a long,

long while.

"It's becoming a tradition at Twelve Oaks."

The concerts are presented by Tony Russo, a professional conductor, trombonist and violinist as well as a renowned music educator in the Dearborn Public Schools.

Russo has performed with the Detroit Concert Band and a wide variety of local dance bands. He also has performed at the Fisher Theater, Pine Knob, Meadowbrook and the Rooster Tail with the Johnny Trudell Band during the 1960s.

Armstrong says it's difficult to classify Russo's music because it changes every week. One week he may appear with his concert band and then return the following week with a jazz combo.

"The variety appeals to the people," she said. "There's a different program every week and I think people respond to the variety. It's all delightful, relaxing music."

Continued on 11-A



News photo by STEVE FECHT

Russ Button's plans to develop his property fell through, and 20 years later the now valuable land is still vacant

He owns Novi's 'best' hotel site

EDITOR'S NOTE: This is the fourth in a series of stories about Novi's developing areas and how those changes affect those living in the "path of progress."

By KATHY JENNINGS

If you ask Russ Button, he'll tell you he owns the best spot in Novi for a hotel.

"You can see it one mile either way on the expressway," says Button of his 8.5 acres on the east side of Novi Road.

But his plans for the property have been thwarted by both the Novi Schools and the City of Novi, according to Button.

He's owned a portion of the property since 1959 when he paid \$16,000 for two acres of land and a house.

Later he acquired two additional parcels, both 66 feet wide, one being 660-feet long and a second 1,320-feet long.

His plan was to develop it as a mobile home park, providing tax dollars to the city. But he always thought eventually he would sell the property to a hotel chain.

When he proposed the mobile home park to city officials, however, they turned him down.

"I had plans, engineering and state approval, but not the zoning of the City of Novi."

His rezoning request went down on a 2-3 vote of what was then the city council. He also lost a court case on the mat-



city in transition

As an adjunct to the regional center area, Novi officials have been paying increased attention of late to the "old downtown area" — in essence, the property surrounding the Grand River/Novi Road intersection.

Key to the city's planning effort is a proposed ring-road that would improve traffic circulation and open up numerous land-locked parcels — property with no road frontage — for development.

ter.
"They said it would depreciate the value of the property. That property hasn't changed since then. Twenty years later it's still the same. I've heard for 20 years that in another six

months this area will go."
The only thing that has changed is the value of the property.

Button says he once received a \$750,000 written offer for the land — and that was before the Novi Road bridge over I-96 was constructed.

Now he figures the land would be worth \$1 million, if anybody could get to it.

Button's property is land-locked. Once the property had frontage on Novi Road, but it was cut off when the state purchased easements for highway access.

The state offered to buy Button's 8.5 acres for \$39,500. Needless to say he rejected their offer.

"If all those little pieces could have been bought up under one ownership, the city could have forced the state to provide access. What happened was they just land-locked it and went home."

Without access, the residents on the property were moved out by the state and their homes have stood empty since that time, according to Button.

Button is not particularly encouraged by the recent talk of a ring-road around the Grand River/Novi Road intersection. Plans call for a road off the ring-road to connect to Button's property.

"There was a ring-road proposed 20 years ago and nothing ever happened with it. It will probably come about some day, but I'd hate to predict

when."
In fact Button says he doesn't expect the property to be developed in his lifetime. "I'll just sit on it and let my kids worry about it."

Button contends the school board holds the key to development of that area. He chastises the board for not selling Novi Elementary School.

"They had an offer five years ago, but someone said they needed to have a little more (money). Think of the money they could have made in interest by this time," Button says. "I don't think anything will open until the school board makes a move. But they'll wait until they get an offer that sounds like good politics to the rest of the housewives on the board."

(The school board received an offer for the school and the 11.3 acres it sits on, but school board members believed the terms of the sale were not favorable to the district. Superintendent Robert Pkwko reports: "If we received an offer that was fair and equitable we would be willing to sell it, but we're not going to just give it away.")

(Although the district has said in the past it would try to sell the property for the cost of replacing the elementary building, Pkwko said the current state of the construction business "would make that price difficult to determine." He added: "The population is such that

Continued on 7-A

Schools to open doors August 31

Students in the Novi School District will be heading back to the classroom earlier than usual this year — if all goes well.

Although the Novi School District is in the midst of negotiating new contracts with its five employees unions, a tentative class schedule has been announced.

Students will be reporting for class in just three weeks, with the first day of school set for Tuesday,

August 31, for youngsters in first through 12th grades. Kindergarten students will begin half-day classes Wednesday, September 1.

"Even though it is tentative, we thought it would be appropriate to get the information out to the parents," said Superintendent Robert Pkwko.

The starting dates hinge on the success of contract negotiations between the district and bargaining

units of its five employees unions. Pkwko expired June 31 for Novi's teachers, bus drivers, cafeteria workers, maintenance employees and clerical staff.

Pkwko said Tuesday he was optimistic about reaching settlements with the unions this summer.

"We feel we're making progress," he said. "We're optimistic."

Continued on 11-A

County property values climbing

Although the housing industry remains in a slump and sales of commercial, office and industrial properties are lagging, real estate values in Oakland County are continuing to rise.

Property values have climbed 13 percent since 1980 and 36 percent since 1979, according to the 1981 report published by the Oakland County Planning Division.

Troy led the county in non-residential developments. In 1981, some 255 permits were issued for non-residential construction. Industrial permits accounted for nearly 35 percent of the total. Commercial swept 35 percent and office 30 percent.

Novi topped the commercial permits list with 32, taking the lead from Troy which issued 29 permits in 1981.

Southfield issued 12 office building permits in 1981. In 1980, Farmington Hills topped the list with 15 but fell to second in 1981 with 10.

Overall, non-residential construction in Oakland County was down 30 percent in 1981 and 50 percent from 1979. Industrial permits fell 30 percent in 1981 and 60 percent since 1979.

Commercial building permits issued in 1981 declined nearly 15 percent from 1980 and 57 percent since 1979, according to the report.

Residential construction, as expected, was low during 1981. Only 1,887 permits were issued throughout the county last year—a 55 percent decline from 4,183 permits in 1980 and a 72 percent drop since 1978 when 10,279 permits were issued.

Approximately two-thirds of residential building permits issued in the county were from eight communities: Southfield (205), Avon Township (199), Birmingham (194), West Bloomfield (159), Novi (149), Bloomfield Township (126), Farmington Hills (109) and Troy (85).

From a broader perspective, Oakland County continues to be the largest provider of new single-family housing in the immediate six-county area, attracting more than 40 percent of the regional total.

Average selling price of all residential dwellings, both new and used in Oakland County, was \$72,880. That figure is based on a total of 9,036 units sold in 1981.

Bloomfield Township, West Bloomfield and Southfield have established some of the highest average selling prices in the county, according to the report.

Oakland's future developments appear to be around Novi and in Troy and more northern areas along I-75. While the number of platted subdivisions is down drastically, these areas appear to have the largest numbers of plots available for immediate development.

In 1981, only 44 plots were recorded, down 55 percent from the previous year's 101 plots and down 65 percent from the 124 plots recorded in 1978. As a result, 4,476 fewer lots were created from platted subdivisions than in 1979.

TUESDAY ONLY SPECIAL!
Top Loader Washer
50¢ ALL DAY Reg. 75¢
Novi Road Coin Laundry
1057 Novi Rd. • Northville
349-8120
7 A.M.—10 P.M. 7 Days

If you don't smoke...
Farmers can insure your home or apartment for less

AH WOK
Michigan's Nationally
Acclaimed Chinese Restaurant
"Come Taste Why"
• Specialize in Mandarin and Szechuan cooking
• Exotic Cocktails
• All major credit cards
• For fast carry out and Reservations call 349-9260
Special Businessmen's Lunch
Tues., Thru Sat. 11:00 to 3:00 p.m.
Lunch Special \$2.75 and up
All combination plates .. \$3.25
Includes soup, tea, main course, eggroll and fried rice.
41563 W. 10 Mile Rd. • Northville, Mich.
Corner of Meadowbrook • Closed Mondays

ABERDEEN'S
WEEKLY SPECIAL
Wed., Aug. 11-Tues., Aug. 17
Nacho Plate
• With Nacho Chips
• 1/2 LB. Hamburger
• 3 Cheddar
• Green Pepper, Lettuce, Tomatoes & Onions
\$1.99
• Homemade soups and sandwiches
• Pizza "made from scratch"
• Wed. is Ladies' Night—Drinks 2 for 1
• Happy Hour Mon.—Fri. 3-7 p.m.
• Weekend Entertainment
18730 Northville Road • Northville • 348-3490

Ask us for counseling prior to need
Many people today are interested in making financial arrangements prior to need. We offer complete information on pre-arrangements (including trust agreements), available now without cost or obligation. Feel free to ask us for assistance in your convenience. It may ease your family's concern tomorrow.

Floor Covering
Tile—Carpeting—Formica
100's of Samples
145 E. Cady • Northville • 349-4480

Bible Sale
Hard cover, revised standard, New Testament, Catholic edition.
Now **\$2.00**
Reg. \$3.50
Open til 7 p.m. Fridays

Heaven & Earth, Inc.
41539 Ten Mile Rd., Novi
348-3440
Leo & Sally Beauchamp

OFFICIAL NOTICE OF SALE
\$4,350,000.00
NORTHVILLE PUBLIC SCHOOLS
COUNTIES OF WAYNE,
OAKLAND AND WASHTENAW
STATE OF MICHIGAN
TAX ANTICIPATION NOTES
(GENERAL OBLIGATION—LIMITED TAX)

SEALED BIDS for the purchase of the above Tax Anticipation Notes will be received by the undersigned at the Office of the Superintendent, 501 West Main Street, Northville, Michigan 48167, until 11:30 o'clock, a.m., Eastern Daylight Time, on the 18th day of August, 1982, at which time and place the bids will be publicly opened and read. Award of the notes will be made by the Board at 7:30 o'clock, p.m., on August 18, 1982.

INTEREST RATE, PAYING AGENT AND PAYING AGENT FEES, AND DENOMINATION: The notes will be dated September 1, 1982, will mature April 1, 1983, and will bear interest at a rate not exceeding 18% per annum. Both principal and interest will be payable at a bank or trust company located in the State of Michigan to be designated by the original purchaser of the notes, which paying agent qualifies as such under the laws of the State of Michigan or of the Federal Government, with paying agent fees, if any, to be paid by the purchaser of the notes. Denomination of the notes to be at the option of the purchaser.

AWARD OF NOTES: for the purpose of awarding the notes, the interest cost of each bid will be computed on a 365-day year, 30-day month basis by determining, at the rate specified therein, the total dollar value of all interest on the notes from September 1, 1982, to their maturity and deducting therefrom any premium. The notes will be awarded to the bidder whose bid on the above computation produces the lowest dollar interest cost to the School District. No proposal for the purchase of less than all the notes or at a price less than their par value will be considered.

SECURITY: The loan is in anticipation of that portion of the OPERATING portion of the School Tax for the fiscal year July 1, 1982 to June 30, 1983, which is due and payable December 1, 1982. The Board of Education has voted and pledged as security for the tax note borrowing to levy taxes for school operating purposes, which taxes shall be due and payable December 1, 1982, in an amount NOT LESS than 200% of the amount of this tax note borrowing as approved by Municipal Finance Commission.

DELIVERY OF NOTES: The School District shall furnish notes ready for execution at its expense. Notes will be delivered without expense to the purchaser at a place located within the STATE OF MICHIGAN to be mutually agreed upon between the purchaser and the School District. The usual closing documents including a certificate that no litigation is pending affecting the issuance of the notes, will be delivered at the time of the delivery of the notes. Accrued interest to the date of delivery of the notes shall be paid by the purchaser at the time of delivery.

the Hearthside
Ethan Allen
Semi-annual
SALE
...now in progress...
Make the most of your space
with an Ethan Allen
Wall System, at great Sale Savings.



Sale \$1199.75
reg. \$1433.75 Save \$234.00
One of our most popular wall systems is rugged Antique Pine with matching easy-care Formica. Decorative laminate or wood tops. Perfect for bedroom, den or office-at-home.



Sale \$1249.75
reg. \$1489.75 Save \$239.00
Available in white or distressed yellow glazed finish with easy-care Formica. Decorative laminate tops. Here's a Custom Room Plan study and make-up center to delight any Junior Miss. The matching bundle bed offers space for an entire guest. All at Summer Sale savings now.



Sale \$1149.75
reg. \$1393.75 Save \$244.00
You'll love the drawer shelf, cabinet and work space in this elegant vanity. Includes sunny humming bird and matching easy-care Formica tops.

CITY OF NOVI
NOTICE OF PUBLIC HEARING

NOTICE IS HEREBY GIVEN that the Planning Board of the City of Novi will hold a public hearing to consider the rezoning of lands shown below. Said public hearing will be held at the Planning Board to bring the property in compliance with the Master Plan. The hearing will be held at 5 p.m., EDT (or as soon thereafter as same may be reached), Wednesday, September 1, 1982, at the Novi Public Library, 45245 W. Ten Mile Road.

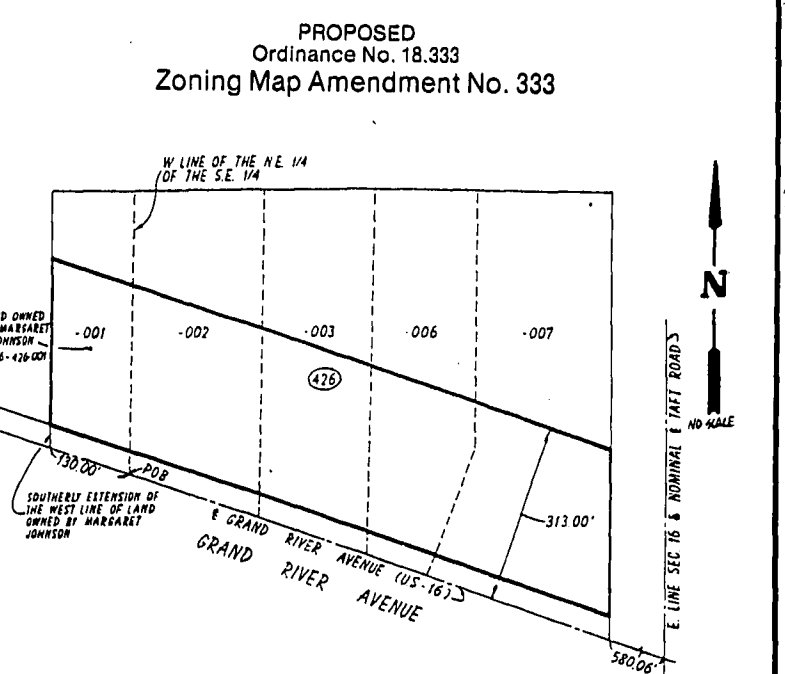

PROPOSED
Ordinance No. 18.333
Zoning Map Amendment No. 333

Beginning at the intersection of Grand River Avenue (Old US-16) and the west line of the northeast 1/4 of the southeast 1/4 of Section 16, thence Northwesterly along said centerline 130.00 ft., to the southerly extension of the west line of land owned by Margaret Johnson; thence Northwesterly along said west line and its southerly extension thereon, to the intersection with a line parallel with 313.00 ft. northerly of and at right angles to the centerline of Grand River Avenue (Old US-16); thence Northwesterly parallel with said centerline to a point 530.00 ft. west of the east line of Section 16; thence Southerly along a line parallel with and 580.00 ft. west of the east line of Section 16 to the centerline of Grand River Avenue (Old US-16); thence along said centerline to the point of beginning.

EXCEPTING THEREFROM: Any part of the above-described land taken, deeded or used as a street, road or highway.

FROM: B-3 GENERAL BUSINESS DISTRICT
TO: I-1 LIGHT INDUSTRIAL DISTRICT

Comments concerning the request will be heard at the public hearing or written comments will be received in the Office of the City Clerk, 45225 W. Ten Mile Road, Novi, Michigan 48050, until 5 p.m., Wednesday, September 1, 1982. All interested persons are urged to attend this hearing.

CITY OF NOVI PLANNING BOARD
Lee J. Wambui, Secretary
Patricia A. Loder, Deputy Clerk

Published August 11, 1982

Section **B**
GREEN SHEET
Sliger/Livingston East
Wednesday, August 11, 1982

Local firm glamorizes kitchens, even for Kelly & Co.

By KATHY LAVEY
Dan Mansfield and Gary Hancock at Mansfield Cabinets in Novi have kitchens for everybody—including television's "Kelly and Company."
Mansfield and Hancock, co-owners of the business established by Mansfield's father Clayton, got a frantic visit one July day from the property directors of the popular morning talk show, for which they needed a kitchen set for the next day's program.

Luckily, Mansfield said, he just happened to have a white and brown, modern-style "Omni" kitchen in his barn. They went and got it, made a few alterations and sent it to the studio. An oriental chef made noodles on it the next day over live television.
The property directors liked the Omni set so much they commissioned Mansfield Cabinets to build a permanent kitchen set for "Kelly and Company."

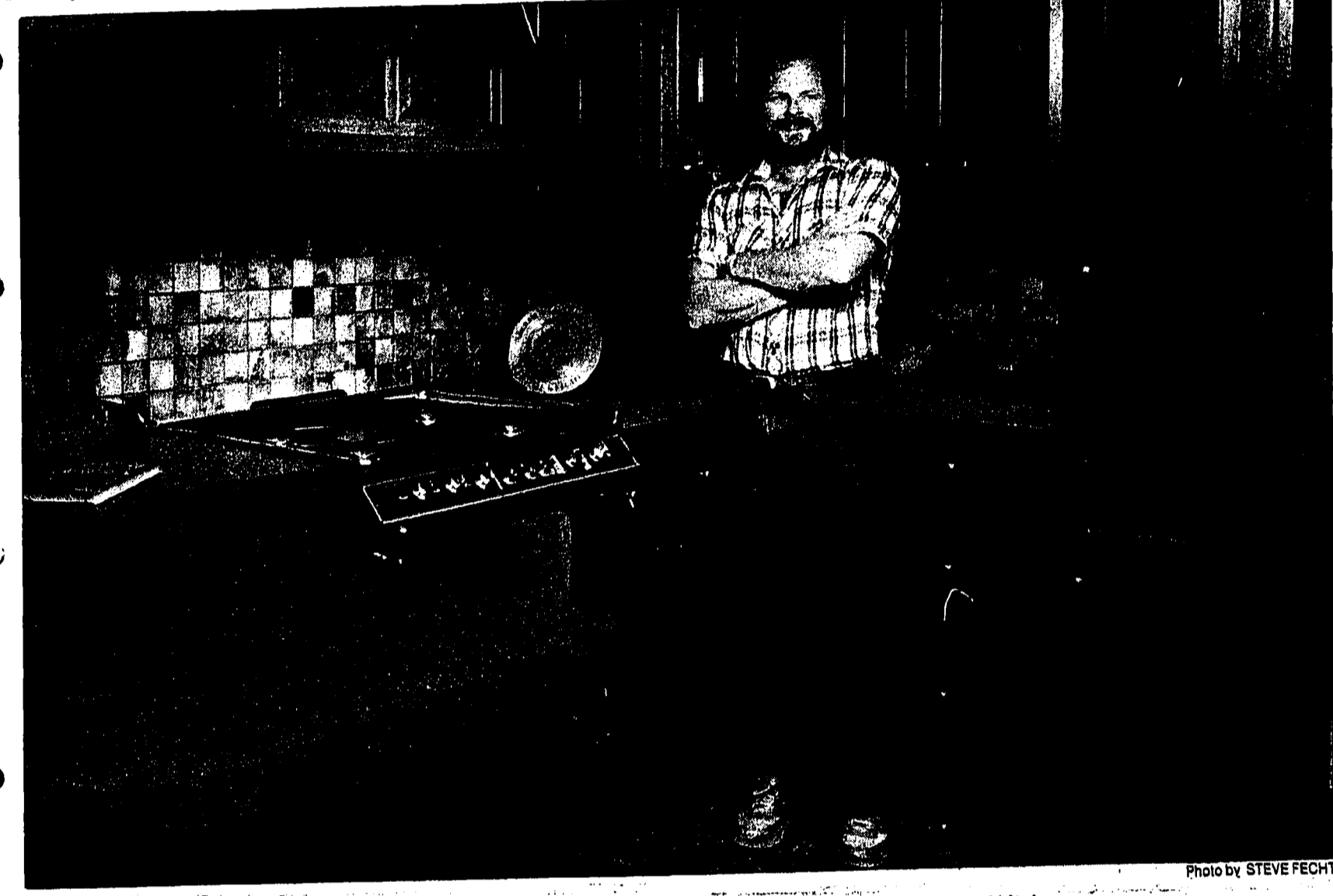

Gary Hancock proudly displays one of Mansfield Cabinet's custom-designed kitchens

They're currently working on a kitchen in a 10,000 square foot home that will cost about \$25,000 to complete, but Mansfield assures that the big spender is not their typical customer.
"We're more in tune to people with a minimum budget," he said. "We've cabinets for people with more money to spend. They also custom-design and build entire kitchens 'from little to large,'" says Hancock.
They're currently working on a kitchen in a 10,000 square foot home that will cost about \$25,000 to complete, but Mansfield assures that the big spender is not their typical customer.
"We're more in tune to people with a minimum budget," he said. "We've cabinets for people with more money to spend. They also custom-design and build entire kitchens 'from little to large,'" says Hancock.

Getting the design off paper and into the kitchen is an involved process, and last minute revisions are often made to better fit the space available or keep the project under budget.
Special finishing touches personalize many kitchens. An extra spice drawer was added for one couple who cooks often; a special rack was installed for a woman who complained of having to search the fold-out shelves in her Rutt cabinets for bottles of vitamins.
The same care that goes into design is carried out through construction and installation of the cabinets. Top formica is installed last to make a better counter edge; backsplashes are counted to the walls of the kitchen for a perfect fit; workmen stay on the job until the customer is happy.

In fact, Mansfield and Hancock say they often get to know customers well before they see them so much and work with them so closely in designing their kitchens. "Most customers become our friends," said Mansfield. "Five years later, sometimes, we go back and fix things for them."
Having customers with kitchens they like, Mansfield admits, is great for business. Every kitchen built is an advertisement for Mansfield Cabinets, and much of their business comes from word-of-mouth referrals made by happy customers to their friends.
The kitchens that pull customers' friends into Mansfield Cabinets force Mansfield and Hancock to keep standards high to make sure those people stay happy. "We have to give them a real nice job," Mansfield said. "Just because they like us doesn't mean we can go out to their kitchen and slough off."

Case August Clearance Sale At Old Prices
16 H.P. Tractor with mower
Reg. \$4645.00 **Sale \$3290**
10 H.P. Tractor with mower
Reg. \$2995.00 **Sale \$1995**
Loader
Reg. \$5500.00 **Sale \$4250**
50% OFF
NEW HUDSON POWER
437-1444



• 10 H.P. Cast Iron Kohler Engine
• 4 Speed Trans. Cast Iron Rear Axle
• Lights
• 12 Volt Electric Start
• Double Channel Frame
• Weighs 840 Lbs.

• Twin Cylinder Onan Engine
• Hydraulic Lift With Down Pressure
• High Clearance
• 8 x 16 Rear Tires
• Electric Start & Lights

• Onan Cast Iron Engine, 16.5 hp, 2 Cylinder
• Loader Lift Capacity 650 Pounds
• Breakout Capacity 1100 Pounds
• Digging Depth 21 inches
• Wheelbase 4 Feet
• Overall Width 44 inches
• Mower and Tiller Available

• 4 H.P. Cast Iron Cylinder
• Stellite Exhaust Valve & Seat
• Oil Pressure Pump
• Stay Power Mechanical Governor
• C.D. Ignition
• 2 QT Gas Tank
• All Steel Deck and Handles
• Extra Large Steel Wheels

Hours: Mon.-Fri. 9-6
Sat. 9-4

53535 Grand River at Haas
2 miles West of Wilcox Road

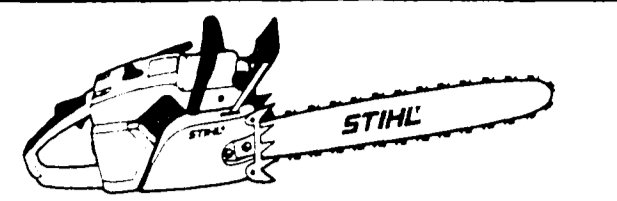

IT'S ALL MUSCLE. Model 01S1L-14" Bar & Chain Sale. Model 041AV Farm Boss 20" Sale. STIHL. The World's Largest Selling Chain Saw.

Wheel Horse Clearance Sale

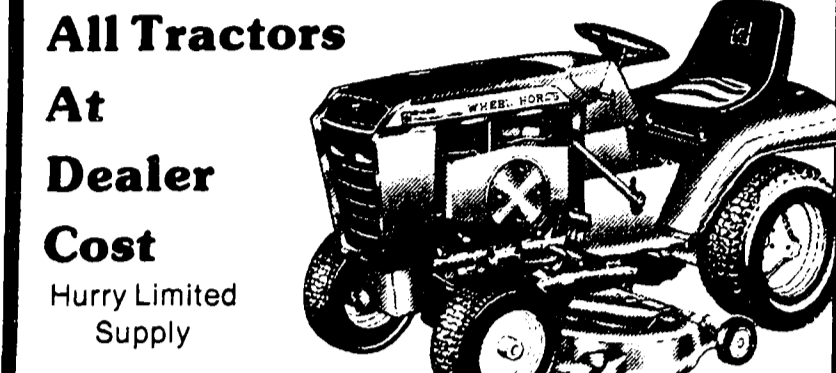

All Tractors At Dealer Cost. Hurry Limited Supply. Highland Outdoor Center. 1135 So. Milford Rd., Highland. (313) 887-3434

REDUCE POUNDS WITHOUT HUNGER! EAT REGULAR HEALTHY FOODS

You could lose between 3 to 7 pounds a week without drugs, pre-packaged foods or exercise!

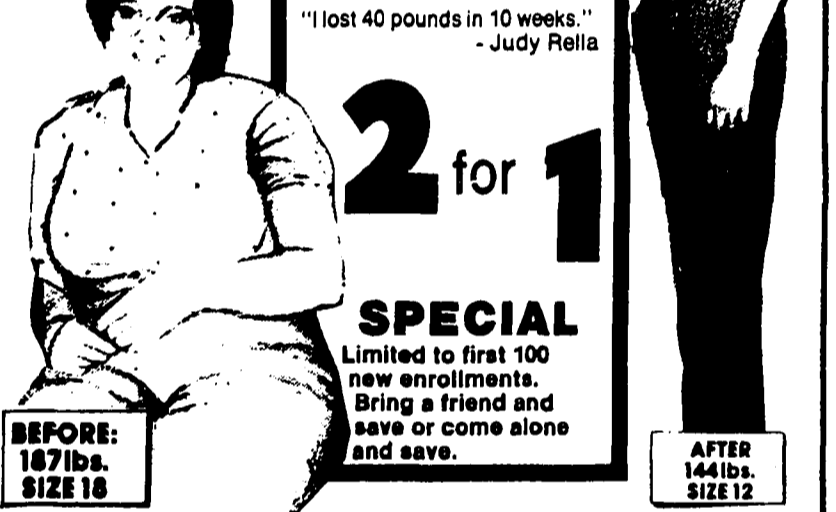

2 for 1 SPECIAL. Limited to first 100 new enrollments. BRIGHTON...227-7428

Every Night a "Special" at PAIZANO'S

Mon. Open Faced BBQ Beef Sandwich, Hot German Potato Salad, Salad Bar, 25c Draft Beer (with meal) \$3.95. Wed. ALL U CAN EAT Spaghetti, Salad, Italian Bread, \$2.75. Fri. & Sat. SURF & TURF Shrimp & Prime Rib Complete Dinner \$10.95

Business Briefs

BOB STONE, who recently joined the firm of Bruce Roy Realty, Inc., in Northville, made real estate sales in excess of \$500,000 during July. Stone was owner-broker of Realty Center, Inc., in Walled Lake. He sold the firm earlier this year and moved back to the Northville market.

DeMattia Company constructs \$2.5 million Coca-Cola center

Robert A. DeMattia of Northville, president of the R.A. DeMattia Company, has announced this firm will begin construction of a \$2.5 million distribution center for Coca-Cola in Van Buren Township.

Three familiar corporate names are putting their money where their mouths are in expressing confidence in Michigan's economic future, said DeMattia. Alexander Hamilton Life Insurance Company, which is headquartered in Farmington Hills, said, "This significant investment by Alexander Hamilton Life Insurance Company helps continue jobs in Michigan and will help a respected company like Coca-Cola relocate into larger facilities."



DeMattia said he was impressed and appreciative of the probusiness attitude of the Van Buren Township elected officials. "We've been putting this package together for months," said DeMattia, "and the township officials have been aggressively cooperative in trying to win this distribution facility for Van Buren Township."

Van Buren Township Supervisor Patricia Cullin looks on as Richard Headlee, president of Alexander Hamilton Life Insurance Company, signs purchase papers for \$2.5 million worth of Economic Development Corporation bonds permitting construction of a Coca-Cola distribution center.

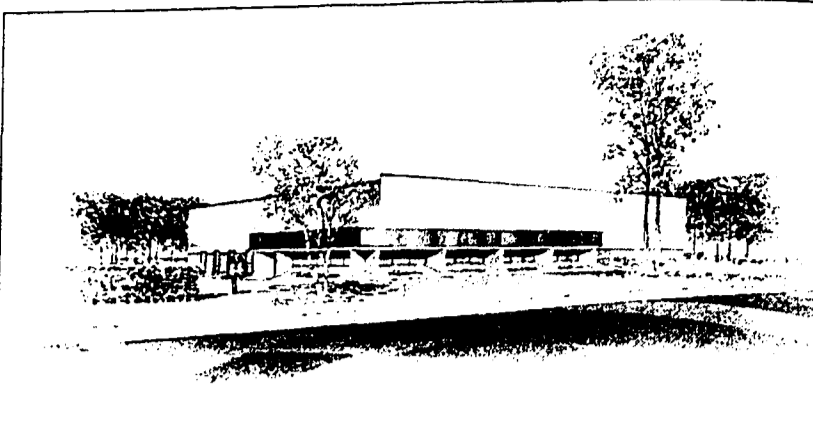

ROBERT A. DeMATTIA and F. Richard Duwel of Northville, president and vice-president of the R.A. DeMattia Company, announce construction of another facility in Metro-West Industrial Park at Five Mile and Sheldon Road in Plymouth Township.

The R.A. DeMattia Company broke ground August 9 for a 40,000 square foot regional office and distribution center for White and White, Inc., a division of White and White Surgical Supply and Pharmacies headquartered in Grand Rapids.

Hamilton Life Insurance Company, which is headquartered in Farmington Hills, said, "This significant investment by Alexander Hamilton Life Insurance Company helps continue jobs in Michigan and will help a respected company like Coca-Cola relocate into larger facilities."



DeMattia said he was impressed and appreciative of the probusiness attitude of the Van Buren Township elected officials. "We've been putting this package together for months," said DeMattia, "and the township officials have been aggressively cooperative in trying to win this distribution facility for Van Buren Township."

SALE

ON ARMSTRONG TRIM AND FIT FLOORS! Get a Trim and Fit Installation Kit FREE—with purchase.

Armstrong so nice to come home to. Connolly's Carpet CO. 9200 HIGHLAND ROAD (M-59) HOWELL, MI 48843

One local call places a want ad in over 64,000 homes through the following newspapers: Brighton Argus, County Argus/Pinckney Post, County Argus/Hartland Herald, Fowlerville Review, Livingston County Press.

RATES 10 Words for \$4.25. 23rd Per Word Over 10. Subst 35¢ for repeat. Insertion of same ad Classified Display.

BEST PRICES AVAILABLE On All Our In Ground Pools. FANTA-SEA Above Ground Pools. PIETILA POOLS 2549 E. Grand River, Howell.

Now 60 Channels Plus On Your TV Without Cable! Movies, Sports, News and More, 24 Hours a Day \$3495.00

Want a Bigger Ad? for your garage sale, to sell your home or for any reason. Ask for a GREENSHEET RATE BUSTER.

THE GREEN SHEET Classified advertising that reaches 84,000 homes every Wednesday, rain or shine.

This Size—\$54 Place your ad in The Green Sheet

The Green Sheet on Wednesday. The paper that tells you where to go in your local area to find this week's bargains.

Sliger/Livingston Publications GREEN SHEET EAST CLASSIFIED ADVERTISING

absolutely FREE. All items offered in this "Absolutely Free" column must be exactly that, free to those responding. 001 Absolutely Free. 002 Absolutely Free. 003 Absolutely Free.

NOTICES. 010 Special Notices. ALCOHOLICS Anonymous and Alcoholics Anonymous.

NICHOLS REALTY INC. 348-3044. NEW LISTINGS. Enchanting older home. Massive wood staircase.

Weir, Manuel, Snyder & Ranke. 498 South Main Street Plymouth Phone 458-2430

WOODLAKE VILLAGE BRIGHTON LIQUIDATION SALE. Fully renovated Sever. Water, Paing. Reduced Over 40%.

016 Found. CAMEL colored pocket folder. NORTHVILLE Highland Lakes Shopping Center. August 2 between 8:30 pm and 9:30 pm.

EARL KEIM REALTY BRIGHTON (313) 227-1311 or (313) 477-9505

James C. Cutler Realty 349-4030. Perfect location on exit ramp of I-14 — close to DETROIT and ANN ARBOR.

HISTORICAL DISTRICT Spacious 4 bedroom Victorian with parlor, dining room and basement. Partially restored. Separate efficiency apt. on first floor.

2 bedroom ranch with formal dining, 1 1/2 baths and basement. Double lot. Very private. \$58,000. Land Contract terms with \$15,000 down at 10% interest.

Carl Johnson Realty 349-3470. Spacious 2 bedroom all wood sided charter with ceramic bath, double lot, and garage.

021 Houses For Sale
BRIGHTON, 2 Owner 2800 sq. ft. 5 bedrooms, 2 1/2 baths, all amenities, near Borough Farms Resort and overlooking lake, all financing considered. \$189,900. (313)27-9596.

021 Houses
HOWELL, 3 bedroom home with attached garage, 1 1/2 baths, full basement, attached garage, 10 acres, full basement. \$200,000. (313)27-9596.

021 Houses
HAMBURG, For sale or rent, small 1 bedroom home with Buck Lake privileges. Available immediately. \$200 per month plus utilities. (313)27-9596.

021 Mobile Homes
BRIGHTON, 2 bedroom home with attached garage, 1 1/2 baths, full basement, attached garage, 10 acres, full basement. \$200,000. (313)27-9596.

021 Houses For Rent
BRIGHTON, 1 bedroom house for rent, fully furnished, adults preferred, no pets, \$250 per month. (313)27-9596.

RIZZO REALTY, INC. The Gallery of Homes 349-1515

NOVING REAL ESTATE INC. 201 S. Lafayette 437-2056

Century 21 EARL KAIM REALTOR BRIGHTON (313)227-1311 or (313)477-9505

021 Mobile Homes
BRIGHTON, 2 bedroom home with attached garage, 1 1/2 baths, full basement, attached garage, 10 acres, full basement. \$200,000. (313)27-9596.

\$100 DOWN
Grayling - Kalekka area, 10 acres, some adjoins State Land, beautiful hardwood forest, scenic view, large pond.

021 Houses For Rent
BRIGHTON, 1 bedroom house for rent, fully furnished, adults preferred, no pets, \$250 per month. (313)27-9596.

NORTHVILLE TWP. Picturesque setting with trees and privacy across from Meadowbrook Hills golf course about 1 acre, 4 bedroom, dining room, 3 1/2 baths, 2 fireplaces, family room, finished rear porch, dining room, LAND CONTRACT TERMS! \$89,900.

021 Houses For Sale
BRIGHTON, 2 bedroom home with attached garage, 1 1/2 baths, full basement, attached garage, 10 acres, full basement. \$200,000. (313)27-9596.

021 Houses
MILFORD, 3 bedroom home with attached garage, 1 1/2 baths, full basement, attached garage, 10 acres, full basement. \$200,000. (313)27-9596.

021 Mobile Homes
BRIGHTON, 2 bedroom home with attached garage, 1 1/2 baths, full basement, attached garage, 10 acres, full basement. \$200,000. (313)27-9596.

021 Houses For Rent
BRIGHTON, 1 bedroom house for rent, fully furnished, adults preferred, no pets, \$250 per month. (313)27-9596.

021 Houses For Sale
BRIGHTON, 2 bedroom home with attached garage, 1 1/2 baths, full basement, attached garage, 10 acres, full basement. \$200,000. (313)27-9596.

NORTHVILLE TWP. Very spacious 3 bedroom ranch in Lakes of Novi Custom built in 1980. Large family room with fireplace and down to 2 level walkout deck, dining room, country size kitchen. Newly landscaped and sodded. Quality throughout. \$118,500.

JUST REDUCED COUNTRY LIVING
BRIGHTON, 2 bedroom home with attached garage, 1 1/2 baths, full basement, attached garage, 10 acres, full basement. \$200,000. (313)27-9596.

021 Houses
MILFORD, 3 bedroom home with attached garage, 1 1/2 baths, full basement, attached garage, 10 acres, full basement. \$200,000. (313)27-9596.

021 Mobile Homes
BRIGHTON, 2 bedroom home with attached garage, 1 1/2 baths, full basement, attached garage, 10 acres, full basement. \$200,000. (313)27-9596.

021 Houses For Rent
BRIGHTON, 1 bedroom house for rent, fully furnished, adults preferred, no pets, \$250 per month. (313)27-9596.

021 Houses For Sale
BRIGHTON, 2 bedroom home with attached garage, 1 1/2 baths, full basement, attached garage, 10 acres, full basement. \$200,000. (313)27-9596.

HARTFORD SOUTH-WEST 22454 Pontiac Trail, South Lyon 348-6500

021 Houses
MILFORD, 3 bedroom home with attached garage, 1 1/2 baths, full basement, attached garage, 10 acres, full basement. \$200,000. (313)27-9596.

021 Mobile Homes
BRIGHTON, 2 bedroom home with attached garage, 1 1/2 baths, full basement, attached garage, 10 acres, full basement. \$200,000. (313)27-9596.

021 Houses For Rent
BRIGHTON, 1 bedroom house for rent, fully furnished, adults preferred, no pets, \$250 per month. (313)27-9596.

021 Houses For Sale
BRIGHTON, 2 bedroom home with attached garage, 1 1/2 baths, full basement, attached garage, 10 acres, full basement. \$200,000. (313)27-9596.

021 Houses For Rent
BRIGHTON, 1 bedroom house for rent, fully furnished, adults preferred, no pets, \$250 per month. (313)27-9596.

IMMACULATE LIKE NEW bi-level in South Lyon. 3 bedrooms, 2 1/2 baths, living room, fireplace, full finished basement, lovely deck off dining area, fenced yard, and like new above ground pool. Close to shopping, schools, church. \$59,900.

021 Houses
MILFORD, 3 bedroom home with attached garage, 1 1/2 baths, full basement, attached garage, 10 acres, full basement. \$200,000. (313)27-9596.

021 Mobile Homes
BRIGHTON, 2 bedroom home with attached garage, 1 1/2 baths, full basement, attached garage, 10 acres, full basement. \$200,000. (313)27-9596.

021 Houses For Rent
BRIGHTON, 1 bedroom house for rent, fully furnished, adults preferred, no pets, \$250 per month. (313)27-9596.

021 Houses For Sale
BRIGHTON, 2 bedroom home with attached garage, 1 1/2 baths, full basement, attached garage, 10 acres, full basement. \$200,000. (313)27-9596.

021 Houses For Rent
BRIGHTON, 1 bedroom house for rent, fully furnished, adults preferred, no pets, \$250 per month. (313)27-9596.

NOVI - 10 YEAR LAND CONTRACT available on this beautiful, well kept brick ranch over 1/2 acre tree lot, 3 bedrooms, 1 1/2 baths, kitchen and dining room with fireplace, finished basement. Close to schools and shopping. \$149,000.

021 Houses
MILFORD, 3 bedroom home with attached garage, 1 1/2 baths, full basement, attached garage, 10 acres, full basement. \$200,000. (313)27-9596.

021 Mobile Homes
BRIGHTON, 2 bedroom home with attached garage, 1 1/2 baths, full basement, attached garage, 10 acres, full basement. \$200,000. (313)27-9596.

021 Houses For Rent
BRIGHTON, 1 bedroom house for rent, fully furnished, adults preferred, no pets, \$250 per month. (313)27-9596.

021 Houses For Sale
BRIGHTON, 2 bedroom home with attached garage, 1 1/2 baths, full basement, attached garage, 10 acres, full basement. \$200,000. (313)27-9596.

021 Houses For Rent
BRIGHTON, 1 bedroom house for rent, fully furnished, adults preferred, no pets, \$250 per month. (313)27-9596.

SOUTH LYON - SHARP CONDO - Nicely decorated with 2 bedrooms, 1 1/2 baths, living room, large kitchen, partly finished basement. Walk to schools and shopping. Complete assumption of land contract terms. \$48,000.

021 Houses
MILFORD, 3 bedroom home with attached garage, 1 1/2 baths, full basement, attached garage, 10 acres, full basement. \$200,000. (313)27-9596.

021 Mobile Homes
BRIGHTON, 2 bedroom home with attached garage, 1 1/2 baths, full basement, attached garage, 10 acres, full basement. \$200,000. (313)27-9596.

021 Houses For Rent
BRIGHTON, 1 bedroom house for rent, fully furnished, adults preferred, no pets, \$250 per month. (313)27-9596.

021 Houses For Sale
BRIGHTON, 2 bedroom home with attached garage, 1 1/2 baths, full basement, attached garage, 10 acres, full basement. \$200,000. (313)27-9596.

021 Houses For Rent
BRIGHTON, 1 bedroom house for rent, fully furnished, adults preferred, no pets, \$250 per month. (313)27-9596.

the LIVINGSTON GROUP... DON'T RENT (OR BUY)! ...UNTIL YOU'VE SEEN THE NEW MOBILE HOME LIFESTYLE. ...OUR SALES TEAM OVER 40 THOROUGHLY TRAINED FULL-TIME SALESPEOPLE with more than 200 YEARS of Real Estate EXPERIENCE combined to form a dynamic energetic POWER HOUSE Real Estate Firm. For Professional Real Estate Counselling call: the LIVINGSTON GROUP Realtors... BRIGHTON 802 W. Grand River at Hacker 313 / 227-4600 HIGHLAND 1035 S. Milford Rd. 313 / 887-4118

Introducing Deluxe Ultra Lights

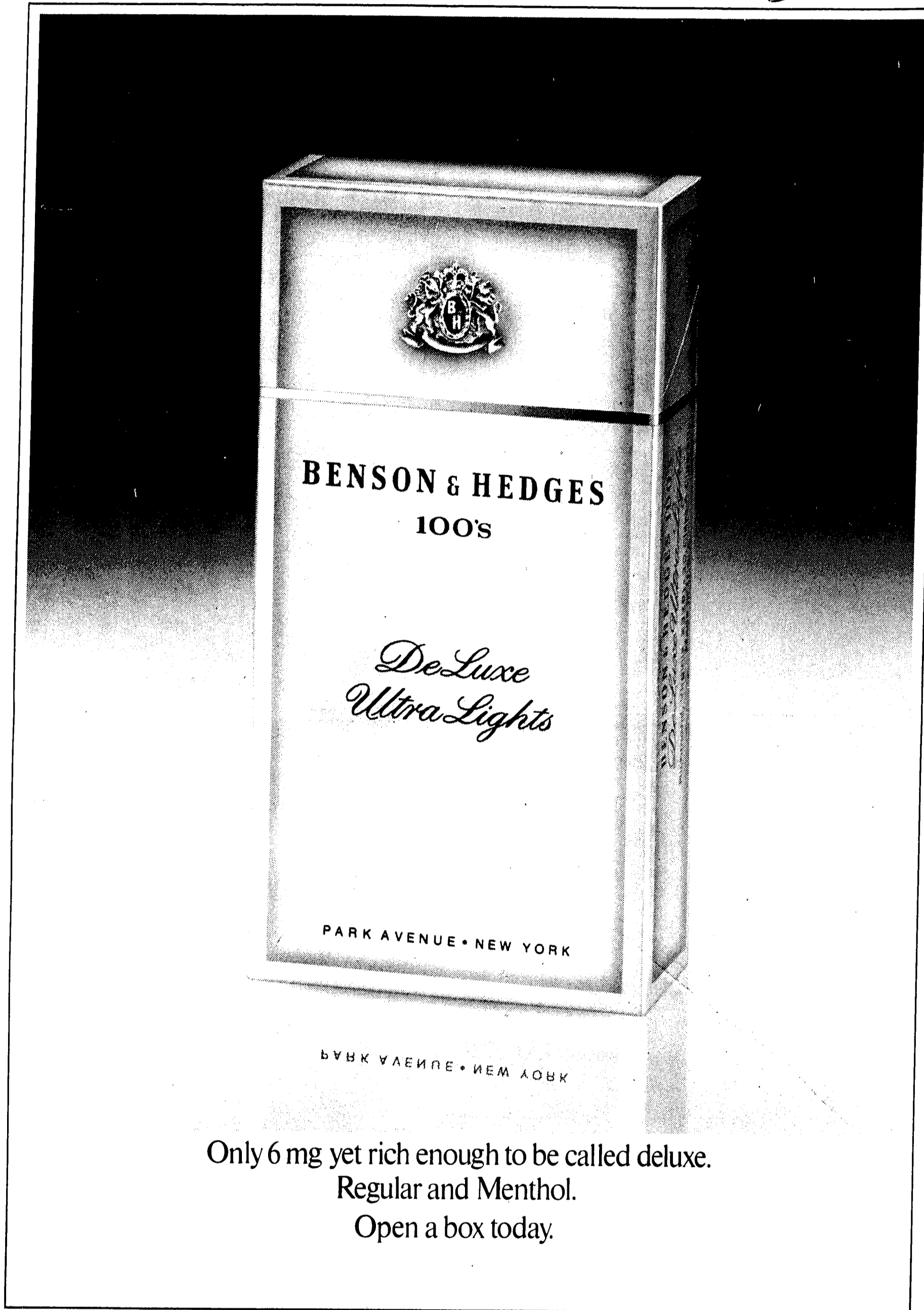

Only 6 mg yet rich enough to be called deluxe.
Regular and Menthol.
Open a box today.

BENSON & HEDGES

Warning: The Surgeon General Has Determined
That Cigarette Smoking Is Dangerous to Your Health.

6 mg "tar," 0.6 mg nicotine av. per cigarette, by FTC method.

DOUBLE COUPONS



THRU SATURDAY, AUGUST 14, 1982
Good on Manufacturer's "Cents-off" Coupons up to and including 50¢. Does not apply to A&P or Free Coupons or where the total exceeds the price of the item. Limit one coupon for any one product. All coupons more than 50¢ will be redeemed at face value. All coffee, cigarette, ham, turkey, and hamburger coupons excluded.

Prices Effective at
This A&P Store Only
41800 WEST TEN MILE
NOVI
OPEN 24 HOURS
8 A.M. MON. TO 11 P.M. SAT.
SUNDAY 9:30 A.M. TO 9 P.M.



**A&P's Having a
TRUCKLOAD SALE
4 BIG DAYS**
WED. AUG. 11 THRU SAT. AUG 14
CASE AND 10 LB. SAVINGS GALORE!

RED, RIPE, SUGAR SWEET, WHOLE

Plum-O-Rama
SWEET JUICY
Jumbo Plums
77¢
LB.

Watermelon
\$1.88
20-LB. AVERAGE
LIMIT 3

MICHIGAN GROWN TENDER
Green Cabbage
14¢
LB.

PEAT MOSS, BARK CHIPS OR
Top Soil
40 99¢
LB. BAG

MICHIGAN GROWN, U.S. NO. 1 NEW CROP
White Potatoes
8 69¢
LB. BAG

MANY BEAUTIFUL VARIETIES
Green Plants
97¢
4-IN. POT

BEAUTIFUL ASSORTED VARIETIES 36" TO 60" TALL
Show Plants
\$9.97
10-INCH POT
48" to 84" Tall Show Plants 14 INCH POT \$39.97

HAMBURGER MADE FROM
Ground Chuck
10 \$13.98
LB. PKG.

U.S.D.A. CHOICE
Boneless Chuck Steaks
10 \$15.98
LB. PKG.

ASSORTED
Pork Chops
10 \$14.98
LB. PKG.

NO BACKS ATTACHED — FRESH
Fryer Legs
10 \$5.68
LB. PKG.

PESCHKE
Sliced Bacon
10 \$16.98
LB. PKG.

\$1.00 REFUND AVAILABLE SEE STORE FOR DETAILS
Pabst Blue Ribbon Beer
24 \$8.49
12-OZ. CANS PLUS DEPOSIT

YUM YUM POTATO CHIPS 8-OZ. BAG 89¢
Seven-Up
8 \$1.79
16-OZ. BTL. PLUS DEPOSIT

A&P
Pork Sausage
10 \$8.98
LB. PKG.



ADVERTISED ITEM POLICY Each of these advertised items is required to be readily available for sale at or below the advertised price in each A&P Store, except as specifically noted in this ad.
Prices effective thru Saturday, August 14, 1982. Items offered for sale not available to other retail dealers or wholesalers. We reserve the right to limit quantities.

REDEEM ALL 3 COUPONS WITH ONE \$10 PURCHASE

SUPER COUPON
10¢ OFF LABEL
Roman Bleach
49¢
gal. btl.
A&P
LIMIT ONE WITH THIS COUPON AND ADDITIONAL \$5 PURCHASE
LIMIT ONE COUPON PER CUSTOMER
VALID THRU SATURDAY, AUGUST 14, 1982 699

SUPER COUPON
IODIZED OR PLAIN
Morton Salt
5¢
26-oz. ctn.
A&P
LIMIT ONE WITH THIS COUPON AND ADDITIONAL \$5 PURCHASE
LIMIT ONE COUPON PER CUSTOMER
VALID THRU SATURDAY, AUGUST 14, 1982 698

SUPER COUPON
VAL-U
Lowfat 2% Milk
\$1.39
plastic gallon
A&P
LIMIT ONE WITH THIS COUPON AND ADDITIONAL \$5 PURCHASE
LIMIT ONE COUPON PER CUSTOMER
VALID THRU SATURDAY, AUGUST 14, 1982 697

Our Pledge
Quality
WE UNCONDITIONALLY GUARANTEE THE QUALITY OF EVERYTHING WE SELL OR YOUR MONEY BACK. AND WE'RE SO SURE OF THE QUALITY OF OUR MEATS, PRODUCE AND DELI PRODUCTS, WE'LL DOUBLE YOUR MONEY BACK WITH PROOF OF PURCHASE IF YOU ARE NOT SATISFIED WITH THESE ITEMS.
PRICE: IF ANOTHER SUPERMARKET'S CURRENT NEWSPAPER ADVERTISED PRICE IS LOWER THAN OUR ADVERTISED PRICE ON AN IDENTICAL ITEM, JUST BRING IN THE AD AND WE WILL MATCH THE PRICE.
PRICE + QUALITY = VALUE
Guaranteed Value

Guaranteed Value!!

P&Q Specials
P&Q White Bread
39¢
20-oz. loaf

- P&Q Shortening 42-oz. can **\$1.39**
- P&Q Tea Bags 100-ct. pkg. **\$1.08**
- P&Q Ketchup 32-oz. btl. **99¢**
- P&Q Elbow Macaroni 32-oz. pkg. **79¢**
- P&Q Paper Plates 100-ct. pkg. **99¢**

P&Q Specials
P&Q Peanut Butter
\$1.39
18-oz. jar

- P&Q Light Bulbs 2-ct. pkg. **79¢**
- P&Q Paper Towels Jumbo Roll **57¢**
- P&Q Spaghetti Sauce 32-oz. jar **99¢**
- P&Q Toothpaste 7-oz. tube **79¢**

P&Q Specials
P&Q Iced Tea Mix
\$2.29
32-oz. can

Meat Specials
NO BACKS ATTACHED
Fresh Fryer Breasts
98¢
lb.

The Butcher Shop
With Supermarket Prices
NO BACKS
Fresh Fryer Legs
68¢
lb.
FLAT CUT
Boneless Rump Roast
\$1.88
lb.
SOLD AS ROAST ONLY
U.S.D.A. CHOICE GRAIN FED BEEF

Meat Specials
BOTTOM CUT
Boneless Round Steak
\$1.68
lb.
SOLD AS STEAK ONLY
U.S.D.A. CHOICE GRAIN FED BEEF

Frozen Specials
PLAIN, EGG, ONION OR HONEY & RAISIN
Lender's Bagels
59¢
10 to 12-oz. pkg.
MINUTE MAID ORANGE JUICE 16-oz. can **\$1.99**
HOMEMADE BUTTERMILK OR BLUEBERRY DOWNYFLAKE WAFFLES 12-oz. pkg. **69¢**
ANN PAGE FROZEN LEMONADE 4 6-oz. cans **\$4.00**
ASSORTED VARIETIES BANQUET COOK-IN-BAG 5-oz. pkg. **48¢**

ASSORTED
Pork Chops .. lb. **\$1.58**

BONELESS ROAST
Eye of Round lb. **\$2.98**
SOLD AS ROAST ONLY
U.S.D.A. CHOICE GRAIN FED BEEF

Frozen Specials
ASSORTED FLAVORS
Sealtest Sherbet
\$1.29
qt. ctn.

ROLL PORK (2-lbs. \$3.95)
Bob Evans Sausage ... 1-lb. roll **\$1.99**
WHOLE OR HALF
Pesckhe Stick Bologna lb. **\$1.18**
COUNTRY SMOKED
Center Cut Canadian Bacon lb. **\$3.49**
SHENANDOAH
Boneless Turkey lb. **\$1.49**
THORN APPLE VALLEY RED HOTS, KNACKWURST, RING BOLOGNA, POLISH OR
Smoked Sausage 12-oz. pkg. **\$1.88**

Grocery Specials
CUT OR FRENCH GREEN BEANS, WHOLE KERNEL OR CREAM STYLE CORN OR SWEET PEAS
Libby Vegetables
\$1.29
3 16-17-oz. cans
LIBBY Tomato Juice 40-oz. can **89¢**

Grocery Specials
Era Detergent
\$3.99
64-oz. btl.

MARKET BRAND Sliced Bacon lb. **\$1.38**
A&P THIN
Sliced Lunch Meat 2 3-oz. pkgs. **99¢**
BONNIE MAID COOKOUT
1/4 lb. Beef Patties 2-lb. pkg. **\$3.98**
MARVAL FRESH
Turkey Drums or Wings lb. **59¢**
CONTINENTAL
Boiled Ham 1-lb. pkg. **\$2.49**

Dairy Specials
MARGARINE
Soft Blue Bonnet 1-lb. pkg. **89¢**
BAY'S
English Muffins 12-oz. pkg. **88¢**
KRAFT COLBY OR MEDIUM
Kraft Cheddar 8-oz. pkg. **\$1.49**

Grocery Specials
SUNSHINE
Krispy Crackers
77¢
16-oz. box
CHEERI-AID ASSORTED FLAVORS Drink Mix 31-oz. canister **\$1.99**
WITH INSIDE COUPON

CHUNKY MIXED FRUIT, FRUIT COCKTAIL, SLICED OR PEACH HALVES OR PEAR HALVES
Libby Lite Fruit 16-17-oz. cans **79¢**
STOKELY LEMON-LIME
Gatorade 32-oz. btl. **89¢**
BUSH BEST
Baked Beans 55-oz. can **\$1.93**
MACARONI & CHEESE
Kraft Deluxe Dnr. 14-oz. pkg. **\$1.21**

PEACH, ORANGE, GRAPE OR FRUIT PUNCH
Hi-C Fruit Drinks 3 46-oz. cans **\$2.00**
KRAFT SALAD DRESSING
Miracle Whip 48-oz. jar **\$2.33**
FOR GREAT STEAKS
Heinz 57 Sauce ... 10-oz. btl. **\$1.89**
KRAFT
Barbecue Sauce ... 18-oz. btl. **\$1.18**

Dairy Specials
CHILLED
Minute Maid Orange Juice
\$1.59
64-oz. ctn.
Light 'N Lively Cottage Cheese 24-oz. ctn. **\$1.59**

Dairy Specials
STACK PACK AMERICAN CHEESE
Kraft Singles
\$2.19
1-lb. pkg.

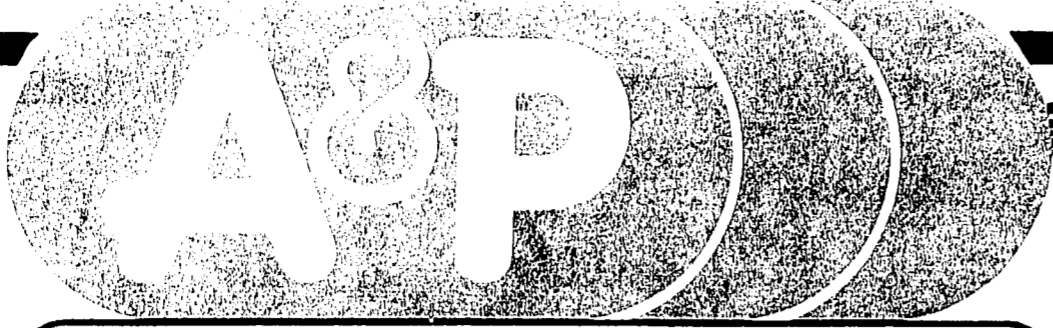

Each of these advertised items is required to be readily available for sale at or below the advertised price in each A&P Store, except as specifically noted in this ad.

Prices effective thru Saturday, Aug. 14, 1982. Items offered for sale not available to other retail dealers or wholesalers. We reserve the right to limit quantities.

HOME GROWN GOODNESS

FRESH FROM THE FARM

AT A&P

SWEET JUICY CALIFORNIA

Jumbo Nectarines

- ✗ NOT 96 SIZE
- ✗ NOT 72 SIZE
- ✓ JUMBO 64 SIZE

lb. **66¢**

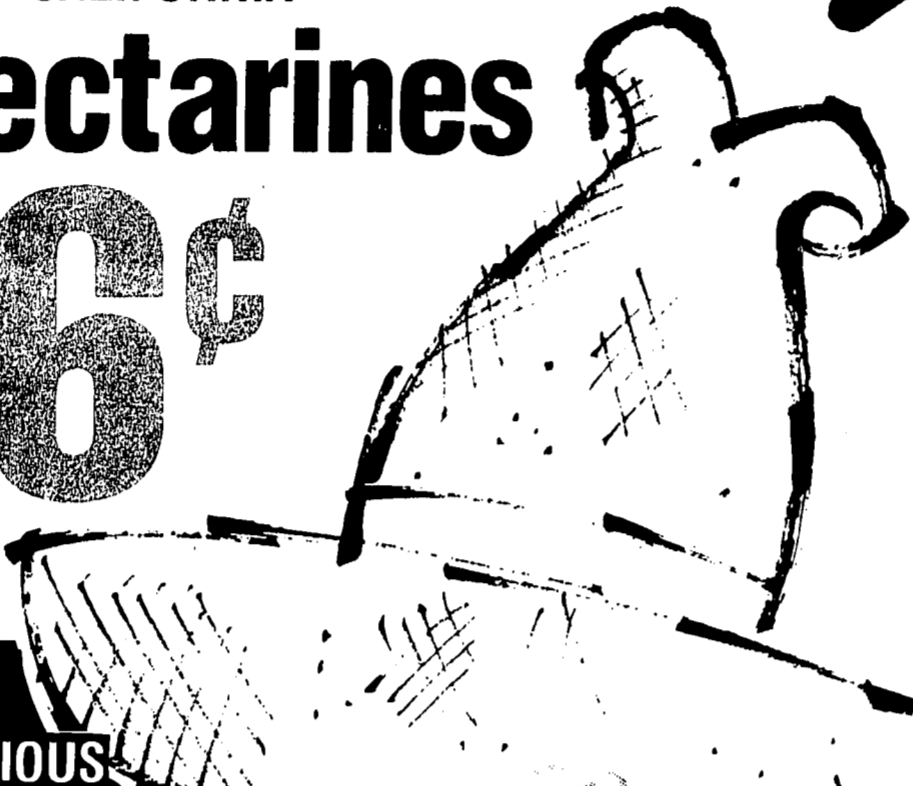

"NO DEPOSIT — NO RETURN"
ASSORTED VARIETIES TROPICANA

Fruit Drinks

4 10-oz. btl. **\$1**

SWEET LUSCIOUS CALIFORNIA THOMPSON

Seedless Grapes

lb. **88¢**



FULL OF JUICE, TANGY

Florida Limes ... **10** for **\$1**

Taste of the Tropics

GOLDEN RIPE

Bananas

lb. **28¢**

U.S. NO. 1 MILD
White Onions ... 2-lb. bag **97¢**
LARGE FLORIDA
Avocados ... each **77¢**

SALTED AND
Roasted Peanuts ... 10-oz. pkg. **97¢**

BEAUTIFUL
Green Plants \$1.49 4-inch pot

HEALTH & BEAUTY AIDS

Silkience Shampoo or Conditioner
REGULAR, MINT OR GEL
Crest Toothpaste
BUY TWO — GET TWO FREE TUBES WITH MANUFACTURERS REFUND.

\$1.59
7-oz. btl.



4 6.4-oz. tubes **\$3**

40% OFF LABEL
Signal Mouthwash

\$1.79
24-oz. btl.

ANTI PERSPIRANT

Dry Idea

\$1.59
1.5-oz. btl.

JOHNSON & JOHNSON
Baby Powder ... 24-oz. ctn. **\$2.59**

PLAYTEX
Hand saver Gloves ... pair **\$1.00**

Deli-Bake Shop

U.S. CHOICE
Roast Beef ... 1/2 lb. **\$2.29**



POTATO SALAD
5 lb. **\$2.98**

Bucket of Chicken 8 pieces **\$2.99**

American or Mustard Potato Salad ... lb. **89¢**
Wheat Bread ... loaf **69¢**
Ziggy's Smoked Sausage ... 1/2-lb. **\$1.49**
Sweet Rolls ... 3 for **99¢**
Roast Beef Sub Sandwich each **\$1.19**
Peach Pie ... each **\$1.89**

Your Choice: Wilson's Liver Cheese, Souse or Head Cheese ... 1/2-lb. **\$1.19**

AVAILABLE ONLY AT STORES WITH DELI-BAKE SHOP

SUPPLEMENT TO S.E.M. NEWSPAPERS INC., OBSERVE ECCENTRIC NEWSPAPERS, SLIGER NEWSPAPERS, DAILY TRIBUNE, YPSILANTI PRESS AND ASSOCIATED NEWSPAPERS.

YOU SAVE AT CHATHAM

We Gladly Redeem
U.S.D.A. Food Stamps.

OLE CAROLINA
SLICED
BACON



12-OZ.
PKG.

99c

GOVT. INSPECTED
FRESH PORK
SPARE RIBS



LB.

1.28

4-LB.
AVG.

ASSORTED FLAVORS
FAYGO CASE
POP SALE

24 399

1/2-LITER
BTLS.

PLUS
DEPOSIT

Cash
Dividend
SPECIAL

**DOUBLE
ON 5
MANUFACTURER
COUPONS**

ALL IT TAKES IS ONE
FILLED CASH DIVIDEND
CERTIFICATE

All coupons over 50¢ will be redeemed at face value. Amount to be refunded cannot exceed the cost of the coupon item. Limit 1 coupon for any 1 product. Retail store coupons and Free coupons excluded.

Cash
Dividend
SPECIAL

COTTONELLE
BATHROOM
TISSUE

4 ROLL
PKG.

69c

WITH 1 FILLED
CASH DIVIDEND
CERTIFICATE

Cash
Dividend

FREE!



FRESH
WHOLE
WATERMELON

EA.

1.99

22 TO 24-LB. AVG.

CHATHAM



ASSORTED FLAVORS
FAYGO POP
CASE SALE

24 HALF LITER BTLs. **3.99** PLUS DEPOSIT



WHITE OR PINK
TREESWEET
GRAPEFRUIT JUICE

1-QT. 14-OZ. CAN **69¢**



HARVEST INN
CUT GREEN BEANS

4 15½-OZ. CANS **\$1**

COOKIE SALE

- OATMEAL CREME 12.5-OZ.
- DOUBLE NUTTY 12-OZ.
- FUDGE NUTTY 12.5-OZ.

99¢ PKG.

- COCO CHOC. DROPS 13-OZ.
- ICED OATMEAL RAISIN 13-OZ.
- ICED OATMEAL PECAN 13-OZ.
- CHIPS DELUXE 12-OZ.

1.39 PKG.

M & M ROYALS 7.5-OZ. **1.19**
RITZ CRACKERS 1-LB. **1.39**



IVORY LIQUID

1-PT. 6-OZ. **1.19**

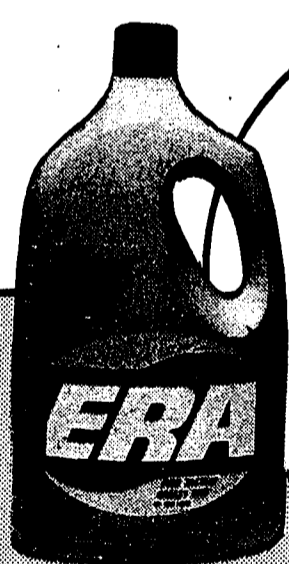

ERA DETERGENT

HALF GAL. **3.79**

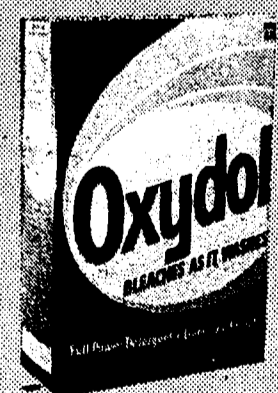

OXYDOL DETERGENT

5-LB. 4-OZ. **3.79**

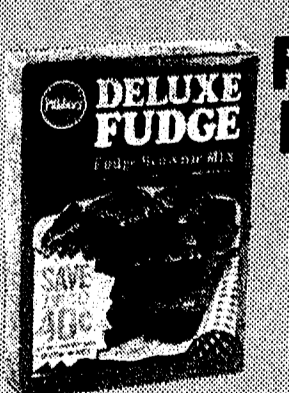

PILLSBURY FAMILY FUDGE BROWNIE MIX

1-LB. 6.5-OZ. **1.29**

SPRAY & WASH REFILL **2.19** QT.

REGULAR ECONOMY VETS DOG FOOD **44¢** 1-LB. 9-OZ.

25% OFF LABEL CALGONITE DOUBLE ACTION **2.43** 2-LB. 8-OZ.

ROYAL INSTANT PUDDING **43¢** 3½-OZ.

KRAFT DELUXE MAC & CHEESE **1.29** 14-OZ.

CAMP'S MAPLE SYRUP **1.66** 8.5-OZ.

Cash Dividend SPECIAL

CHUNK LIGHT BREAST O' CHICKEN TUNA

WATER OR OIL 6½-OZ. CAN

44¢

WITH 1 FILLED CASH DIVIDEND CERTIFICATE

Cash Dividend SPECIAL

KRAFT MIRACLE WHIP

QT. JAR

79¢

WITH 1 FILLED CASH DIVIDEND CERTIFICATE

Cash Dividend SPECIAL

SCOTT PAPER TOWELS

85-Ft. ROLL

9¢

WITH 1 FILLED CASH DIVIDEND CERTIFICATE

DOUBLE Cash Dividends FOR SENIOR CITIZENS PRESENT COUPON BELOW AND RECEIVE A PERMANENT CARD.

0000000 SENIOR CITIZENS PRESENT THIS CERTIFICATE AND RECEIVE A PERMANENT CARD FOR DOUBLE Cash Dividends

NAME: _____
ADDRESS: _____
CITY: _____

If you are 62 or older, redeem this certificate and get your permanent double Cash Dividend card.

DESIGNER OR DECORATOR BOUNTY TOWELS 85-Ft. ROLL **1.09**

30% OFF LABEL HEFTY SUPERWEIGHT TRASH BAGS 15 CT. **2.39**

PINE SOL LIQUID 1-Qt. 8-Oz. **2.99**

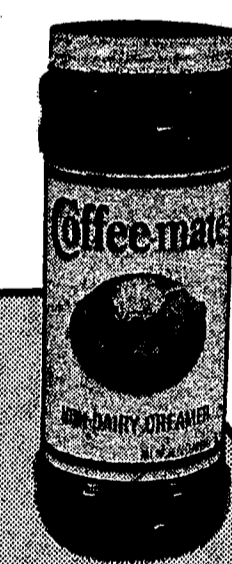

CARNATION COFFEE MATE

1-LB. 6-OZ. **1.99**



CHATHAM POLISH or KOSHER SPEARS

1-PT. 8-OZ. **1.19**

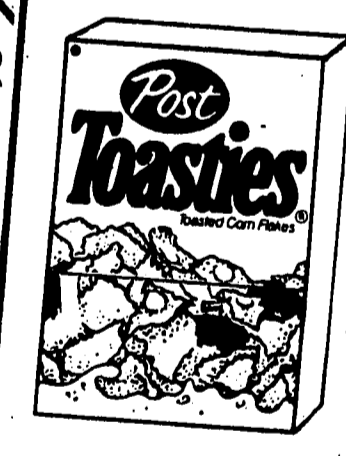

POST TOASTIES CEREAL

12-OZ. PKG. **69¢**



ASSORTED FLAVORS ROYAL GELATIN

3-OZ. PKG. **29¢**

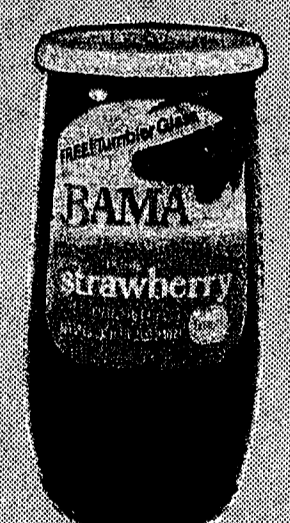

BAMA STRAWBERRY PRESERVES

1-LB. 2-OZ. JAR **99¢**



OCEAN SPRAY CRANAPPLE DRINK OR CRANBERRY JUICE COCKTAIL

QT. BTL. **99¢**

MCCORMICK BACON CHIPS 3.25-OZ. **1.07**

3-MIL GLAD TRASH BAGS 8 CT. **2.29**

BUTCHER BLEND DOG FOOD 4.5 LBS. **2.57**

LAWRY'S TACO SHELLS 10 CT. **39¢**

LOS PALMAS TACO SAUCE HOT OR MILD 8-OZ. **39¢**

LOS PALMAS REFRIED BEANS 1-LB. 1-OZ. **39¢**

OLD EL PASO NACHIPS CHEESE SAUCE 1-LB. 1-OZ. **1.89**

OLD EL PASO NACHIPS 7½-OZ. **99¢**

Cash Dividend SPECIAL

ALL PURPOSE
CRISCO
SHORTENING

3 LB. CAN **1.69**

WITH 1 FILLED CASH DIVIDEND CERTIFICATE

Cash Dividend SPECIAL

AMERICAN
KRAFT
SINGLES

12-OZ. PKG. **99c**

WITH 1 FILLED CASH DIVIDEND CERTIFICATE

BAKERY BUYS

HILLBILLY BREAD
1-LB. 4-OZ. LOAF **69c**

MASTER BAKERS
ITALIAN STYLE BREAD
1-LB. 4-OZ. LOAF **59c**

Fresh cut
CORN FED WESTERN BEEF

FRESH CUT BEEF
BONELESS RUMP ROAST

BOTTOM ROUND CUT LB. **1.77**

SOLD AS ROAST ONLY

OLE CAROLINA
SLICED BACON

12-OZ. PKG. **99c**

GOV'T. INSPECTED
FRESH PORK SPARE RIBS

4-LB. AVG. LB. **1.28**

20 BONUS Cash Dividends

WITH THE PURCHASE OF ...
1-LB. PKG.
OSCAR MAYER HOT DOGS

EFFECTIVE THRU AUG. 17, 1982. **CRATAM**

20 BONUS Cash Dividends

WITH THE PURCHASE OF ...
ANY PACKAGE SLICED or CHUB
OSCAR MAYER LUNCHEAT PRODUCT

EFFECTIVE THRU AUG. 17, 1982. **CRATAM**

HOME GROWN YELLOW
SWEET CORN DOZEN **88c**

GOLDEN RIPE BANANAS LB. **28c**

HOME GROWN CHERRY TOMATOES U.S. NO. 1 PT. **58c**

FRESH CRISP **PASCAL CELERY** STALK **48c**

MICHIGAN GROWN **SWEET BLUEBERRIES** 5 LB. CTN. **5.49**

Fresh cut
CORN FED WESTERN BEEF

FRESH CUT BEEF
BONELESS CUBED STEAK

FAMILY PACK 4 TO 6 LB. AVG. LB. **2.49**

U.S. GRADE A
CORNISH HENS

LB. **88c**

FRESH CUT BEEF
BONELESS EYE ROUND ROAST OR EYE ROUND STEAK

LB. **2.99**

JENNIE O VALUES

JENNIE O **WHITE TURKEY ROAST** 2 LB. BOX **2.99**

JENNIE O **WHITE/DARK TURKEY ROAST** 2 LB. BOX **2.49**

GLENDALE VALUES

GLENDALE CONTINENTAL **CORNED BEEF BRISKET** LB. **1.59** POINT CUT

GLENDALE **SMOKED SAUSAGE** LB. **1.79** 2 TO 3-LB. AVG.

GLENDALE CONTINENTAL BRAND **SLICED COOKED HAM** LB. **2.49**

FRESH! LAMB SALE

SHOULDER ROAST LB. **1.28**

SHOULDER BLADE CHOPS LB. **1.77**

SHOULDER ARM CHOPS LB. **1.87**

U.S. GRADE A
Honeysuckle
STED BONELESS TURKEY ROAST

LB. **1.48**

Fresh cut
CORN FED WESTERN BEEF

FRESH CUT BEEF
BONELESS BOTTOM ROUND STEAK LB. **1.88**

4 TO 6-LB. AVG.

FRESH FRYING CHICKEN
Certification No. A 005490

U.S. GRADE A FRESH
COUNTRY PRIDE CHICKEN WINGS OR THIGHS LB. **77c**

3 TO 5-LB. AVG.

FRESH ALL BEEF HAMBURGER
GROUND ROUND FAMILY PACK 4 TO 6 LB. AVG. LB. **1.89**

FRESH FROZEN **TURKEY DRUMSTICKS** LB. **33c**

HYGRADE BALL PARK MEAT FRANKS LB. 1.89 (BEEF 1.89)
THORN APPLE VALLEY MEAT HOT DOGS LB. 1.69 (BEEF 1.89)

Cash Dividend BUYING POWER

EASY AS... **1.** Pick up Cash Dividend saving certificate at our check-out counters. **2.** This week you get 1 Cash Dividend coupon for each \$1 you spend, excluding alcoholic beverages and tobacco products. Paste 36 Cash Dividend coupons on each certificate. **3.** Watch our ads each week for "Cash Dividend Specials". When you check, present one filled Cash Dividend certificate for each special you select.



JELLO PUDDING POPS
12 CT. PKG. **1.89**

ASSORTED FLAVORS
BANQUET CREAM PIES
14-OZ. **59c**



LARGE FAMILY SIZE
BANQUET FRIED CHICKEN
3-LB. 12-OZ. PKG. **3.99**

Specials!

LANCER GLASSWARE
FOR BEVERAGE, ROCKS, JUICE BY DURAND
3 FOR **99c**

DURAND COFFEE MUGS
2 FOR **1.99** CLEAR OR SMOKE
9" DIAMANT BOWL **1.99**



BORDEN'S ELSIE ICE CREAM
ASSORTED FLAVORS
SQUARE HALF GALLON **1.69**

MR. COFFEE COFFEE FILTERS
100 CT. **69c**

CEPACOL MOUTHWASH
1-PT. 8-OZ. **2.59**

NORMAL & OILY PERT SHAMPOO
11-OZ. **2.29**

LILT SPECIAL PERM KIT **2.97**

WHITE CHATHAM LEMONADE
6-OZ. CANS **5.1**

RICH'S COFFEE RICH
16-OZ. CTNS. **3.1**

CHATHAM

SHEDD'S
CORN OIL SPREAD
LB. TUB **2.99c**



Seafood PIER
FRESH SEAFOOD AVAILABLE WEDNESDAY THRU SATURDAY.

FRESH OCEAN PERCH FILLETS **1.99** LB.

FRESH LAKE SMELTS **99c** LB.



ASSORTED FLAVORS
BREYERS YOGURT
8-OZ. CTN. 3 FOR **1.39**



REGULAR OR CONDITIONING
HEAD & SHOULDERS SHAMPOO
15-OZ. **2.69** SAVE \$1.20



SECRET ROLL-ON DEODORANT
SCENTED OR UNSCENTED
1.5-OZ. **1.39** SAVE 30c



25% OFF LABEL
COLGATE TOOTHPASTE
7-OZ. TOOTHPASTE
8.4-OZ. GEL **1.29** SAVE 50c



MINUTE MAID ORANGE JUICE
HALF GAL. **1.89**

KRAFT AGED SLICED NATURAL SWISS
8-OZ. **1.69**

LAND O' LAKES GOLDEN VELVET CHEESE SPREAD
2 LB. LOAF **2.99**



SCHICK PLUS PLATINUM BLADES
DOUBLE EDGE
5-CT. 3 PKGS. FOR **1.39** SAVE 48c ON 3



SWAN PEROXIDE
8-OZ. 4 FOR **1.39** SAVE 56c ON 4

CHATHAM Super... SANDWICH SALE



world
wide
deli



AT CHATHAM'S DELIS BUY IT BY THE
POUND AND SAVE!

Cash
Dividend
SPECIAL

ONE POUND...

- ✓ POTATO SALAD
- ✓ COLE SLAW
- ✓ MACARONI SALAD

Your Choice

FREE

WITH 1 FILLED
CASH DIVIDEND
CERTIFICATE

WISCONSIN
**MUENSTER
CHEESE**

299
LB.

EKCRICH
**OLD FASHION
LOAF**

339
LB. IN UNITS
OF 1-LB.
OR OVER

HOME STYLE
**MEAT
BOLOGNA**

199
LB. IN UNITS
OF 1-LB.
OR OVER

ALL WHITE MEAT
**BREAST OF
TURKEY**

399
LB. IN UNITS
OF 1-LB.
OR OVER

OLIVE, PICKLE OR
**PIMENTO
LOAF**

269
LB.

PLUS...DOUBLE CASH DIVIDENDS ON ALL DELI PURCHASES!

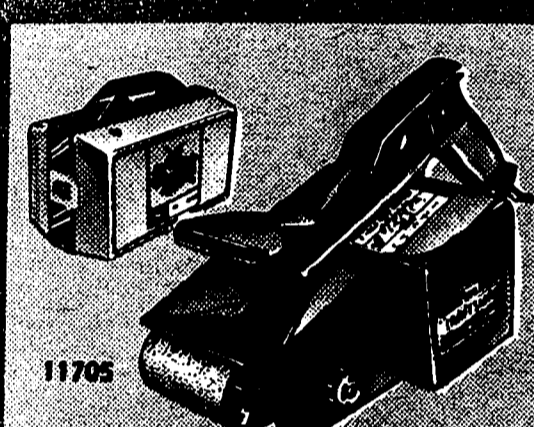

11705

SAVE \$46 on belt sander and case

Craftsman 3-inch belt sander. Reg. sep. prices total \$96.99.

49⁹⁹

Sanding belt
3/21-in. F.M.P. C. Reg. \$1.99.

99⁹⁹

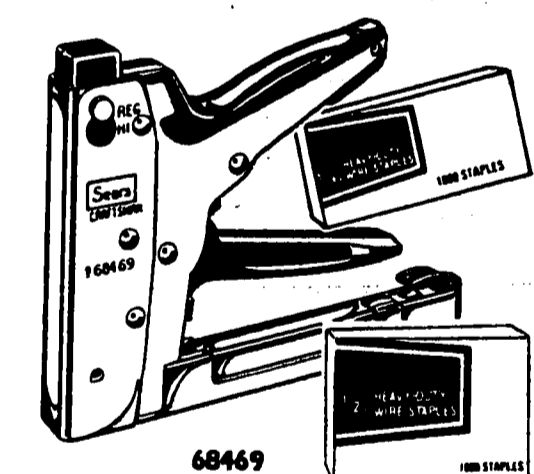

68469

SAVE over 50% stapler gun

Reg. sep. prices total \$21.77.

9⁹⁹

With box of 1000, 5/16-in. staples and box of 1000, 1/2-in. staples.

Sale ends Aug. 21 or while quantities last.



74799

SAVE 53% on riveter and rivets

Reg. sep. prices total \$23.78.

9⁹⁹

Right-angle riveter with 35, 1/16-in. aluminum rivets.

Sale ends Aug. 21 or while quantities last.

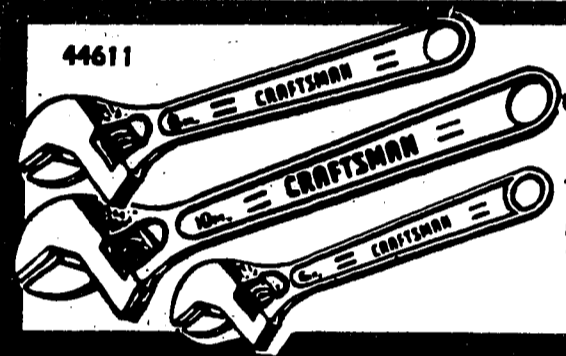

44611

SAVE 56%

Craftsman 3-pc. wrench set

Includes 6, 8 and 10-inch adjustable wrenches. Nickel-chrome plated.

Reg. sep. prices total \$34.97.

12⁹⁹

Sale ends Aug. 21 or while quantities last.

Sears

**CRAFTSMAN
POWER
WEEK
SALE**

Craftsman... the big name in quality tools for over 55 years

SOLD ONLY AT SEARS!

Hurry... sale ends Saturday

(except where noted)



SAVE UP TO 50% on Craftsman hand tools

39215 Most items at reduced prices

3820

\$14.99, 16-oz. curved-claw hammer..... 7.99

\$22.99, 26-in. hand saw..... 11.49

\$12.99, 3/4-in. x 16-ft. tape..... 6.99

36193-4

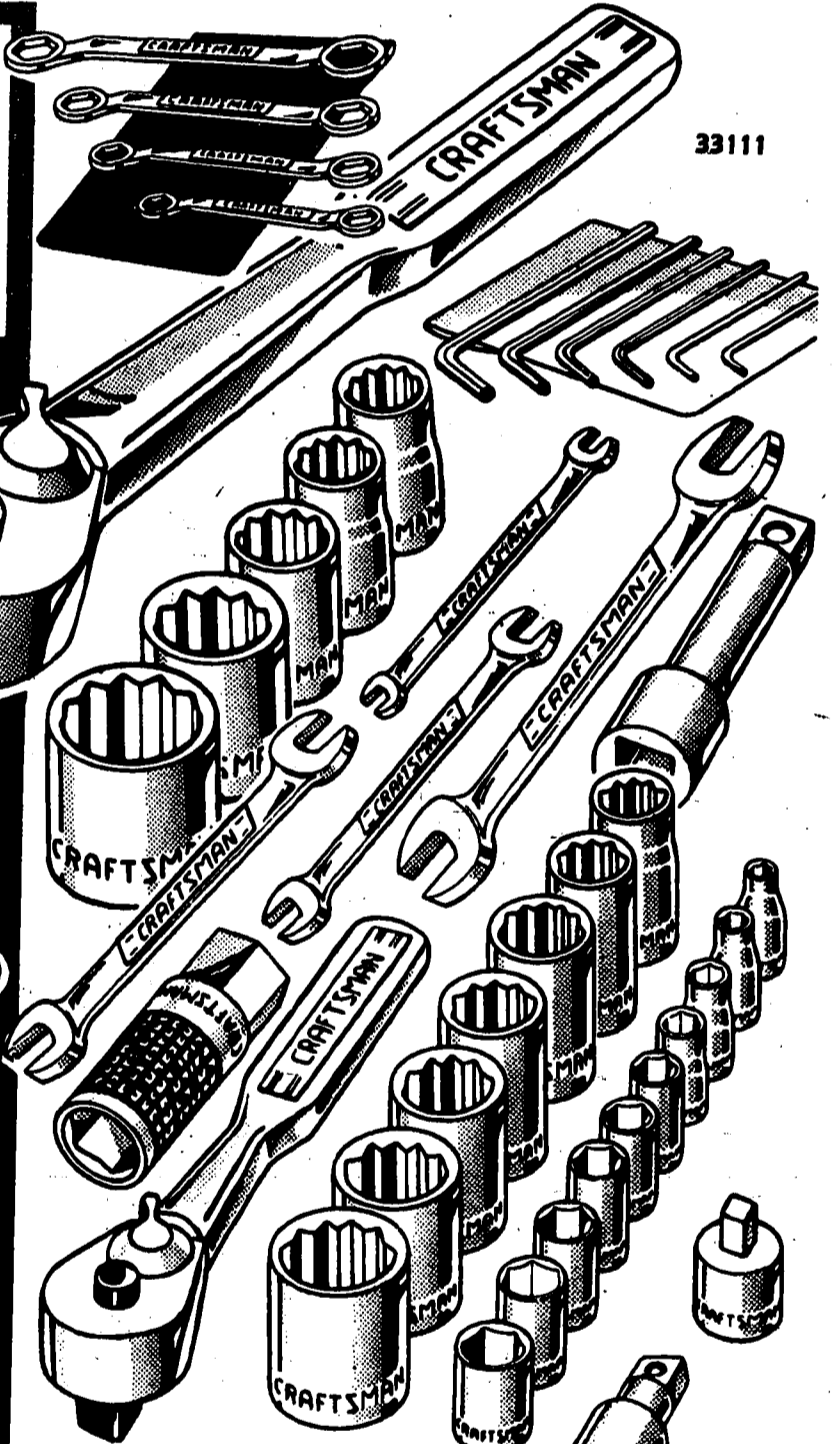

SAVE \$80

Craftsman® 42-pc. tool set

Great for home and auto. Includes two quick-release ratchets; 1/4, 3/8 and 1/2-inch drive sockets; wrenches and more.

Regular separate prices total \$120.96

39⁹⁹

Craftsman Hand Tool Full Unlimited Warranty

If any Craftsman hand tool ever fails to give complete satisfaction, return it for free replacement.

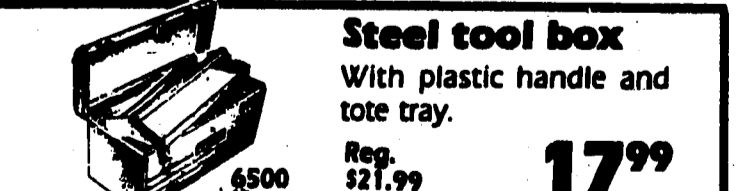

Steel tool box

With plastic handle and tote tray.

Reg. \$21.99

17⁹⁹



Craftsman 15-pc. accessory set

Add metric tools to your standard set.

Reg. sep. prices total \$40.95

15⁹⁹

Sears Pricing Policy: If an item is not described as reduced or a special purchase, it is at its regular price. A special purchase, though not reduced, is an exceptional value.

Sears has a credit plan to suit most any need

Sears

CRAFTSMAN
WEEK
SALE

SAVE \$25-\$40
on these Craftsman® portable tools

Save 50%
on these workshop tools

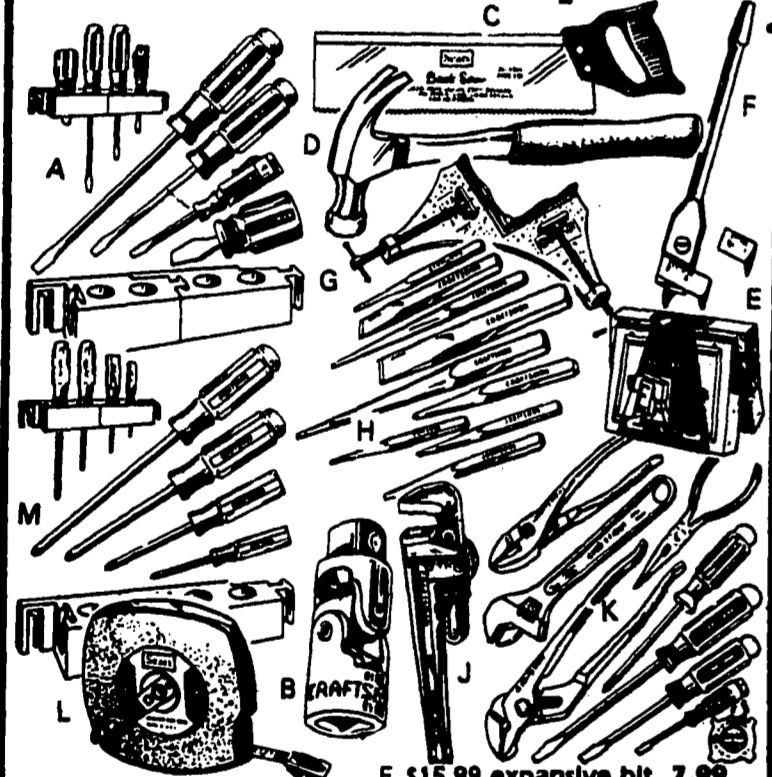

- A. \$12.36*, 4-pc. slotted screwdriver set**...6.18
 - B. \$6.99-\$7.99 universal joints chisel set**...16.99
 - C. \$9.49 back saw...4.74
 - D. \$11.99, hammer...5.99
 - E. \$5.49 sawhorse brackets, 2 pcs...2.74
 - F. \$15.99 expansive bit screwdriver set**...3.49
 - G. \$6.99 corner clamp...6.18
 - H. \$40.48*, 9-pc. punch and chisel set**...16.99
 - J. \$11.99, pipe wrench**5.99
 - K. \$51.01*, 9-pc. toolset**...19.99
 - L. \$10.99, x 50-ft. tape .549
 - M. \$17.36*, 4-pc. Phillips screwdriver set**...6.88
- *Regular separate prices total
**A Craftsman tool

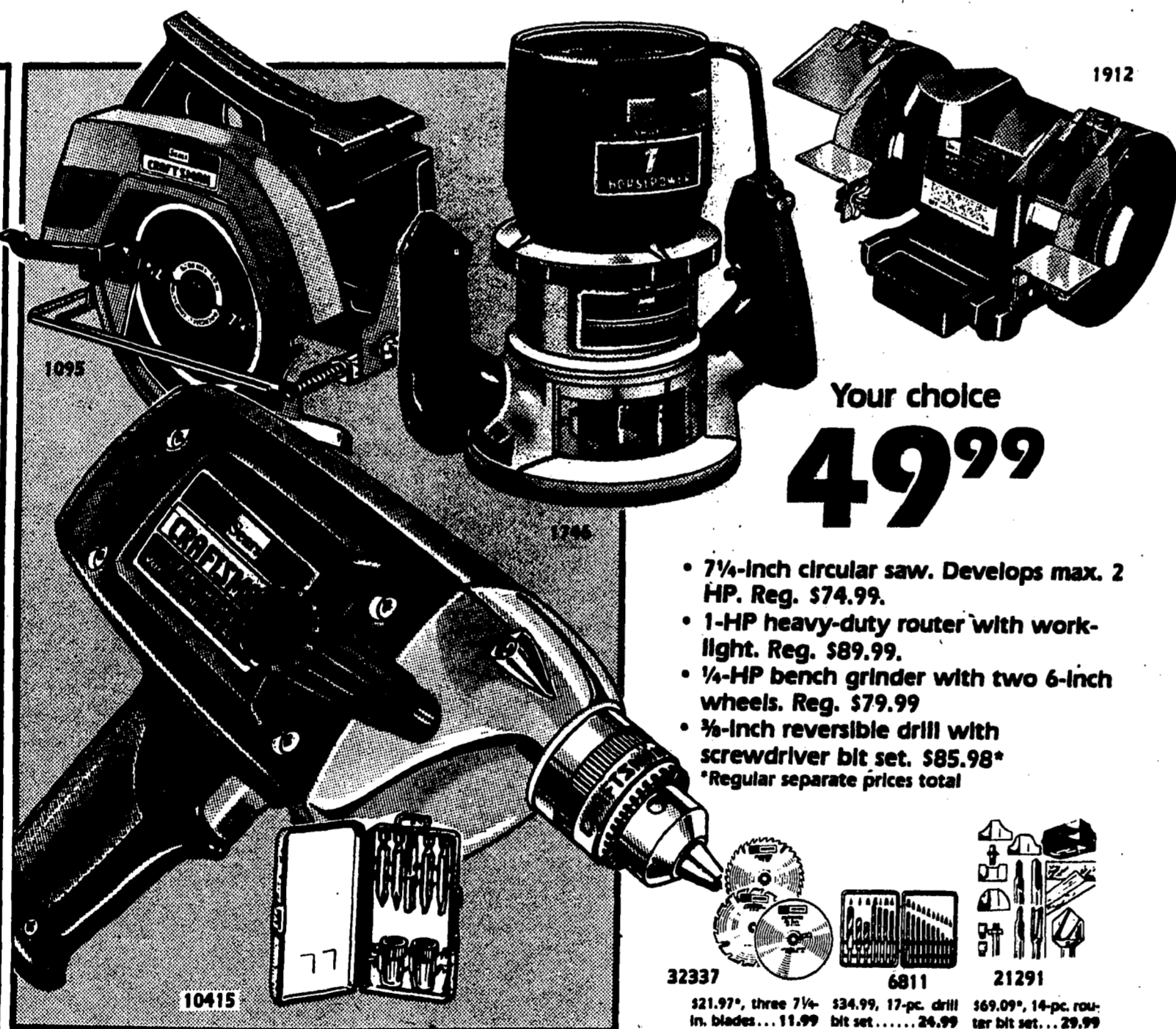

Your choice
49⁹⁹

- 7¼-inch circular saw. Develops max. 2 HP. Reg. \$74.99.
 - 1-HP heavy-duty router with work-light. Reg. \$89.99.
 - ½-HP bench grinder with two 6-inch wheels. Reg. \$79.99.
 - ¾-inch reversible drill with screwdriver bit set. \$85.98*
- *Regular separate prices total

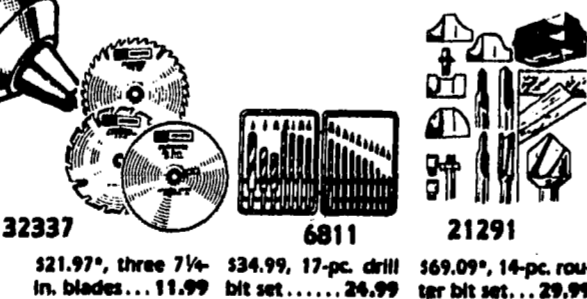

Sale ends Aug. 14

FOR EMERGENCIES

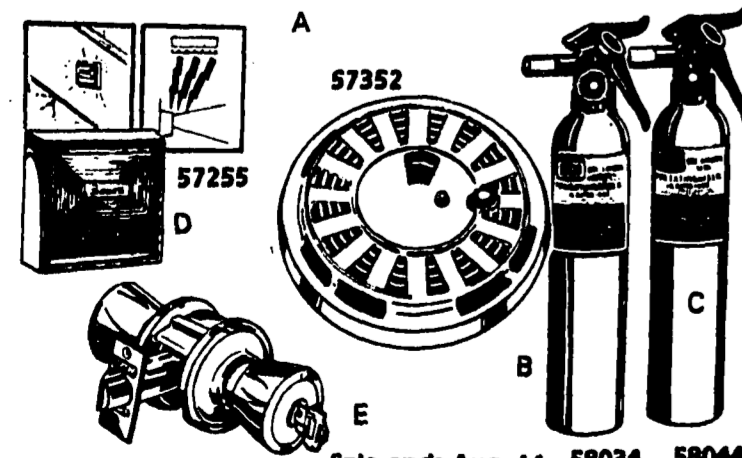

- A. \$16.99 smoke detector...12.99
- B. Rated 10-B-C fire extinguisher. Sears price...9.97
- C. \$17.99, 1A; 10-B-C extinguisher...12.99
- D. \$12.99 Sound-activated light...9.99
- E. \$12.99 or \$14.99 lock set...9.99-\$10.99

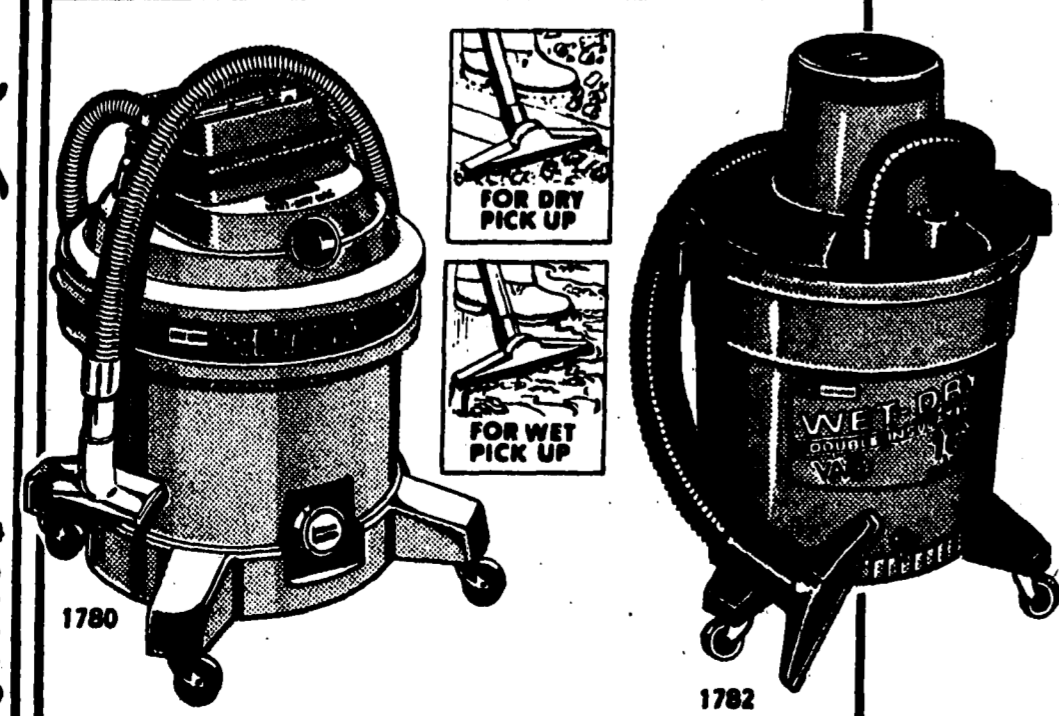

SAVE \$20-\$50
on Craftsman wet/dry vacs

8-gal. size vac
With hose, nozzle, casters. Reg. \$89.99
69⁹⁹
\$27.99, 6-pc. accessory kit...19.99

16-gal. size vac
With hose, nozzle, casters. Reg. \$149.99
99⁹⁹
\$29.99, 6-pc. accessory kit...24.99
Sale ends Aug. 25

SAVE \$120-\$150
on Craftsman® bench power tools

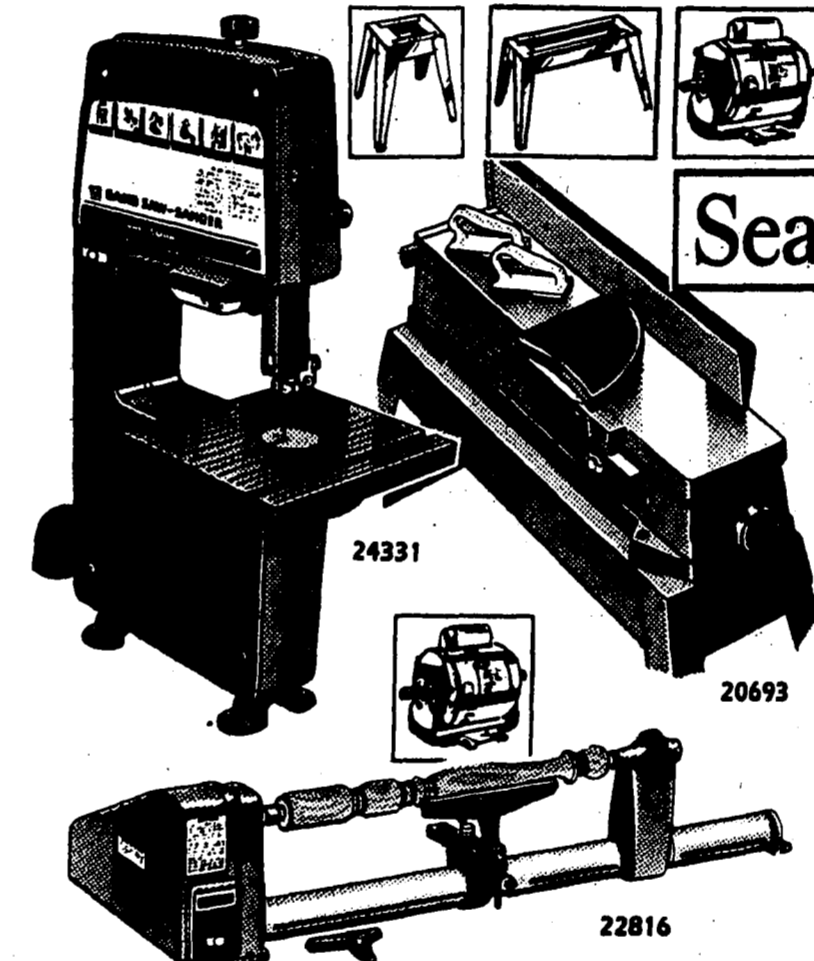

SAVE \$70-\$100
on these specialty tools

- Craftsman 12-inch wood lathe. Capacitor-start, 1725-rpm, ½-HP motor. Four motor pulley speeds. Reg. \$299.99. **199⁹⁹**
- Craftsman band saw-sander. 12-inch outfit with steel leg set. Capacitor-start ½-HP motor. Reg. \$419.99. **349⁹⁹**
- Craftsman jointer-planer. With steel leg set. Cast-iron top. Capacitor-start ½-HP motor. Reg. \$419.99. **349⁹⁹**

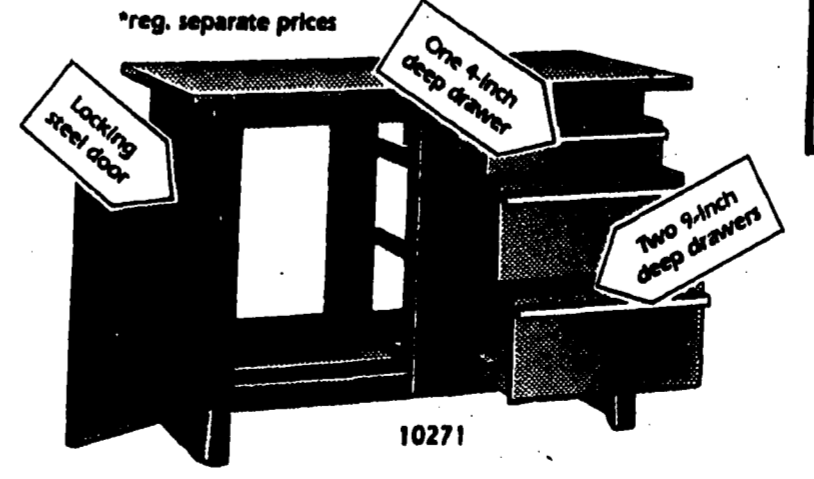

SAVE '98 on Craftsman workbench combination
Sturdy steel frame. Hardboard top. Unassembled. Reg. sep. prices total \$178.94* **99⁹⁹**
Sale ends Aug. 21

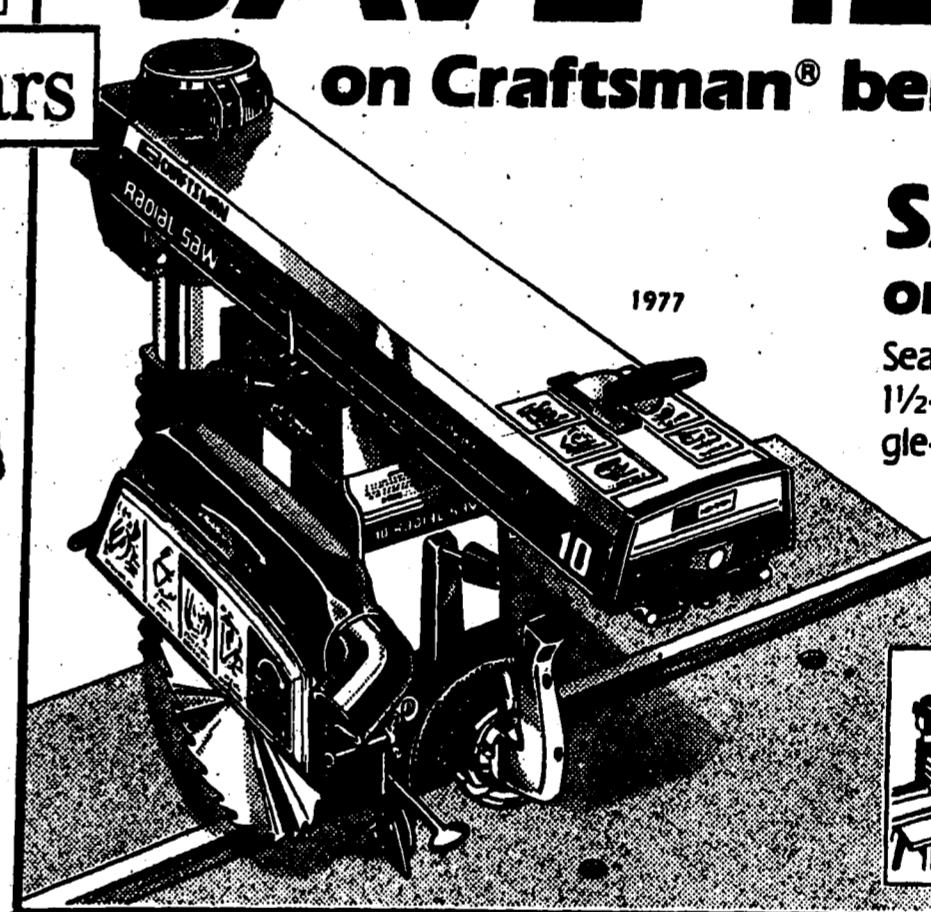

SAVE \$150
on 10-inch radial saw
Sears Best radial saw with capacitor-start 1½-HP motor that develops 2½ HP. Single-lever upfront miter controls.
Regular \$449.99

299⁹⁹

Bench power tools come partially assembled.
Leg set extra

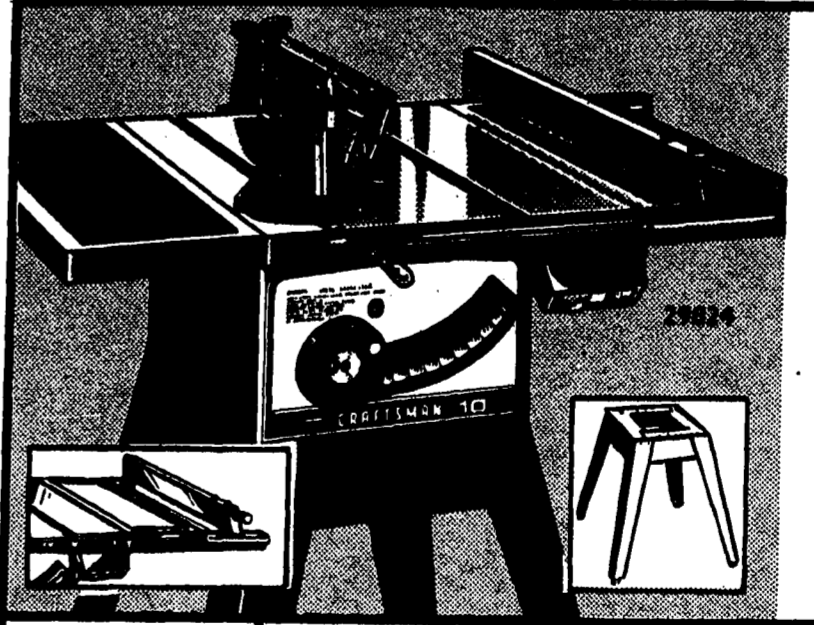

SAVE \$145
on 10-inch table saw
With steel leg set and two table extensions. Capacitor-start 1-HP ball-bearing motor develops 2 HP.

Reg. sep. prices total \$494.98 **349⁸⁸**

Sale prices end Aug. 28 except where noted

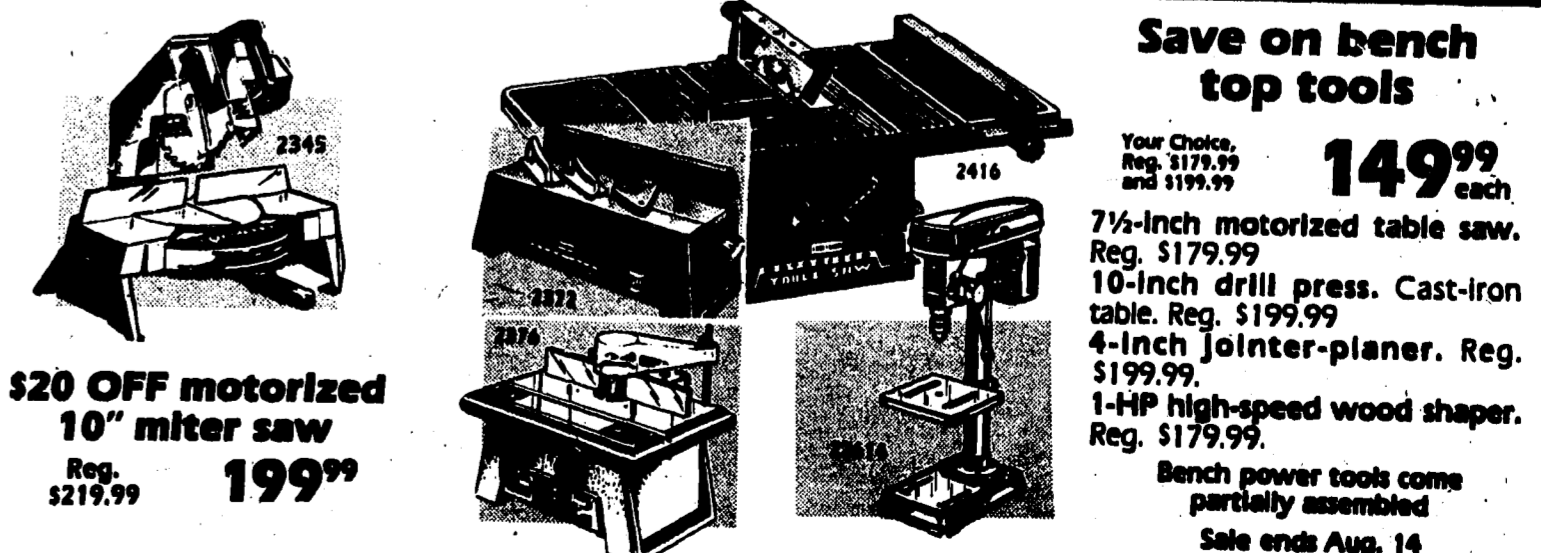

Save on bench top tools

Your Choice, Reg. \$179.99 and \$199.99 **149⁹⁹** each
7½-inch motorized table saw. Reg. \$179.99
10-inch drill press. Cast-iron table. Reg. \$199.99
4-inch jointer-planer. Reg. \$199.99
1-HP high-speed wood shaper. Reg. \$179.99
Bench power tools come partially assembled
Sale ends Aug. 14

Sears

**CRAFTSMAN
POWER
WEEK
SALE**

SAVE \$211
on this Craftsman® 133-piece tool set

SAVE \$90

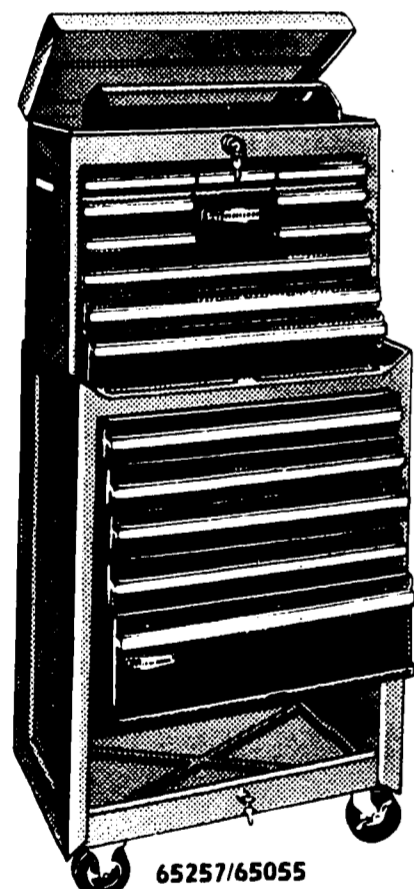

on Craftsman chest-cabinet combination

10-drawer chest and 5-drawer cabinet with top and bottom compartments. Casters, locks.

Chest Reg. \$219.99
Cabinet Reg. \$249.99
179⁹⁹
199⁹⁹

Sale ends Aug. 14
\$9.99 sliding tray... 7.99
\$18.99 work surface... 14.99
\$27.99 cantilever tray... 22.99
\$9.99 chest drawer liner... 7.99
\$10.99 cabinet drawer liner... 7.99
\$5.49 chest drawer dividers, pkg. of four... 4.49
\$6.99 cabinet drawer dividers, pkg. of four... 5.99
Sale ends Aug. 25

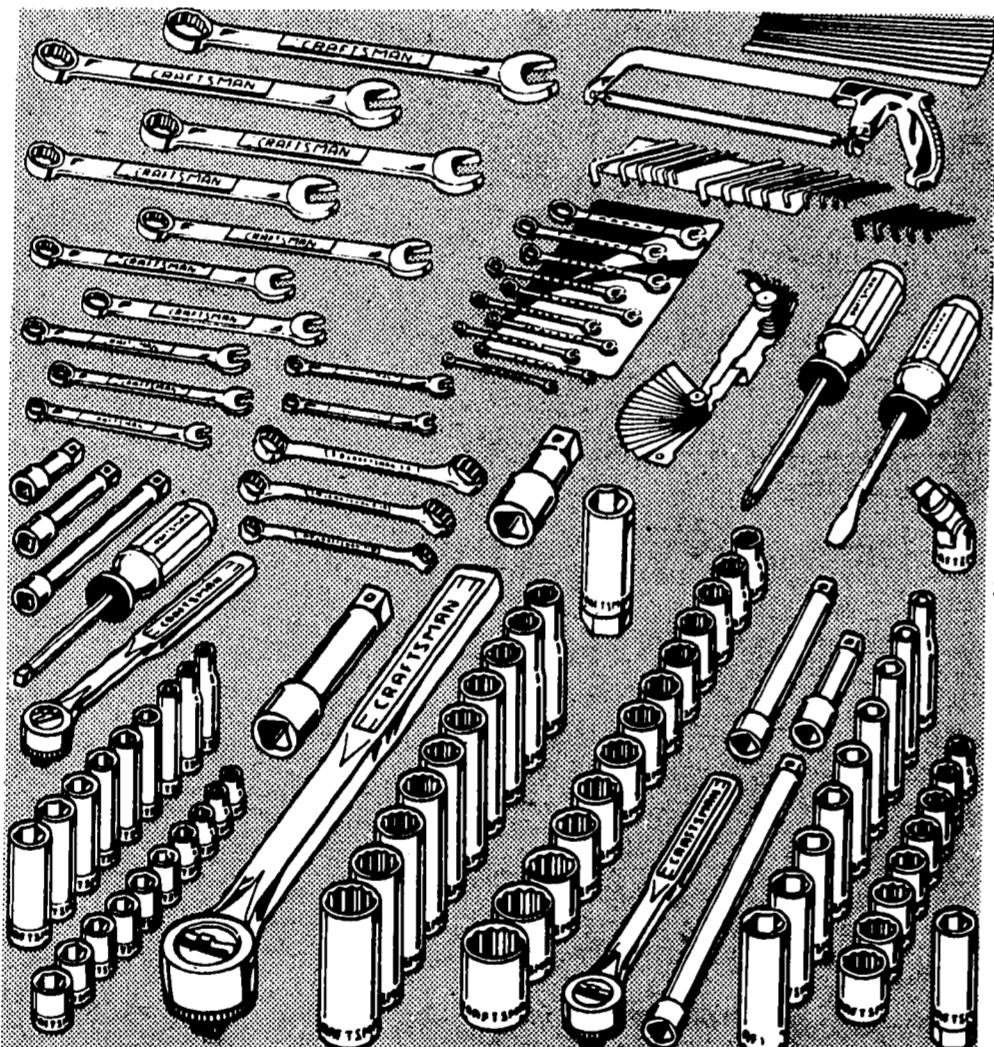

For home and auto jobs, big and small

Regular separate prices total \$411.10

199⁹⁹

Includes three fine-tooth quick-release ratchets; 1/4, 3/8 and 1/2-in. drive regular and deep-depth sockets; extension bars; wrenches; and more.

Sale ends Aug. 28

Craftsman Hand Tool Full Unlimited Warranty
If any Craftsman hand tool ever fails to give complete satisfaction, return it for free replacement.

Your choice \$9

A. \$12.99, 7-in. linemen's pliers**
B. \$13.99, 13-in. Arc-Joint® pliers**
C. \$21.99, 6-pc. screwdriver set**
D. \$12.99, 1-in. x 25-ft. tape**
E. \$15.99, 1-in. x 25-ft. tape**
F. \$12.99, hole saw starter kit

H. \$10.99, 3-pc. plug cutter set
J. \$13.99, 6-pc. reciprocating saw blade pack
K. \$15.99, Torx® screwdriver**
L. \$17.99, torque wrench**
M. \$14.99, flex handle

*Regular separate prices total
**A fine Craftsman hand tool

Sale ends Aug. 14

Reg. separate prices total \$104.76
49⁹⁹

Craftsman 34-piece metric accessory set of sockets and wrenches.

Sale ends Aug. 14

4-cu. ft. wheelbarrow Reg. \$64.99 **44⁹⁹**

Pulsator sprinkler Reg. \$10.99 **7⁹⁹**

Oscilling sprinkler Reg. \$11.99 **8⁹⁹**

Craftsman tools Your choice \$29⁹⁹

A. \$44.99, 12-pc. socket set
B. \$69.99, 22-pc. socket wrench set
C. \$50.18* std./metric 12-pc. wrench set
D. \$49.99 torque wrench

*Regular separate price total

Your choice \$6⁹⁹
Craftsman lawn, garden tools
\$10.99 dual-purpose rake
\$10.99 long-handle shovel
\$10.99 weevil cutter
\$9.99 one-wheel edger

Sale ends Aug. 14

SAVE \$100 on
10-HP electric-start riding mower with 30-inch mower deck
Reg. \$999.99



899⁹⁹

Self-bagger not included
• Iso-Vib engine mounts help reduce vibration
• 30-in. floating deck helps prevent scalping of lawn
• In-line transmission
• 5 forward, 1 reverse speeds
Self-bagger, Reg. \$199.99 179.99
Also available at Brighton and Howell stores

SAVE \$50
on this Eager-1® 3.5 RP rear-bag mower with catcher



Sale ends Aug. 18 or while 100 last

Reg. \$249.99
199⁹⁹

• Solid-state ignition
• Gear-assist starter
• Quick height adjusters
• Non-rusting gas tank

SAVE \$3
Craftsman 2 1/2-gal. gas can
Reg. \$9.99 **6⁹⁹**

SAVE \$150
on 10-HP lawn tractor

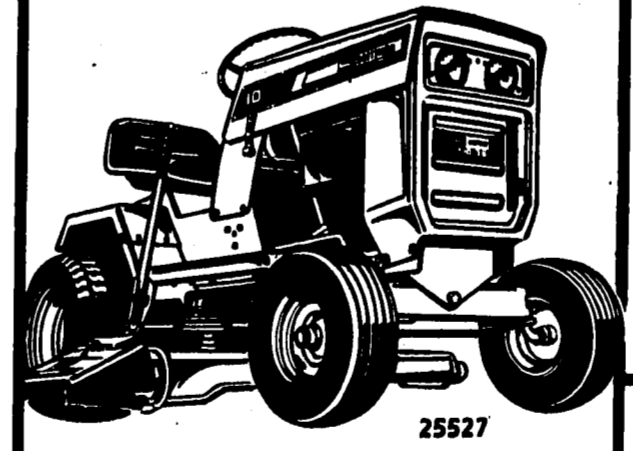

with 36-in. mower deck
Electric-start; Iso-Vib engine mounts help reduce vibrations. 36-inch mower deck helps prevent scalping. Rugged 3-speed transaxle.

Reg. \$1149.99
999⁹⁹
Sale ends Aug. 21

SAVE \$15 Craftsman electric chain saw



2-HP, 14-inch. Lo-Kick guide bar. Manual oiler.
Reg. \$94.99
79⁹⁹
Sale ends Aug. 28

SAVE \$2.99 on 2.0 cu. in. gas chain saw with case
Has 14-in. Lo-Kick guide bar; auto. chain oiler.
Reg. \$12.99
16⁹⁹
Partially assembled Sale ends Aug. 28

15 or 40 watt Bugwacker® bugkillers
A. 40-watt. Lures insects up to 110-ft. Reg. \$129.99 ... **99.99**
B. Bugwacker. Lures insects up to 70-ft. **54.99**
Sale ends Aug. 14

SAVE \$5
2-gal. sprayer
Galvanized steel resists rust. Funnel top design.
Reg. \$21.99
16⁹⁹
Sale ends Aug. 21

YARD POWER, GARDEN ITEMS

\$25 OFF Craftsman electric edger
Reg. \$94.99
69⁹⁹
Heavy-duty, high torque permanent magnet motor develops 1.0-HP. 7 1/2-in. blade. Insulated.
Sale ends Aug. 21

\$20 OFF Electric Weed-wacker
Reg. \$59.99
39⁹⁹
3/4-HP electric motor. Cuts a full 16" diameter swath. Semi-automatic line feed. UL listed.

\$5 OFF gas Weedwacker®
Reg. \$114.99
109⁹⁹

\$40 OFF gas Weedwacker®
Reg. \$159.99
119⁹⁹

\$20 OFF Weedwacker-trimmer
Reg. \$199.99
179⁹⁹

\$15 OFF Bushwacker-trimmer
Reg. \$59.99
44⁹⁹

5/8" dia. Rubber Garden Hose
50', Reg. \$27.99... 16.99
75', Reg. \$39.99... 27.99
100', Reg. \$49.99... 35.99

\$1 OFF Weed-wacker line spool
Reg. \$5.99
4⁹⁹

Sears

SAVE \$60 or \$100 on Sears Kenmore® dishwashers

Stainless steel hoods also on sale!

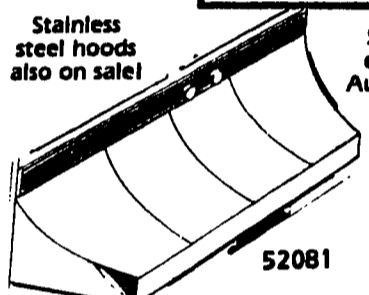

SAVE \$20

30-in. Kenmore range hood
200 CFM. Vented/ventless installation. White, colors.
Reg. \$109.95 **89⁹⁵**

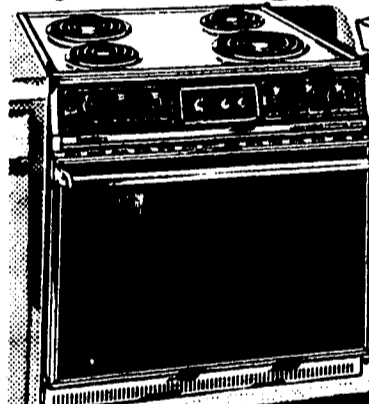

45325 **SAVE \$100**
on Kenmore electric drop-in range
Automatic delay, start and off oven. 30-in.
Reg. \$569.95 **469⁹⁵**
Sale ends Aug. 14

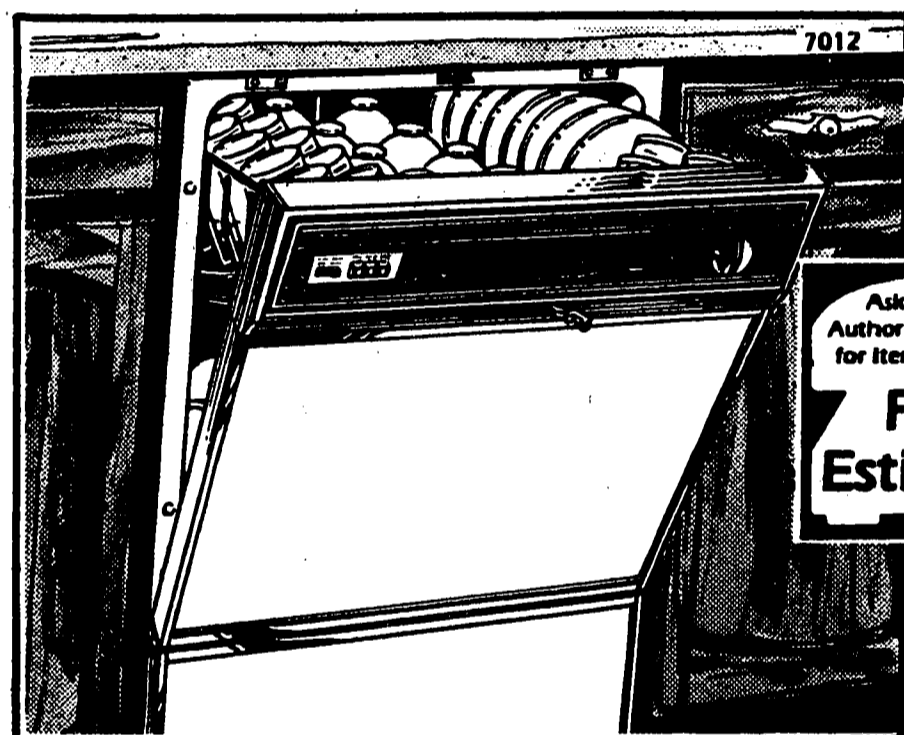

Dishwasher with 2-level wash
Water Miser cycle, Power Miser control to help save energy. Pot/pan cycle for heavily soiled loads. Reversible color panels for choice of 5 colors.
\$379.95 portable . . . **319.95** White
Sale ends Aug. 28

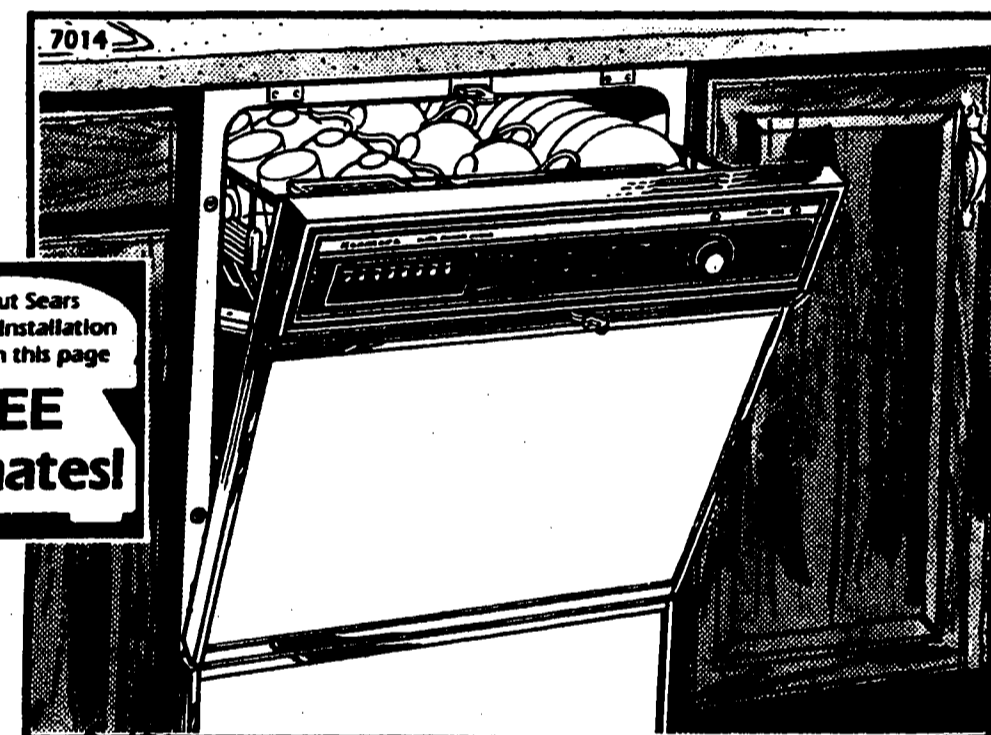

Dishwasher with 3-level wash
Water Miser cycle, Power Miser control. Pot/pan cycle. Rinse and Hold cycle, Sani-Temp control. Reversible color panels for choice of 5 colors.
\$489.95 portable, **389.95** Colors extra
Sale ends Aug. 21

Ask about Sears Authorized Installation for items on this page
FREE Estimates!

FREE gallon bleach with detergent



Reg. \$13.99 24-lb. Box
219⁹⁸
FOR
Clorox bleach with the purchase of a 24-lb. box of Sears heavy-duty detergent. Removes more soil than the nation's leading detergent.
Sale ends Aug. 28

FREE dispenser with 1-gallon liquid detergent
Reg. \$8.49 **6⁹⁹**

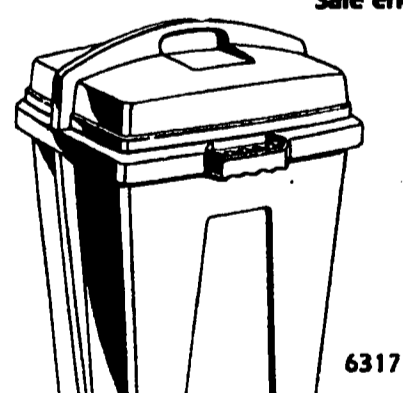

6317
FULL 6-Year Warranty
If, within 6 years from the date of purchase, this Perma-nex® plastic container or lid cracks or breaks, we will, upon return, replace it free of charge.
SAVE \$5 on Perma-nex can with 6-yr. warranty
32-gal. can resists cracking. Domed lid.
Reg. \$19.99 **14⁹⁹**

6125R **SAVE \$1**
Sears Best trash bags 35 (26-gal.), 25 (33-gal.), or 15 (45-gal.).
Reg. \$6.99 **5⁹⁹**
Sale ends Aug. 28

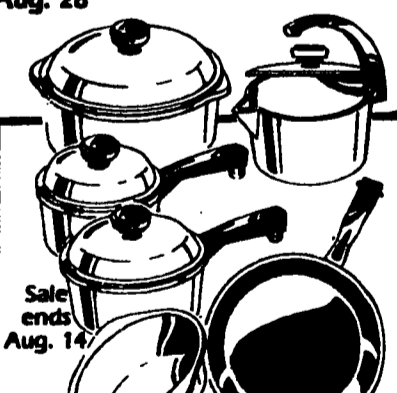

50111
SAVE \$60
on 9-pc. cast aluminum cookware set
SilverStone® interior for stick-resistant cooking.
Reg. sep. 1982 Fall General Cat. prices total \$160.95 **79⁹⁹**

10042 **SAVE \$32**
7-pc. stamped aluminum cookware set
SilverStone® interior, durable porcelain exterior.
Reg. sep. 1982 Fall General Cat. prices total \$82.95 **49⁹⁹**
Sale ends Aug. 14

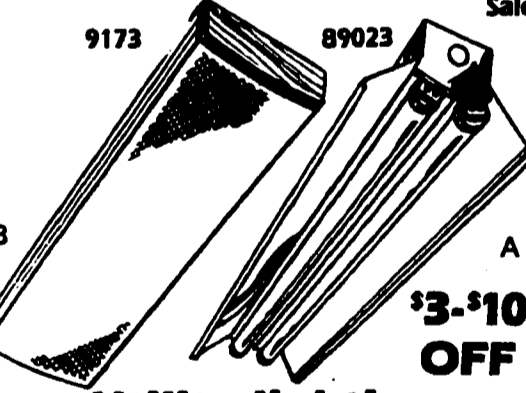

9173 89023
\$3-\$10 OFF
Utility lighting
A. \$4 OFF 48-in. work light With two 40-watt fluorescent bulbs, chain. Reg. \$18.99 **14⁹⁹**
B. fluorescent ceiling fixture Acrylic diffuser with wrap-around design. Two 60-watt bulbs included. \$36.99 24-in. wraparound. . . . **29.99**

49074-5 7799 57019 5926
100-ft. extension cord, reg. \$17.99 **11.99**
50-ft. extension cord with cord lock. . . . **8.99**
Trouble light, 20-ft. cord, reg. \$19.99 **15.99**
5933
Sale ends Aug. 14

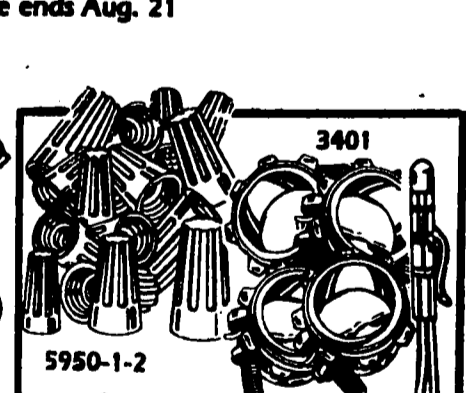

3401 5191
Your choice 79^c
Current tester, reg. \$1.49
Handy box, reg. \$1.19
Junction box, reg. \$1.09
Cable connectors, reg. \$1.19 pkg.
Wire connectors, reg. \$1.29 pkg.
Brown or ivory color duplex outlet, reg. 99^c
Brown or ivory color quiet switch, reg. 99^c

6007-8
Current tester, reg. \$1.49
Handy box, reg. \$1.19
Junction box, reg. \$1.09
Cable connectors, reg. \$1.19 pkg.
Wire connectors, reg. \$1.29 pkg.
Brown or ivory color duplex outlet, reg. 99^c
Brown or ivory color quiet switch, reg. 99^c

Each of these advertised items is readily available for sale as advertised.

Kenmore Power Miser™ 8 water heaters can save you \$288 in gas bills over an 8-year* period when compared with our standard water heaters

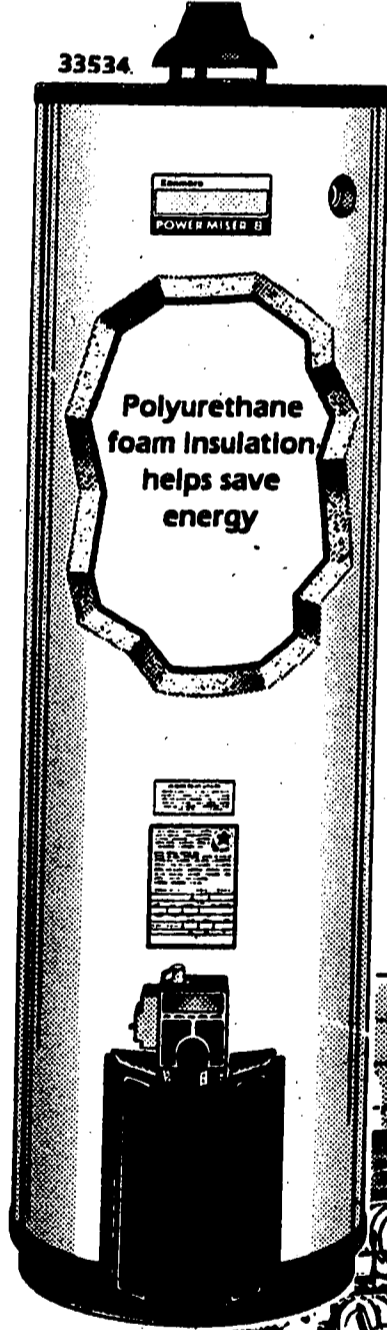

Most items on this page is also available at Brighton and Howell stores.

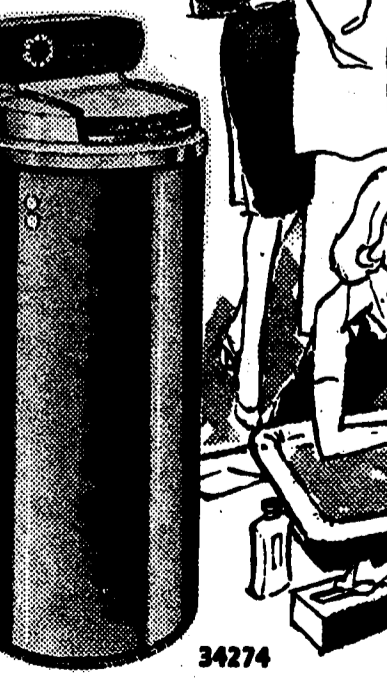

Ask about our FREE water analysis

SAVE \$30 199⁹⁹

30-gallon size
Regular \$229.99
Regular \$249.99 . . . 40-gal. size **219.99**
Regular \$279.99 . . . 50-gal. size **249.99**

NEED HOT WATER FAST?
Call Sears for 24-hour emergency installation (except Sundays and holidays) by our Authorized Installers. Or pick up your water heater and install it yourself. Installation extra.

*In accordance with U.S. Dept. of Energy Test Procedures, the operating cost was calculated on the basis of 64.3 gallons per day of hot water usage by a family of 4 with 90°F temp. rise, with gas rate of 42.6¢ per therm (U.S. government 1981 national average cost figures). Savings were calculated by subtracting the operating cost of our Power Miser™ 8 40-gal. gas model from the cost of operating our standard 40-gal. gas water heaters. Savings may be more or less depending on your hot water usage and local utility rates.

SAVE \$110-\$130 on Kenmore water softeners . . . CLOSEOUT

High-capacity, Regular \$459.99 **349⁹⁹**
Electronic, Reg. \$399.99 **469⁹⁹**
Enjoy all the advantages of softened water. Helps protect pipes and appliances from scale buildup. Use less soap, detergent.
Limited quantities

Sears

SAVE \$40 on Sears Best storm doors



Reg. \$239.99
199⁹⁹
32, 36x80-inch

- Plastic foam-filled aluminum frame and double wall
- Triple weatherstripped vinyl sweep helps seal out drafts
- Sears exclusive pushbutton key lock latch and deadbolt
- Interchangeable weatherstripped break-resistant tempered glass insert

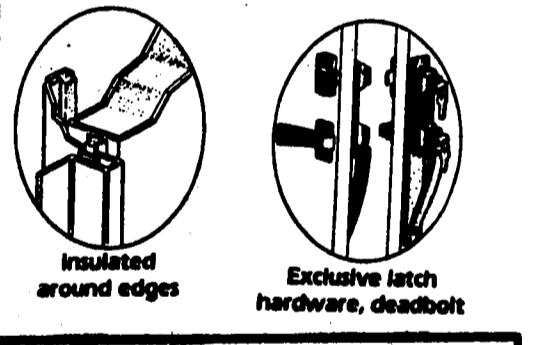

2317
15% OFF Installed guttering
Continuous seamless guttering custom installed on the spot.
Sale ends Aug. 14

25% OFF Installed shingles
Glass fiber shingles have Class A fire rating from UL.
Sale ends Aug. 14

Phone 800-462-8757 for FREE estimates

SAVE \$40 Sears garage door opener



CLOSEOUT, Was \$189.99
149⁹⁹
Limited quantities

With 1/2-HP motor, over 3,000 digital codes. Woodgrain look steel cover. Light delay system keeps light on 4 1/2-minutes. One transmitter.
340 OFF Opener with 1/2-HP motor, Reg. \$249.99 . . . 209.99
Sale ends Aug. 14

Sears

SAVE \$60 or \$100
on Sears Kenmore® dishwashers

Stainless steel hoods also on sale!

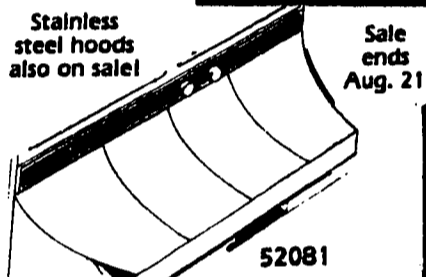

SAVE \$20

30-in. Kenmore range hood
200 CFM. Vented/ventless installation. White, colors.
Reg. \$109.95

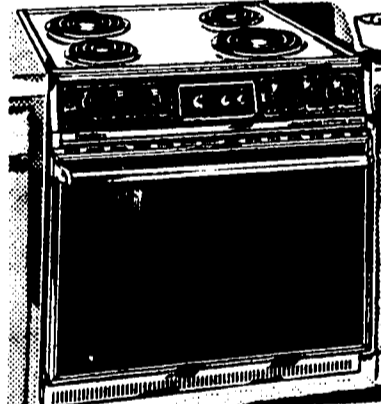

SAVE \$100
on Kenmore electric drop-in range
Automatic delay, start and off oven. 30-in.
Reg. \$569.95

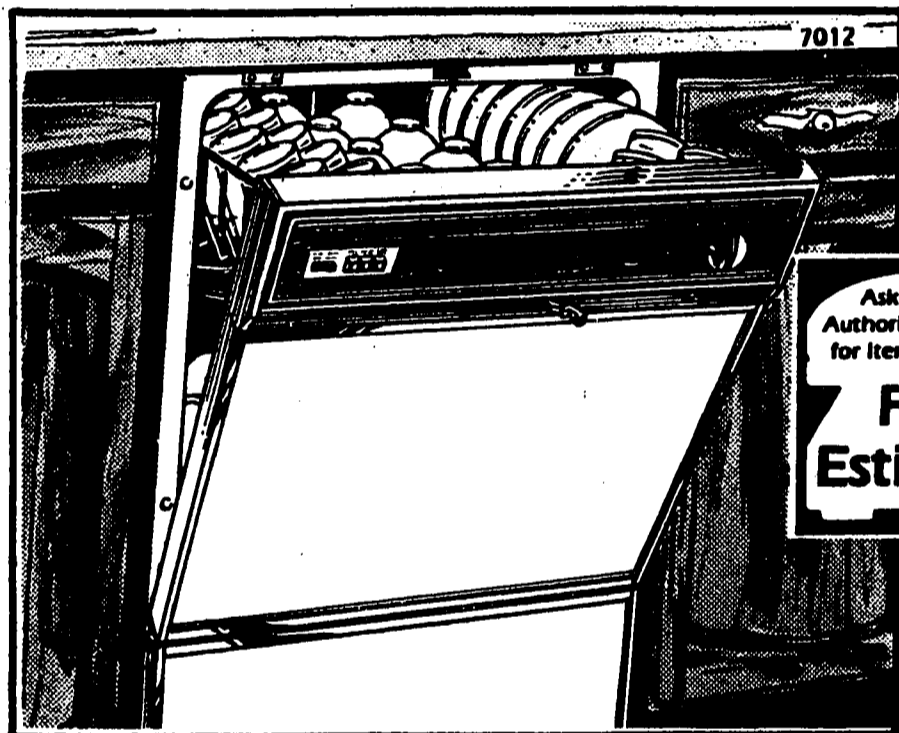

Dishwasher with 2-level wash

Water Miser cycle, Power Miser control to help save energy. Pot/pan cycle for heavily soiled loads. Reversible color panels for choice of 5 colors.
\$379.95 portable . . . 319.95 White

Reg. \$349.95
289⁹⁵

Sale ends Aug. 28

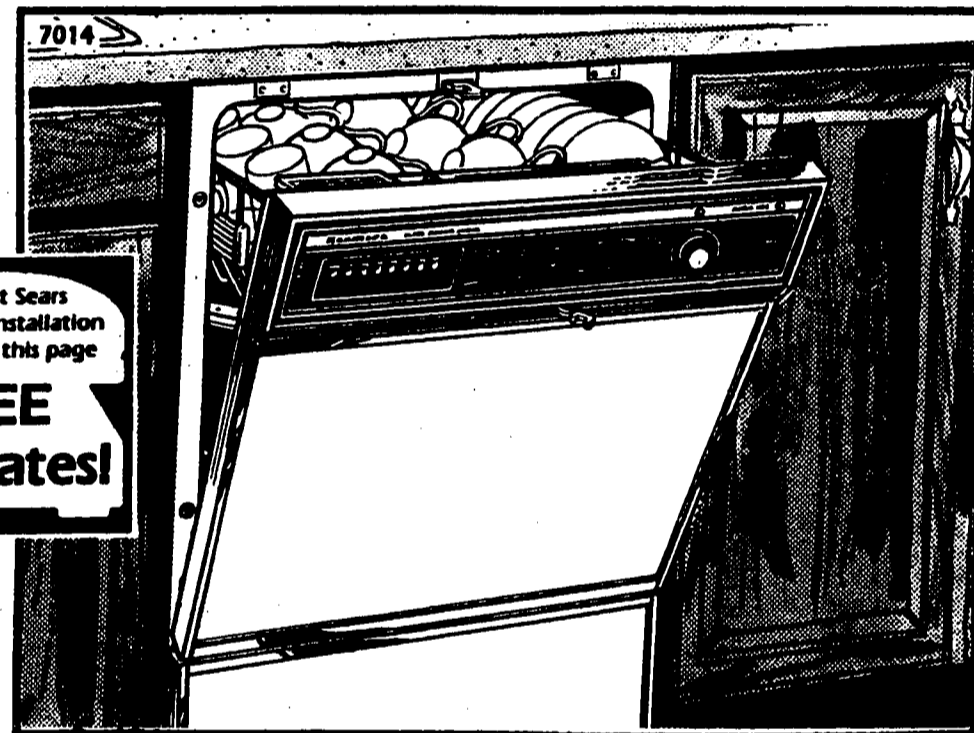

Dishwasher with 3-level wash

Water Miser cycle, Power Miser control. Pot/pan cycle. Rinse and Hold cycle, Sani-Temp control. Reversible color panels for choice of 5 colors.
\$489.95 portable, 389.95 Colors extra

Reg. \$449.95
349⁹⁵

Sale ends Aug. 21

Ask about Sears Authorized Installation for items on this page
FREE Estimates!

FREE gallon bleach with detergent



Reg. \$13.99
24-lb. Box
219⁹⁸
FOR
Clorox bleach with the purchase of Sears heavy-duty detergent. Removes more soil than the nation's leading detergent.
Sale ends Aug. 28



FREE dispenser with 1-gallon liquid detergent
Reg. \$8.49
6⁹⁹
Sale ends Aug. 28

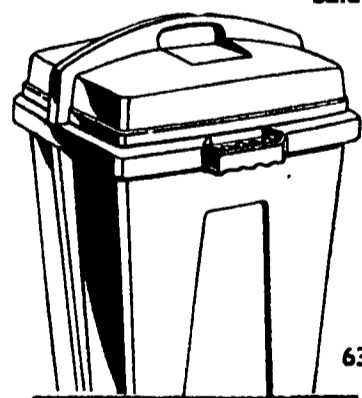

SAVE \$5 on Permanex® can with 6-yr. warranty
32-gal. can resists cracking. Domed lid.
Reg. \$19.99
14⁹⁹



SAVE \$1 Sears Best trash bags
35 (26-gal.), 25 (33-gal.), or 15 (45-gal.).
Reg. \$4.99
5⁹⁹
Sale ends Aug. 28



SAVE \$60 on 9-pc. cast aluminum cookware set
SilverStone® interior for stick-resistant cooking.
Reg. sep. 1982 Fall General Cat. prices total \$146.95
79⁹⁹



SAVE \$32 7-pc. stamped aluminum cookware set
SilverStone® interior; durable porcelain exterior.
Reg. sep. 1982 Fall General Cat. prices total \$82.96
49⁹⁹
Sale ends Aug. 14

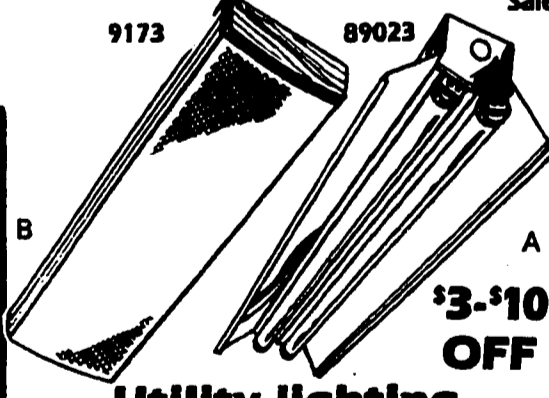

Utility lighting
A. \$4 OFF 48-in. work light
With two 40-watt fluorescent bulbs, chain. Reg. \$18.99
14⁹⁹
B. fluorescent ceiling fixture
Acrylic diffuser with wrap-around design. Two 60-watt bulbs included.
Reg. \$49.99
36⁹⁹
\$36.99 24-in. wraparound . . . 29.99

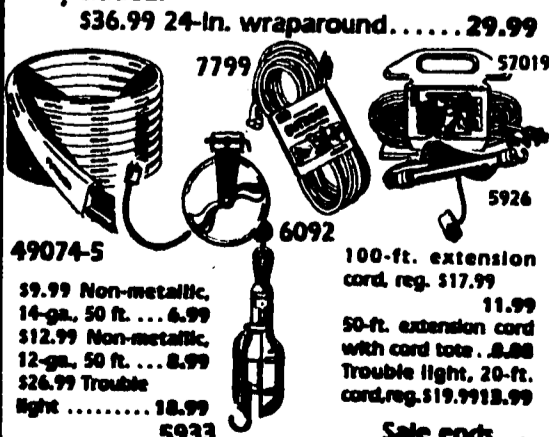

Your choice 79¢
Current tester, reg. \$1.49
Handy box, reg. \$1.19
Junction box, reg. \$1.09
Cable connectors, reg. \$1.19 pkg.
Wire connectors, reg. \$1.29 pkg.
Brown or ivory color duplex outlet, reg. 99¢
Brown or ivory color quiet switch, reg. 99¢

Each of these advertised items is readily available for sale as advertised.

Kenmore Power Miser™ 8 water heaters can save you \$288 in gas bills over an 8-year* period when compared with our standard water heaters

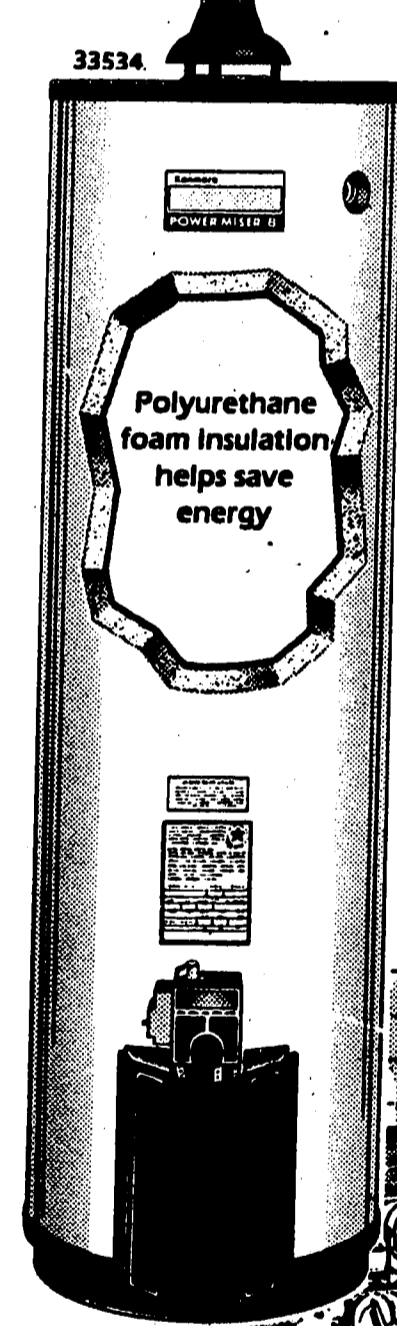

SAVE \$30
199⁹⁹

30-gallon size
Regular \$229.99
Regular \$249.99 . . . 40-gal. size 219.99
Regular \$279.99 . . . 50-gal. size 249.99

NEED HOT WATER FAST?
Call Sears for 24-hour emergency installation (except Sundays and holidays) by our Authorized Installers. Or pick up your water heater and install it yourself. Installation extra.

*In accordance with U.S. Dept. of Energy Test Procedures, the operating cost was calculated on the basis of 64.3 gallons per day of hot water usage by a family of 4 with 90°F. temp. rise, with gas rate of 42.6¢ per therm (U.S. government 1981 national average cost figures). Savings were calculated by subtracting the operating cost of our Power Miser™ 8 40-gal. gas model from the cost of operating our standard 40-gal. gas water heaters. Savings may be more or less depending on your hot water usage and local utility rates.

Most items on this page is also available at Brighton and Howell stores.



SAVE \$110-\$130
on Kenmore water softeners . . . CLOSEOUT

High-capacity, Regular \$459.99
349⁹⁹
Electronic, Reg. \$599.99
469⁹⁹

Enjoy all the advantages of softened water. Helps protect pipes and appliances from scale buildup. Use less soap, detergent.
Limited quantities

Ask about our FREE water analysis

Sears

SAVE \$40
on Sears Best storm doors



Reg. \$239.99

199⁹⁹

32, 36x80-Inch

- Plastic foam-filled aluminum frame and double wall
- Rovell™ kickpanel
- Triple weatherstripped vinyl sweep helps seal out drafts
- Sears exclusive pushbutton key lock latch and deadbolt
- Interchangeable weatherstripped break-resistant tempered glass insert

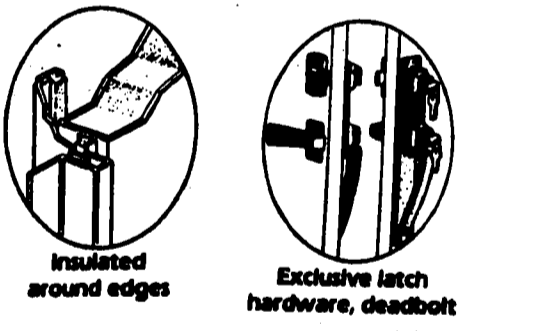

15% OFF Installed guttering

Continuous seamless guttering custom installed on the spot.
Sale ends Aug. 14

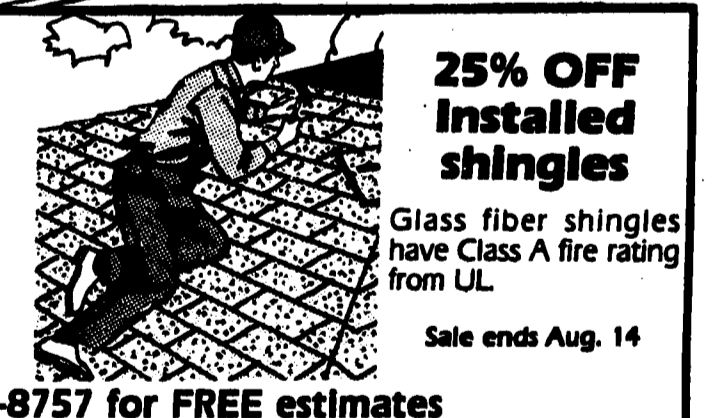

25% OFF Installed shingles

Glass fiber shingles have Class A fire rating from UL.
Sale ends Aug. 14

Phone 800-462-8757 for FREE estimates



SAVE \$40
Sears garage door opener

CLOSEOUT, Was \$189.99

149⁹⁹

Limited quantities

With 1/2-HP motor, over 3,000 digital codes. Woodgrain look steel cover. Light delay system keeps light on 4 1/2-minutes. One transmitter.

\$40 OFF Opener with 1/2-HP motor, Reg. \$249.99 . . . 209.99
Sale ends Aug. 14

Sears

CRAFTSMAN
WEEK
SALE

SAVE \$4-\$7

on these one-coat latex paints

17621

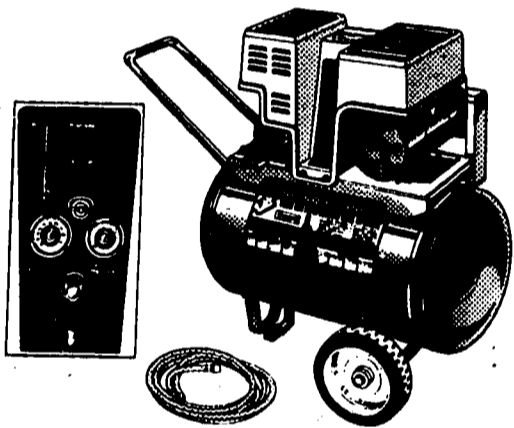

\$200 OFF 1-HP compressor

Craftsman, delivers 7.0 SCFM at 40 PSI, 100 PSI max. Has 12-gal. air tank, air hose. Safety-shrouded.

Regular \$499.99
299⁹⁹

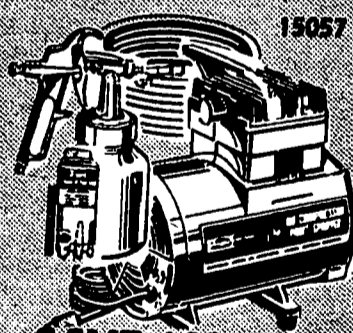

SAVE \$40
compressor kit
Craftsman 1/2-HP compressor, spray gun.

Reg. \$179.99
139⁹⁹

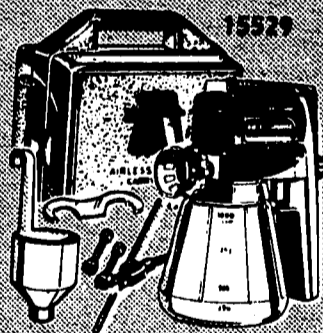

SAVE \$90
sprayer kit
Sears Best airless sprayer, accessories.

Reg. \$190.99
99⁹⁹

Limited Quantity

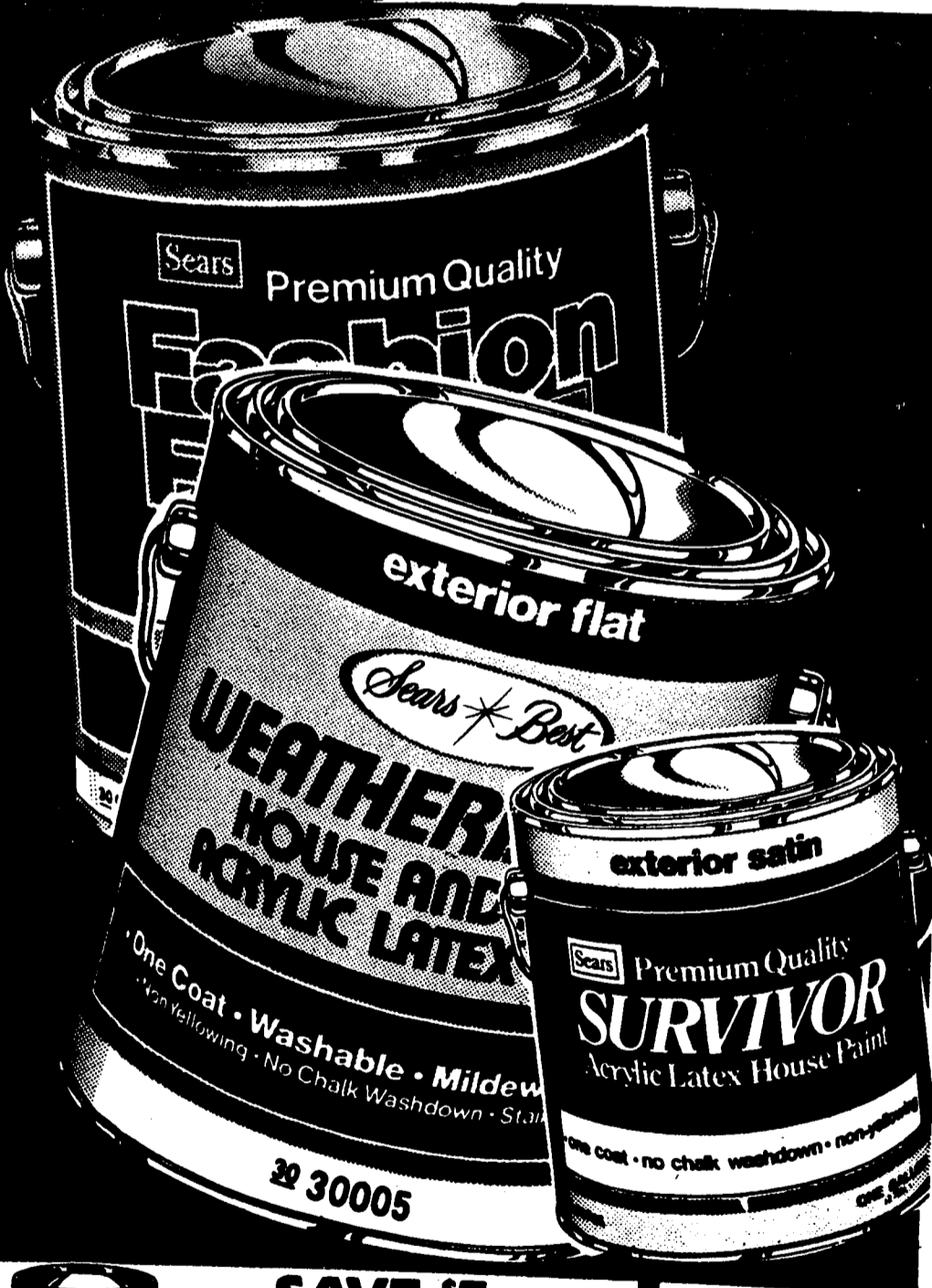

\$4 OFF
Fashion
Interior latex
Flat or ceiling white

Regular \$13.99
9⁹⁹ gallon

Sears premium quality interior latex gives you washable one-coat coverage in 23 colors.
\$14.99 Semi gloss. **10.99** gal.
Sale ends Aug. 15

\$7 OFF
Weatherbeater®
exterior latex

Flat finish
Regular \$16.99
9⁹⁹ gallon

Sears Best exterior latex is stain and mildew resistant. One-coat coverage in 50 colors.
\$17.99 Weatherbeater low luster satin **10.99** gal.
Sale ends Sept. 4

\$6 OFF Survivor satin
Washable one-coat coverage in 30 non-yellowing colors.

Regular \$14.99
8⁹⁹ gallon

Sale ends Aug. 15

For one-coat results, all Sears one-coat paints must be applied as directed

\$3-\$7 OFF all in-stock wallcoverings



Regular \$10.98
7⁹⁸

Regular \$16.98
11⁹⁸

Regular \$20.98
13⁹⁸

Wallcovering not at Grosse Pointe, Highland Park, Ann Arbor, Novi, Southfield.

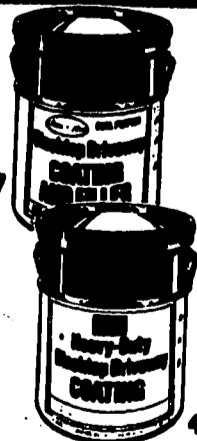

SAVE \$5
driveway coating
Sears best coating for asphalt driveways.

Reg. \$16.99
11⁹⁹ 5-gal.

SAVE \$5
driveway coating
Heavy-duty rubberized coating.

Reg. \$14.99
9⁹⁹ 5-gal.



SAVE \$3
oil-base floor paint

Washable one-coat coverage in 6 durable non-yellowing colors.

Reg. \$15.99
12⁹⁹ gal.

Sale ends Aug. 14

Paint also available at Brighton and Howell stores

55005

You can count on **Sears**
SEARS, ROEBUCK AND CO.

Satisfaction Guaranteed or Your Money Back

Open 9:30 am to 9 pm Monday through Saturday; Sundays 12 noon to 5 pm

• Macomb Mall 293-8000
• Oakland Mall 585-1000
• Southfield 559-8000

• Pontiac Mall 681-9900
• Livonia Mall 476-6000
• Lincoln Park 383-7000

• Twelve Oaks/Novi 348-9200
• Fairlane/Dearborn 336-0100
• Briarwood/Ann Arbor 769-8900

• Lakeside/Sterling Heights 247-1500

Open 9:30 am to 6:30 pm (Mon. thru Fri.)

Sat. 9:30 to 6 — Closed Sunday

• Highland Park 868-1300

Open 9:30 am to 9 pm (Mon. thru Fri.)

Sat. 9:30 to 6 — Sun. 12 to 5

• Grosse Pointe Farms 884-6000

Pull out for 8 pages of great **VALUES**

Sears

Home Appliance

CARNIVAL OF VALUES

Reduced prices shown in this section in effect until Aug. 28.

\$50 OFF permanent press Kenmore® pair

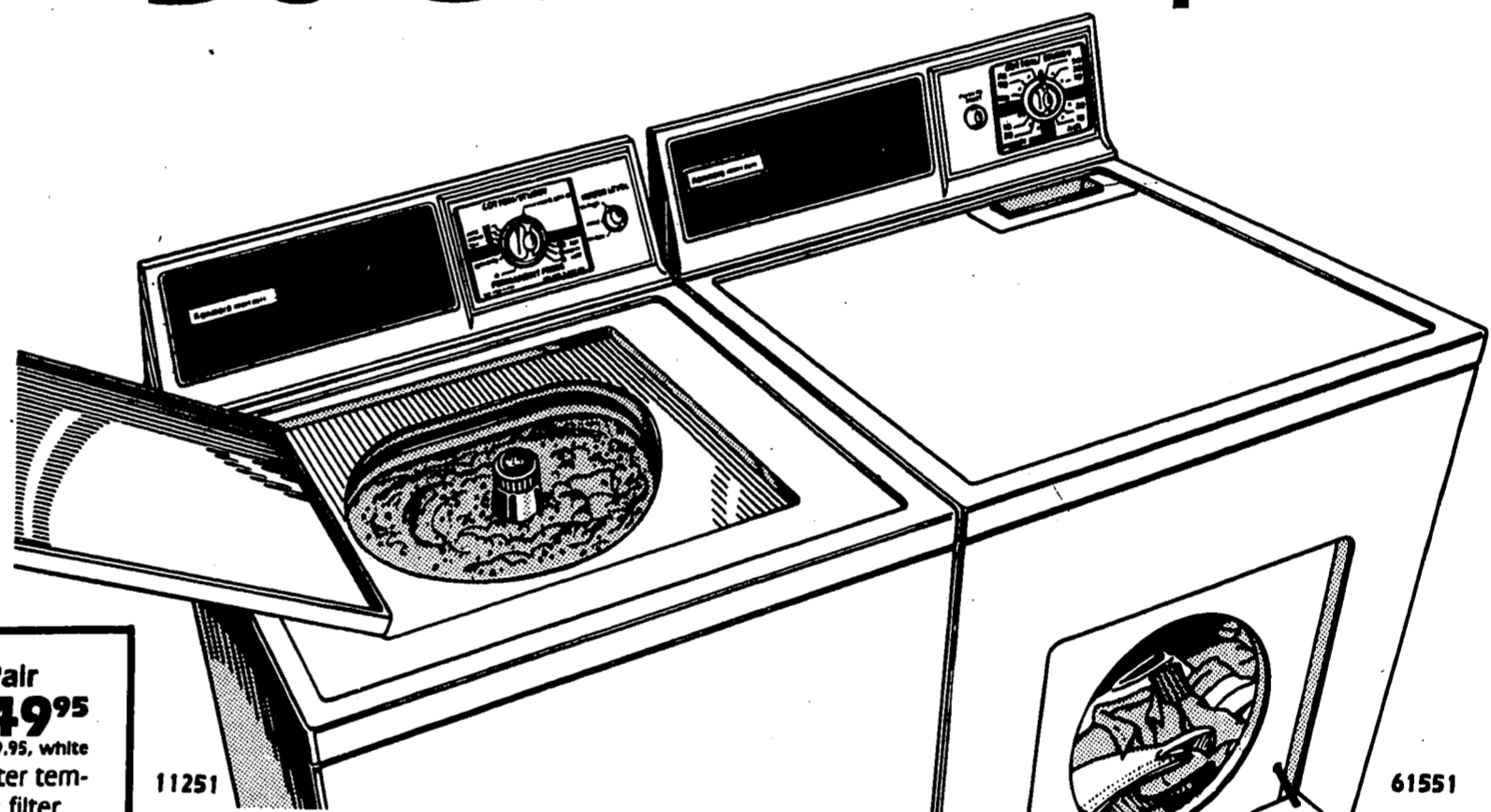

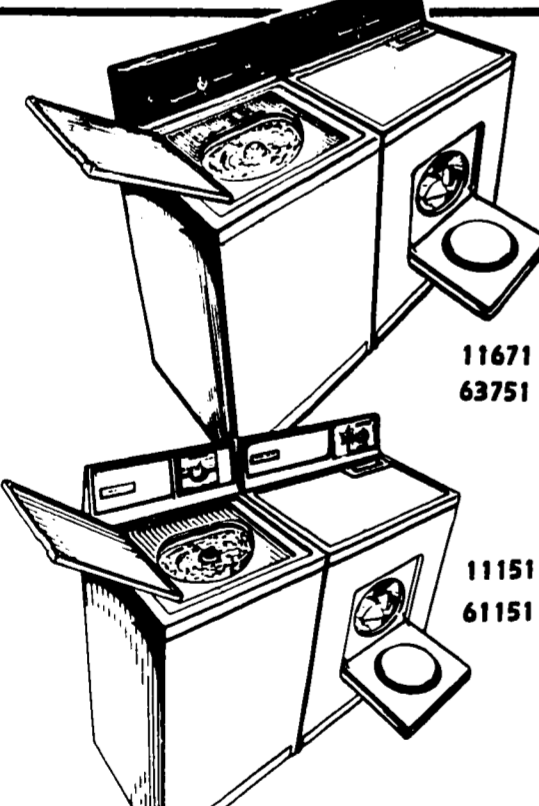

\$80 OFF Pair

2-speed washer **349⁹⁵**
Reg. \$379.95, white
5 cycles, 3 water temperatures. Lint filter.

Electric dryer **269⁹⁵**
Reg. \$319.95, white
Automatic termination. Touch-up cycle.
Regular \$359.95 gas dryer**309.95**
PAIR PRICE Reg. \$699.90 ... NOW **619.90**

11671
63751

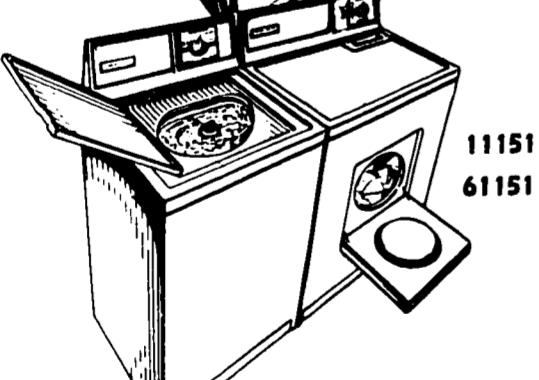

Heavy-duty pair

Automatic washer **\$279**
White only
3 water temperatures.

Electric dryer **\$219**
White only
2 cycles, including air.
Gas dryer**\$259**

11151
61151

11251 61551

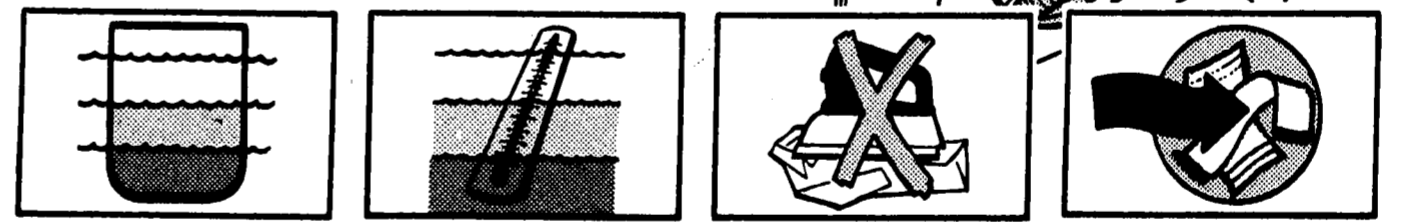

3 water levels — match water to size of load. Helps save energy. 3 wash/rinse temperature combinations for proper fabric care. Permanent press cycle for easy fabric care ... neat, fresh look. "Air-only" option for gentle fluff-drying of special items.

2-cycle washer 289⁹⁵ Reg. \$319.95, white only
3-cycle dryer 229⁹⁵ Reg. \$249.95, white only, electric
PAIR PRICE, Reg. \$569.90... Now **519.90** \$289.95 Pilot-free gas dryer, NOW **269.95**

Dryers require connector not included in prices shown.

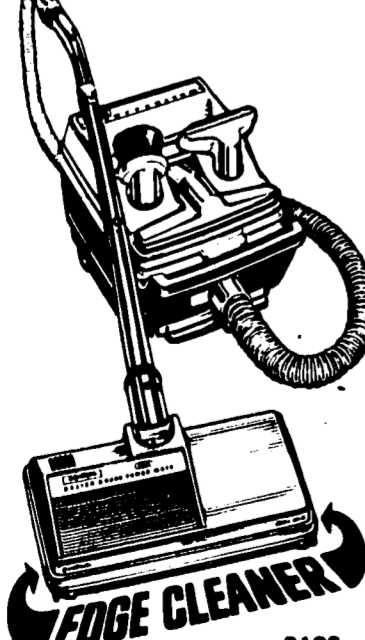

SAVE \$30
Power-Mate® vac
Strong suction and a beater bar brush for deep down cleaning. Edge cleaning gets close to walls.
Reg. \$179.95 **149⁹⁵**



CANISTER VAC #2130 at our everyday low price **\$49**



SAVE \$20
Powerful upright vac
Strong twin fan suction and beater bar for thorough cleaning of embedded dirt. Edge cleaning. 4 heights.
Reg. \$109.95 **89⁹⁵**

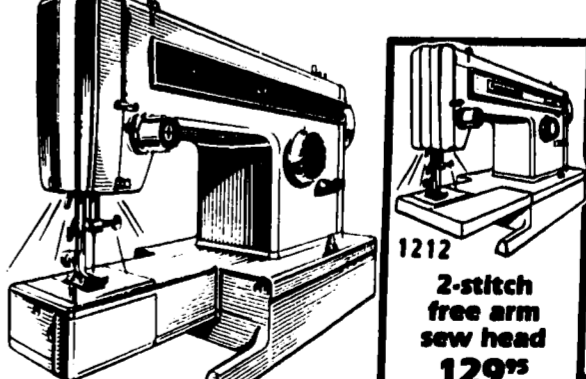

1212
2-stitch free arm sew head 129⁹⁵



1340
\$40 OFF 6-stitch sew head
4 utility and 2 stretch stitches. Built-in buttonholer. Ultra-Stitch provides great looking stretch stitches and buttonholes. Free-arm easily converts to flat-bed. Reg. \$199.95 **159⁹⁵**

Appliances also available at Brighton and Howell

Each of these advertised items is readily available for sale as advertised.

Ask about Sears credit plans.

Sears



62731

Home Appliance
CARNIVAL OF VALUES

Sale prices end Aug. 28

\$110 OFF

this 17.0 cu. ft. refrigerator-freezer

Reg. \$669.95
559⁹⁵

White Frostless... 12.24 cu. ft. fresh food section, 4.75 cu. ft. freezer. Nice 'N Fresh pan and crisper. On rollers. Ice maker kit available, priced extra. Colors extra

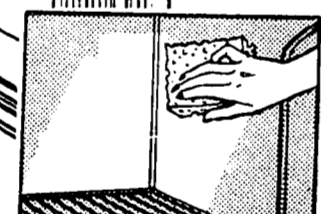

Porcelain-on-steel interior is durable, rust-resistant, easy to clean.

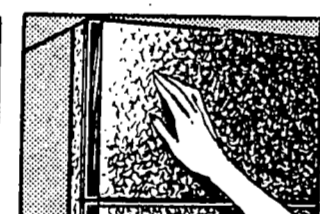

Textured steel finish doors help hide fingerprints and smudges.



61151

\$120 OFF

19.0 cu. ft. refrigerator, 6.34 cu. ft. freezer.

Reg. \$819.95 **699.95**

White Colors extra



61431

\$429⁹⁵

14.3 cu. ft. refrigerator, 3.90 cu. ft. freezer.

White only.

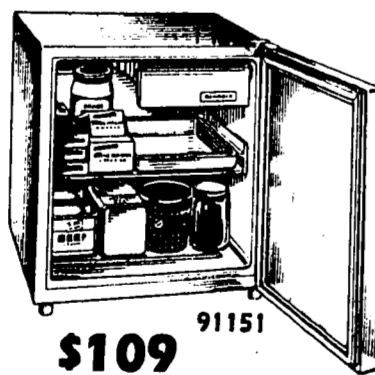

91151

\$109

1.7 cu. ft. refrigerator, 0.16 cu. ft. freezer.

White only.

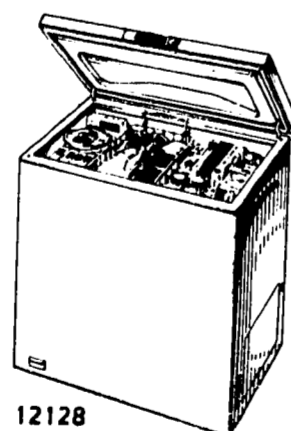

12128

\$50 OFF

chest freezer, 12.0 cu. ft. capacity.

Power signal light. Reg. \$379.95 **\$329.95**

White. 13.0 cu. ft., **\$399.95**

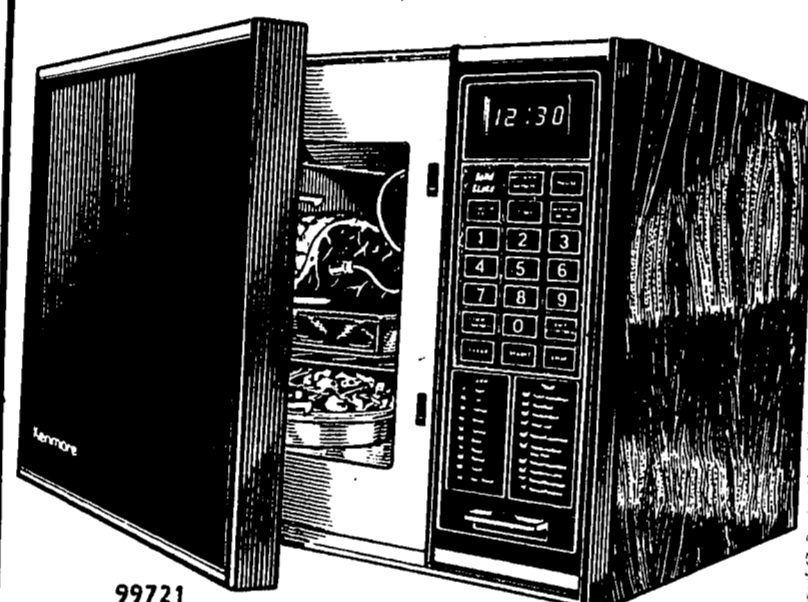

99721

SAVE \$130 on microwave oven with 2-stage memory

Memory lets you defrost and roast or use any 2 functions automatically. Probe.

399⁹⁵

Reg. \$529.95

Microwave oven

Spacious 1.4 cu. ft. oven. Timer.

299⁹⁵

VALUE! Microwave

0.5 cu. ft. oven.

\$199



99321

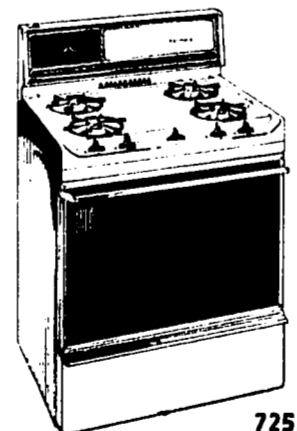

72521

SAVE \$100 on 30-in. gas or electric range

Your choice

Reg. \$499.95

Gas has pilot-free ignition. Electric has automatic oven. Clock. White. Both have continuous-cleaning oven, cleans spatters at normal baking temperatures.

399⁹⁵

Colors extra

Ranges require connector, extra.

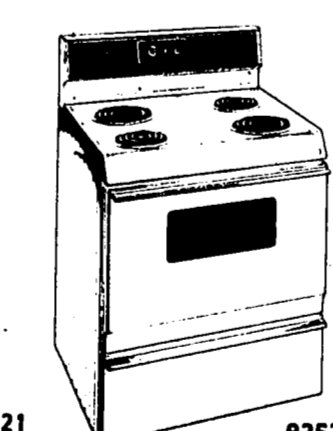

92521

\$90 OFF

this color TV with electronic tuner

Big, 19-in. diag. meas. picture. Automatic One-Button Color, Super Chromix® picture tube for vivid color.

Reg. \$489.95

399⁹⁵

BetaVision is designed to expand opportunities for your personal in-home TV viewing and not for any usage which might violate the copyright laws.

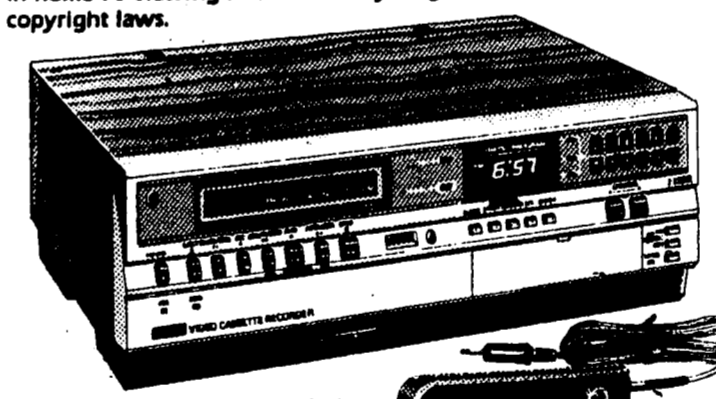

5312

\$100 OFF BetaVision 3-day video cassette recorder

Up to 5 hrs. per tape. Electronic tuner. Remote pause/still control for editing.

Reg. \$699.95

599⁹⁵

A special purchase, though not reduced, is an exceptional value.

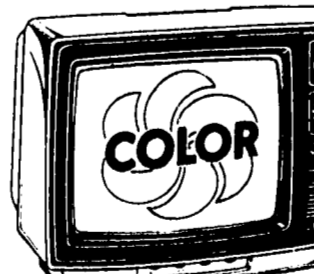

4025

Special purchase color TV

12-in. diag. meas. picture. Solid-state chassis. White quantities last

269⁹⁵

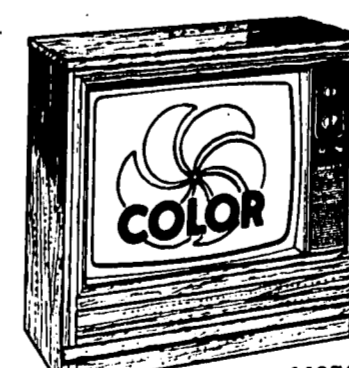

44051

BIG-SCREEN console TV

25-in. diag. meas. picture. Solid-state chassis.

\$499



LX SERIES

\$200 OFF mini-stereo

Amp, AM/FM tuner, cassette deck.

Reg. \$299.95

299⁹⁵



91946

\$100 OFF compact stereo

Cassette play/record, 8-track play, AM/FM.

Reg. \$279.95

179⁹⁵

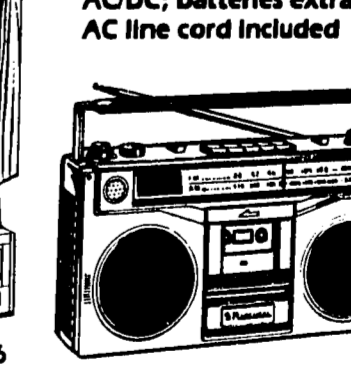

2193

\$20 OFF portable stereo

Cassette play/record, AM/FM stereo radio.

Reg. \$99.95

79⁹⁵

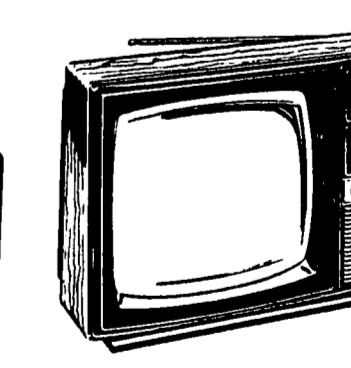

1995

\$20 OFF black/white TV

12-in. diag. meas. picture. Solid state chassis.

Reg. \$99.95

79⁹⁵

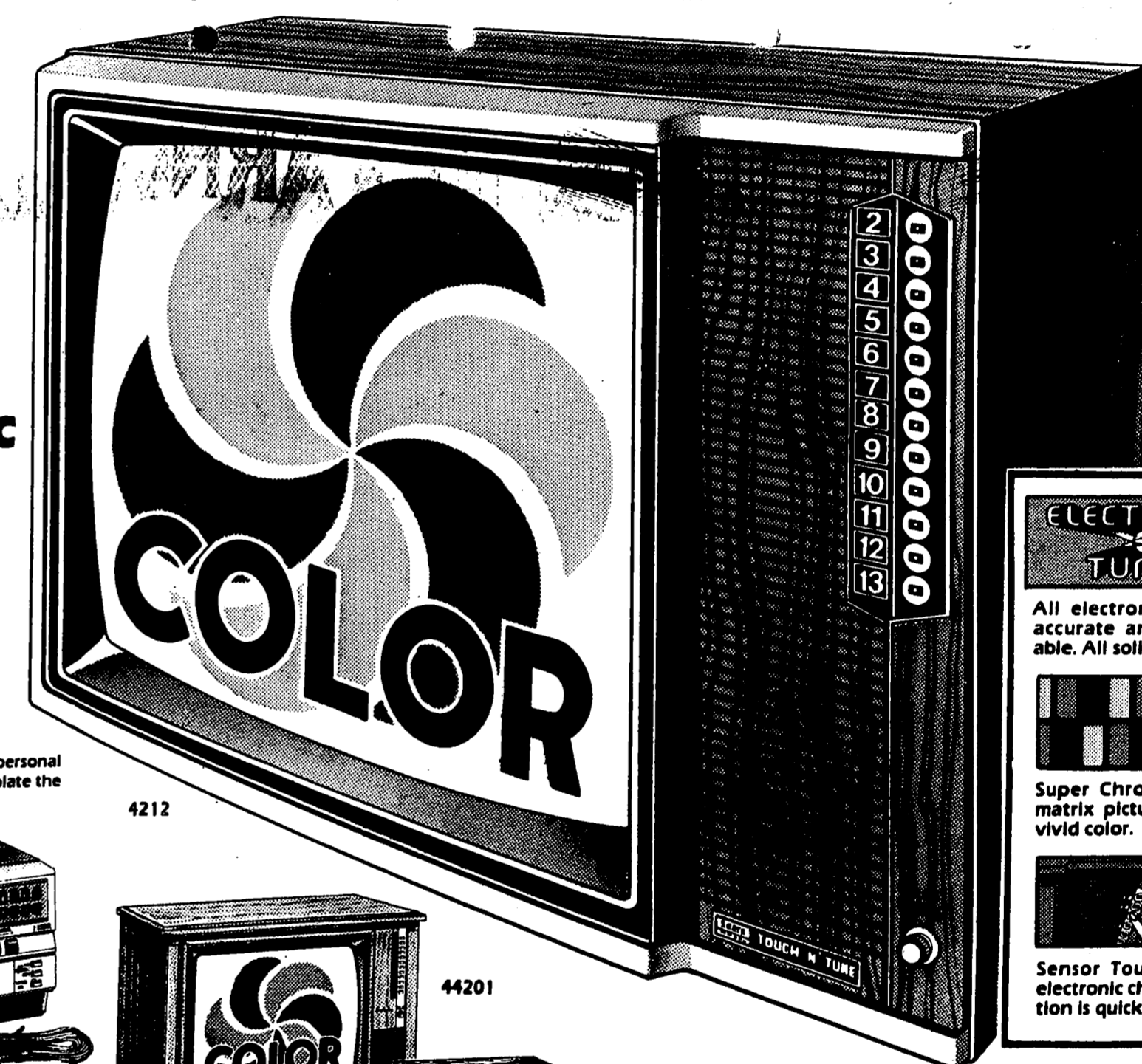

4212

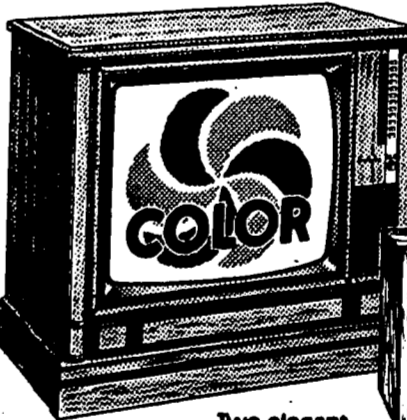

Two elegant cabinet styles

44201



44221

\$100 OFF console color TV with Touch n' Tune selection

25-in. diag. meas. picture. Reliable electronic tuner, One-Button Color.

Reg. \$699.95

599⁹⁵ each

ELECTRONIC TUNER

All electronic tuner is accurate and dependable. All solid-state.

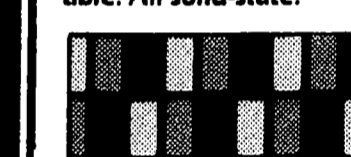

Super Chromix® black matrix picture tube for vivid color.



Sensor Touch reliable electronic channel selection is quick, silent.

End-of-season air conditioner SALE

Take advantage of big closeout savings on single and multi-room Kenmore units. Now with summer ending these units are priced to clear fast! Hurry while quantities last!

Appliances also available at Brighton and Howell

Each of these advertised items is readily available for sale as advertised.

Protect your appliance investment with a Maintenance agreement from Sears

- Annual maintenance check-up
- Prompt service follows you nationwide
- Tomorrow's service at today's prices
- Trained Sears Service technicians

Sears Service

STERLING HEIGHTS . . . 939-1900
LIVONIA . . . 425-9110
PONTIAC . . . 333-7123

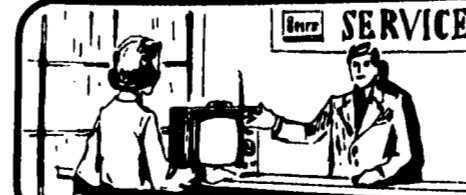

Sears WHILE-YOU-WAIT* Service Centers OPEN 9 To 5:30 Mon. thru Sat.

Pontiac, Mi.
481 N. Saginaw St.
(North of Wide Track)
333-7123

Sterling Heights, Mi.
34650 Mound Rd.
(South of 16 Mile)
938-1900

Livonia, Mi.
11850 Sears Ave.
(North of Plymouth Rd
West of Mackabell)
425-9110

* For professional repair service, bring your "carry-in" merchandise to a Sears Service Center
* Most repairs completed same day by trained technicians, provided that needed parts are in stock.



**SAVE \$50-\$70
on selected
Bonnet pieces**

Reg. \$149.99
to \$169.99 **9988**

YOUR CHOICE

- Twin size canopy bed with rails, canopy frame
- Single dresser
- Large hutch
- Student desk
- Storage chest

Bonnet and its French Provincial styling will delight anyone! Delicate gold color detailing.

Other matching pieces also on sale
\$169.99 Corner desk 149.88
\$169.99 Poudre 149.88
\$99.99 Small mirror 89.88
\$99.99 Nightstand 89.88
\$99.99 Chair 89.88

Furniture Department
(not at Grosse Pointe)
Sale ends Aug. 28

Use SearsCharge credit plan

**SAVE \$120-\$170
on bedding sets**

Available by the piece for...

Reg. 149.99. Twin Innerspring, polyurethane foam mattress or box spring **8988**

Sears Luxury bedding
189.99 Full mattress or box spring 129.88

Available by the piece for...
Reg. \$189.99. Twin Innerspring, Serofoam polymeric mattress or box spring **11988**

Sears-O-Pedic® Supreme
229.99 Full mattress or box spring 169.88
\$394.99 Twin longster set 259.88
Queen, king size sets also on sale

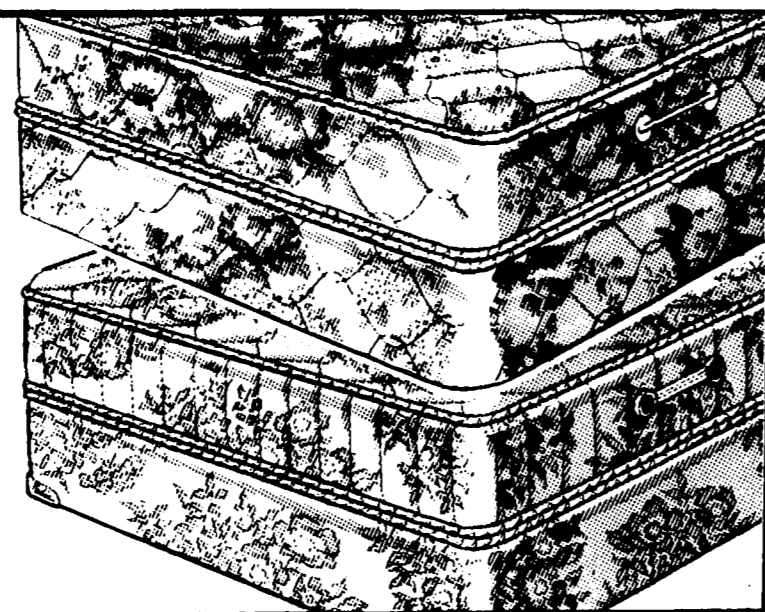

**SAVE 15%-35% sq. yd.
Our Touch Collection**

"Touch" carpets are made of long wearing sculptured nylon pile. Choose from many multicolors. Regular 9.99 to 26.99.

6⁹⁹-16⁹⁹
sq. yd.

Our Footlights Collection of level loop nylon pile. Reg. 9.99-12.99
..... 5.99-7.99 sq. yd.

Sale ends August 21
Carpeting Department (not at Grosse Pointe)

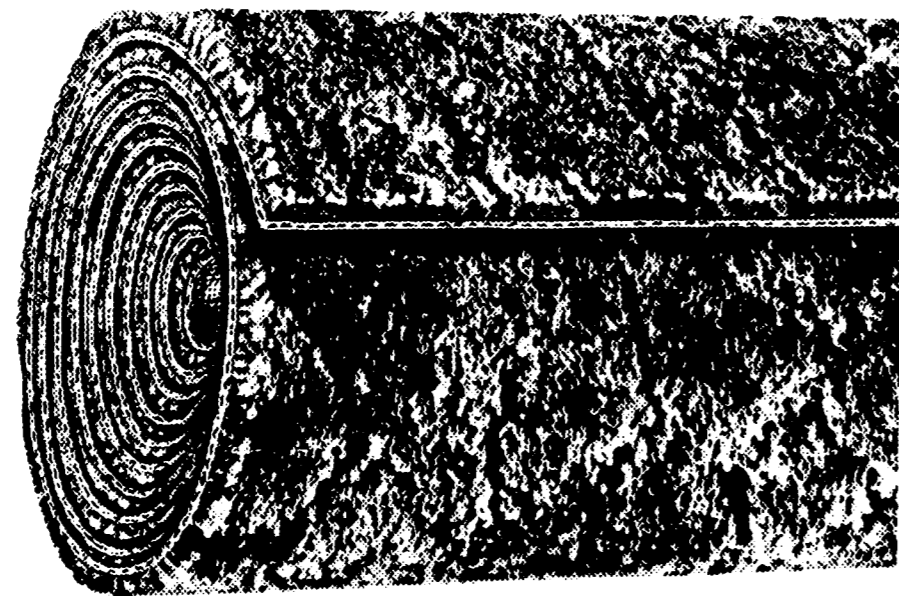

Sears

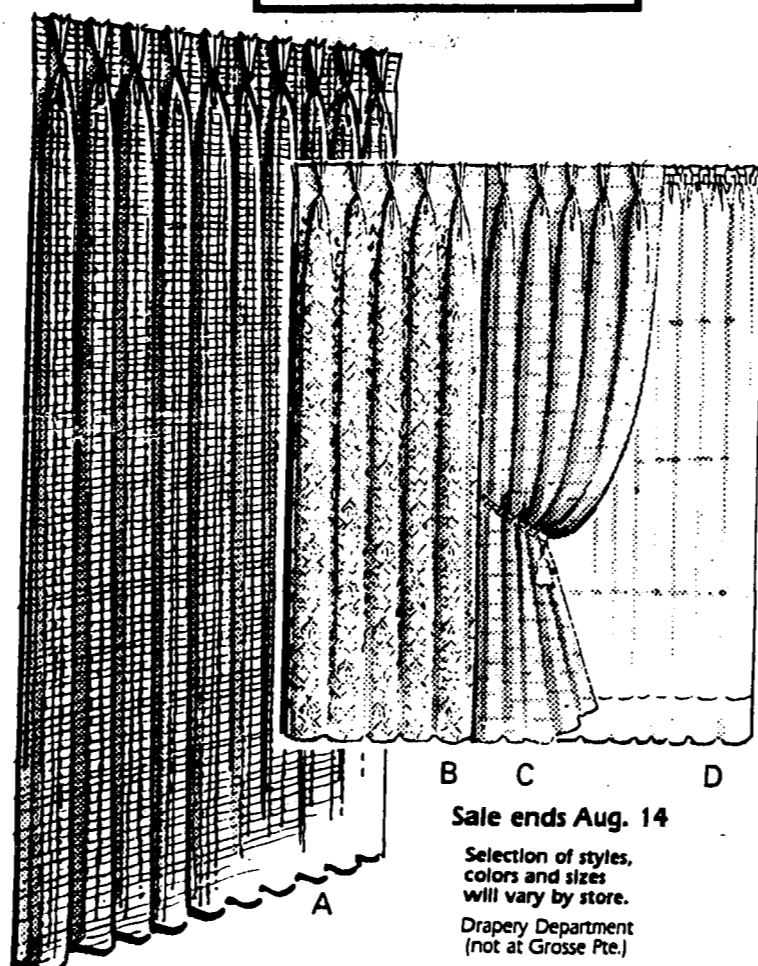

Sale ends Aug. 14
Selection of styles, colors and sizes will vary by store.
Draperies Department (not at Grosse Pte.)

**SAVE 15%-25% on selected
readymade draperies, panels**

A. Chico Openweave lined drapery. Reg. 33.99 **24⁹⁹**
48x84 in., pr.

B. Petit Plume jacquard weave drapery. Reg. \$20.99. **14⁹⁹**
50x84 in., pr.

C. Regal antique satin of rayon, acetate. Reg. \$30.99 **22⁹⁹**
48x84 in., pr.

D. Royal Jewel panel of polyester ninon. Reg. \$5.49 **4²⁹**
ea.
40x84 in.

Regency traverse rod fits windows 30-52 inches. Reg. 21.99 **18.49**

A wide assortment of readymade drapery sizes and colors are in stock, or readily available through special order.

**SAVE 25% on over 500
selected custom fabrics
30%-40% OFF
selected custom blinds**

Also:
25% OFF custom bedspreads, custom shades, custom shutters.

Call Sears Custom Studio and let us call on you. We have a free 68-page booklet for you, full of new ideas to help you decorate one window, one room, or your entire house.

Call toll-free 1-800-462-0866
(Call any time — 24 hours)



Sears

**\$2-\$3 OFF
jeans and shirts from
our Budget Shop**

Plaid shirts in easy-care polyester and cotton. Shirrtail bottom. Sizes 10-18.
Reg. \$7.99 **5⁹⁹** ea.

Prewashed navy denim jeans. Cotton, or polyester, cotton, rayon. 8 to 20.
Reg. \$10.99-\$12.99 **7⁹⁹ to 9⁹⁹**



\$7.99 Sweatshirts.
Stripes, solid colors. **6⁴⁹** ea.

Sale prices end August 14
Fashion Apparel (not at Grosse Pointe)

**\$9-\$13
OFF**

**Dresses and
jacket dresses
breeze thru fall**

A fresh mix of colors and textures to take you thru fall. Dresses and jacket dresses with soft tops and crisp poplin skirts and jackets. Tops of spun polyester; skirts and jackets of polyester and cotton poplin. Misses 6-18. Reg. \$39-\$43 ea.

29⁹⁹

In our Dress Department
Ask about Sears
credit plans

1/2 PRICE Every Frame in Stock
IN THE OPTICAL DEPARTMENT AT SEARS
Offer ends August 28



Sears 2-quart Pitcher

*Apply for a SearsCharge account and receive one of these (Nostalgic, MSU, U of M or Notre Dame) 2-qt. pitchers absolutely FREE at Sears.

Visit your nearest Metropolitan Detroit Area Sears Store, including Pontiac, Ann Arbor

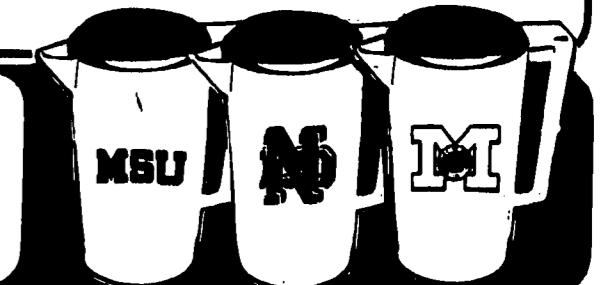

For Every Occasion . . . Give Flowers by Sears

Fresh Flowers delivered most anywhere. Order from your nearest Sears store . . .



584-7500

• Lincoln Park • Twelve Oaks
• Livonia • Fairlane • Southfield

585-0780

• Oakland • Macomb • Lakeside
• Highland Park • Grosse Pointe
485-7920 • Ann Arbor (Briarwood Mall)

338-2592

• Oakland • Lakeside
• Pontiac • Southfield



SALE. Grooming aids for home and school

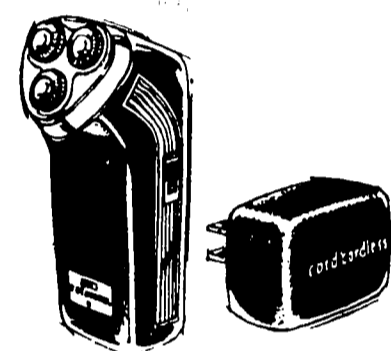

SAVE \$20
Rotomatic® II rechargeable razor
Use with or without cord. Rotary design has 36 cutting blades and 3 steel floating heads.
Reg. \$49.99 **29⁹⁹**

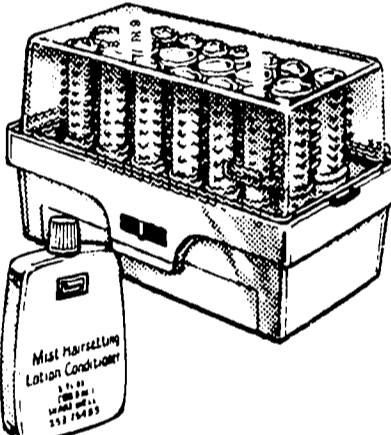

SAVE \$10
Three way compact hairsetter
Use dry, with mist or with lotion for styling versatility. Has front storage drawer. Plus, on/off switch.
Reg. \$29.99 **19⁹⁹**



SAVE \$7
1500 watt* blow dryer
Professional style. 7 accessories. Separate speed/heat, on/off switches.
Reg. \$19.99 **12⁹⁹**

*Manufacturer's rated wattage Health and Beauty Aids (not at Grosse Pointe)

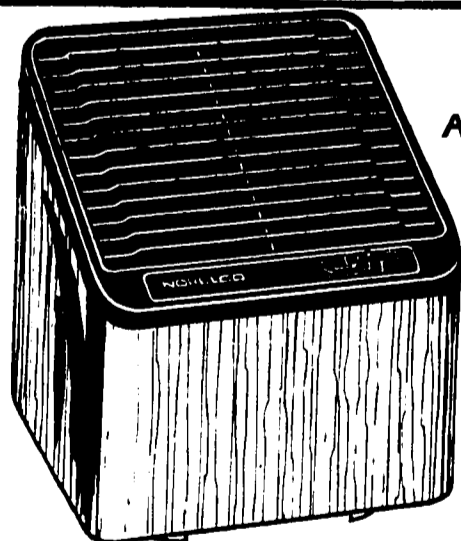

SAVE \$5 Two Speed Norelco Clean Air Machine

Helps clean and deodorize indoor air containing smoke, odors, pollen. Powerful, quiet 2-speed motor. High/low settings. With citrus scented filter.

Reg. 29.99 **24⁹⁹**

Citrus scented replacement filters last up to 3 months. Reg. 3.99 each. **3 for 9.99**

Sears

OUR BIGGEST DRESS SALE OF THE YEAR!



We show just two styles from our huge collection, all sale-priced for school! Little girls' woven dresses, sizes 4 to 6x. Reg. \$8.99-\$14.99... **6.69-10.99 ea.** Little girls' handsmocked Winnie-the-Pooh dresses, sizes 4 to 6x. Reg. \$13.99-\$17.99... **10.49-13.49 ea.** Big girls' woven back-to-school dresses, sizes 7 to 14. Reg. \$10.99-\$25.99... **8.19-19.49 ea.** Big girls' dresses at comparable savings in Pretty-Plus sizes at most larger Sears stores.

SAVE 25% on Kids' Toughskins® Jeans

Perma-Prest® jeans, in a tough blend of polyester, cotton and nylon. Save on assorted styles, regular or slim sizes. Here's a sample of the savings:
Boys' casual jeans or girls' slacks, sizes 3-6X... **7.49**
Boys' fashion jeans, sizes 8-12... **11.19**
Girls' casual jeans, sizes 7-14... **11.99**
Boys' fashion jeans, sizes 14-20... **12.69**
Boys' western jeans, sizes 8-12 and 14-20... **9.69-10.49**
25% OFF Tops to pair with their jeans. Sizes for big and little boys and girls.

Sale priced through August 21, except big boys' and girls' tops sale ends August 14 Kids' Apparel (not at Grosse Pointe)

20%-40% OFF Brass-Plated LAMPS

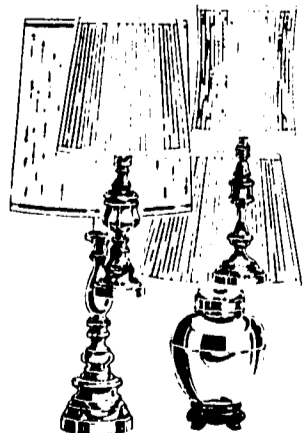

Reg. 54.99-119.99 **39⁹⁹-89⁹⁹**

Choice of styles to fit with most home decors.

Sale ends August 23

Lamp Department (not at Grosse Pointe, Southfield) Selection will vary by store

25%-30% OFF Our famous branded jeans
through Aug. 21

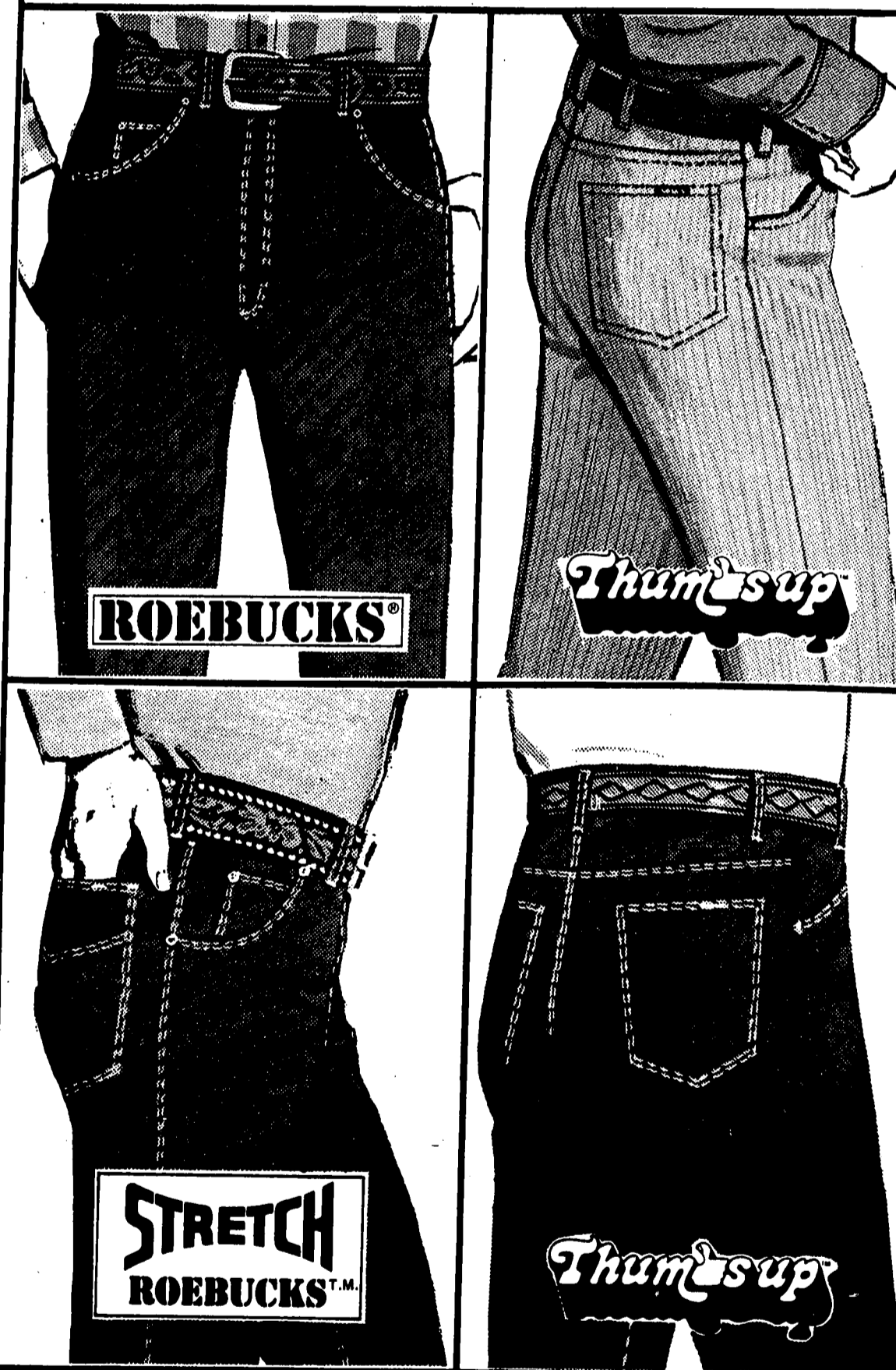

Roebucks® denims of 100% cotton. Regular and prewashed styles. Reg. \$16.99-\$17.99 **12⁶⁹-13⁴⁹**

Roebucks® stretch denims — a comfortable blend of cotton and 1½% Lycra® spandex. Reg. \$24 **17⁹⁹**

Thumbs-up™ corduroys of cotton and polyester. Reg. \$15-\$17 **10⁴⁹-11⁹⁹**

Thumbs-up™ denims — 100% cotton or cotton and Fortrel® polyester. Jeans and Mature fit. Reg. \$13-\$17 **8⁹⁹-12⁴⁹**

You can count on Sears for school supply VALUES

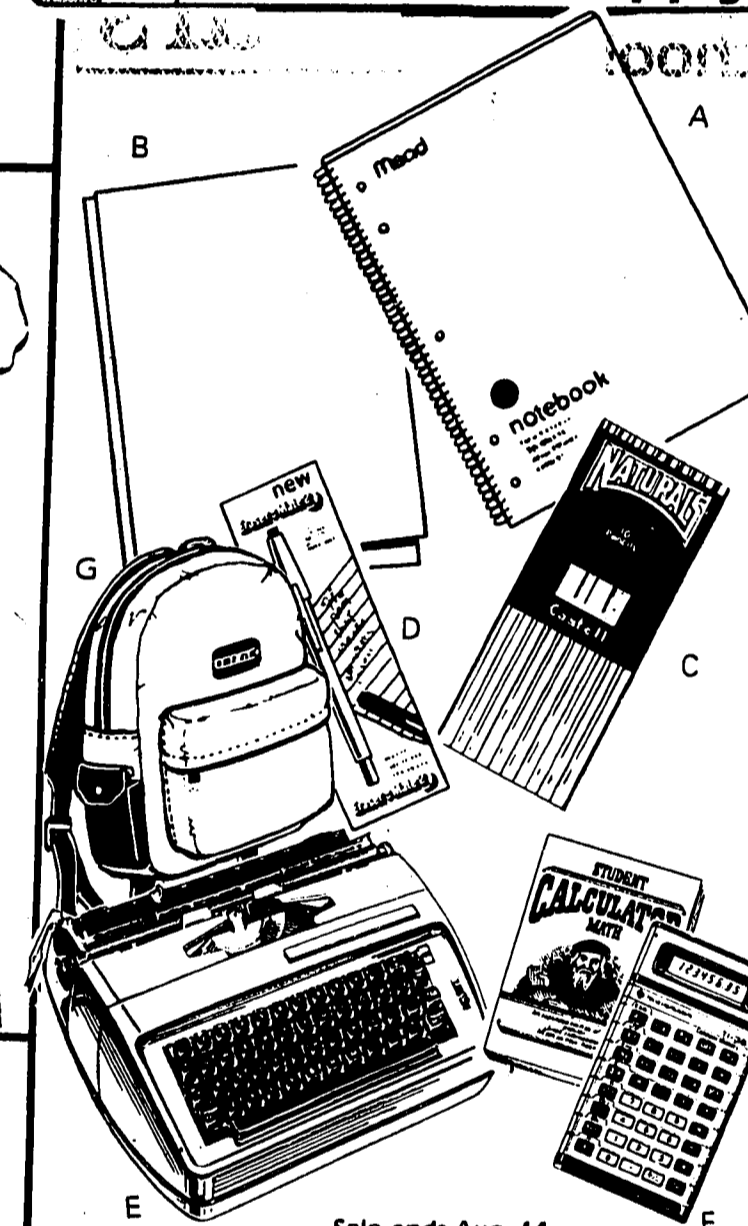

A. 70-page theme book, ass't. colors Reg. 69¢ **39¢**

B. Pockets/prongs portfolios, pk. of 3 Reg. 99¢ **59¢**

C. Ten pencils with eraser tops Reg. 99¢ **59¢**

D. Eraser Mate 2™ pen, eraseable ink Reg. 98¢ **59¢**

Limit 8 to a customer on each of above school supplies

E. Electric typewriter, with correction Reg. \$179.99 **159⁹⁹**

F. TI-35 calculator for scientific functions Math book incl. **17⁹⁹**

G. "The Bag" comes in 3 colors Reg. 11.99 **8⁹⁹**

Sears has on hand sufficient quantities to meet reasonable consumer demand. Sears reserves the right to limit quantities sold to commercial purchasers.

Sale ends Aug. 14 Office Supplies (not at Grosse Pointe)

25% OFF All Gym Sets in stock

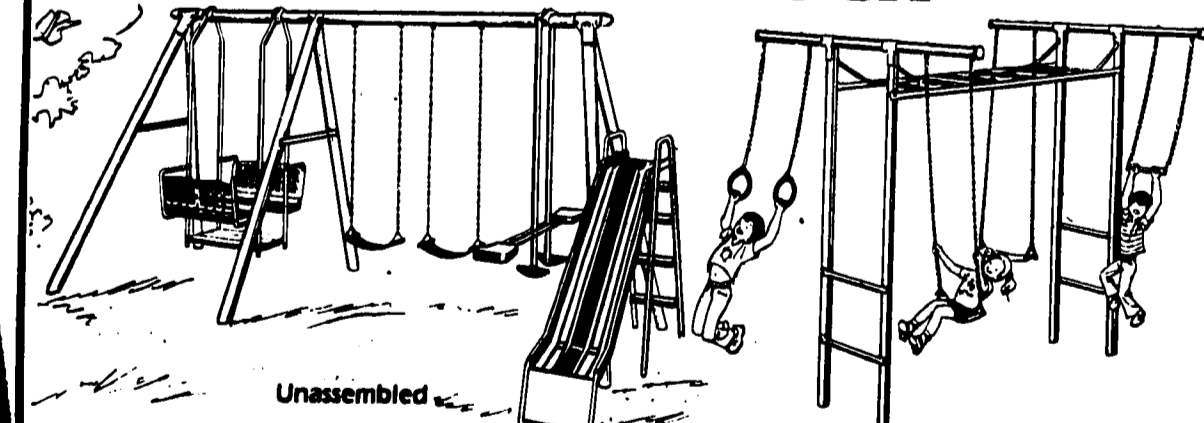

Unassembled \$50 OFF 6-leg gym set Reg. 199.99 **149⁹⁹**

2-in. tubular steel frame. Galvanized to resist rust. Specially coated 7-ft. slide. Toy Dept. (not at Grosse Pointe, Southfield)

\$27⁵⁰ OFF Big "T" gym Reg. 109.99 **82⁴⁹**

2 swings, gym ring, trapeze, leg climber, hand-over-hand bars.

Treats at sweet savings

- Maple Nut Goodies, Reg. 2.98 **2⁴⁸** lb.
- Spanish Peanuts, Reg. 2.98 sale ends Aug. 31 **1⁹⁸** lb.
- Delicious Pokies, Reg. 3.38 sale ends Aug. 14 **2⁴⁸** lb.

Candy and Nuts (not at Grosse Pointe, Southfield)

SOFT CONTACT LENSES Bausch & Lomb Soflens™

Price does not include eye examination or Lens Care Kit

\$59

In the Optical Department

Offer Ends August 28

SATISFACTION GUARANTEED OR YOUR MONEY BACK



Sea World

From Detroit, Mich. and Toledo, Ohio — Ohio Turnpike, Exit 12 — North on Rt. 8 to Rt. 82 East to Rt. 43 North

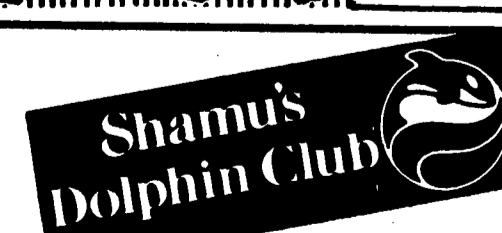

1982 Sea World

"ONE-PRICE" tickets available at Sears Customer Service Centers Adults (ages 12 and over) \$9.95 Children (ages 3 thru 11) \$8.50 Now open 9 a.m. daily thru Sept. 12

PULL OUT THIS SECTION FOR ADDITIONAL VALUES THROUGHOUT THE STORE!



Men's Cotton Underwear

Comfortable, absorbent, shrinkage controlled. Sizes S-M-L-XL. In packages of 3.

T, V-neck, A-shirts or briefs. Reg. 8.99 **6.69**
Heavyweight T-shirts. Reg. 10.99 **8.19**

Fashion Underwear. Low rise or bikini briefs, trim-cut boxers. S-M-L. Reg. 3.49 to 3.99 **2.59 to 2.99 each**



25% OFF Sears Best Slack Length Hosiery. Fits 10-13. Reg. 1.99 **1.49 pr.**

Sears

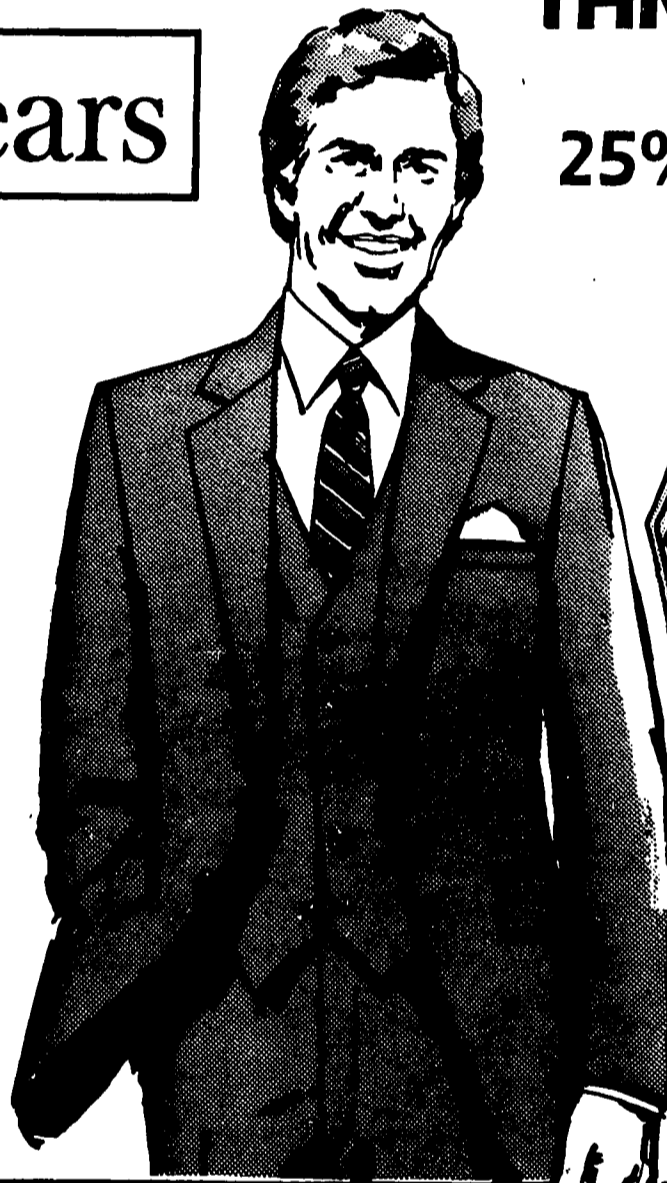

25%-30% OFF Classic Collection

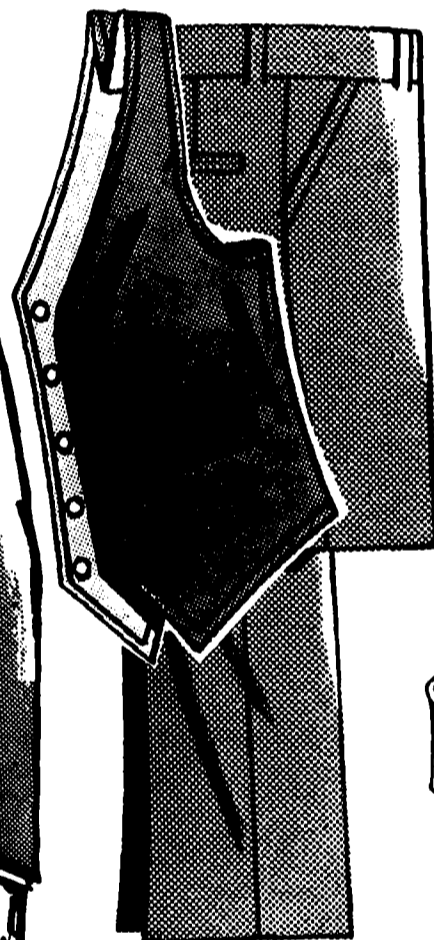

Men's separates in solid colors. Stretch woven polyester. Mix for traditional or sporty looks.

- \$65 Solid blazer **\$45**
- \$24 Reversible solid vest **\$18**
- \$26 Solid slacks **\$19**
- 25% OFF Classic Collection Pinstripes**
- \$70 Pinstripe coat **49.99**
- \$24 Pinstripe vest **\$18**
- \$27 Pinstripe slacks **\$20**

Sale ends Aug. 14



Casual Shirts

Thumbs Up® knit pullovers in collar and placket styling or stretch woven shirts in yarn-dyed plaids.

Polyester and cotton. Reg. 14.99-15.99 **11.99 ea.**

Short sleeve button front shirt, reg. 13.99 **9.99**

Sears Portrait Studio

BABIES • CHILDREN • ADULTS • FAMILY GROUPS



your baby

So different at three months, six... nine months, twelve. Remember the changes always with professional keepsake portraits taken regularly at Sears.

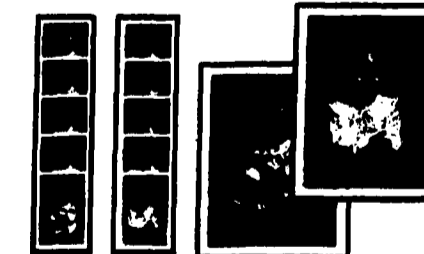

14 color portraits 10.95 total includes 95¢ deposit

No age limit. Photographic package includes two 8x10s, two 5x7s and 10 wallet size color portraits. 95¢ for each additional subject in portrait. Choice of backgrounds. Posing our selection.

Offer good for portraits taken thru Aug. 14

Most Detroit Area Sears Portrait Studios Open 10 a.m. to 8 p.m. Mon. thru Sat. (ALL Studios closed Sunday)
*Highland Park 10 to 6:30, Sat. 9:30 to 5:30 (not at Grosse Pointe)

INSTANT PASSPORT PHOTOS **Sears** COPY AND RESTORATION. Satisfaction guaranteed. Use your Sears charge card. SEARS, ROEBUCK AND CO. or your money back.

\$4 OFF

Women's Leather Upper SKIMMERS

Regular 19.99

15.99 pr.

Genuine full grain leather uppers. Cushioned heel seat for comfort. Flat heel measures about 1/2-in. high for easy walking. Choose from several styles, including styles with instep strap, string tie, or "penny" vamp overlay.

Sale ends August 21

The Shoe Place (not at Grosse Pointe)

Use SearsCharge credit plan



A special purchase, though not reduced, is an exceptional value.



Leather, split leather casuals

Women's Special Purchase **15.99**

1000 to sell

Sueded split leather moc toe oxford or smooth leather killtie. Soles of man made material. 5 1/2-9, 10B.

Men's Reg. 19.97 **16.99**

Tan sueded split leather athletic styled oxford. Flexible sole of man-made material. 7 1/2-11, 12D.

A Special Purchase, though not reduced, is an exceptional value.

Replace that missing side diamond up to 3 pt. stones

Reg. 59.95 **49.95**

Plus tax and setting
Jewelry Repair Department
Sale ends Aug. 14

PULL OUT THIS SECTION FOR ADDITIONAL VALUES THROUGHOUT THE STORE!

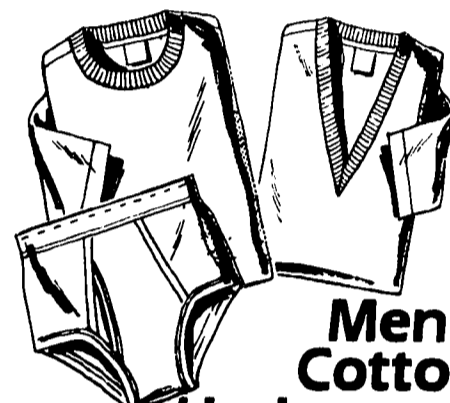

Men's Cotton Underwear

Comfortable, absorbent, shrinkage controlled. Sizes S-M-L-XL. In packages of 3.
 T, V-neck, A-shirts or briefs.
 Reg. 8.99 6.69
 Heavyweight T-shirts. Reg. 10.99 8.19
Fashion Underwear. Low rise or bikini briefs, trim-cut boxers. S-M-L.
 Reg. 3.49 to 3.99
 2.59 to 2.99 each

25% OFF Sears Best Stack Length Hosiery. Fits 10-13.
 Reg. 1.99 1.49 pr.

Sears



25%-30% OFF Classic Collection

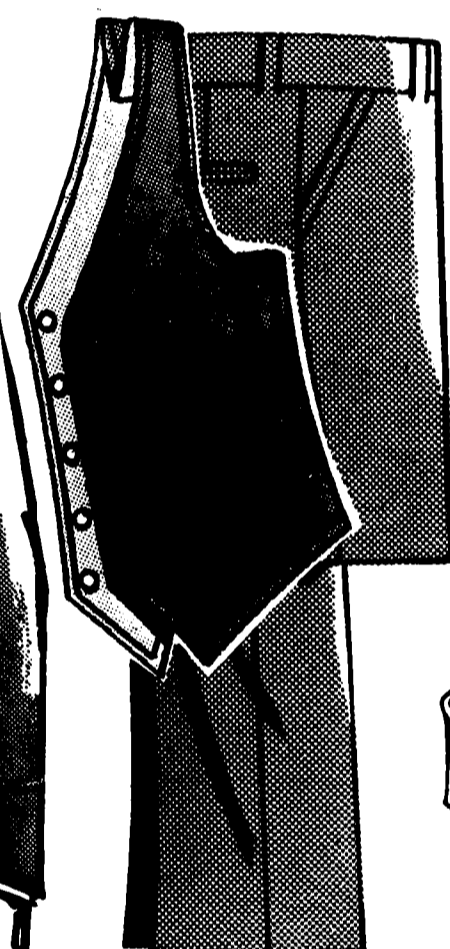

Men's separates in solid colors. Stretch woven polyester. Mix for traditional or sporty looks.

- \$65 Solid blazer \$45
- \$24 Reversible solid vest \$18
- \$26 Solid slacks \$19
- 25% OFF Classic Collection Pinstripes**
- \$70 Pinstripe coat 49.99
- \$24 Pinstripe vest \$18
- \$27 Pinstripe slacks \$20

Sale ends Aug. 14

Casual Shirts

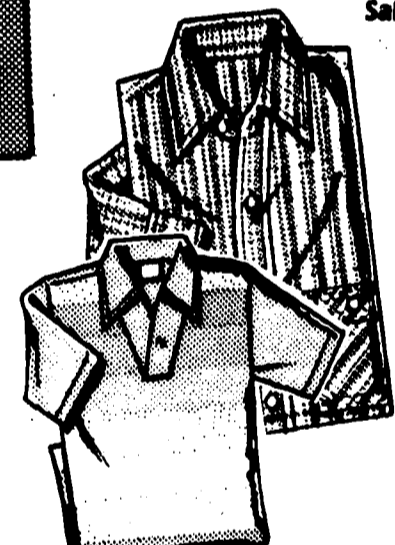

Thumbs Up® knit pullovers in collar and placket styling or stretch woven shirts in yarn-dyed plaids. Polyester and cotton.
 Reg. 14.99-15.99 11.99 ea.
Short sleeve button front shirt. reg. 13.99 9.99

Sears Portrait Studio



your baby

So different at three months, at nine months, twelve. Remember the changes always with professional keepsake portraits taken regularly at Sears.

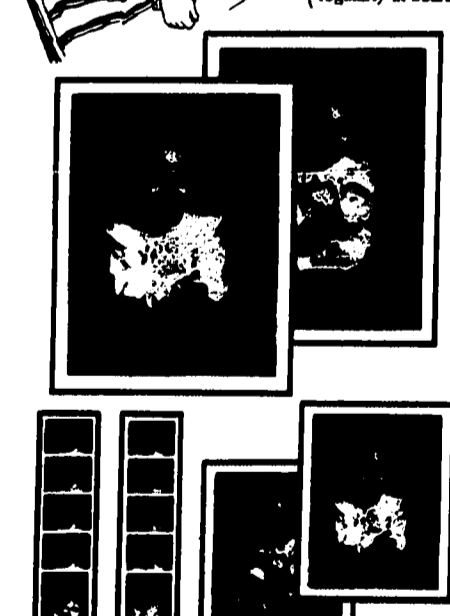

14 color portraits 10⁹⁵ total
 includes 95¢ deposit

No age limit. Photographic package includes two 8 1/2", two 5 1/2" and 10 wall-size color portraits. 95¢ for each additional subject in portrait. Choice of backgrounds. Pose our selection.

Offer good for portraits taken thru Aug. 14

Most Detroit Area Sears Portrait Studios Open 10 a.m. to 8 p.m. Mon. thru Sat. (ALL Studios closed Sunday)
 *Highland Park 10 to 6:30, Sat. 9:30 to 5:30 (not at Grosse Pointe)

INSTANT PASSPORT PHOTOS **Sears** COPY AND RESTORATION
 Use your Sears charge card. Make purchases with your Sears charge card.

\$4 OFF

Women's Leather Upper SKIMMERS

Regular 19.99

15⁹⁹ pr.

Genuine full grain leather uppers. Cushioned heel seat for comfort. Flat heel measures about 1/2-in. high for easy walking. Choose from several styles, including styles with instep strap, string tie, or "penny" vamp overlay.

Sale ends August 21

The Shoe Place (not at Grosse Pointe)

Use SearsCharge credit plan

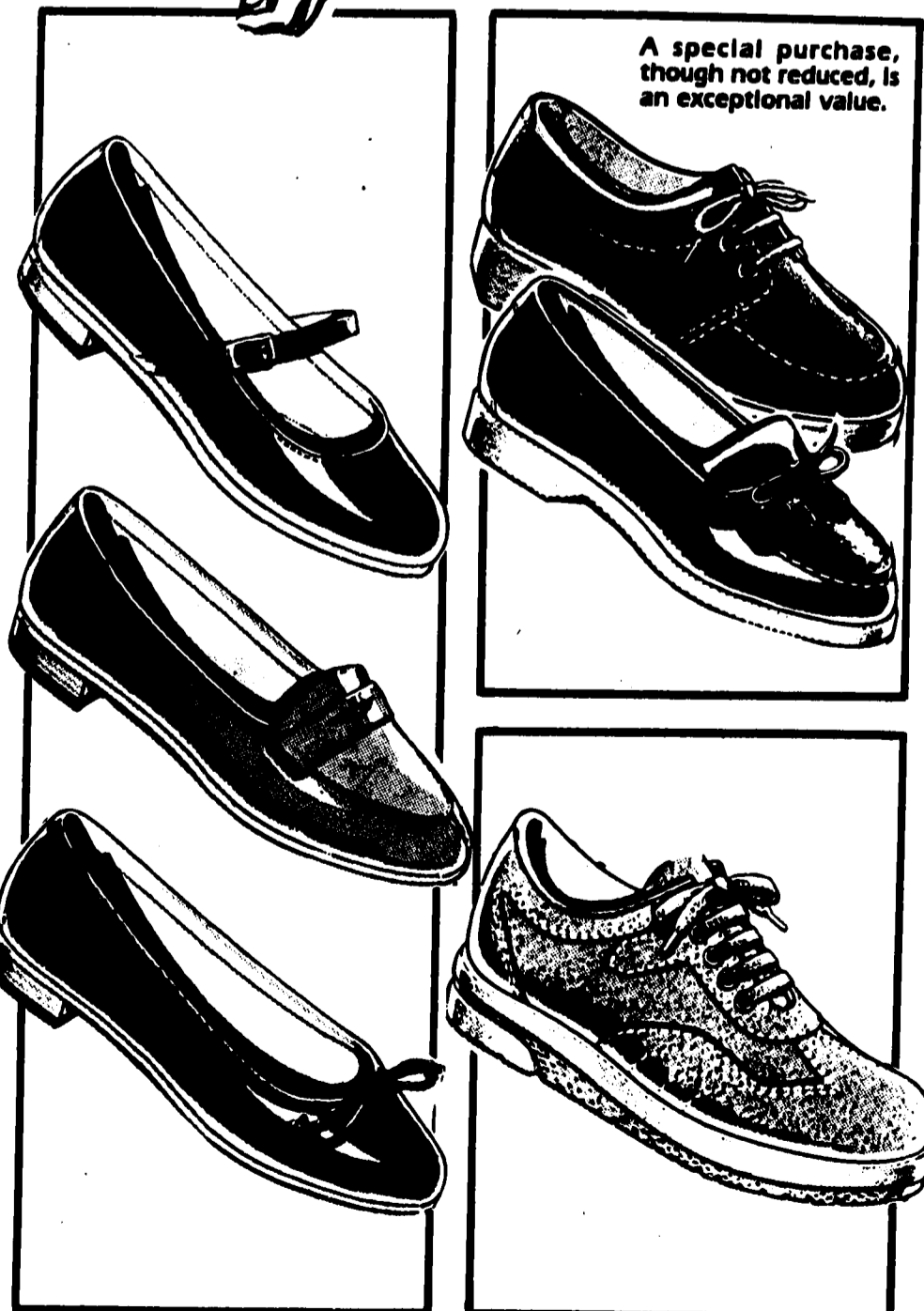

A special purchase, though not reduced, is an exceptional value.

Leather, split leather casuals

Women's Special Purchase **15⁹⁹**

1000 to sell
 Sueded split leather moc toe oxford or smooth leather kitten. Soles of man made material. 5 1/2-9, 10B.

Men's Reg. 19.97 **16⁹⁹**

Tan sueded split leather athletic styled oxford. Flexible sole of man-made material. 7 1/2-11, 12D.

A Special Purchase, though not reduced, is an exceptional value.

Replace that missing side diamond up to 3 pt. stones

Reg. 59.95 **49⁹⁵**

plus tax and setting
 Jewelry Repair Department
 Sale ends Aug. 14

Back To School

with the advantage of value
on schoolwear and more!



Hit the campus
with stylish
savings!

save 23%

9.97

Men's Short Sleeve Knit Shirt
For the "model" student! 75%
cotton/25% polyester. Fashion
knit collar has accent stripe.
Assorted sizes S-XL. Reg. 12.97

save 4.09

11.88

Men's Wrangler® Denim Jeans
It's a fit for every body! Wrinkle-
free 100% cotton No-Fault® denim
with Sanforset finish. Boot Cut
style in Slims or Regulars. 28-40
waist, 30-36 inseams. Reg. 15.97

save 27%

7.97

Men's Cowden Jeans A super
value on tough 100% cotton
jeans. And a price that's hard to
beat! 29-38 waist, 30-34 inseam.
Reg. 10.97



T-Shirt **4.97**

Brief 4.97
Hanes® Underwear for Men
100% cotton comfort is the
name of the game with this
soft white underwear. T-Shirt
in sizes S-XL; Brief in sizes
30-40.

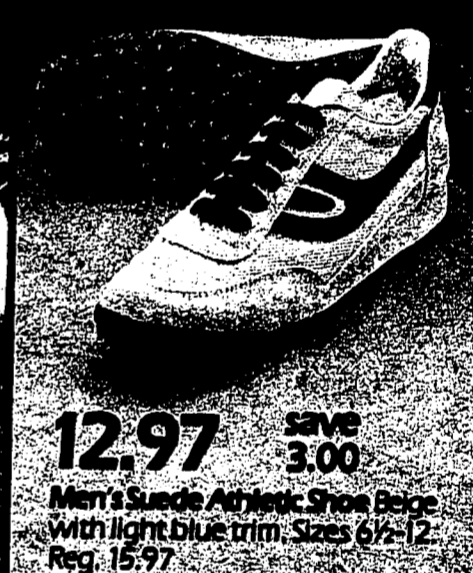

12.97 save **3.00**

Men's Suede Athletic Shoe Beige
with light blue trim. Sizes 6 1/2-12.
Reg. 15.97

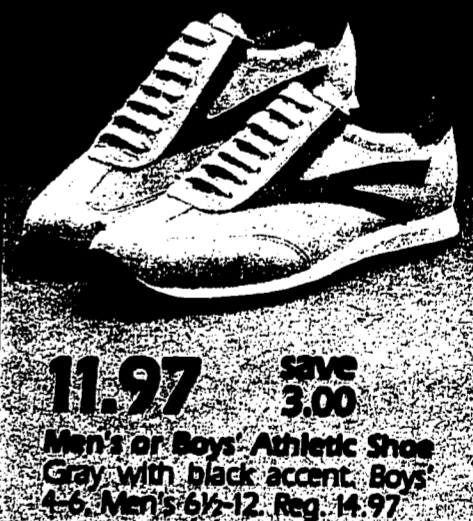

11.97 save **3.00**

Men's or Boys' Athletic Shoe
Gray with black accent. Boys
4-6; Men's 6 1/2-12. Reg. 14.97



12.97 save **2.00**

Men's Casual Shoe Sand color.
Split leather, assorted sizes
7-12. Reg. 14.97



11.97 save **3.00**

Leather Athletic Shoe Two-tone
wedge, imitation suede. Sizes 5-
10. Reg. 14.97

TG&Y® family centers

Items Available In TG&Y Family Centers Only

SALE IN EFFECT SUN., AUG. 8 THRU SAT., AUG. 14
At Those Locations Where TG&Y Is Closed On Sundays, Sale In Effect Mon., Aug. 9-Sat., Aug. 14

Most items at reduced prices.

Items Available in TG&Y Family Centers Only

20% off exclusive Jr. or Girls' Walk-On tops!

Jr. or Girls' Walk-On Knit Top Campus casuals for less! Placket collar, interlock knit. In a vast array of fall colors. Sizes S-M-L. Reg. 14.00



Wrangler

14.97

Jr. Wrangler® Boy-O-Boy™ Jeans It's the style and fit you want from denim at the price you can afford! Waist size 25-32. A value advantage... TG&Y!

9.97 save 2.00

Girls' 7-14 Wrangler® Jeans They're No-Fault® 100% cotton denim with Sanforset finish. Wrangler® offers a comfortable price on a trusted brand name.

25% off Veronica Lee Coordinates!

Girls' Veronica Lee Coordinates A back-to-school special! Denim jeans with Bear or Unicorn pocket emblem, or pleated pants. Sizes slim or regular 4-6X, reg. 12.47. In 7-14 sizes, reg. or slim, choose from designer or pleated pants of rust, blue or berry, reg. 14.47. They'll all coordinate well with stripe, plaid or print interlock knit tops with Bear or Unicorn emblem and puff sleeve, or tops with ruffle, patchwork or lace trim. Sizes 4-6X, reg. 7.47 to 8.47. Sizes 7-14, reg. 8.47 to 9.47.

TG&Y family centers

Items Available in TG&Y Family Centers Only



4-6X Top
save 20%
7-14 Top

5.97
6.97

4-6X Jeans
save 36%
7-14 Jeans
save 36%

6.97
7.97

Fall traditions at their very best. The classic woven plaid top is never at a loss for style. Wear it here, there, anywhere you go. 50% polyester/50% cotton. For little girls 4-6X, reg. 7.47 and girls 7-14, reg 11.00.

Easy-going wearability. That's what they have that makes them so great. Jeans. Terrific and sensible. 65% polyester/35% cotton blue denim with back pocket stitching. For little girls 4-6X, reg. 8.97; girls 7-14, reg. 9.97.

6.97 save 22%

Jr. Knit Top Boldly stated colors in three's. Royal/black/red, berry/black/beige or beige/black/purple. 50% polyester/50% cotton. Sizes S-M-L. Reg. 8.97

9.97 save 4.00

Ladies' Blouse Autumn stripes fit your life style to a T. Especially when they're done so nicely in 65% polyester/35% cotton. Sizes 8-18. Reg. 13.97

13.97 save 3.00

Jr. Jeans Give her the confidence a great fitting pair of stretch jeans offers. A variety of back pocket designs. Sizes 3-15. Reg. 16.97

14.97 save 3.00

Ladies' Jeans Try a trouser style jean for a fall change of pace. You'll love the refined shape. The good, clean lines. Sizes 8-18. Reg. 17.97

TG&Y family centers

Most items at reduced prices.

Items Available In TG&Y Family Centers Only

**Take 20% off the top ...
and run with it!**



| | | | |
|----------------------------------|--------------|---------------------------------|--------------|
| Solid Top save 2.00 | 7.97 | Striped Top save 2.00 | 8.97 |
| Jacket save 3.00 | 10.97 | Pant save 3.00 | 12.97 |
| Fanny Warmer save 3.00 | | 12.97 | |

Ladies' Active Wear These wear-anywhere active separates are for those who live life in leaps and bounds and for those who demand comfort in their quiet leisure! Team up matching or contrasting colors of red and plum. Pants of 100% Creslan acrylic, reg. 15.97. 30" long Fanny Warmer T-Shirt Skimp is 100% Creslan acrylic, reg. 14.97. Missy solid color top of 50% polyester/50% cotton, reg. 9.97. Missy striped top of 50% polyester/50% cotton, reg. 10.97. Sleeveless Jacket is 100% Creslan acrylic, reg. 13.97. All separates come in S-M-L sizes.

TG&Y family centers

Items Available In TG&Y Family Centers Only



Your choice

.88 save **26%**

Misses' Screen Print Bikini 100% stretch nylon with novelty sayings. One size fits 5-7. Reg. 1.19

Misses' Hiphugger The soft sparkle of Enkalure nylon with cotton crotch. Fashion colors, pretty lace trim. Sizes 5-7. Reg. 1.19

Knickers for the night

6.99

Ladies' Knicker Sleep Set Night and lace... an incomparable combination. Fresh as ever on a kicky little knicker set. Destined for sweet dreams. 2 pieces, each 100% nylon. Lovely pastels in pink, lilac or blue. Sizes S-M-L. Reg. 7.97

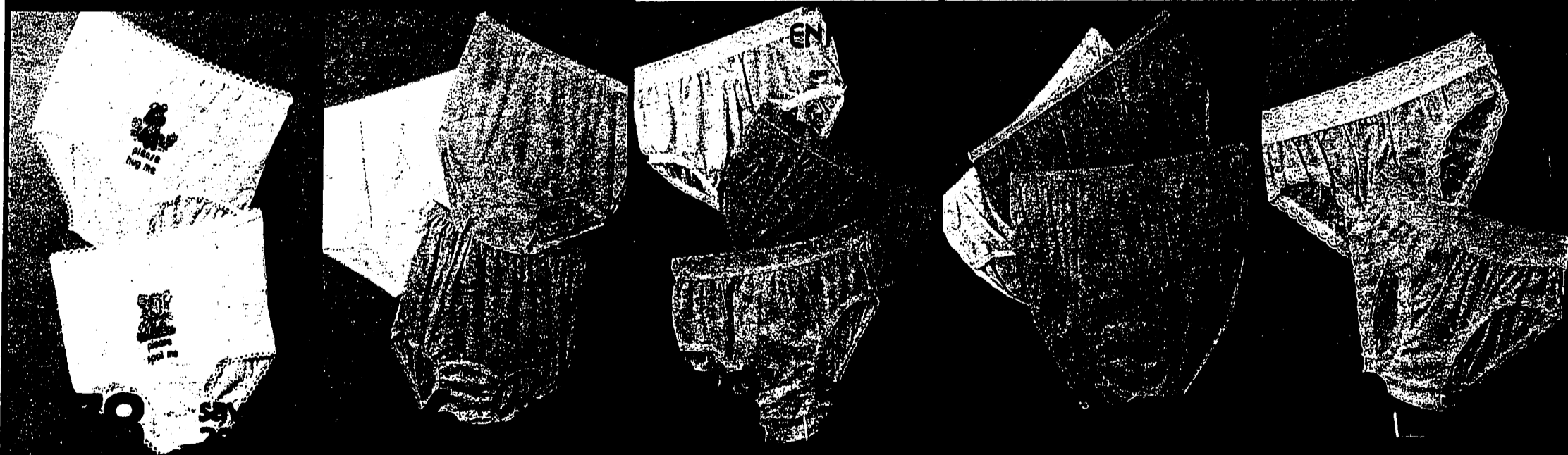

TG&Y family centers

Items Available In TG&Y Family Centers Only

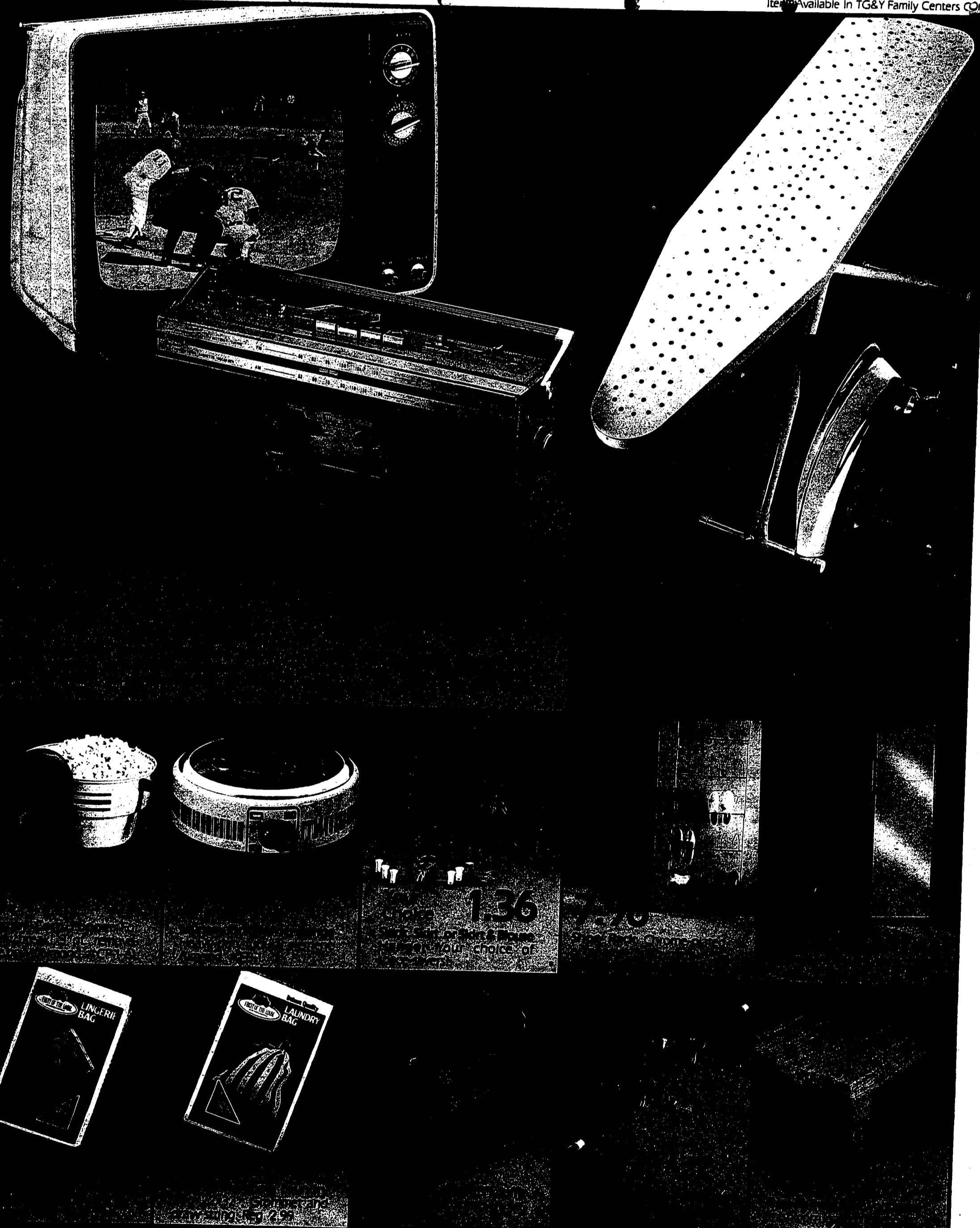

TG&Y family centers

Items Available In TG&Y Family Centers Only



Pack up all your school needs and save money!

Tote Bag **2.57**
 School Bag **2.96**

Tote Bag/School Bag These bags are as useful as they are fashionable! Selection includes Candy, Crayola, Cookie, Annie, and M*A*S*H designs.

TG&Y family centers

Its Available In TG&Y Family Centers Only

Your Value Advantage is... name brand savings!

fiddle faddle
Clusters of popcorn with peanuts in a delightful glaze.
NET WT. 7 OZ.
WITH PEANUTS

2 BXS 1.00
Fiddle Faddle Caramel popcorn clusters with peanuts, 7 oz. Limit 2

ADVANCED FORMULA
crest
TOOTH PASTE
NET WT. 6.4 OZ.

1.06
Crest Toothpaste Buy 2, get 2 FREE! Regular, Mint or Gel. 6.4 oz. Limit 2

Bruiser 2 Ply
Leaf & Lawn Bags
12

1.99 FESCO
Fesco Bruiser Leaf Bags Heavy duty, 6 bushel capacity, 12 ct.

OIL OF OLAY

2.99
Oil of Olay Discove Moisturizing lotion, Limit 2

15¢ OFF
Tide
EXTRA ACTION
AMERICA'S FAVORITE

1.87
Tide Laundry Detergent Price reflects 15¢ off label, 49 oz. Limit 2

Gatorade
THIRST QUENCHER
Lemon-Lime
NET WT. 32 OZ.

.67
Gatorade Thirst Quencher Lemon-Lime, 32 oz. Limit 3 ea.

VIDAL SASSOON

1.99 ea.
Vidal Sassoon Shampoo or Rinse, 12 oz. Limit 3 ea.

VIDAL SASSOON
Re-Moisturizing Creme

1.99
Vidal Sassoon Re-Moisturizing Creme, 4 oz. Limit 3

ONE DAY
Plus Iron

2.37
One Day Plus Iron, Price reflects 2¢ off label, 2.20 ea. Limit 2

FREE 15¢
FLINTSTONES
FREE U-Point

2.37 2.68
Flintstones Toothpaste Buy 2, get 2 FREE! Regular, Extra C, or With Extra Whitening. 4.2 oz. Limit 2 ea.

CLAIROL
final net
30% OFF
regula unsc invisible

1.78
Clairol Final Net Hair Spray Price reflects 30% off label, 8 oz. Limit 2

QUAKER STATE
DeLuxe
MOTOR OIL

.84 qt.
Quaker State Motor Oil 5 qt. Limit 6 qts.

TG&Y family centers

TG&Y's policy is to always have advertised merchandise in adequate supply in our stores. In the event the advertised merchandise is not available due to unforeseen reasons, TG&Y will provide a Rain Check, upon request, in order that the merchandise may be purchased at the sale price when it becomes available, or you may purchase similar quality merchandise at a similar price reduction. It is the policy of TG&Y to see that you are happy with your purchases. It is TG&Y's policy to be priced competitively in the market. Regular Sale Prices may vary market by market, but the sale price will always be as advertised. We will be happy to refund your money if you are not satisfied with your purchase. VISA® and MasterCard® accepted.