

Bob Evans again seeks hearing before planners

By KATHY JENNINGS

Plans for a Bob Evans Restaurant that were killed by the Novi City Council earlier this year will be resurrected at a hearing before the planning board October 27.

Rejection of the site plans prompted the restaurant corporation to file a law suit asking that the ordinance used as grounds for rejecting the plans be struck down.

Since then it has been determined the city council had no power to approve or reject the preliminary site plan.

In proceedings before Oakland County Circuit Court Judge Fred Mester, the city argued the lawsuit is unfounded because the plans that were dismissed were preliminary site plans. Final site plans had not been submitted to the city and the lawsuit would not be valid until final plans were submitted for council consideration.

Bob Evans has now submitted a final site plan which must be reviewed by the planning board, which will make a recommendation to the city council.

However, the submitted plans are "essentially the same" as those already rejected by the city, according to Bob Evans' attorney Norman Hyman.

"I haven't gone over the plans that closely, so I wouldn't want to say they are exactly the same as those already submitted, but I believe they are close to being the same," Hyman said.

Hyman noted the final site plans had been submitted "in hopes they will be approved and in the hope it may clarify the issues now pending. We thought this would clear things up and make for a more orderly presentation of the lawsuit."

Another twist to the case is that the city has revised the ordinance used to keep Bob Evans from locating near the front of West Oaks Shopping Center since the time the restaurant corporation submitted the original site plans.

Whether the original ordinance or the amended ordinance will be used to judge the final site plan has not been determined. City Attorney David Fried contends the site plan submitted

for final approval must comply with the newly-enacted amendment to the restrictions regulating development under the planned development option — an option available to developers in the regional center area around Twelve Oaks Mall.

When asked which set of standards he expects to be applied to the final site plan review, Hyman said: "I expect we'll be given a hearing on our site plan application, other than that I don't want to speculate."

The court has made no determination whether the amended ordinance will become a part of the lawsuit.

"Until the court decides that question we're taking no position on whether the (amended) ordinance applies to our plan or is valid," Hyman said. "That is the next step."

But Hyman already has asked the court to reject the city's attempts to introduce the amended ordinance into the suit, because the amendment was enacted after Bob Evans filed its suit.

Continued on 7-A

Red Lobster restaurant welcomed to mall area

By KATHY JENNINGS

For the sea food lover in you, Novi City Council members have welcomed a Red Lobster restaurant to the community, but not without a minor struggle.

Red Lobster representatives received half of what they asked for when they appeared before the city council Monday to seek a liquor license and site plan approval for the restaurant to be located near the entrance of Twelve Oaks Mall.

Council members rejected the liquor license request, saying the city would hold its one remaining license for a "more intense use," such as a convention center.

But after much debate the council approved the site plans for the sea food restaurant.

Council members struggled over the decision due to a city requirement that restaurants developed under a planned development option be located at least 1,000 feet apart, a stipulation designed

to prevent the proliferation of fast food restaurants. They also indicated they would not be receptive to requests from the Taubman Company for a third restaurant along Novi Road in the future.

Concerns with traffic generated by the restaurant at the already-congested mall entrance also caused council members to hesitate over their decision to approve Red Lobster's plans.

Dan Crowin, a Taubman Company representative speaking on behalf of Red Lobster, asked the council to waive the 1,000 foot requirement because other pieces of property around the mall were unsuitable due to topographical considerations. Problems in finding a suitably sized location for the restaurant also have been created by the city's lot split ordinance.

In order to conform to city requirements two lots were joined, putting the Red Lobster on a piece of property which is substantially larger than required by the zoning ordinance, Crowin said.

He also asked the council to consider the restaurant company's "display of cooperation." He noted the size of the lot, quality of architecture which includes brick and deviates from other Red Lobster restaurants, and landscaping which exceeds city requirements.

"This is one of Red Lobster's most unique buildings," Crowin said.

City Planner Charles Cairns recommended approval of the site plans, say-

Continued on 13-A

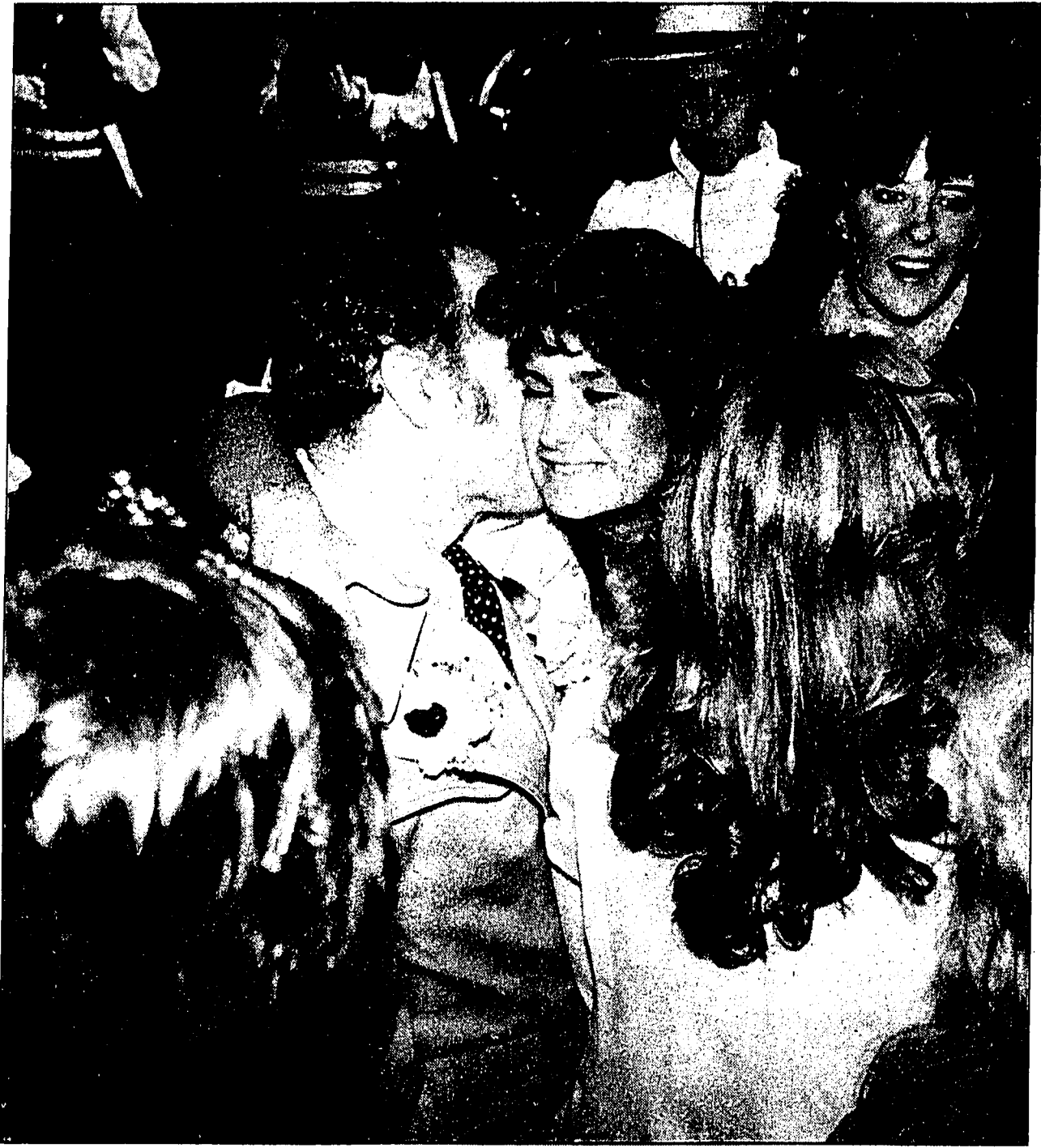

Fatherly congratulations

There was a rush of those who wanted to congratulate Novi homecoming queen Debi Seaman when she was recognized at Friday's

football game, but Dad got their first with a warm hug and kiss for his daughter. (News photo by Steve Fecht)

Enrollment down by 70 students

By KAREN RICE

Enrollment in Novi schools dipped slightly for the second year, with 70 fewer students attending classes this year than last.

A count of students released at the October 7 meeting of the Novi Board of Education showed 3,094 students enrolled in Novi's six schools, a decrease of about two percent from the 1981 Fourth Friday count of 3,164 students.

Last year's decline was the first time since 1970 the school district lost students. Enrollment dropped by 22 students from 1980 to 1981.

However, Superintendent Dr. Robert Piwko said the decrease fell within the district's enrollment projections for this year. He said school officials had expected enrollment to remain close to last year's level or show a slight decline. No increase was expected, he said.

Novi Middle School North recorded the largest drop in student population, with 83 fewer students enrolled this year. The population fell from 565 fifth and sixth grade students in 1981 to 482 this year.

The student population at Village Oaks Elementary also showed a drop. Only 296 students are enrolled at the school this year, in contrast to last year's 338 students — a decrease of 42 children.

However, both Novi Middle School South and Novi High School showed increases this year. There are 578 seventh

"In the future, we may want to make some reductions (in teaching staff). We'll want to look at (declining enrollment) and continue to look at it."

— Dr. Robert Piwko, Novi superintendent

port staff will remain the same.

Trustee Robert Schram expressed concern that the district was hiring replacements for five teachers for the coming school year in light of declining enrollment.

But Piwko responded that although a reduction in the teaching staff had been considered, "the way the numbers fall, it just doesn't work."

Piwko said if the district had decided to reduce its teaching staff, "what we would have ended up creating at the elementary level would be a lot of turmoil and turnover and the same with the other schools."

Continued on 7-A

Spirits distributor to operate in Novi

A major importer and distributor of liquor and spirits is moving its world headquarters to Novi.

The Mohawk Liquor Company, a division of Foremost-McKesson, Inc., has already started to move into the former Adell Industries building at I-96 and Novi Road.

Ray Hyde, a Foremost-McKesson official based in the New York office, confirmed last week that Mohawk Liquors already has started moving from its existing facility in Detroit to the new headquarters in Novi.

"We simply outgrew our existing facilities," said Hyde. "We started searching for an outside warehouse facility about a year ago, but it quickly became apparent that more storage capacity was not going to be the answer.

"Due to the present size of Mohawk

and our projected growth, we decided we needed a larger facility for increased production as well as warehousing."

Hyde said Mohawk was "very excited" about moving to Novi and said the Adell Industries building was ideal for its operations.

"We need very high fire standards because we're dealing with high levels of alcoholic content," he explained. "When spirits are imported from abroad, they're often shipped over at 180 proof and then refined down to appropriate levels.

"This building answers all our needs," he added. "It's the safest building I've ever seen in terms of fire protection. Adell used to manufacture windshield solvent here so the fire standards are extremely high. It has an

Continued on 7-A

Former mayor to get involved ... in Washington

By KATHY LAVEY

What do the City of Novi, Washington D.C., and a tiny school for the handicapped in the African state of Namibia have in common?

Romaine Roethel, Novi's first woman mayor and her husband, John, both active in local politics since they moved to Novi from Detroit in 1971, will soon make another move.

This time it will be to Washington D.C. where John, retired from Ford Motor Company, will work as a patent attorney and Romaine, mother of four grown children, will do what she does best — get involved, probably in politics.

Politics are nothing new to the Roethels.

Monday, October 25 has been named Roethel Day. John and Romaine Roethel will be honored for their past service to the community at a gathering at 7 p.m.

She and her husband entered Novi politics shortly after their arrival in the city, when he received an appointment to the planning board. She began attending city council meetings to "express some opinions" about development in

her subdivision, and soon found herself hooked.

"I discovered there was going to be a vacancy on the council and I really lobbied for the appointment," said Roethel. She got it in April 1973. The following November she ran for a four-year term — and got the highest number of votes in the race.

"Campaigns have never been the same in this city since," she says, laughing. "I put up posters, passed out literature, rang a lot of doorbells and nobody had done that before ... they called my campaign workers 'Roethel's Raiders'."

In 1977, Roethel quit the council, not to get out of politics but to get in even deeper. She ran for mayor and won.

Continued on 13-A



SECOND FRONT PAGE

WALLED LAKE

Page 4-A THE NOVI NEWS—THE WALLED LAKE NEWS Wednesday, October 20, 1982

in the NEWS

Walled Lake abandons super sewer

By KAREN RICE Road and to begin expansion of the through Wayne County to its southern... The council's decision followed release of the Huron Valley North Service Area Amended Facilities Plan that recommended the Walled Lake plant be abandoned and Walled Lake tie into super sewer, proposed to run from White Lake Township through Commerce Township, Wolverine Lake, Wixom, Walled Lake, part of Novi and treatment plant.



FLASH FINISH: When Phil Jerome does something, he doesn't mess around. And the recent Run for Reyes celebrity fun run in which he participated last weekend was no exception. Jerome had the odds stacked heavily against him — as he battled everything from a starting spot in the parking lot to jostling and shoving of ambitious runners. And let's not forget all the women running after him as he bared his legs in true sprinting style. Well, it wasn't really all that tough, was it? See his column, "After the fact," on Page 14-A.

WEDDING BELLS were pealing for several local personalities Saturday. Wixom Police Officer Alan Blashfield tied the knot with Debbie Dinsler, a clerk in the Novi Police Department, at Church of the Holy Cross in Novi. (Special note: The couple did not exchange vows in uniform.) And Novi Consulting Engineer Ray Cousineau married Maria Kearns the same day. That was a painful experience for Cousineau's partner, Joe Kapelczak, whose recent dental work caused him to suffer through the reception. Best wishes to both sets of newlyweds.

DON'T FORGET to support your community! There's all kinds of good stuff going on this week — from the opening of Jaycee haunted houses in Walled Lake and Novi, to an opera at Walled Lake Central, to homecoming at Walled Lake Western, to benefits for Dick Edgington to... well, you get the picture. Now get the details. They're all inside today's issue.



Fireman for a day

If Walled Lake's newest firefighter looks a bit young to you, you're not alone. Chris Foley, 2, isn't quite ready to battle blazes yet but he was old enough to enjoy Walled Lake Fireman Glen Bromm's tour of the city's fire equipment at the recent fire department open house. Bromm let

whether the city joins super sewer or stays on its own, but treatment costs would raise substantially, possibly as cited cost as the prime factor in their decision. Joining with super sewer would cost Walled Lake \$1,744,000, the most recent estimate given to the city. If both Novi and Walled Lake continue to use the treatment plant, it must be expanded and those improvements interceptors and plant would remain

Police dispatching may be combined

By KAREN RICE Police dispatching services for Walled Lake and Wolverine Lake may be consolidated within the next few months. The Wolverine Lake Village Council authorized Administrator Bill O'Brien to investigate that possibility October 13 after O'Brien revealed the City of Walled Lake had suggested the two share dispatching services. O'Brien said he had few details because the proposal "just came up," only a few hours before the council meeting at which members accepted a request for retirement from Betty Bruder, one of Wolverine Lake's two full-time dispatchers.

Walled Lake City Manager J. Michael Dornan confirmed the city had suggested Wolverine Lake consider sharing dispatching with them and said it was something Walled Lake has been considering for some time. He said the city "could accommodate" a pair of trained dispatchers from Wolverine Lake. Dornan said the city also has long supported the concept of shared services between municipalities and suggested this might be the most

Search underway for village manager

By KAREN RICE The Wolverine Lake Village Council has begun its search for a new administrator after accepting the request for retirement from Bill O'Brien at the October 13 meeting. O'Brien, the village's top appointed official for the past 10 years, will retire February 28, 1983. He has also asked to

take about six weeks of vacation prior to that date and is planning to leave in mid-January. The council authorized O'Brien and clerk Donna Thorsberg to begin advertising in local newspapers and trade journals for a new administrator. After discussing whether to set up a committee to screen applicants for the administrator's job, the village council decided that all members should be in on the selection process. All will receive copies of resumes and letters of inquiry, individually narrowing the field down to their top choices. The full council will then convene to determine finalists and will interview those candidates in public meetings. However, several council members expressed concern at the prospect of operating the village without an administrator for several weeks or months. Council Member Tom Gerhard said he was not happy with being left "a little high and dry" between administrators and questioned whether O'Brien could alter his vacation plans, dividing his time off into two blocks. He also suggested it might be wise to hire an administrator before O'Brien leaves and name him acting administrator.

Trustees will study finances

Walled Lake's Board of Education will hold a special meeting next Monday to examine the official audit from the 1981-82 school year. The meeting will be held in the Administration Building in Walled Lake at 7:30 p.m. The board set the special meeting to discuss the district's financial condition in greater detail after receiving the official audit at its October 4 meeting. Lyle Algate of the accounting firm of Plante & Moran reported that the Walled Lake Consolidated Schools finished the 1981-82 school year with a Fund Equity (savings account) of \$790,400. Algate reported that the district spent approximately \$379,000 more than it took in last year. Total revenues for 1981-82 year were roughly \$23.8 million, while expenditures totaled \$24.26 million.

Dick's fund gets assist from events

There will be lots of activity for the next two weeks among businesses and service groups who are backing the drive to buy a van for Dick Edgington, 16, of Wolverine Lake. Dick is a victim of cerebral palsy who lives with his foster mother, Carol Pitcher, a special education teacher in Waterford. Thanks to community fund-raisers organized by family friend Jackie Somerville and sponsored by the Walled Lake Jaycees, Dick is moving ever closer to what seemed like a dream for him just weeks ago. More than \$2,500 has been raised to purchase a van for Dick and a wheelchair lift has been contributed to the effort. During the next two weeks, that sum is expected to grow considerably — with four special fund-raisers slated. Beginning tomorrow (Thursday), the Walled Lake Jaycees will begin operating their haunted house at 421 Pontiac Trail. A portion of the proceeds will go to help Dick. In addition, friends will sell pumpkins at the haunted house. Thanks to Jaycee Dave Roddy, the pumpkins were donated to the cause and all funds from their sale will be added. On Saturday (October 23), the Walled Lake Big Boy Restaurant will give half the money raised during breakfast, from 6-11 a.m., according to owner Georgine Hayes. And on Sunday (October 24) from 8-11 a.m., the Walled Lake Big Boy will do the same thing, owner Tom Borin says. Workers at both restaurants have agreed to volunteer their time to assist in the fund-raisers. And Now Printing on Pontiac Trail has printed up 1,500 flyers to advertise the fund-raisers, at no cost to the project. They will be distributed at both restaurants, the haunted house and churches this weekend. Topping off the trio of events, the Walled Lake United Methodist Church's teen club is completing plans for a rock-athon October 30 at the church. Teens are seeking sponsors for hours they have pledged to rock in rocking chairs, with proceeds going to Dick's fund. The youngsters are especially excited, Somerville says, because Dick is expected to join them for part of the event. Somerville points out that businesses, groups and individuals have been very supportive of the project and is encouraging other area residents to get behind the effort. For more information, call her at 624-4137.

RYMAL SYMES - REALTORS Since 1923 - 2182 Heatherbrae-Novi BEAUTIFUL GARDEN ROOM - Relax and have your morning coffee in this large garden room just off the huge country kitchen in this custom built 2 story in lovely Turtle Creek. Great terms for assuming the existing mortgage or super new mortgage terms. Call 478-9130 RYMAL SYMES 3415 Burno Road-Milford lovely place to spend the rest of your life. This extraordinary three story cedar home is hiding in the middle of its own two wooded acres. Horse barn and corral complete this executive home located in Milford. Call 478-9130 RYMAL SYMES 11003 Silver Lake Rd.-Green Oak Country squire English Tudor estate on 11 wooded acres. Over 4000 sq. ft. plus of luxury personified. Walk-out lower level completely finished with full kitchen and bath. This home was built with all the custom features you would expect. This corporate owned estate is priced at \$155,800 for immediate sale. You really must call for details. Call 478-9130 RYMAL SYMES

ABSENTEE BALLOTS CITY OF WIXOM To the Qualified Electors of the City of Wixom: Absentee Ballots for the Tuesday, November 2, 1982 General Election may be obtained from the City Clerk's Office at the Wixom City Hall, 49045 Pontiac Trail, Wixom, Michigan 48096, from 8:30 a.m. to 5:00 p.m., Monday thru Friday, and on the last day, being Saturday, October 30, 1982 from 8:30 a.m. to 2:00 p.m. Publish: Oct. 13, 1982 June Buck, City Clerk Oct. 20, 1982 City of Wixom Oct. 27, 1982

Sylvia Whitmer concentrates on learning

EDITOR'S NOTE: There are five new elementary school principals in the Walled Lake School District this year. This is the last in a series of articles introducing them. By PHILIP JEROME

What elementary school principal in the Walled Lake School District is also a school board member? The answer is Sylvia Whitmer, the new principal at Oakley Park Elementary School. She's not a member of the Walled Lake school board, of course, but she is a member of the school board in Birmingham. And, she says, her dual roles as principal and board member are totally consistent with her personality and interests.

"I've been fascinated all my life with how people learn," she said. "Learning theory and the psychology of learning have always been special interests, and I've explored them from every angle from classroom teacher to principal and school board member." Born in Winnipeg, she moved with her family to Michigan and attended elementary school in Richmond until seventh grade when the family moved again to Detroit. "Richmond was a small town and I attended a small-town country school," she said. "It's somewhat ironic to be a principal now in Walled Lake because the big field trip of the year back in Richmond was to travel by bus out to the Walled Lake Amusement Park."

University's Institute for Research on Teaching from 1976-81. She earned her Ph.D. from Michigan State in 1981. Although it's been 18 years since she's worked as a classroom teacher, Whitmer says her experience as an educational researcher has prepared her well for her new job. Continued on 15-A

meet your principal



Sylvia Whitmer, principal of Oakley Park Elementary, says she fell in love with the students and staff of her new school

returned to South Redford where she remained as a high school teacher until 1964. "I took time off to raise my family of three children," she explained. "But I never lost my interest in learning and education. While my children were growing up, I volunteered a lot of time in the schools they attended. I worked as a math aid, a media aid and she just about any other type of aid that was needed," she recalled. After all her children were in school, Whitmer continued her study of education on a part-time basis, earning her education specialist's degree from Wayne State in 1973 and then working as a researcher at Michigan State

TG&Y OPEN DAILY 9 to 9 SUNDAY 11 to 5 Sale thru Oct. 24, 1982 Rubbing Alcohol 16 oz. bottle 70% Isopropyl Alcohol 3/\$1 Limit 3 Game of Monopoly \$5.77 Dawn Sayelle Yarn Choose from rainbow of colors 4 oz. skein. 86¢ Skein Shower Curtain and Ring Coordinated Set \$3.97 Blue Jogger Tennis Shoes Men's and boys' popular sizes \$4.00 Pair 110 lb. Weight Set Complete with sleeved barbells, dumbbell bars and collars. \$19.97 Star War Figures \$2.47 Hot Wheel Cars Die Cast \$99¢ Tide America's favorite laundry detergent. 49 oz. box. \$1.84 Limit 2 Crest Toothpaste 6.4 oz. Regular or Mint 99¢ Limit 1 Kitty Litter 25 lb. \$1.97 Limit 2 Leaf Rake Green Metal \$1.00 Shredded Foam Ideal for craft projects. While quantities last! 1 lb. bag 2/\$1 Limit 2 Timex Watches Discounted 20% OFF Mfr. Prices Car Ramps One piece steel construction. One pair supports 6500 lbs. \$13.88

Wixom considers noise regulations

Wixom officials are considering an amendment to the city's go-cart ordinance as a means of dealing with noise created by ultralight aircraft stationed at Spencer Memorial Airport.

The problem was brought to light when Larry Rourke, records clerk for the Wixom Police Department, complained about the "noise pollution" created by the aircraft at the September 28 council meeting.

Describing them as "hang-gliders with motors," Rourke said the noise is a problem because the one-man aircraft, which are not regulated by the Federal Aviation Administration, fly low to the ground at a very low rate of speed.

Additional complaints about the ultralight aircraft were expressed last week by Council Members William Wylie and Wayne Glessner.

Wylie said the ultralights are "noisy and take a long time to fly overhead" and Glessner expressed concerns about the height at which the aircraft are flown.

"They fly those things within 50-75 feet of high tension wires and they're very low over the lake," said Glessner.

City Attorney Thomas Connelly, who was directed by the council September 28 to investigate solutions, said last week that the city's existing go-cart ordinance would seem to answer all concerns.

"The go-cart ordinance requires local licensing and restricts decibel levels," said the city attorney. "The wording is perfect except that it applies only to go-carts."

It would be a very simple matter to amend the ordinance so that it applies to these ultralight aircraft as well.

The council subsequently directed Connelly to pursue an amendment to the go-cart ordinance, but no date was established for the proposed amendment to be presented for council approval.

Providence offers medical speakers

Providence Hospital's speakers bureau offers a wide variety of health and wellness topics to community groups and organizations.

The program, coordinated by the community health education department, will provide a program speaker free of charge upon request.

"People today are more interested than ever before in adopting lifestyles which enhance their health and well-being," observed Pam Ashworth, coordinator of community health education. Available topics include weight control, nutrition, parenting, child and adolescent development, aging and the proper use of medications.

Ashworth said she also will be happy to locate speakers for topics by special request.

"Providence always has responded to requests from the community for speakers," said Judy Mecum, assistant director of community relations who is helping coordinate the program.

"Health care professionals have valuable information to share with individuals concerned about their health and well-being.

Persons interested in getting a speaker for their group or organization should call the community health education office at 552-9041 for details. There is no charge for the service.

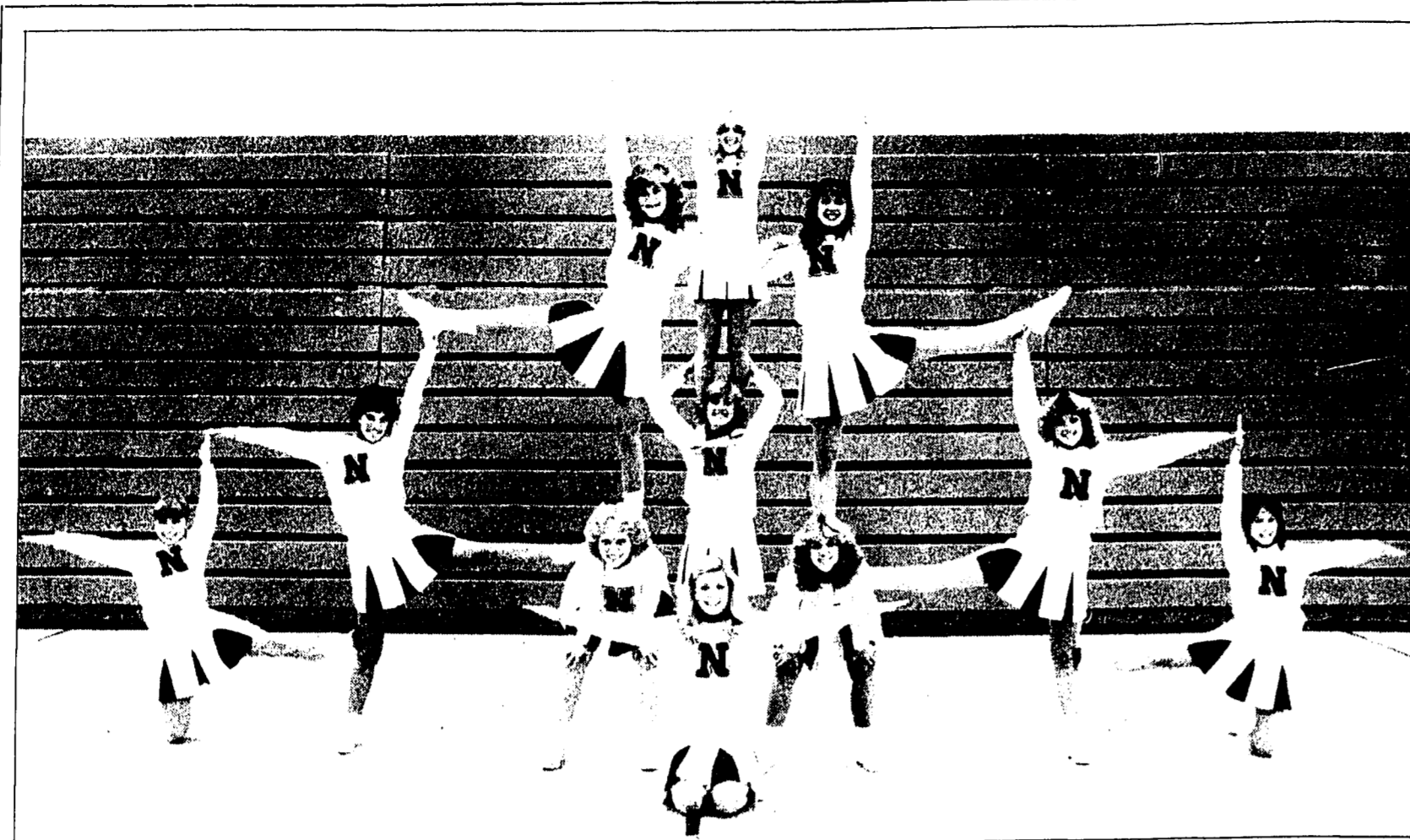

Hmmm, how do we identify the award-winning members of the Novi varsity cheerleading squad for you? Well, that's Leslie Crowell kneeling in front. And the only three girls with both feet on the ground are (left to right) Kellie Abbott, Jill Shankel and Wendy Sayre. That leaves the back row of (left to right) Carolin Drew, Tina Thomas, Carolyn Pilch, Sally Szuma, Terri Lewis, Jill Brayton and Karen Hsu. (News photo by Steve Fecht)

Camp honors cheerleaders

Anyone who's seen the Novi cheerleaders at football games this year will understand why the squads earned numerous awards at cheerleading camp this summer.

After practicing three hours per day and five days per week during the month of June, Novi's varsity and junior varsity cheerleaders participated in the Dynamic Cheerleaders Association camp at Adrian College during the week of June 28-July 1.

The 11 varsity cheerleaders and nine junior varsity cheerleaders were noted for their enthusiasm and spirit while at cheerleading camp. Both squads took awards for outstanding jumps, stunts and group mounts.

They also won outstanding spirit and outstanding cheerleading skill awards.

The junior varsity squad took first place overall in its division, while the Wildcat varsity finished fourth overall. The group also took the most spirited of the camp award.

Senior Jill Shankel led the varsity squad as captain at camp, while junior Marie Nameth was camp captain for the junior varsity.

The cheerleaders were coached by Valerie Krueger during the summer. She continues to lead the varsity cheerleaders. Chris Hamilton now coaches the junior varsity.

Walled Lake offers to dispatch police

Continued from Walled Lake, 1

economical and efficient solution for both communities.

Walled Lake dispatchers already handle all calls between midnight and 4 a.m., a service for which Wolverine Lake pays \$1,200 annually.

The Wolverine Lake switchboard operates on two eight-hour shifts, from 8 a.m. to 4 p.m. and 4 p.m. to midnight, seven days weekly.

O'Brien told council members he had no details of Walled Lake's plan to consolidate dispatching, but said he thought the city was interested in adding two dispatchers to its staff and having Wolverine Lake continue to pay their salaries. The consolidation would eliminate part-time help, O'Brien said.

O'Neill opposed the concept, saying he thought Wolverine Lake should retain its autonomy and keep its dispatchers. He said village residents would be back him in attempting to keep dispatching services within their local police department and suggested the council

'It's just getting to a point of dollars. Somewhere along the line we have to do something to consider the future and what's going to happen.'

— Geri Matkowski, Wolverine Lake

"I think about it" before consolidating services.

But Council Member Geri Matkowski said the option was one that must be considered. She pointed out state and federal funds are being slashed frequently and that if the village council does not make some painful cuts in its budget, the only alternative could be raising millage—which she said would cost more people than seeing dispatching go to Walled Lake.

"It's just getting to a point of dollars," she said. "Somewhere along the line we have to do something to consider the future and what's going to happen."

Before Walled Lake's proposal was considered, however, council members discussed whether to replace Bruder with a full-time or part-time help.

Council Member Tom Gerhard questioned why the village couldn't get by with one full-time and four or five part-time dispatchers. He said that would save money, both in benefits and

When Gerhard asked O'Neill to explain the difference between a full-time dispatcher and a chief dispatcher, O'Neill said "they're the same thing really, but Betty's in charge of the other dispatchers." He said as chief dispatcher, Bruder helps with scheduling the part-time workers, makes recommendations to him and works the day shift.

"Why doesn't this all come under your jurisdiction?" Matkowski asked.

"It does," O'Neill said, "and I would recommend the same thing as Betty: that Bobbi Martin become chief dispatcher."

Matkowski suggested it would be more economical for O'Neill to take back the responsibilities delegated to chief dispatcher following Bruder's retirement. Matkowski, a former dispatcher for the Novi Police Department, said the village needed to look hard at where it can make cuts in operating costs, proposing dispatching as a good place to start its considerations.

Operetta scheduled at Central

It's not exactly a French soap opera, but "The Chimes of Normandy" has all the intrigue, romance and drama of one.

Not to mention an extensive musical score.

Walled Lake Central students will present "The Chimes of Normandy" this weekend at the high school, showcasing the musical talents of the cast in a translation of a French operetta.

Jody Darling, a member of the cast, says the show will be entertaining for all age groups and has an involved plot with frequent twists of fate.

Performances will be given Thursday and Saturday nights at 7:30 p.m. in Central's auditorium. Tickets are \$2.50 per person.

"The Chimes of Normandy" chronicles the romantic problems of Germaine, played by Shelly Spicer, whose guardian has arranged her engagement to the Baill, an old unattractive mayor played by John Stoddard. Germaine's guardian Gaspard is a miser portrayed by Kevin Herrara.

To complicate the situation, Germaine is also semi-engaged to Grencheux, a cowardly sailor played by Bob Lewis. Grencheux, supposedly saved Germaine's life by pulling her out of the ocean, when she was younger, and the proposed marriage is his reward.

Add to the plot the legend of a haunted castle, the son of a the Count of Corneville (played by Jeff Garland) and the mystery of stolen family jewels—and "The Chimes of Normandy" starts to get quite intriguing, Darling says.

O'Brien retires, search begins for chief

Continued from Walled Lake, 1

allowing for more transition between O'Brien and his replacement.

"We're looking at at least six weeks without an administrator," Gerhard said. "I just wonder if that's prudent for the administration of the village."

O'Brien was reluctant to change his vacation, contending it would not affect the operation of the village.

"If I take it now—which I'll do—we still won't have anybody while I'm gone," he said.

"We were without an administrator for a year before they hired me," he added.

Council President Tim Kozub said O'Brien's request for six weeks of this winter was not out of line with his previous vacations.

"Generally there's been a three-to-four-week period he's taken off in the past," Kozub said.

Last winter O'Brien took five weeks of in January and February with council approval. He also was off for two weeks in June.

But Kozub agreed with Gerhard that it might be a good idea to hire an administrator before O'Brien leaves.

Village Attorney Thomas Connelly, who recently helped select a new administrator for the Village of Milford, said that could be difficult. He said Milford's selection process took almost three months and noted it would be extremely difficult to adequate advertising, screening, interviewing and hiring of one applicant by December 1, a proposed deadline.

Gene Matkowski, a member of the audience and husband of Council Member Geri Matkowski, suggested imposing a deadline could eliminate some good candidates and might encourage the council to rush naming a new administrator.

"As Mr. O'Brien suggested, we were without a village administrator for a year and a half before he came," Matkowski said. "Why are we concerned with deadlines? I think you should take the time now."

Connelly said Milford had followed the same selection procedure proposed by the village; in other words, choosing to have individual council members participate in all phases of the selection

process rather than set up a committee. Several members spoke in favor of setting up a committee, pointing out that it would be impossible to grant confidentiality if the applicant requested it should the full council be involved. Under the Open Meetings Act, the council would have to disclose that information in a public meeting.

But Council Member Geri Matkowski favored screenings by the full council.

"We will all have to work with this administrator," she said. "This is a very important decision. We should all become involved."

She said even if a council member was unable to make a meeting on choosing the new administrator, at least the information would be available.

In discussing qualifications for the

post, the council noted proposed salary should be somewhat less than the approximately \$29,000 O'Brien is paid. Gerhard pointed out that it took O'Brien 10 years to work up to that figure and his replacement should be hired for less, if possible.

The council decided to leave salary a negotiable figure. One of the requirements for the job is village residency within 120 days. Municipal management experience will not be required, but is preferred.

O'Brien had planned to announce his retirement in August, but delayed the announcement because of the resignation of former Council President John McEllan. O'Brien said at that time he would stay on longer to help with the transition between council presidents.

Autumn in Northville

Thursday, Friday and Saturday
October 21, 22 & 23

Stores open Friday 'til 9 and Saturday 'til 6

- Sales in all participating stores
- Hayrides for kids of all ages
Friday starting at 6 p.m. in front of the Marquis Theatre
- Free Cider and Donuts
Saturday from 11-5 served by the Girl Scouts
- Pumpkin Painting Contest
Sponsored by the Kiwanis Club
1-3 Saturday, Main Street Park

Main Street 78

Shoes
Men's & Ladies' Dress & Casuals
Good Selection 1/2 Price
153 E. Main

Little People
20% OFF ALL MERCHANDISE
Except Some Handmade Items
183 E. Main
349-0615

Northville Watch & Clock Shop
UP TO 50% OFF
Grandfather Clocks
Fri. & Sat. Only
132 N. Dunlap
349-4838

Lapham's
Men's Shop
Arrow Flannel Shirts - Jackets
25% OFF
120 E. Main
348-3877

Clare Kelly
Special Sale
All Fall Fashions Reduced
25% OFF
Thurs., Fri., Sat. only
Oct. 21, 22, 23
141 E. Cady
349-9020
9 a.m. to 9 p.m.

IV Seasons
25% Off
• Gifts
• Silks
• Silk Arrangements
Main Street
349-0671

NORTHVILLE CAMERA & HOBBY SHOP
Custom Framing
15% OFF
3 Days Only
105 E. Main St.
349-0105

THE SMARQUIS
Winter Coats, Jackets and Sweaters
20% Off
133 E. Main St.
349-8110

Green's
CREATIVE HOME CENTER
3 Days Only
All Sanitas Books
40% Off
• Peppermint • Crickets • Gingers
107 N. Center
349-7110

Northville Pharmacy
25% OFF
All Vitamins
3 Days Only
134 E. Main
349-0850

Long's
Heavy Park Designer
See what's new for fall...blazing colors!
190 E. Main St.
349-0373

SANDIES HALLMARK SHOPPE
FREE Christmas Card Imprinting on Bowed Hallmark Cards
Valued at \$6.00 and Up.
Envelope Imprinting Extra
124 E. Main
348-0290

freud's
Men's and Ladies Wear
20% off
Storewide
112 & 118 E. Main
349-0777

Main Street Barbers
2.00 off
All Styles
When you mention this ad
168 E. Main
349-2822

Candy Stripe Carpet
\$5.99 Sq. Yd.
145 E. Cady
349-4480

Second Chance Resale Shop
Like-New clothing for men, women, children
Benefit Methodist Children's Home Society
Wed., 12-4:30, Thurs., Fri., Sat. 10-4:30
140 Mary Alexander Ct.
349-2727

BOOKSTALL
ON THE MAIN
Just Arrived!
Beautiful Coffee Table Books
• "The Life of Henry Ford"
• "U of M Scrapbook"
• "Our Family History"
All 1983 Calendars
10% Off
118 E. Main
348-1187

Del's
Department Store
(Formerly Brader's)
Select Group
50% off
141 E. Main

Novi homecoming features parade, floats, fun



Except for the final figures on the scoreboard, just about everyone agreed that Novi's 1983 Homecoming was a success. The senior class took top honors in the float competition (left). And Queen Debi Semaan and King Dave Williams reigned over Homecoming activities. The cast of Godspell showed its Homecoming spirit and announced its upcoming performance at the same time by entering a float in the parade. And a member of the Novi Wildcat marching band even looked like one as she marched along. The only blotch on the record was Novi's 7-0 loss to Lakeland in a key Kensington Valley Conference showdown Friday night. (News photos by Steve Fecht)



Protect Yourself With These High Rates

Guaranteed!

12.00%

ANNUAL INTEREST WHEN OPENED BY OCTOBER 25, 1982
\$500 MINIMUM/42-MONTH MATURITY

Guaranteed!

10.85%

ANNUAL INTEREST WHEN OPENED BY OCTOBER 25, 1982
\$500 MINIMUM/30-MONTH MATURITY

For those who plan to use investment returns for income purposes, longer-term certificates with guaranteed rates offer a sound advantage. Likewise, for the investor who does not want to be concerned with short term fluctuating investments, a high interest-earning 30 or 42 month certificate is the perfect answer. Your deposit of \$500 or more can provide substantial earnings with interest paid quarterly. Rates are set periodically by the bank and the rate at which you open your certificate remains fixed until maturity. There is a substantial interest penalty for early withdrawal from all certificate accounts. So, for your investment protection get these high rates at Security Bank.



A SUBSIDIARY OF SECURITY BANCORP. INC./MEMBER FDIC
Main Office: 41325 Ten Mile Road, Other Novi Offices at
43395 Nine Mile Road, 30880 Beck Road and 45500 Ten Mile Road. Telephone 478-4000



Elect Thomas Giles
KAVANAGH JR.
To Fill Vacancy, Oakland Circuit Judge

Paid for by Kavanagh for Oakland Circuit Judge Committee. 1 Amberly, Pleasant Ridge, MI 48069. See 419

Section B

Wednesday, October 20, 1982

GREEN SHEET

Sliger/Livingston East

Want Ads
INSIDE

'Movieland' home rental business a winner

By ALICE DAVIES

So you like movies? But you never have time? You missed the ones you really wanted to see? Well, in this place you could go crazy.

"Golden Pond," "Quest for Fire," "Star Wars" — they are all there, just waiting for you.

For five dollars you rent a film; for another five you get the VHS (Video Home System) player for a night.

At home, you hook the VHS to your own TV antenna lead, slide the film cassette into the VHS — and that's it. No driving, no babysitter, your favorite chair and maybe even your own popcorn — all of this comes with your home movie rental.

I totally underestimated the market. I was amazed how many people had equipment.

— Bill Wilson
— movie rental business owner

Just think of the possibilities: you can arrange your own "Laurel and Hardy" festival, see "Harold and Maude" for the 17th time, revisit Tara in "Gone with the Wind," relive your first romance with whatever title fills that bill.

"Wizard of Oz" without commercials, "Sound of Music" hooked up to your own stereo for an added dimension in sound — it's all there waiting. Bill Wilson says he opened his movie rental business almost by accident. Also, he admits he is addicted to movies — all kinds of movies.

Barely two years ago, Wilson was working long hours in his TV and stereo repair shop. "I could rarely watch television. One Tuesday night I was into 'Midway,' a great war movie. And then at 11 o'clock, they said it would be continued the following night!" Frustrated, he told his wife he was going to buy a video recorder. That way, he reasoned, "I could watch what I wanted, when I wanted, as many times as I wanted."

Soon Wilson had picked up a number of film cassettes and decided to run an ad in the local paper on rentals. "I totally underestimated the market. I was amazed how many people had their own equipment," Wilson remembers. This fall, with two film rental stores and a third one planned, he has discovered the market is even bigger than he imagined. No more TV and stereo repair. In less



Employee Bonnie Vore and manager Dennis B. enjoy their work and their popcorn

than two years, his "Movieland" business has taken off like a rocket. Two stores, one north of Milford at 1246 Milford Road, another at 811 East Grand River in Brighton, will soon be joined by a third in Waterford.

Here's what Wilson offers his customers:

- no club or membership fees,
- film rental at \$5 for two days,
- VHS machine rental at \$5 per day.

There are deposits, of course, because films and equipment are

valuable. But with a Master Card or Visa, even that is not a problem.

In Milford, store manager "Dennis B." says his customers are not any certain group or type. "Just anybody who enjoys movies for their own personal viewing."

As many as 1,500 films are available through the system, including the original first three episodes of the "Lone Ranger."

all-time favorite. "I'm a sucker for a love story, I like the time-travel idea, and I love the Mackinac Island setting."

"Comedies? I liked 'Arthur,' and 'Golden Pond' has some of the funniest lines I've ever heard," Dennis says. But one of his very favorites, one he never tires of seeing, is Disney's "Dumbo."

Book in advance, Dennis advises. Some films almost always are in demand. Right now, an Arthur Hitchcock festival sounds appealing — something colorful full-length cassette and a big season.

Hot Line open to aid business

B.R.E.E.C.H. — the new Business and Real Estate Expansion and Clearing House of Oakland County, Incorporated, — has a "hot line" to help business.

The number is 644-3895. B.R.E.E.C.H. is a group of highly-skilled business leaders in Oakland County with expertise to help companies with problems or questions about remaining, expanding or relocating in Oakland County, the Oakland County Chamber of Commerce announces.

The "hot-line" will be open Monday through Friday from 9 a.m. to 5 p.m. It is in the chamber office, although B.R.E.E.C.H. is a separate, non-profit corporation made up of volunteers, and funded solely by contributions. The chamber office is at 10 West Huron in Pontiac.

LIT seeks poets

Young William Shakespeares or John Steinbecks are being sought during Lawrence Institute of Technology's high school writing contest open to students of English in the Detroit metropolitan area.

Poetry, short stories or essays may be submitted. First, second and third prizes of \$50, \$20 and \$10 in each category will be awarded.

Deadline for entries is November 19. Winners will be notified by January 14, 1983.

Entries must include a statement from the contestant's high school English faculty confirming originality.

The LIT Humanities department may be contacted for more information.

Take stock in America

Last Week of Sale

Fall into Winter

Low Financing rate 12.8%

Get Attached to a Case Sweeper



Two Stage Design Sweeper with clean sweep of leaves, pine needles, snow, etc. Includes 20" tires, 12" deck, 12" rear roller, 12" front roller, 12" rear roller, 12" front roller, 12" rear roller, 12" front roller.

Reg. \$365.00
Sale \$320

SAVE \$45

10 hp Tractor with Mower and Snow Blade

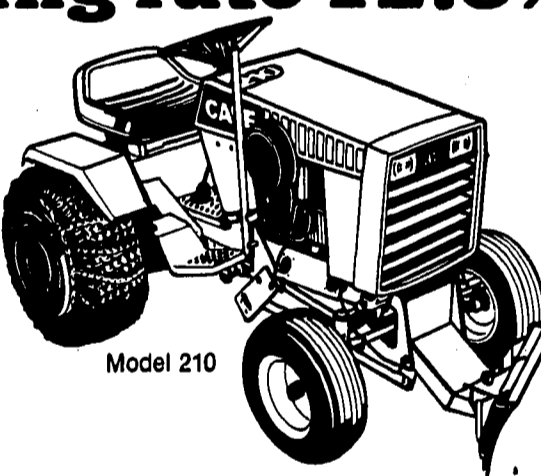

Model 210

SAVE OVER \$700

- 10 H.P. Cast Iron Kohler Engine
- 4 Speed Trans. Cast Iron Rear Axle
- Lights
- 12 Volt Electric Start
- Double Channel Frame
- Weighs 840 Lbs.

Loader



Case Loader/Tractor

Reg. \$5550
Sale \$4250

All hydraulic drive

16 H.P. Tractor



Case Snowblower

Save over \$1150

All Hydraulic drive & lift

All Trade-Ins Accepted

Many used Trade-in Tractors available

NEW HUDSON POWER

Cash & Carry
53535 Grand River at Haas
Mon.-Fri. 9-6
Sat. 9-4
2 miles West of Wixom Rd. **437-1444**

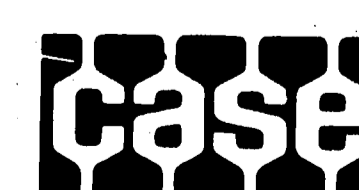

OREGON

OMARK INDUSTRIES O

SAWCHAIN SALE!

Save big on sharp new OREGON cutting chains for chain saws. We're dealer like never before on the world's best. Get a tough new OREGON chain on your chain saw. Then get ready for some easy cutting.

12" Chain	\$9.70
14" Chain	\$10.70
16" Chain	\$11.70
20" Chain	\$12.70
25 Ft. Roll	\$55.00

Super Chisel Chain available At Discount Prices

Ask for a FREE Cash & Carry New Hudson Power

53535 Grand River at Haas
437-1444

ITASCA Quality Chain Saw Oil Sale

Engine Mix	16:1 Oil Mix	\$3.75
Bar & Chain Oil	Reg. \$7.95 Sale	\$3.95

Cash & Carry

New Hudson Power

53535 Grand River at Haas
437-1444

021 Houses For Sale
HAMBURG Township 3 bedroom ranch with basement and attached garage, large lot...

021 Houses For Sale
HAMBURG One bedroom home on two lots, \$60,000 down, land contract...

021 Houses For Sale
HOWELL FARMHOUSE modernized with updates in complete apartment...

021 Houses For Sale
HOWELL Long ranch on acre wooded setting, near Howell City Park...

025 Mobile Homes For Sale
FOWLERVILLE 1982 14x30, 2 bedrooms, 1 1/2 baths, full kitchen...

027 Farms, Acreage
WANTED to rent-huntling rights to harvested corn field for goose hunting...

039 Cemetary Lots For Sale
BRIGHTON Memorial Park 8 lots, \$150 each, (313)865-4772.

061 Houses
HOWELL, Pinckney area, 2 bedrooms, basement, garage, 2 1/2 baths...

064 Apartments For Rent
BRIGHTON, 2 bedrooms, \$245, 2 bedrooms, \$200. Newly decorated, all appliances...

NICHOLS REALTY INC. 348-3044
Do you love the wood trim, the screened porch and the formal dining room of an older home?

REALTY WORLD Van's 4848 E. Grand River, Brighton, MI 48116
RESTORED: BRIGHTON'S OWN HOME and HE SAYS SELL!

4281 MARKS DRIVE NOVI
MILFORD 12x50, 2 bedrooms, in-level on corner terms negotiable...

CRANDALL REALTY (313)466-9999
HOWELL Close to schools, 3 bedrooms, 2 1/2 baths, full kitchen...

BANK REPOSSESSED HOMES
Mobile homes in beautiful location, ready to move and occupy...

ATTENTION HOMEOWNERS
SINGLE FAMILY HOME Accredited Management Organization

ATTENTION HOMEOWNERS
SINGLE FAMILY HOME Accredited Management Organization

ATTENTION HOMEOWNERS
SINGLE FAMILY HOME Accredited Management Organization

ATTENTION HOMEOWNERS
SINGLE FAMILY HOME Accredited Management Organization

COUNTRY IN THE CITY—3 car garage brick fireplace with warm finished basement...

RESTORE THIS OLDER FARM HOME and be the envy of historical home lovers!

FAIRWAY TRAILS in Brighton
The "TODAY" New Cape Cod style home with 3 bedrooms and expandable 2nd floor...

GLOBAL MOBILE HOMES INC.
Mobile homes in beautiful location, ready to move and occupy...

GLOBAL MOBILE HOMES INC.
Mobile homes in beautiful location, ready to move and occupy...

GLOBAL MOBILE HOMES INC.
Mobile homes in beautiful location, ready to move and occupy...

GLOBAL MOBILE HOMES INC.
Mobile homes in beautiful location, ready to move and occupy...

GLOBAL MOBILE HOMES INC.
Mobile homes in beautiful location, ready to move and occupy...

GLOBAL MOBILE HOMES INC.
Mobile homes in beautiful location, ready to move and occupy...

Century 21 349-1212
SUBURBAN REALTORS 361-1823

RESTORE THIS OLDER FARM HOME and be the envy of historical home lovers!

GLOBAL MOBILE HOMES INC.
Mobile homes in beautiful location, ready to move and occupy...

GLOBAL MOBILE HOMES INC.
Mobile homes in beautiful location, ready to move and occupy...

GLOBAL MOBILE HOMES INC.
Mobile homes in beautiful location, ready to move and occupy...

GLOBAL MOBILE HOMES INC.
Mobile homes in beautiful location, ready to move and occupy...

GLOBAL MOBILE HOMES INC.
Mobile homes in beautiful location, ready to move and occupy...

GLOBAL MOBILE HOMES INC.
Mobile homes in beautiful location, ready to move and occupy...

GLOBAL MOBILE HOMES INC.
Mobile homes in beautiful location, ready to move and occupy...

NORTHVILLE COMMONS ranch of three large bedrooms, two one-half baths, formal dining room...

NORTHVILLE MALLING, minutes to town and X-ways. This spacious and spotless split level home...

UNUSUAL! 2 floor home with formal and kitchen, over 1000 sq. ft. living room...

VETS- BUY NOW! RATES DOWN- 12% SEVERAL HOME S RANGES- ALL PRICE RANGES!

WEATHERVILLE 3 bedroom home, 2 baths, fireplace, separate garage, \$35,900.

WEATHERVILLE 3 bedroom home, 2 baths, fireplace, separate garage, \$35,900.

WEATHERVILLE 3 bedroom home, 2 baths, fireplace, separate garage, \$35,900.

WEATHERVILLE 3 bedroom home, 2 baths, fireplace, separate garage, \$35,900.

WEATHERVILLE 3 bedroom home, 2 baths, fireplace, separate garage, \$35,900.

WOODLAKE VILLAGE BRIGHTON LIQUIDATION SALE
REDUCED OVER 40% BUY ONE NOW FOR \$8,990 AVAILABLE NEW HOMES—REDUCED 25%!

WOODLAKE VILLAGE BRIGHTON LIQUIDATION SALE
REDUCED OVER 40% BUY ONE NOW FOR \$8,990 AVAILABLE NEW HOMES—REDUCED 25%!

WOODLAKE VILLAGE BRIGHTON LIQUIDATION SALE
REDUCED OVER 40% BUY ONE NOW FOR \$8,990 AVAILABLE NEW HOMES—REDUCED 25%!

WOODLAKE VILLAGE BRIGHTON LIQUIDATION SALE
REDUCED OVER 40% BUY ONE NOW FOR \$8,990 AVAILABLE NEW HOMES—REDUCED 25%!

WOODLAKE VILLAGE BRIGHTON LIQUIDATION SALE
REDUCED OVER 40% BUY ONE NOW FOR \$8,990 AVAILABLE NEW HOMES—REDUCED 25%!

WOODLAKE VILLAGE BRIGHTON LIQUIDATION SALE
REDUCED OVER 40% BUY ONE NOW FOR \$8,990 AVAILABLE NEW HOMES—REDUCED 25%!

WOODLAKE VILLAGE BRIGHTON LIQUIDATION SALE
REDUCED OVER 40% BUY ONE NOW FOR \$8,990 AVAILABLE NEW HOMES—REDUCED 25%!

WOODLAKE VILLAGE BRIGHTON LIQUIDATION SALE
REDUCED OVER 40% BUY ONE NOW FOR \$8,990 AVAILABLE NEW HOMES—REDUCED 25%!

WOODLAKE VILLAGE BRIGHTON LIQUIDATION SALE
REDUCED OVER 40% BUY ONE NOW FOR \$8,990 AVAILABLE NEW HOMES—REDUCED 25%!

ATTENTION!!! INVESTORS BUILDERS HOME BUYERS
WOODLAKE VILLAGE BRIGHTON LIQUIDATION SALE

ATTENTION!!! INVESTORS BUILDERS HOME BUYERS
WOODLAKE VILLAGE BRIGHTON LIQUIDATION SALE

ATTENTION!!! INVESTORS BUILDERS HOME BUYERS
WOODLAKE VILLAGE BRIGHTON LIQUIDATION SALE

ATTENTION!!! INVESTORS BUILDERS HOME BUYERS
WOODLAKE VILLAGE BRIGHTON LIQUIDATION SALE

ATTENTION!!! INVESTORS BUILDERS HOME BUYERS
WOODLAKE VILLAGE BRIGHTON LIQUIDATION SALE

ATTENTION!!! INVESTORS BUILDERS HOME BUYERS
WOODLAKE VILLAGE BRIGHTON LIQUIDATION SALE

ATTENTION!!! INVESTORS BUILDERS HOME BUYERS
WOODLAKE VILLAGE BRIGHTON LIQUIDATION SALE

ATTENTION!!! INVESTORS BUILDERS HOME BUYERS
WOODLAKE VILLAGE BRIGHTON LIQUIDATION SALE

ATTENTION!!! INVESTORS BUILDERS HOME BUYERS
WOODLAKE VILLAGE BRIGHTON LIQUIDATION SALE

CHEAP HEAT! OPEN SUNDAY 2-5 p.m.
OMEGA HOMES

CHEAP HEAT! OPEN SUNDAY 2-5 p.m.
OMEGA HOMES

CHEAP HEAT! OPEN SUNDAY 2-5 p.m.
OMEGA HOMES

CHEAP HEAT! OPEN SUNDAY 2-5 p.m.
OMEGA HOMES

CHEAP HEAT! OPEN SUNDAY 2-5 p.m.
OMEGA HOMES

CHEAP HEAT! OPEN SUNDAY 2-5 p.m.
OMEGA HOMES

CHEAP HEAT! OPEN SUNDAY 2-5 p.m.
OMEGA HOMES

CHEAP HEAT! OPEN SUNDAY 2-5 p.m.
OMEGA HOMES

CHEAP HEAT! OPEN SUNDAY 2-5 p.m.
OMEGA HOMES

OMEGA HOMES
This home is heated and cooled with a Ground Water Heat Pump...

OMEGA HOMES
This home is heated and cooled with a Ground Water Heat Pump...

OMEGA HOMES
This home is heated and cooled with a Ground Water Heat Pump...

OMEGA HOMES
This home is heated and cooled with a Ground Water Heat Pump...

OMEGA HOMES
This home is heated and cooled with a Ground Water Heat Pump...

OMEGA HOMES
This home is heated and cooled with a Ground Water Heat Pump...

OMEGA HOMES
This home is heated and cooled with a Ground Water Heat Pump...

OMEGA HOMES
This home is heated and cooled with a Ground Water Heat Pump...

OMEGA HOMES
This home is heated and cooled with a Ground Water Heat Pump...

OMEGA HOMES
Building line homes for fine families...

OMEGA HOMES
Building line homes for fine families...

OMEGA HOMES
Building line homes for fine families...

OMEGA HOMES
Building line homes for fine families...

OMEGA HOMES
Building line homes for fine families...

OMEGA HOMES
Building line homes for fine families...

OMEGA HOMES
Building line homes for fine families...

OMEGA HOMES
Building line homes for fine families...

OMEGA HOMES
Building line homes for fine families...

ASK THE LAWYER

Questions? Write to Attorney Larry Korn, care of Sliger-Livingston Publications, Post Office Box 160, Northville, Michigan 48167. Questions will be answered on a space-available basis. Answers in this column are directed at specific facts and may not apply in all situations.

Q. My boyfriend and I lived together for over five years. We bought a house and the title of the house shows that we own the property as husband and wife. My boyfriend died. We both intended that if he died I would get the house and if I died, he would get the house. Will I get the house if the deed shows that I am his wife even though we were not married?

A. Although you and your boyfriend lived together for five years, you are not husband and wife. Michigan is not a common law marriage state. In Michigan, in order to be married, you must have a marriage license and a civil ceremony.

If the deed to the house showed that you got title to the house as joint tenant with full rights of survivorship, survivor take all, and not as tenants in common, you would have been entitled to receive the title to the house as the survivor with joint tenancy.

However, I doubt that any right of survivorship would exist in a tenancy by the entirety where you were not married and no words otherwise expressed the right of survivorship.

Q. I have loaned some money to my granddaughter and her husband. Her husband now wants a divorce. His name is on the paper that he signed when we collect my loan as I am a retiree and could really use the money that my granddaughter and her husband owe me.

The judge will give you a judgment for the money that is owed to you and you will undoubtedly have to garnish their paycheck or execute their assets if they do not pay you.

A. If your granddaughter and her husband owe you \$600 or less, you should file suit in the district court in the city where your granddaughter and her husband reside. Sue both your granddaughter and her husband. If they owe you over \$600, I would suggest you retain an attorney and start suit in district court for a money judgment as quickly as possible.



Kiss Your Newspaper Carrier

(In Celebration of International Newspaper Carrier Day)



We are proud of the many young men and women who deliver our newspapers to you each week!

Sliger/Livingston Publications Inc.

Brighton Argus • Fowlerville Review • Hartland Herald
Livingston County Press • Milford Times • Northville Record
Novi/Walled Lake News • Pinckney Post • South Lyon Herald

Sports

NOVI-WALLED LAKE NEWS

Wednesday, October 20, 1982

Novi cagers eye title	2
Vikings fall to Harrison	3
Windsor runner wins race	4

Wildcats stunned by late Lakeland bomb

By JEFF FRANK

Novi was regarded as the passing game, but somebody mixed up the flight plans Friday as Air Osborne was grounded by some heavy turbulence from the Lakeland defense and the Eagles used the pass to take a 7-0 victory in the KVC battle of unbeaten.

Doug Woods made a sensational grab back Eric Deline completed just five of

15 attempts. "They have a great defense," said Wildcat coach John Osborne. "They caused numerous turnovers and made big plays."

The biggest play came late in the game. On third and seven from the Eagle 47, St. John rolled left and fired downfield to Woods.

Deline got a hand on the ball, but Woods was able to make a brilliant, juggling catch and then raced into the end zone for the game's only touchdown and a 7-0 Lakeland victory.

Meanwhile, Novi was being held without a first down through the third quarter. The Cats finally got moving midway through the fourth quarter when a personal foul brought them near midfield and Deline hit Dave Williams for 24 yards to the Lakeland 29.

A Rich Sinda dive gained four more, but Novi fumbled on the next play and the Eagles recovered to thwart the threat.

Neither team threatened in the first half. Lakeland stuck to the ground, but had little success against the Wildcat defense which dropped Eagle runners for losses eight times.

Novi had even less success, suffering three pass interceptions on its first four possessions as Lakeland gained field advantage. Fortunately, Deline's punts, including a 46-yard boomer to the Lakeland 1, kept the Eagles out of Novi territory.

Lakeland unveiled its passing game in the second half. Novi fumbled the opening kickoff and the Eagles recovered on the Wildcat 31.

St. John hit Woods for 24 yards to the Novi 4, but the Wildcat defense held fast and a 23-yard field goal attempt sailed wide.

Lakeland threatened again on its next possession, again moving to the four before Novi stiffened and another field goal attempt missed the target.

Lakeland also has a 4-1 record in the KVC this fall.

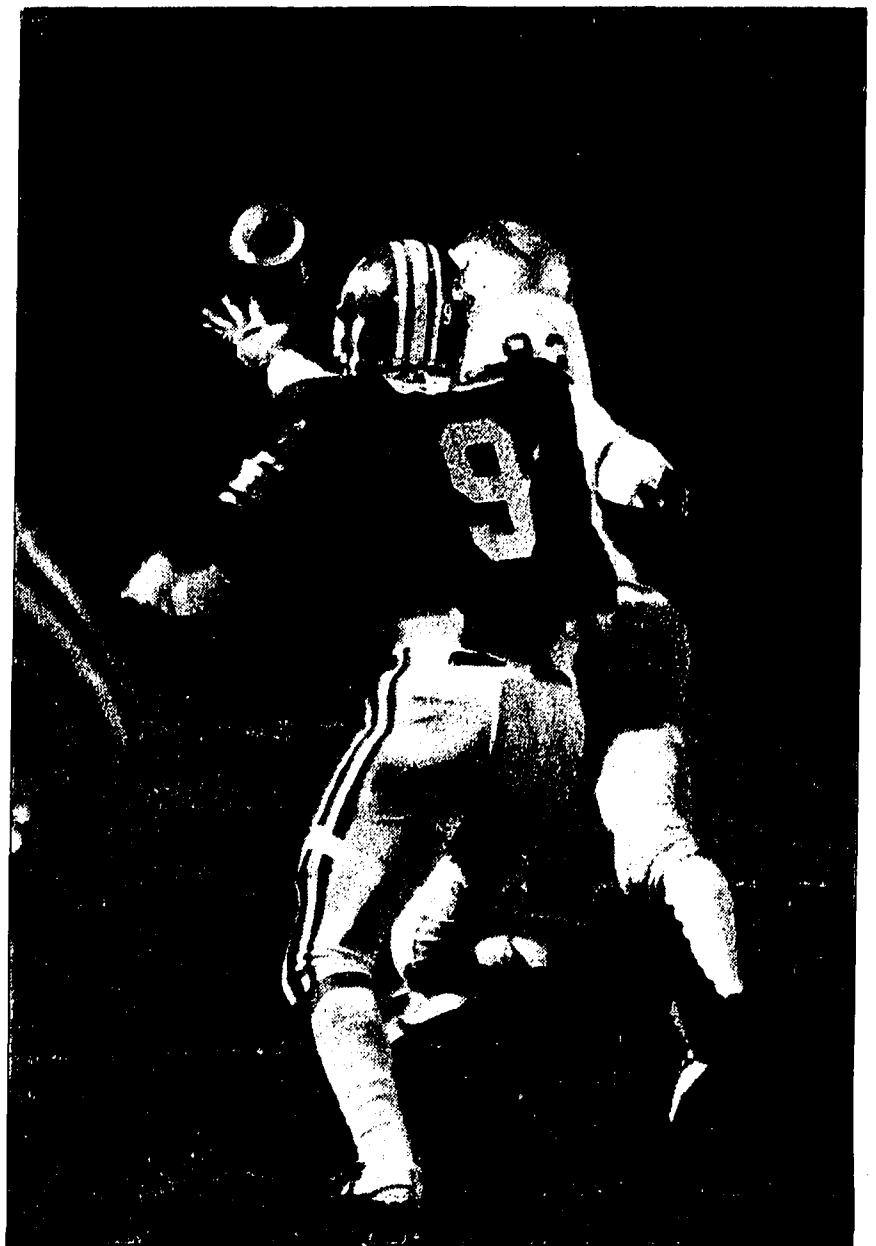

Eric Deline (9) tips the ball but Lakeland's Doug Woods makes a juggling catch and races into the end zone for the winning touchdown

Canton's aerials thwart Western

"They played their best game of the season and we played our poorest." That's how Head Coach Chuck Apap summed up Walled Lake Western's 27-3 loss to Plymouth Canton last week.

After giving up just 26 points in the first four games of the season, the usually stalwart Warrior defense was riddled by an aerial attack led by the Chief's Pat Murphy who hit 11 of 16 attempts for 176 yards and three touchdowns. Canton also scored its fourth touchdown through the air.

The Warriors scored their only points when Paul Imms booted a 34-yard field goal in the third quarter.

"It was just one of those things," commented an obviously-depressed Apap after the game. "Canton played its best game of the season and we played our poorest. They just didn't make any mistakes."

"Their quarterback had a fantastic day. He completed almost everything he threw; he just couldn't miss."

Apap said two events in the first half were critical to the outcome of the game. Canton opened the scoring when Murphy hit Bob Waszczenki from 19 yards out in the first quarter to take a 7-0 lead.

Western then marched down to the Chief 20 and apparently had picked up a first down on a Dave Meyer to Aldo Buttazzoni pass that carried to the two, only to have the play nullified by a clipping penalty. A subsequent field goal attempt was missed.

Canton upped the score to 14-0 at the half by marching 62 yards in the last 90 seconds, scoring on a two-yard pass from Murphy to Ron Rienas as time ran out.

"Those two things — the penalty and the last-second touchdown — really hurt us," observed Apap. "It would have been a totally different ball game if we had scored that touchdown, and there's no way they should be able to go 62 yards with just 50 seconds left in the half."

Western had one more chance to get back in the game in the third quarter. Frank Garbick intercepted a Murphy pass on the Chief 23, and Paul Imms then carried five straight times down to the two. But quarterback Rick Hunter was sacked for a 15 yard loss on a key third down play and Western had to settle for a field goal.

Canton upped its lead to 20-3 shortly thereafter as Murphy completed a 49-yard bomb to Waszczenki. The Chiefs made the final score 27-3 by scoring on another 19-yard pass late in the fourth quarter.

Both Canton and Western finished the game with nine first downs, but the Chiefs picked up 279 total yards in comparison with 164 for the Warriors. Western gained 164 yards on the ground while limiting the Chiefs to 103 rushing yards, but the big difference came in the air as Canton hit 11 of 16 passes for 176 yards while Western failed to complete any of its six passing attempts.

Imms again sparked the Warrior offense, gaining 103 yards on 20 carries. Apap also praised the offensive contributions of tight end Aldo Buttazzoni and tackle Ron Wendland. Defensively, the Warrior coach singled out linebacker Todd Coulter, safety Mickey Folsom and noseguards Matt King and Mark Johnson for praise.

"It was an awfully disappointing game to lose, but I discovered one thing," said Apap, "the sun came up again Saturday morning."

SPECIAL SAVINGS SALE



A Beautiful Store with Beautiful Furniture
America's most distinguished traditional furniture
Colonial House
20292 Middlebelt Rd. (South of Eight Mile)
Livonia
Open Mon., Thurs. & Fri. 11-9 P.M., Sunday 1-5 P.M. • 474-6800

ANTIQUE CLOCKS

Sales & Repairs
NORTHVILLE
Watch & Clock Shop
132 W DUNLAP
NORTHVILLE
349-4839

Photo Event SHOW & SALE
OCTOBER 22-23

KODAK DISC 4000 Camera
with 200 film, 28mm lens, 35mm viewfinder, 28mm lens, 35mm viewfinder, 28mm lens, 35mm viewfinder.

LIVONIA - 35555 PLYMOUTH ROAD
Just West of Wayne Road
525-4110

Look Open Golf Everyday

FALL SPECIALS Monday thru Friday

Golf 9 Holes with breakfast	\$6.50	Golf 9 Holes with lunch	\$6.50
Golf 9 Holes with N.Y. Strip Steak	\$11.50	Golf 9 Holes with 2 people with car	\$13.00

Pebble Creek Golf Club and Restaurant
Corner 10 Mile & Currie Bays • Wine • Liquor
South Lyon 437-5411 Open 7 A.M.

If you don't smoke...

Farmers can insure your home or apartment for less

For years, Farmers has been helping non-smokers save money on life and auto insurance, with special policies that give better risks a better deal.

Now non-smokers can save on complete Homeowners packages or on fire coverage alone — available whether you own a house or condominium or rent.

If no one in your home has smoked in two years, you may qualify.

Find out from a fast, fair, and free Farmers Agent:

Jim Storm
43320 W. 7 Mile
Northville
349-6810

FARMERS GROUP

ANTHONY'S

NOW APPEARING
The Return Of
RUMPLESTILTSKIN
Happy Hour Monday thru Friday
5 p.m. to 8 p.m.

Co-Sponsors of U of M Football
on WWJ Radio
Monday Night Football Party
Wide Screen TV

Sheraton-Oaks

THE HARTLAND HOTEL & INN, WALLED LAKE
HARTLAND, MICHIGAN 48333

Special Offer: The Sheraton-Oaks, MI!

Waldenwoods CHICKEN DINNERS

Home Style \$6.95
SECOND HELPINGS ARE ON US!

ENJOY HOME COOKED DINNERS SERVED FAMILY STYLE IN A BEAUTIFUL WOODED SETTING OVERLOOKING LAKE WALDEN.

FAMILY OWNED AND OPERATED FOR OVER FIFTY YEARS

HOURS
FRI. SAT. 5 - 10 PM
SUNDAY 12 - 5 PM
COCKTAILS ARE AVAILABLE
(313) 632-7304

Map showing location of Waldenwoods near Hartland and Livonia.

Show this ad and get \$1.00 off each meal in your group

Novi seeking donors for community blood drive

The annual Novi Community Blood Bank will be held at Holy Family Church on Meadowbrook Road next Tuesday from 1-7 p.m. Chairman Gerry Stipp can be reached at 349-4300 for appointments.

Donors must be 17-65 years old and weigh at least 110 pounds. The procedure takes about 45 minutes from registration through post-donation refreshments.

Now on display in the library is a beautiful collection of glass baskets from the Michigan Depression Glass Club. Also on display is Sheila McCarty's collection of china animals.

Novi Highlights

By Jeanne Clarke
624-0173

More than 75 children participated in the Design-A-Plate program and will receive their plates before Christmas. Registrations are now being taken for the story hour scheduled for every Wednesday beginning November 3. The programs will run 45 minutes long either at 10:30 a.m. or 1 p.m.

Now on display in the library is a beautiful collection of glass baskets from the Michigan Depression Glass Club. Also on display is Sheila McCarty's collection of china animals.

first items displayed in the museum. The group would also welcome its new members: Mayor and Mrs. Bob Schmid and Mr. and Mrs. Pete Romanow and their daughter, Ann Marie.

NOVI ROTARY: Top prize in Rotary's annual raffle is a 1983 Chevrolet or \$7,000 in cash. Tickets cost \$150 and only 110 tickets are available.

NOVI ROTARY: Top prize in Rotary's annual raffle is a 1983 Chevrolet or \$7,000 in cash. Tickets cost \$150 and only 110 tickets are available.

The Cougars are coach by Nick Valent and Russ Abate. Any boys under 14 years old interested in playing games will be held November 4 in a traveling league team in the Spring.

PERSONALS: Mr. and Mrs. Tom Hesse announce the birth of their fifth child, Sarah Elizabeth, born September 21 at Providence Hospital and weighed seven pounds, 12 ounces.

PERSONALS: Mr. and Mrs. Tom Hesse announce the birth of their fifth child, Sarah Elizabeth, born September 21 at Providence Hospital and weighed seven pounds, 12 ounces.

Count Scary visits haunted house

WDIV's County Scary and the Fabulous Monster Band will headline the entertainment this Sunday at the Walled Lake Jayettes Haunted House from 7-9 p.m.

ADMISSION: \$1 for children under 12 and \$2 for adults. There will be a refreshment stand and continuous horror film classics shown to those in the waiting line.

Community Notes

WEST BLOOMFIELD LIBRARY: The Hand Puppeteers will present a "bewitching" Halloween program for children ages four through eight Monday, October 25, at the West Bloomfield Library.

CHILDREN'S WORLD: Living Lord Children's World Day Care Center, 4070 Ten Mile, is sponsoring a Child Care food program. This program is designed to provide meals to children in child care centers, outside school hours, and family care homes.

LEARN HOW TO SAVE A LIFE!



As a community service, Botsford General Hospital will be offering a free training program for area citizens in cardiopulmonary resuscitation (CPR). The ultimate purpose is to enable citizens to perform CPR for heart attack victims until emergency medical personnel arrive.

Roethel steps down from presidency

Romaine Roethel has passed the badge of authority as national president of the American Legion Auxiliary to June Stolle of Missouri.

Wedding bells to ring

Mr. and Mrs. Paul F. Heinke of Walled Lake announce the engagement of their daughter, Lara Kay, to Philip Richardson of Bloomfield Hills.

Choral groups slate concert

The Novi Choralaires will join choral groups from three communities to present a special concert at Novi High School's Furst Auditorium this Sunday.

Artists exhibit at annual fair

Area residents will have an opportunity to see the work of numerous local artists and craftsmen at the 1982 Novi Arts and Crafts Fair.

SAVING FOR THE HOLIDAYS CAN BE A BEAR.



You've heard the saying, "Christmas comes but once a year." Well, for people with a stack of bills to pay in January, once is quite enough.

Open a Christmas Club account at First Federal of Michigan today. Next year you'll get many happy returns.

McCall
For State Representative
Bob McCall
Attorney at Law
-16 Years Experience - Michigan
Public Service
-Former Civil and County Prosecutor's Economic Crime Division
-Former Chair, Wayne County Council
-Veteran
-U.S. Army Security Agency
-Endorsed
-Michigan Education Association
-Michigan Education Association
-Michigan Education Association

PIZZA STATION
DOWNTOWN NORTHVILLE
340 NORTH CENTER
FOR THE BEST PIZZA
AROUND OR SQUARE
CALL 348-3333
Open 11 a.m. Tues. - Sat.
4 p.m. Sunday, Closed Monday

Large Pizza
(16" 10 pieces)
with cheese & 1 item
Only \$5.49
with coupon only
Plus Tax
Our Famous Round Or Deep Dish Square, Cheese And Any One Item Of Your Choice.
(Each additional item 75¢ with this coupon)
Pick Up Only
offer expires Nov. 15, 1982
Compare their coupon price with our regular price

Green's CREATIVE HOME CENTER
107 N. Center (Sheldon Rd.)
Northville - 349-7110
Hours: Mon. 9-5, Tues. 9-5, Wed., Thurs., Fri. 9-5, Sat. 10-5, Sun. 10-5

685 COLORS ON SALE
APRIL ANGEL GREEN PALE LIME MAY LIMBO CELERY
LIME TROPIC OIL VINE FIRE JAZZ
WINE FALLO WHITE WINE FALLO WHITE
COCONUT MALT CHOCOLATE LIME LIME
LIME LIME WINE ORIOLE HIGGLE
WING WING BRUS MUSHY
MUSHY GENT GENT COCO
COCO HILL HILL BR
BR RON RON BLUE SILV
SILV SILVER BEEL COVE GRAY
GRAY ENGLISH GRAY VINEYARD
VINEYARD MERCURY DOCUMENT
DOCUMENT BLU CORNFLOWER
BLUE BLAZER ARIEL BLUE SUDEDE
CAS BUTTERFLY BLUE BENTON
BENTON COLOR ARABIAN BIRD
LONDON GRAY SURF FORTUNA
FORTUNA PALISADE ICE CAP
MIS CELESTIAL BLUE AZURE
BLUE WATERSIDE BLUE LILLYPUP
PINK CREAM BEAN AURORA
ARBUSUL SWIRL LADY PINK
RUFF ORCHID PINK LEM MARSH
ROSE OCEAN SAND ROMAN
BEIGE TASCAN SILVER LILAC
MEMORIES HUSHBABY FROU-FROU
SH LEGEND BIRDSONG
CONSTANCE FLORA DEEP SPL WOOD
AND MIST EYE TIMID ANGEL
WING FANCIU PINK LUSI
PINK PINK LUSTRE CHERIO
LA FLOR EYE GERANIUM
GOLDEN ROSE ROSE TREE
MIO PURPLE CAREFREE
EVENSONG FOLIES HIGH SOCIETY
CHARM PALE BLUE PADID
DEERBERRY LEMON SWISSI MIRAGE
FREE SPIRIT FRAGILE MARGUERITE
FRENCH AMBER WHITE
YELLOW JEWEL JENSEN GOLD
JEWEL WHEAT BRITE
YELLOW BLEACHED WOOD
FLAX CLAR CLOUT FLASH
MASCOT SAHARA NEW WORTHER
LOW MAGELLAN SHERRY
FIELD YELLOW RICH CREAM BONE
IVORY CORN HUSK BOLD CANE
PERFECT GOLD YELLOW GOLDEN
MARE PERRY GOLD KINGS AND ORCHID
WHEATSTRAW PERFECT YELLOW
LEMON YEL LEMIN SPICE
LEMONHONEY VEGAN NEW WHEAT
MOONRISE COSSAMER APPLE BLOSSOM
TINT PEARFAT PINK FOAM HOPE
CUTLASS SANDUNE GREEN TURQUOISE
TOLU BLUE CELESTE PLACID
SEA CRYSTAL BELL LYRIC PEP SEA
ISLAND BLUE MARGUERITE
MIST LOST TRADER AMBITIOUS
MARGUERITE SWAN LAKE
COOL FOUNTAIN NEW WOR BUTHE
SPIRIT ARAUCARIA BLUE SURF
PRELLID BREATH SEA ISLE
SEA MORNING MIST WATER BLUE SLEEPY
HOLLOW WILLOW FRODO
COOL COLLIE SPRING WHITE CLASSIC
SPIN NEW DOVE SOAPSTON
HAZZER BRIGON FEATHER ROCK
P GRANADA ROSE FRINGED
FALLO COTTONWOOD P MISSISSIPPI
BROWN BARELY BROWN

Artists exhibit at annual fair
Area residents will have an opportunity to see the work of numerous local artists and craftsmen at the 1982 Novi Arts and Crafts Fair.

Why Pay More?
20\$11.95
COLOR PORTRAITS
TWO 8x10, THREE 5x7, 15 WALLET SIZE
Choice of backgrounds. Finished portraits delivered at store (poses our selection). Additional portraits available at reasonable prices. Minors must be accompanied by parent or guardian. Always friendly, professional service.
BABIES • CHILDREN • ADULTS • FAMILIES

TG&Y family centers
2 Days Only!
Friday & Saturday, Oct. 22 & 23
Daily and Sat. 10-8
42435 W. Seven Mile - Northville
41800 Ten Mile - Novi

JCPenney Correction
There is an error on page 39 of our Fall Sale Break book that ran in today's paper. The prices should have read...
22" underset carry-on luggage, Reg. 16.99 Sale 11.99
Garment bag, Reg. 21.99 Sale 15.99
Luggage rack, Reg. \$15 Sale 10.50
Sorry for these errors.

Morning & Afternoon League Times Available
Available Call after 1 p.m.
Pebble Creek Golf Club
Corner of 10 Mile & Currie Pkds.
Beer • Wine • Liquor
South Lyon 437-6411 Open 7 a.m.

Maybe We're Not Magicians...
...but we do have some nifty little tricks for getting clothes sprung up. Takes experience like ours.
Freydl's
112 E. MAIN NORTHVILLE
349-0777

Tell me about your high gas heating bills
and I'll tell you how you can save up to 20%* with Ameri-Therm.

Ameri-Therm
AMERICAN METAL PRODUCTS CO.
Vent Dampers
Proven in millions of locations
Saves up to 20%* on fuel bills
Popular choice of American homeowners
Five year limited warranty
Thermally actuated to operate efficiently with no wires, electricity, or other power source
Eligible for 15% tax credit.
Available for gas furnaces, boilers and water heaters.

WHY PAY MORE?
20\$11.95
COLOR PORTRAITS
TWO 8x10, THREE 5x7, 15 WALLET SIZE
Choice of backgrounds. Finished portraits delivered at store (poses our selection). Additional portraits available at reasonable prices. Minors must be accompanied by parent or guardian. Always friendly, professional service.
BABIES • CHILDREN • ADULTS • FAMILIES

CALL YOUR NEAREST AUTHORIZED AMERI-THERM DEALER.

CANTON	PLYMOUTH	WALLED LAKE
Paragon Htg. 459-0017	Keeth Htg. & A/C 453-3000	C & P Htg. 669-2600
DRAYTON PLAINS	KEEGO HARBOR	UNION LAKE
Brinker's Pblg. & Htg. 673-2132	Otto A. Trzos Co., Inc. 682-3100	Commerce Htg. 360-2156
Drayton Htg. 673-2379	Cassey's Pblg. & Htg. 682-4508	Mulligan Htg. 698-9700
HIGHLAND	LIVONIA	SOUTH LYON
Duquet & Sons A/C & Htg. 887-5513	Erv Ehlers Co. 538-4900	Max Gates Htg. 437-1558
TAYLOR	John's Htg. 591-1282	
R & L Htg. & Cig. 292-8412	Thomason Htg. & A/C 946-9914	

Here comes
BRIGHT

A fresh new taste experience
that outshines menthol.

It not only tastes fresher while you smoke.
It even leaves you with a clean, fresh taste.

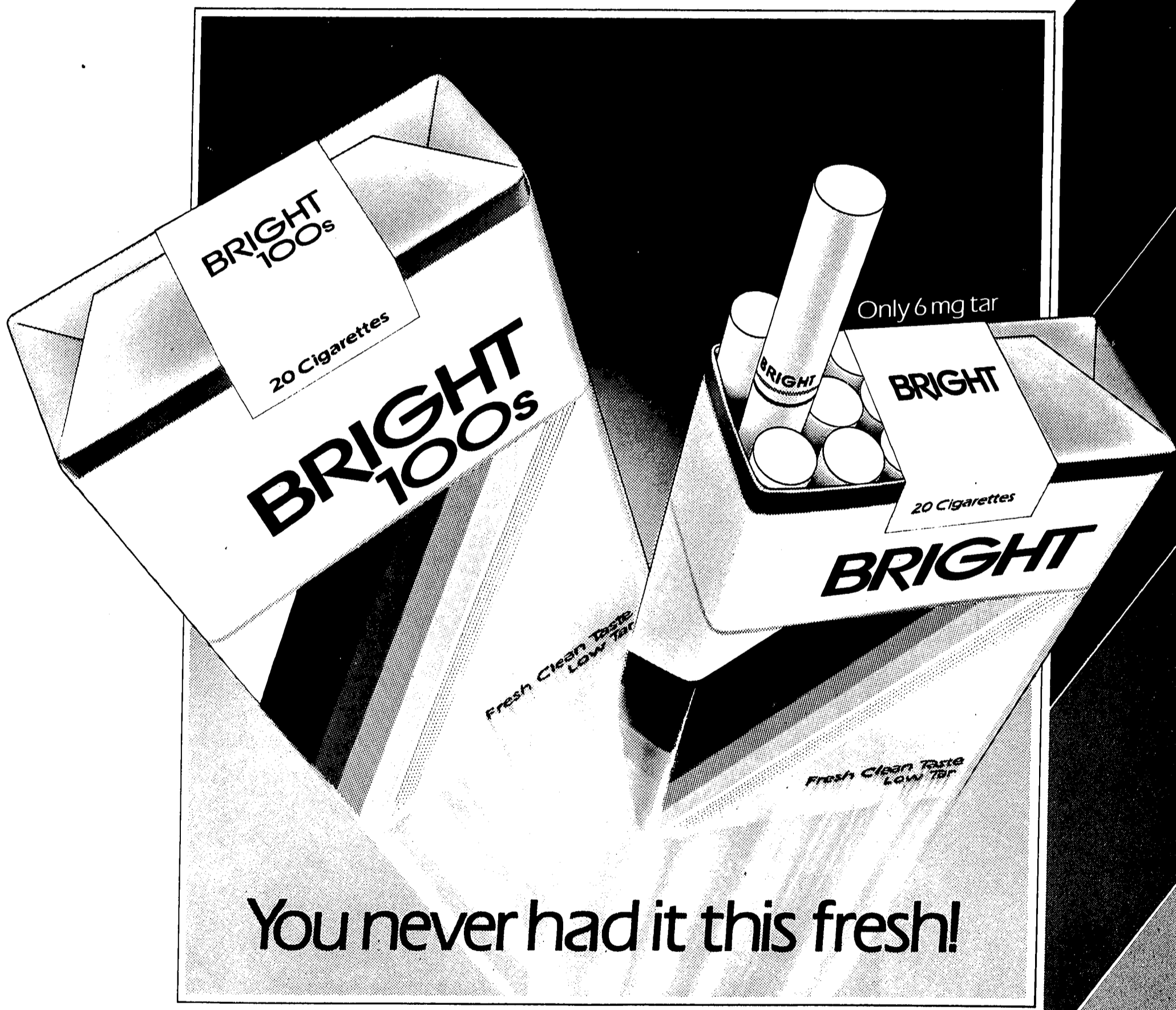

Available in limited areas.

6 mg. "tar", 0.5 mg. nicotine av.
per cigarette by FTC method.

Warning: The Surgeon General Has Determined
That Cigarette Smoking Is Dangerous to Your Health.



Your Area Merchants
are making it easy to find
many of the Best Buys

**Every Merchant
Will Be Slicing Price Tags
On Selected Merchandise
Up To 50% And More.**

Off
AND
MORE

SPECIALS

**AVAILABLE FROM EVERY MERCHANT
IN THIS SPECIAL SECTION**



A Supplement to
**Siger/Livingston
Publications, Inc.**

• Northville Record
• Walled Lake/Novi News

• South Lyon Herald
• Milford Times

October 20, 1982

Step into the Total Bathing Experience

We invite you to visit and browse our 10 coordinated display rooms for your decorating or improvement ideas.

Choose from Exquisite Selections...

- Colorful towels, bathrugs and carpeting
- Medicine cabinets and mirrors
- Fancy faucets, vanity cabinets and tops
- Decorator toilet seats & bath scales
- Shower curtains • Hampers • Soaps
- Decorative wall & counter accessories in metal, wood, ceramic & lucite

"Everyday low prices are comparable to other stores' Sale Prices"

Long's
Fancy Bath Boutique

Division of Long Plumbing Co.

190 E. Main St. Northville 349-0373

Mon.-Thurs. 9-5:30
Fri. 9-9; Sat. 9-5

SELECTED GROUP OF Shower Curtains
1/2 OFF Original Price

La Petite Mini-Blinds

50% OFF

Sale ends October 30, 1982

In business since 1957

Green's
CREATIVE HOME CENTER

107 N. Center St. (Sheldon Road)
Northville • 349-7110

New Hours: Mon., Wed., Fri. 8:30-8;
Tues., Thurs., 8:30-6; Sat. 9-5

VISA

After you "click it"... print it!

FREE

TWO COLOR PRINTS FOR THE PRICE OF ONE

ORIGINAL COLOR ROLL FILM ONLY • NO REPRINT ORDERS
BRING IN A ROLL OF COLOR FILM AND RECEIVE A SECOND SET OF PRINTS AT NO EXTRA CHARGE.

Offer expires Oct. 28, 1982

Processing by **Linprints**
Excludes System 35

Open Daily 9-7; Sat. 9-5; Sun. 9-1

NORTHVILLE PHARMACY
"Pharmacy First Since 1872"
We carry Hollister Ointment Products

134 E. Main St. • Northville • 349-0850
COUPON MUST ACCOMPANY ORDER

Special Offering
SOLID BRASS Pharmacy Lamps
by Remington

Reg. Value \$199.00
NOW \$99
While 24 last

Distinctively handcrafted solid brass pharmacy lamps featuring adjustable arms and a full range dimmer socket for desired light intensity. Solid Antique Brass

Schrader's
Home Furnishings
"Quality Furnishings since 1907"

Mon.-Tues.-Sat. 9 to 6; Thurs. & Fri. 9 to 9; Closed Wednesday
111 N. Center (Sheldon) Northville 349-1838

Del's We Invite You to Compare Our Price & Quality

We're Slicing Prices On Our Complete Selection
(Including All New Fall Arrivals)
Here are just a few of the exciting styles!
Prices good thru October, 1982

All Ladies' Dress & Casual Winter Boots 30% Off

Janet Suede Leather Reg. \$49.00
Rachel Suede Leather Reg. \$59.00
Caryn Reg. \$69.00
May Reg. \$48.00
Irene Suede Leather Reg. \$79.00

Choose from Rust, Wine, Navy, Black, Tan & more.

Men's & Women's Dress & Casuals 1/2 PRICE
Good Selection
STOREWIDE SAVINGS START AT 20%

Women's Dress

Natalie Reg. \$49.00 **30% off**
Livia Reg. \$46.00 **40% off**
Good choice of colors

Regina Reg. \$43.00 **40% off**
Nydia Reg. \$49.00 **20% off**

Women's Casuals

Kate Reg. \$42.00 **30% off**
Heath Reg. \$45.00 **20% off**
Dee Reg. \$44.00 **30% off**
Leather Tie Reg. \$46.00 **20% off**

Beanie Reg. \$39.00 **40% off**
Pop Jr. Reg. \$35.00 **20% off**
Mary Lou Reg. \$31.00 **40% off**
Bench Reg. \$44.00 **20% off**

Eagle Reg. \$48.00 **30% off**
Bimini Reg. \$69.00 **20% off**
Beacon Reg. \$45.00 **30% off**
Algier Reg. \$56.00 **30% off**

Roscoe Reg. \$40.00 **50% off**
Yale Reg. \$49.00 **30% off**
Alumni Reg. \$48.00 **30% off**
Drake Reg. \$75.00 **20% off**

Del's Department Store Formerly Brader's
141 E. Main, Northville
Del's Shoes
153 E. Main, Northville

Del's Department Store
322 S. Main, Plymouth
HOURS: Mon. - Sat. 9 to 6
Thurs. & Fri. 9 to 9
Closed Sunday

Del's His & Hers Clothing
Great Oaks Mall, Rochester
Del's Shoes
Great Oaks Mall, Rochester

thompson glass company
"Since 1929"



One of the Midwest's largest suppliers of stained glass materials & accessories for the beginner to the advanced do-it-yourselfer.

We also specialize in **CUSTOM LEADED STAINED GLASS** for the home
Kitchen Cabinets
Bathroom Windows
Sidelights

10% OFF
with coupon only thru 11-15-82

Glue Chip Glass
50% OFF
Reg. \$4.00 Sale \$2.00
Minimum purchase 24 x 36 stock sheet
Limit 2 thru 10-31-82

Call us or better yet, come in and discuss your ideas with one of our stained glass experts.



43726 Grand River W. of Novi Rd. Novi 349-9393
Mon.-Thurs. 8:30-5
Fri. 8:30-7
Sat. 10-3

SPECIAL SALE
Oct. 21, 22, 23 Thurs., Fri., Sat.

CHRISTIAN Mother Goose Treasury
Reg. \$10.95 **\$9.95**

50% OFF Complete Bible
NIV Compact size, hard cover
Reg. \$9.95 **\$4.98**

Catholic Bible
New Testament, hard cover
\$2.00

All of these on sale while supplies last!

Exclusive Only In Our Store
Scripture Linens and Towels
Come see our wide selection of:

Bibles Pictures Plaques
Greeting Cards and many other gift items

Heaven & Earth, Inc.
41539 Ten Mile Rd., Novi
(at Meadowbrook, across from A & P)
348-3440
Leo & Sally Beauchamp

Annual Harden Sale
ON ALL UPHOLSTERED FURNITURE
Now until Nov. 15th

20% OFF

Important savings right now on selected hand-crafted traditional chairs. Hand-rubbed solid cherry arms and legs, hardwood frames, a host of beautiful upholstery fabrics.

Savings applies to all items in stock and special orders.

Also a select group of pictures at **50% OFF**

Gifts • Furniture • Antiques

the Early American Shop
621 South Main Plymouth 453-5320
Hours: 9:30-5:30 Mon.-Thurs.; Fri. 9:30-9; Sat. 9:30-5:30



McNiel Services
43601 Grand River, Novi
1 block W. of Novi Rd.
349-1551 348-9909

Open for Repairs Mon.-Sat. 8 a.m.-5 p.m.

We now have 3 grades of Gulf Gasoline
Regular Unleaded Diesel

SPECIAL OFFER
1/2 OFF Labor
ON ALL ELECTRONIC Tune-ups
Save as much as \$14.00

Expires 11-15-82

4 Tire Balance & Rotation Reg. \$20.00 Only \$15.00 with coupon, expires 11-15-82	Shock Sale \$14.95 Plus Installation Most U.S. Cars with coupon, expires 11-15-82
Cooling System Flush Includes 2 gal. Antifreeze, "T" & clamp, flush & labor \$28.95 with coupon, expires 11-15-82	Quick Oil Change Includes 5 qts. 10W/30 oil, filter, lubrication & 14 point car check \$12.95 with coupon, expires 11-15-82

WORLD OF WOOD HEAT



You'll look twice too when you see the **beautiful and efficient** **Carolina Stove**



50% OFF on the Patriot Stove

SAVE Hundreds of Dollars
\$ \$ \$ \$

Satisfaction Guaranteed

We Are Woodheat Specialists!!!

142 E. Walled Lake Dr. Walled Lake 669-3910

Fireplace Inserts
Free Standing
Furnace Add-ons
Pipe & Accessories

GRAND OPENING

"The Kitchen Store with a Whole Lot More"

Eliminate the guesswork, consult our Bridal Registry. Let us help you select the cooking utensils and dining accessories that will make the most of your new kitchen.

25% OFF
On Everything over \$5
(excluding Coffee, Tea, Cookbooks)

Special Items at 50% OFF

Complete line of Wilton Cake Decorating Supplies
Cake Molds Frosting Tips Decorating Books

Come in and Sample our Gourmet Coffee & Tea

Sale from Oct. 21-24, 1982 Thurs.-Sun.

Calphalon Cookware LaCreuset Cookware Chantal Cookware Trident Cutlery Imperial Cutlery Wilton Decorating Center Cookie Cutters Coffee Grinders Canister Sets Dish Towels Woks - Wok Tools Cook Books	Small Pasta Makers Robot Coupe Food Processors Gourmet Coffee Gourmet Tea Spices Melita Coffee Makers Chemex Coffee Makers Woodenware Cutting Boards Gadgets Galore Copper Cookware Mugs Galore Aprons, Mits, Hot Pads Hanging Racks
--	---

Cook's Connection
349-7981 43721 West Oaks - Novi West Oaks Shopping Center
Mon., Tues. Wed. 9-6
Thurs., Fri., Sat. 9-9
Sun. 12-5



McNish's

SPORTING GOODS & TROPHIES
"Where the Westside Athletes' Shop"

<p>Varsity Jackets Custom Fit Bowling Balls Custom Engraving</p> <p>SAUCONY Training Shoe Reg. \$35.00 Now \$19.99 Mens, Ladies • Limited Quantities</p> <p>INTERMEDIATE LEATHER Football & Tee Reg. \$12.99 SALE \$7.99</p> <p>Racquet Balls Reg. \$1.99 Now \$1 per can Seamco No. 558 or No. 559 or Wilson</p> <p>Select Group of Trophies & Placques 50% OFF Sale prices good thru 10-23-82</p> <p>Novi-Ten Shopping Center 10 Mile at Meadowbrook 348-1820</p>	<p>Team Outfitters ALL Summer Games 50% OFF</p> <p>Trac Ball Horseshoes Bocce Sets</p> <p>Badminton Volleyball</p> <p>ALL Golf Items & Accessories 25% OFF</p> <p>ADULT OR YOUTH Tube Socks 6 Pair \$5</p> <p>Mon.-Fri. 9-6 Sat. 9-5</p>
---	--

Brainer's Garden Land

GREENHOUSE & NURSERY

We are having a
Hanging Basket SALE!

No Limit Reg. \$7.99
\$3.99 8" Basket

Beautiful, Large Plants

Choose from:
Wandering Jew
Piggy Back
Bridal Veil
Spiders
Bolivian Jew
English Ivy
Grape Ivy
Philodendron

African Violets
Reg. \$2.99
\$1.49

Don't Miss this Sale

Prices good thru 11-1-82

51701 Grand River
Wixom (1 1/2 mile W. of Wixom Rd.)
349-9070
Mon.-Sat. 9 a.m.-5 p.m.

Dr. Fred Weiser

Optometrist

Invites you to take advantage of an inflation fighting savings on:

Offer good thru Oct. 28, 1982

FRAMES Men's, Women's, Children's We have a large selection for everyone Not to be used with any other offer	50% OFF
--	----------------

Contact Lenses Starting at **\$59**

All frames and lenses guaranteed for one year
All insurance and Medicaid accepted

209 S. Lafayette South Lyon 437-3351 519 N. Pontiac Trail Walled Lake 624-1707

Save \$4

on regular subscription price
OF YOUR AWARD-WINNING
COMMUNITY NEWSPAPER
Novi/Walled Lake News

SPECIAL OFFER—NOW THRU NOV. 30
52 weeks—for only \$8
(NEW SUBSCRIBERS ONLY)

Regular Subscription Price—\$12/yr.
Clip Our Order Form Below

Yes, I would like to subscribe to (check one)

South Lyon Herald Northville Record
 Milford Times Novi-Walled Lake News

and I am enclosing \$8 by check money order

NAME _____
ADDRESS _____
CITY _____ ZIP _____

MAIL TO:
SLIGER/LIVINGSTON COUNTY PUBLICATIONS
P.O. Box 899 Brighton, MI 48116

Novi Auto Sales

"Price Slicer"
Unbelievable Special
1974 Ford Pick-Up
Was \$895.00
NOW \$447.50
Price good thru 10-27-82

These Special Prices Only for 1 Week
(to 10-27-82)

<p>'78 Mustang Like new Was \$2795. Now \$2595</p>	<p>'79 Datsun 310 Air, stereo Was \$3495 Now \$3195</p>
<p>'78 Camaro T-tops, loaded Was \$4295 Now \$3995</p>	<p>'76 Comet 6 cyl. auto, gas saver Was \$1295 Now \$995</p>

26179 Novi Rd., Novi 349-7955
1 mile S. of 12-Oaks

O'SHEA'S TAVERN

49110 Grand River at Wixom Rd.
348-4404

Live Bands Dancing
Thurs., Fri., Sat.

NOW APPEARING
"High Country"

Thurs. Prime Rib Dinner	\$4.95
Fri. Fish & Chips "All You Can Eat"	\$3.95
Sat. Strip Steak 8 oz. (11:30 p.m.)	\$4.95

EVERYDAY Pitcher Special \$3.50 11 a.m.-Noon

Wed. Ladies Night 2 for 1 Drinks
(House Brands 9 p.m.-2 a.m.)
Also at Lunch Wed. 11 a.m.-Noon

Don't Miss Our Halloween Party Sat., Oct. 30
Prizes for Best Costume!

MR. TILE CO.

TWELVE OAKS MALL
348-8850

Come And See Michigan's Largest Selection Of Floor & Wall Coverings



UNDER THE WATER TOWER AT 12 OAKS

We Beat ALL Deals!

SALE! ARMSTRONG SUNDIAL™ SOLARIAN®
...an economical Solarian no-wax floor.
\$8.95 Sq. Yd.
From

- Economical and now sale-priced, too.
- Exclusive Mirabond® no-wax wear surface.
- Assorted patterns and colors.

(Armstrong So nice to come home to™)

Save the cost of installation!
We've got the Armstrong no-wax Solarian Tile floors you can install yourself.

FROM AS LITTLE AS **69¢** SQ. FT. All Others **23-50% OFF**

- Scuff-resistant Mirabond® surface keeps a sunny shine without waxing for longer than vinyl no-wax floors.
- Installation is easy. Just peel, place, and press. Each tile is self-adhering.
- Choose from dozens of dazzling colors and patterns — our Solarian Tile selection is the greatest!

Armstrong WE BEAT ALL DEALS

ALL **WALLPAPER**
Choose from 220 Books
30-40% OFF

Best Selection in Michigan
CERAMIC TILE
From **89¢** per sq. ft.
Others up to 70% Off

Colony **SALE**
MIX 'N' MATCH
HUNDREDS OF GREAT COLORS AT NO EXTRA COST
\$10.99 GAL.
OUR FINEST WALL PAINT
Scrub brush tough rich flat finish. Easy to use, dries in minutes and tools wash in water.

MR. TILE CO., NOVI Mon.-Fri. 9-8:30 Sat. 9-5:30 Closed Sunday

REDFORD 9300 Telegraph 255-1134 ROYAL OAK 1614 S. Woodward 542-2525 E. DETROIT 21011 Gratiot 778-8566

An amazing new way you can make color prints from negatives or slides quickly, easily, beautifully

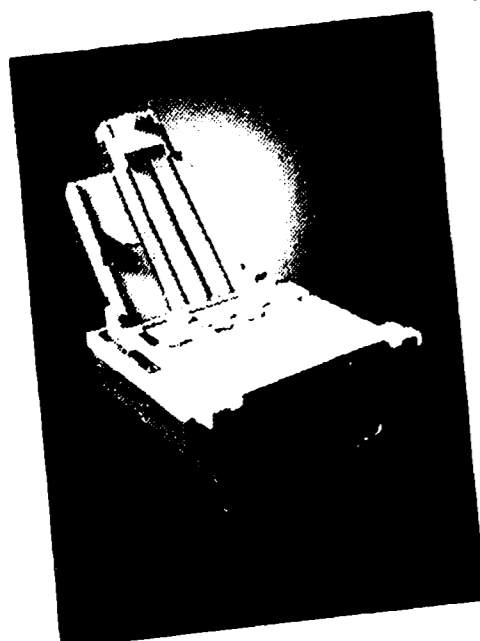

Ektaflex Print Maker

Chemicals and Paper

Now on Sale Special Offer

30% OFF

50% Off a Select Group of Ready-Made Picture Frames

Northville Camera and Hobby Shop

105 E. Main St. Northville, MI 349-0105



Save \$4

on regular subscription price OF YOUR AWARD-WINNING COMMUNITY NEWSPAPER

Northville Record

SPECIAL OFFER—NOW THRU NOV. 30

52 weeks—for only \$8

(NEW SUBSCRIBERS ONLY)

Regular Subscription Price—\$12/yr.

Clip Our Order Form Below

Yes, I would like to subscribe to

(check one)

- South Lyon Herald
- Northville Record
- Milford Times
- Novi-Walled Lake News

and I am enclosing \$8 by check money order

NAME _____

ADDRESS _____

CITY _____ ZIP _____

MAIL TO:
SLIGER/LIVINGSTON COUNTY PUBLICATIONS
P.O. Box 899 Brighton, MI 48116

Eight & Taft Auto Service

710 W. Eight Mile

349-5115

"Your Complete"



Auto Service Center

REPAIR HOURS

Daily 7:00-5:00 Minor Repair till 8:00 p.m., Sat. 7:00-5:00

- NIASE Certified Mechanics
- Domestic, Import & Diesel Service & Repairs
- Tires, Batt & ACC



(Repairs Only)



24 Hour Road Service

SALE BF Goodrich Tires

WE WILL MATCH OR BEAT ANY CURRENT ADVERTISED PRICE (Same Size and Type)

SIZE	OUR BEST STEEL BELTED RADIAL Life Saver XLM	STEEL BELTED RADIAL All Season
P155/80R13	47.20	41.80
P165/80R13	49.10	43.50
P165/80R13	52.20	48.70
P185/75R14	54.80	52.10
P195/75R14	59.60	56.10
P205/75R14	62.20	58.60
P215/75R14	63.30	60.80
P225/75R14	67.10	
P205/75R15	64.60	58.90
P215/75R15	67.10	61.40
P225/75R15	69.60	63.30
P235/75R15	74.60	67.90

Discount Tire Sale

Radial Quality Firsts - Summit Tires

SIZE	BETTER STEEL BELTED	PREMIUM STEEL BELTED	STEEL BELTED ALL SEASON
P155/80R13	37.27	41.80	39.85
P165/80R13	38.60	46.20	42.50
P185/80R13	43.40		46.35
P185/75R14	43.90	50.60	46.85
P195/75R14	46.20	53.75	49.32
P205/75R14	47.95	55.85	51.20
P215/75R14	48.85	56.75	52.50
P225/75R14		62.60	57.50
P205/75R15	50.20	58.40	53.75
P215/75R15	50.95	59.50	54.50
P225/75R15	55.90	63.45	59.80
P235/75R15	58.20	67.50	62.00

Disc Brake Special Front Reine Most Cars \$59.90	Interstate Battery Save \$10.00 On All Batteries Group 24 36 month warranty \$37.75
Oil Filters 1/2 OFF Most Sizes With Coupon \$2.65	Air Filters 1/2 OFF Most Sizes With Coupon \$2.95
Cooling System Flush Including 2 gal. Anti Freeze, Flushing T & Clamps, Labor \$29.43 Plus Tax	Snow Tire Mounting Special Mount Tires on Rims, Computer Balance \$15.95 With Coupon

Coupons Expire 11/30/82

GOLDEN OAKS CONVENIENCE STORE

PACKAGE LIQUOR DEALER

50% OFF While supplies last

Villa Brenta Lambrusco Wine **\$1.35** 750 ml.

WEEKLY WINE SPECIALS

MELODY FARMS HOMOGENIZED Milk **\$1.89** Gal.

EVERYDAY LOW PRICES MELODY FARMS 2% LOW-FAT Milk **\$1.79** Gal.

MELODY FARMS 1/2% LOW FAT Milk **\$1.69** Gal.

Budweiser Miller Lite Strohs Pabst **\$8.99** CASE

Plus tax & deposit 24-12 oz. cans

Faygo 1 Liter, **59¢** Plus deposit

Coke, Pepsi, 7-Up 8 Pack 1/2 Liter Bottles **\$2.59** Plus Deposit

24185 Haggerty corner 10 Mile Rd. Novi **OPEN 7 DAYS • 8 A.M.-11 P.M. 476-5690**

OPEN 24 HRS

LEMON CHOCOLATE HONEY DIPPED OLD FASHIONED PLAIN

DUNKIN' DONUTS

39415 WEST TEN MILE ROAD • NOVI (Corner of Haggerty) 477-3978

Purchase One Dozen at Regular Price Get **1/2 DOZEN DONUTS FREE** Offer Good Mon-Thurs Expires 11-1-82

DONUT LOVERS DOZEN 15 DONUTS for **\$1.99** Reg. \$3.55 (30 Donut Limes) Offer Good Fri-Sun

The Glass Pumpkin Jar with a dozen Sugar Cookies **\$4.49** Retail Value \$8.58

White Supplies Last! **Cider Available** Glass or Gallon

PRESENT THIS AD FOR SPECIAL PRICES

LUNCH SPECIAL - SOUP, BREAD & BUTTER DONUT & COFFEE \$1.49 Expires 11-1-82

LEMON HONEY DIPPED PLAIN POWDERED SUGAR RAISED JELLY BAVARIAN KREME

478-0444

Swendolyn's Ltd.
24193 Haggerty Rd. @ 10 Mile Novi, MI 48050

"We find the unusual a challenge, We'll find it or make it for you"

\$5.00 OFF Lapel Narrowing

50% OFF On Installation of your favorite Orange Zipper

25% OFF Your other favorite Zipper Colors

\$200 OFF Any Alteration (\$6.00 or more)

It's Pumpkin Time!

BRING IN THIS AD

HOURS
Mon.-Thurs. 9-8:30
Fri., Sat. 9-5
Special Hours by appointment

SOME OF OUR SERVICES FOR MEN & WOMEN INCLUDE:

- Zippers A Specialty!
- Uniforms & Career Apparel (By Order Only)
- Leather Clothing Repair
- Monogramming
- Knits Hemmed & Repaired
- Alterations And Repair
- Coats And Jackets Relined
- Restyling
- Reweaving
- Custom Clothing

"All-Season"
Premium Radial
\$37⁹⁰
 AR78x13 or 155/80 R13
 Free Road Hazard Guarantee

WHITEWALL	
P165/80R13	\$41.90
P185/75R14	\$49.95
P205/75R14	\$53.95
P215/75R14	\$56.95
P205/75R15	\$56.95
P215/75R15	\$58.95
P225/75R15	\$61.95
P235/75R15	\$64.95

Hi-speed Computer Wheel Balance
50% OFF

COMPLETE Disc Brakes \$55 ⁰⁰ Expires 10-20-82	Tune-up Includes parts most cars For 8 & 6 cyl. \$40 ⁰⁰ Expires 10-20-82	Tires Balanced and Rotated \$18 ⁰⁰ Expires 10-20-82
---	---	---

LOW PRICE AUTO REPAIR
Tech Auto Service
 21001 Pontiac Trail at 8 Mile Rd.
 437-0553

50% off Salt Delivery
 (free delivery for senior citizens)

50% off installation if any new water Softener
 Expires November 30, 1982
 Must present this ad for discounts
Soft Water Works

SALES • SALT • SERVICE MOST ALL MAKES
 RESIDENTIAL • COMMERCIAL
 featuring **Water-King**
 Water Conditioning
DURACUBE Conditioning Salt

Complete Line Of Filters
 Free Water Analysis
 We Honor
 Locally Owned By **437-7501** **Semca**
 Chris Williams 345 Lafayette S. Lyon
 For Service Calls After Hours 437-8461

ITASCA Quality Chain Saw Oil Sale

Engine Mix
 16:1 Oil Mix
\$3⁷⁵ 6 Pack

Bar & Chain Oil
 Reg. \$7.95 Sale **\$3⁹⁵** Gal.

Cash & Carry

New Hudson Power
 53535 Grand River at Haas
 437-1444

Winter's on the way

16 H.P. Tractor
 Case Snowblower
Save over \$1150

All Hydraulic drive & lift
All other tractors and implements on Sale at Big Savings
Many used Trade-in Tractors available

Case

Cash & Carry
NEW HUDSON POWER
 53535 Grand River at Haas
 Hours: Mon.-Fri. 9-6 Sat. 9-4
 2 miles West of Wixom Rd. **437-1444**

Extra Heavy Duty Homelite Generators

1/2 Price

- 4800 watts continuous duty
- 120/240 volts
- 1800 rpm slow speed
- Electric start
- 12 volt charging system
- 16 hp cast iron Kohler engine

Garden Weeders
 Reg \$19.95 **\$6⁹⁵**
 Sale

NEW HUDSON POWER
 53535 Grand River at Haas
437-1444

50% OFF **BOB-CAT**

HEAVY DUTY COMMERCIAL
 4 H.P.
21" Mower
 with rear bagger
 "2 in 1" Mulcher or Bagger
 Reg. \$380.00
Sale \$179⁹⁵

- 4 H.P. Cast Iron cylinder
- Stellite exhaust valve & seat
- Oil pressure pump
- Stay power
- mechanical governor
- C.D. ignition
- 2 Qt. gas tank
- All steel deck & handles
- Extra large steel wheels

Limited Quantities
 Cash & Carry

NEW HUDSON POWER
 53535 Grand River at Haas
New Hudson 437-1444

<p>Sale Price</p> <p>1/2" copper pipe \$3.60 10 Ft 3/4" copper pipe 5.70 Length 1 1/2" PVC pipe 3.20 2" PVC pipe 4.60 3" PVC pipe 8.75 4" PVC pipe 13.00</p> <p>Cedar Mailbox Posts \$18⁰⁰-25⁰⁰ value \$10⁰⁰ While supply lasts</p> <p>Mail Boxes in stock only 30% OFF 5 gallon Driveway Sealer \$13.10</p>	<p>50% OFF All Stock MIAMI CARY Medicine Cabinets DISCONTINUED CUPRINOL Stains</p> <p>Clearance Sale</p> <p>36"x36" One Piece Shower Unit Reg. 318.⁰⁰ 159⁰⁰ Harvest Gold</p> <p>5 1/2" Right Hand Harvest Gold Tub Reg. 292⁰⁰ 146⁰⁰</p> <p>33"x22" Double Stainless Steel Sink Reg. 62.⁵⁰ 31²⁵</p> <p>25"x22" Single Stainless Steel Sink Reg. 51.⁸⁵ 25⁸³ only while supplies last</p>	<p>Gerald Kerosene Heaters</p> <p>600BTU \$75.00 700BTU 95.00 9500BTU 185.95 18,000BTU 243.75</p> <p><i>Buy a heater and get 5 gallons of Kerosene free!</i></p> <p>Wiss Tin Snips</p> <p>V-13 \$9.60 \$4.80 A-12 10.05 5.00 A-11 11.10 5.55 A-10 14.40 7.20</p>
---	---	--

New Hudson Lumber
 New Hudson 56601 Grand River 437-1423



franny's

ONE-YEAR ANNIVERSARY SALE
(thru October 23)

- NYB CORDUROY BLAZER
SIZES 5/6—15/16. RUST, NAVY, GREY, CAMEL
REG. \$56⁰⁰ SALE \$42⁰⁰
- HOLIDAY DRESSES
50% OFF
- CORDUROY & WOOL PRAIRIE SKIRTS
30% OFF
- CO-ORDINATES
PURCHASE A JACKET (REGULAR PRICE),
BUY MATCHING SKIRT OR PANT
AT 50% OFF
(Sale limited to quantities in stock)

SALE HOURS:
MON.-SAT. 10-6, THURS. & FRI. 10-9



David's Headstart Salon

Ladies' Haircut \$10⁰⁰
With Blowdry & Curling Iron
~~\$14⁵⁰~~ - \$18⁵⁰

Men's Haircut \$9⁰⁰
With Blowdry \$11⁵⁰

Children 12 and under \$9⁰⁰
With Blowdry & Curling Iron
~~\$11⁵⁰~~ - \$15⁵⁰

Boys' \$8⁰⁰
With Blowdry \$10⁰⁰

Perms COMPLETE \$35⁰⁰
These prices for Pam, Cheira & Linda only

LeJoy Hair Spray
1/2 Off

David's Headstart Salon

125 W. Lake South Lyon 437-6886

Mon.-Wed. 9-5:30
Thurs., Fri. 9-8:00
Sat. 9-4:00



SUPER TRUCKLOAD

SALE • SALE • SALE • SALE

Coal Sale
50-65% OFF

Lump Coal ... **\$65**
Egg Coal ... **\$55**
Stoker Coal ... **\$65**
Cannel Coal ... **\$45**
AND RUN OF THE MINE

Load Your Own
Any quantity, bring own container. Load at your own risk, not responsible for accidents.
While supplies last.

Farmer's Petroleum Cooperative
Highland/Howell Branch
212 E. Livingston St., Highland
(313) 887-4109 (517) 548-2810
1 block E. of Milford Rd. on Livingston
Mon.-Fri. 8-5:30; Sat. 8-2

Morton Salt
Water Conditioning Products
Recommended by leading manufacturers of water softener appliances
1 Week Only!
(Now thru 10-27-82)

Rock Salt ... **\$3⁹⁹**
Reg. \$4.65 80 lb. bag

Salt Pellets ... **\$5⁴⁹**
Reg. \$5.99 80 lb. bag

Salt Pellets ... **\$6⁹⁹**
Reg. \$7.55 80 lb. bag
While supplies last

Farm Bureau
FARMERS' PETROLEUM

Last 4 Days

Dancer's Fashions

98th Anniversary Sale

NOW THRU OCT. 24th!

FOR HER...

Misses Blouses. Beautiful solids & prints Sizes 8-18 Reg. \$18 Sale 14.97

Misses Dress Slacks. Classic styles in fall shades Reg. \$35 Sale 24.97

Misses Dressy Blouses. Poly, crepes in assorted shades Reg. \$28 Sale 18.97

Junior Tops. Up-dated styles in sizes 5-13 Reg. to \$24 Sale 16.97

Junior Dress Slacks. Sensational styles in sizes 5-13 Reg. \$28 Sale 19.97

Junior Skirts. French canvas in trouser styles Reg. \$28 Sale 19.97

Junior Sweaters. Novelty styles from famous makers Reg. to \$28 Sale 19.97

Bonnie Daan® Knee Socks. Buy 3 & Save
knee highs Reg. to \$8 Sale 18.97

"Status" Jeans. Straight leg in junior & misses sizes Reg. \$26 Sale 18.97

FOR HIM...

Men's Sport Shirts. Assorted plaids in sizes S,M,L,XL Reg. \$13 Sale 9.97

Haggard® Slacks. Expand-O-Matic Magic Stretch slacks Sale 19.97

Men's Shelland Sweater. 100% wool in assorted shades Reg. \$25 Sale 18.97

FOR THE KIDS...

Girl's Stadium Jackets. Quilted shell in sizes 7-14 Reg. \$38 Sale 29.97

Girl's Corduroy Knickers. Assorted shades in sizes 7-14 Reg. \$12 Sale 7.97

Boys' Polo Shirts. Long sleeve, assort. in sizes 4-7 Reg. to \$10 Sale to \$6.97

Boys' Flannel Shirts. Assorted plaids in sizes 8-20 Reg. \$10 Sale 7.97

Boys' Sport Shirts. Assorted plaids in sizes 8-20 Reg. \$10 Sale 7.97

Select Group
Jewelry
1/2 off

Dancer's Fashions

120 E. Lake South Lyon 437-1740
Mon.-Sat. 9-6 Fri. till 8

435 N. Main Milford 685-9401
Mon.-Fri. 9-6

6th Anniversary Sale

Oct. 20-Oct. 27

50% OFF

Red Flannel Factory Sleepwear



10% OFF
All Other Merchandise

Bring along this ad for your free gift

It's A Small World

134 E. Lake South Lyon 437-9964

M-Th 9:30-5:30
Fri 9:30-8:00
Sat 9:30-5:00

All Tropical Fish

1/2 OFF
October 20th thru October 24th
(feeders excluded)

South Lyon Pet Shop

22884 Pontiac Trail
In King Plaza
437-9540

Open Mon-Fri. 10-7
Sat. 10-6
Sun. 1-4



3 x 5 Card Files

50% off

B & P 88 Series Pads

50% off

The Typewriter Shop

131 E. Lake (10 Mile Rd.)
South Lyon, MI 48178

437-5522 349-5200

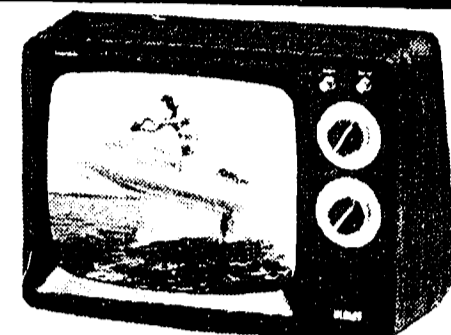

12" Diagonal Picture
Model AGR120W
\$79⁹⁵

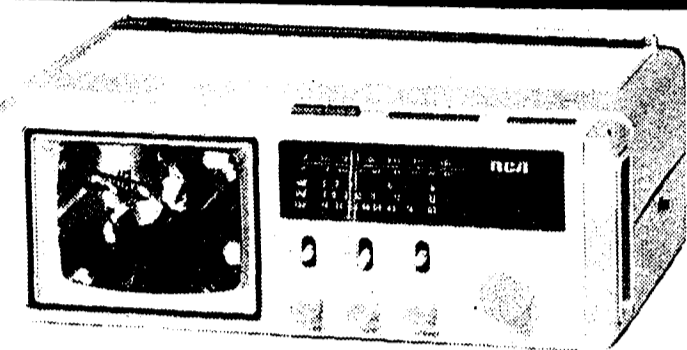

Playmate 5
5" duagibak AC/DC Black & White TV with AM/FM radio and Weather Band
Model AGR056 Reg \$199
50% off Sale \$99
Supplies limited



RCA SelectaVision Stereo VideoDisc Player
Buy one disc regular price, get second disc \$5.⁰⁰ off
Many new titles in stock
\$359⁹⁵

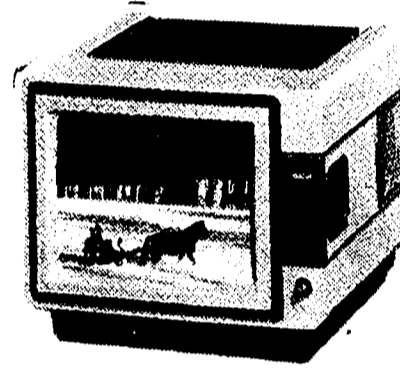

9" DIAGONAL

EGR291 This AC portable features SignalLock 18-position electronic tuning. Includes a drop-down handle and an earphone for private listening. 3 1/2" round speaker. Average power consumption of 46 watts. Silver finish on durable plastic cabinet. H-10" W-12" D-11 1/2". Available—Fall 1982.

\$249

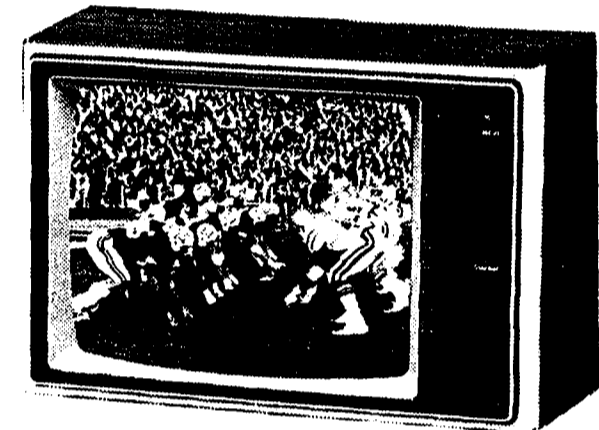

19" Diagonal Picture
Model FGR465
\$409



19" Diagonal Picture
Model FFR468R
\$459

For more details see:

C & F South Lyon Appliance

135 E. Lake

South Lyon

437-6303

99.9% RETURN ON INVESTMENT

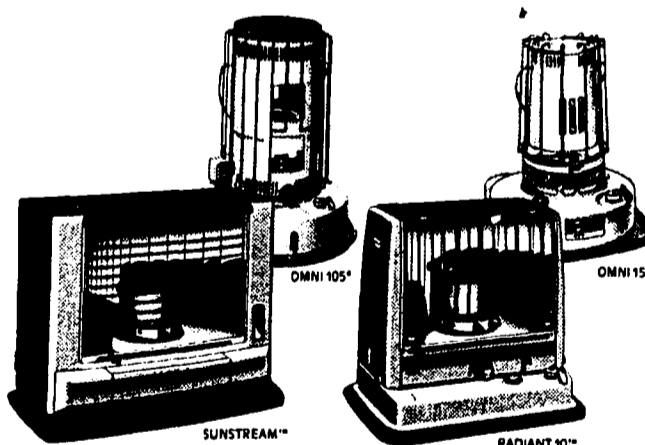

AT 99.9% FUEL EFFICIENCY, KERO-SUN PORTABLE HEATERS COST YOU JUST PENNIES PER HOUR TO OPERATE. Obviously, you don't like to see your heating dollars wasted. So get a heater that's virtually waste-free. A 99.9% fuel-efficient Kero-Sun portable heater. Nearly all the money you spend on fuel returns to you as heat. And it costs just pennies per hour to operate. There are Kero-Sun portable kerosene heaters for every kind of home and business. All are easy to operate. Smokeless and odorless in operation. Safety-tested and listed by Underwriters Laboratories. Get a 99.9% return on your heating investment. See all of our Kero-Sun portable heaters today. KERO-SUN HEATERS SAVE YOU MONEY WHILE THEY KEEP YOU WARM.



5 gals. Kerosene free with purchase of any heater
South Lyon Lumber & Farm Center
437-1751

South Lyon Lumber and Farm Center

415 E. Lake St.

South Lyon

437-1751

RECOMMENDED BY LEADING MANUFACTURERS OF WATER SOFTENER APPLIANCES

MORTON Pellets



COUPON Good for 1 free bag with the purchase of 5 bags any size



Latex Stain
For the rich, mellow look of stain... over paint.

Overcoat® Flat Finish
The strong-weather acrylic latex house paint.

Overcoat® Satin Finish
Now available in our 12 top Overcoat colors.

Primecoat®
For priming bare wood.

50% off all gallons of Olympic products in stock

LION AUTO SUPPLY

131 N. Lafayette

South Lyon 437-9752
AUTO PARTS STORES



Anniversary Sale

CARQUEST **Motor Oil**
10W40 Your Choice HD 30
89¢ Qt

Trade in your old cap and receive **\$1.00 Off** the purchase of a Carquest Cap

CARQUEST **Mufflers**
Fits most popular US trucks & cars
\$19⁹⁵

FREE ROTOR
with purchase of plugs & cap for electronic ignition or with purchase of points, cap & condenser for breaker ignition



Free Coffee & Door Prizes

HUFFY 6 1/2 GALLON **Gas Cans**
Only **\$10⁹⁸**

All Waxes and Polishes on Sale at Low Low Prices

Advance Antifreeze
\$3⁷⁹ Gallon

40 Month Battery \$42⁹⁵ Exchange Plus Tax

CARQUEST: the Right Place to buy auto parts. Right Parts • Right Price • Right Advice.

Crazy Horse Cutting Quarters

320 N. Lafayette (Next to Griswold Clinic)
South Lyon 437-1222



OPEN: Tues. - Sat. Walk-ins Welcome Evening by Apt.

* Family Discounts Sr. Citizens Students Kiddle Kutters

Hair Care Prices
Guys & Gals

Wash & Style \$8⁰⁰
Gals Cut & Style \$14⁰⁰
Guys Cut & Style \$10⁰⁰
Perms \$35-40
Complete package includes Cut & Style & Conditioner

50% off cut & style 1st Visit!

NEXUS

* The Finest In Professional Hair Care At Affordable Prices!



Fall is for planting

Shade Trees

Here's Why:

- Plant now and get a head start on spring and summer! Transplanting trees while they're dormant allows roots to grow this fall and results in more foliage produced in the spring.
- A well-landscaped yard can increase property value as much as 30% more than a house without green, growing plantings, according to recent studies.
- Real estate studies have shown that well-landscaped homes, especially those with beautiful trees, tend to sell faster and are more apt to be sold at the seller's asking price.

They're on sale now!
Wednesday thru Saturday only;
Sale ends Oct. 30th

SAVE!

25% OFF All Shade Trees
Deposit Required

50% OFF Bark Nuggets, medium
3 cu. ft. bag List \$7.39 Ours \$3.69



Growers of Quality Shade Trees
Designing • Planting • Construction
9710 Rushton Rd., South Lyon
Located between 7 & 8 Mile Rds.,
E of US 23, W. of Pontiac Trail

(313)349-1111 or 437-5454

Since 1941 Open Monday thru Saturday 8 a.m. - 5 p.m.



TAYLOR PRINTED HOT & COLD CUPS

8 oz. HOT CUPS	Reg. \$2.00	50 / \$1.00
10 oz. COLD CUPS	Reg. \$3.00	100 / \$1.50
16 oz. COLD CUPS	Reg. \$2.50	50 / \$1.25

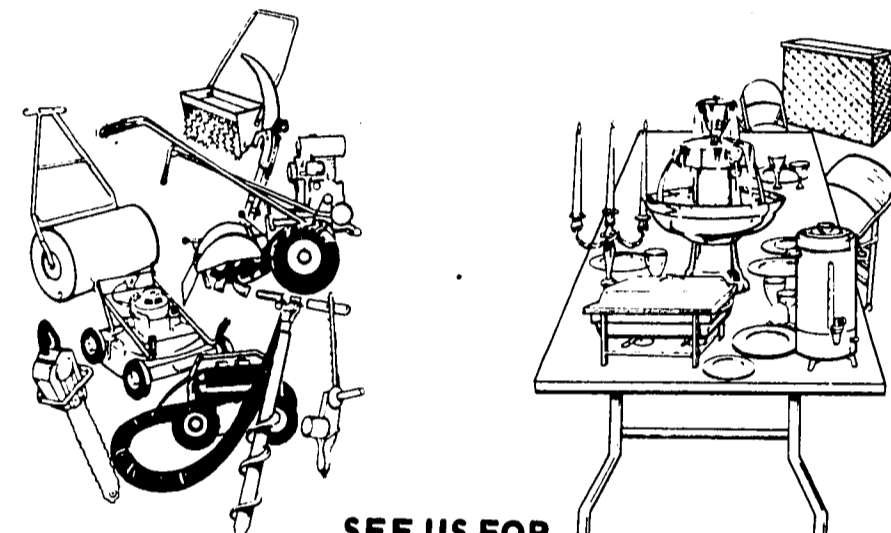

SEE US FOR PARTY SUPPLIES AND DISPOSABLES

BRIGHTON 7300 Grand River Ave. 227-2504
SOUTH LYON 475 Washington Street 437-2743

Save \$4

on regular subscription price OF YOUR AWARD-WINNING COMMUNITY NEWSPAPER

South Lyon Herald

SPECIAL OFFER—NOW THRU NOV. 30
52 weeks—for only \$8

(NEW SUBSCRIBERS ONLY)

Regular Subscription Price—\$12/yr.

Clip Our Order Form Below

Yes, I would like to subscribe to

(check one)

- South Lyon Herald Northville Record
 Milford Times Novi-Walled Lake News

and I am enclosing \$8 by check money order

NAME _____

ADDRESS _____

CITY _____ ZIP _____

MAIL TO:

SLIGER/LIVINGSTON COUNTY PUBLICATIONS
 P.O. Box 899 Brighton, MI 48116

116 N. Lafayette
 South Lyon

437-2838
 437-5650

SERRA INTERIORS

MAKE YOUR HOME BEAUTIFUL SALE

WALLHIDE®
 Latex Flat Wall Paint
NOW \$11.95 Gal.



SAVE \$300 Gal. with the exclusive Microflo Process®

- Stains, spots and normal household dirt clean up easily
- Excellent covering power in most colors
- Rich flat sheen
- Over 700 "new" colors to choose from
- Glides on smoothly and easily
- Thick, rich consistency
- Soap and water clean-up

Kirsch Drapery Hardware

20% OFF
 Our people can give you expert help with special windows



50% OFF
 Reg. Price
 In stock colors only

Window shades while you wait!



Why pay more and do your own work?

WALLPAPER SALE

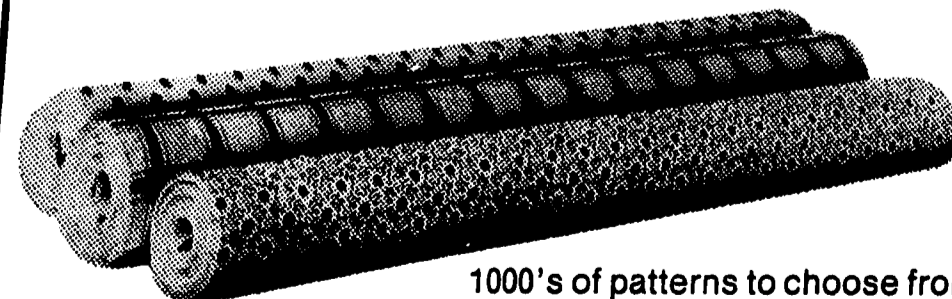

20% To 30% OFF

1000's of patterns to choose from

CARTER'S 50th ANNIVERSARY

Celebrate Big Values... Everyday!

GARAGE DOOR

• 4 Panel - 4 Sections.
 • Available in most popular sizes.

9'x7' \$129⁹⁹ 16'x7' \$319⁹⁵

CROSSBUCK STORM SCREEN DOOR

Your Choice
 1" X-Buck or 1" Self-Storing Doors

- Prehung
- White
- Hardware Included 3280 or 3680

\$5750

- 32"x80" or 36"x80"
- White Finish
- Hardware Included

FIBERGLAS FIBERGLAS SHINGLES

- 20 year limited product warranty
- Class A rated by underwriters laboratories.
- Self-sealing.

\$26 BUNDLE \$24⁷⁸ SQUARE

All-Purpose WOOD SIDING

7/16" x 4" x 8' **\$815**

ECONOMY STUDS

2" x 4" x 8' **.83¢**

WOOD FIBER INSULATION

CELLULOSE ATTIC INSULATION

\$3.79

- Covers 30 sq. ft. at an R-19 Value
- U.L. Listed
- Won't Scratch or Itch
- 30 lb. Bag

DO-IT-YOURSELF WITH OUR RENTAL MACHINE

RAILROAD TIES

7'-9'-8" **\$729**

HANDY PANELS

Fir Plywood... Ready To Finish!

2'x4'	2'x4'	4'x4'
1/4" \$219	\$635	
1/2" \$469	\$935	
3/4" \$649	\$1379	

ALUMINUM COMBINATION STORM & SCREEN WINDOWS

- Tile Triple Track.
- Qualifies for Energy Tax Credit.
- Mill Finish.
- Most Standard Sizes. (up to 48U1).

Many other sizes available **\$1895**

ALSO AVAILABLE IN WHITE AND BRONZE

OUTDOOR WOOD

2'x4'x8'	2'x4'x10'
\$218	\$225
2'x4'x12'	2'x4'x14'
\$328	\$385
2'x4'x16'	2'x4'x18'
\$436	\$455
2'x4'x12'	2'x4'x14'
\$546	\$626
2'x4'x16'	2'x4'x18'
\$717	

PLUMBING • ELECTRIC • HEATING NOW AT CARTER PLUMBING

LIGHT OXFORD KITCHEN

Classic Beauty in Solid Oak

50% OFF

SEVERAL OTHER STYLES AVAILABLE

Crystal Solar Furnace, Inc.

Solar heating energy at your fingertips

The State Of Michigan 1981 Credit is 20% Of The First \$2,000 Of The Systems Cost. This Unit Can Be Bought And Installed Yourself Or We Have Qualified Builders To Install It For You.

Solar Energy in Action

\$549⁹⁵

- Pre-assembled easy installation for the do-it-yourselfer
- Safe, non-polluting, clean heat
- Maintenance free exterior
- Five year warranty
- Most BTU's for your dollar

TOILET

• 12" Siphon-Jet
 • White

\$3850

LP gas avail. at comparable prices

GLASS-LINED WATER HEATERS

5 YEAR LIMITED WARRANTY

GAS MODELS	30 GAL. \$104 ⁹⁵	40 GAL. \$119 ⁹⁵
ELECTRIC MODELS	30 GAL. \$114 ⁹⁵	52 GAL. \$139 ⁹⁵

SEVERAL OTHER SIZES AVAILABLE

OAK VANITIES

- Solid oak.
- Doors available in raised or cane insert panels.
- Tops available.

24" x 21"	30" x 21"	36" x 21"
\$129 ⁹⁹	\$149 ⁹⁹	\$164 ⁹⁹

POLYETHYLENE PLASTIC PIPE

• 100 PSI
 • Meets NSF-ASTM specifications

1"	1 1/2"	2"
\$197 ⁹⁹	\$134 ⁶⁹	

*Full Cuts Only

*diamond crystal WATER SOFTENER SALT REGULAR GRADE

40 lb. BAG	80 lb. BAG
\$319	\$515

OPEN 7:30 TO 5:30 — 6 DAYS A WEEK — DELIVERY AVAILABLE

Webberville

1/4 Mile East of M-52 on M-13 (Grand River Ave.)

LUMBER 521-4180 PLUMBING 521-4777

Whitmore Lake

1/4 Mile East of US-23 on N. Territorial Rd.

LUMBER 665-5531 PLUMBING 665-5534

2 Locations to Serve You Better

RECT MILL OUTLET • DIRECT MILL OUTLET • DIRECT MILL OUTLET • DIR

CARPET REMS

Most **50% OFF**

Extra 10% with this ad

(Sale Ends Sat. Oct. 23, at 3:00 Sharp)

Fashion Flooring

340 N. Main St.
In The Heart Of Downtown Milford

RECT MILL OUTLET • DIRECT MILL OUTLET • DIRECT MILL OUTLET • DIR

HEIN SIGHT OPTICAL

"Top Quality at Reasonable Prices"

Frames • Tints 24 Hour Delivery
Most Insurance accepted (single vision)

COUPON

HEIN SIGHT OPTICAL

1/2 OFF Any Optical Option

with this coupon Lens Cleaner, Sports Band, Spec. Chains, Tints, etc.
(offer expires 12-1-82)

CLIP & USE

343 N. Main St., Milford
685-0128

AUTUMN SHOE SAVINGS

20% OFF ALL
Bass Casuals
Mens & Womens
4 Days Only!
Oct. 20, 21, 22, 23, 1982)



1/2 OFF
Summer Sandals
by Bass and Wimzees



1/2 OFF Select group of
Childrens Tennis Shoes Sizes 6-12

The London Shoe Shoppe

427 N. Main, Milford (next to The Moppet Shoppe)
684-2383

McMartin's Jewelry

at Commerce and Main St., Milford
684-8895

1/2 Off Sale



TORO

Snowblowers
On Sale Now!



Model: S200
Recall Start
\$329.95
REG. \$369.95

Ariens

EFFICIENT!

The two-stage snow removal action of an Ariens Sno-Thro is the fast, efficient way to throw snow out of your way! Ariens Sno-Thros are available ranging from 2.7 hp to 10 hp. Prices start at

All Models on Sale
Start **\$475.00**
At



SALE! SAWCHAIN

Save big on sharp new OREGON® cutting chain for chain saws. We're dealin' like never before on the world's leading sawchain. So take advantage of a great deal. Get a tough new OREGON® chain on your chain saw. Then get ready for some easy cutting.

OREGON October Special

- 12" CHAIN... Reg. \$26.90... **\$8.95**
- 14" CHAIN... Reg. \$21.90... **\$9.95**
- 16" CHAIN... Reg. \$23.90... **\$10.95**
- 20" CHAIN... Reg. \$25.90... **\$11.95**

SUPER CHISEL CHAIN... ALSO ON SALE!

HIGHLAND OUTDOOR CENTER
1135 S. MILFORD RD., HIGHLAND
(1 MILE S. OF M-59)
OPEN: Mon.-Fri. 9-6 (313) 887-3434
Saturday 9-2

ONE WEEK ONLY



STIHL

THE WORLD'S LARGEST SELLING CHAIN SAW

015L 14" Bar 2 cu. in. eng. FREE CASE 2000	028WB 18" Bar 2.9 cu. in. eng. FREE CASE 408	032 AV 20" Bar 3.1 cu. in. eng. FREE CASE 464	041 AV 20" Bar 3.7 cu. in. eng. FREE CASE 490
\$169	\$325	\$360	\$369

PRE-SEASON SALE

ALL MODELS ON SALE -
99.9% RETURN
ON INVESTMENT



KEROSENE

We sell kerosene and heater wicks for all brands

HIGHLAND OUTDOOR CENTER
1135 S. MILFORD RD., HIGHLAND
(1 MILE S. OF M-59)
OPEN: Mon.-Fri. 9-6 (313) 887-3434
Saturday 9-2

50% OFF Vertical Blinds



a difference you can see and feel.

50% OFF WOVEN WOODS



Selected Patterns All Others 40% Off

BONUS COUPON
EXTRA 10% OFF

- Bring this ad and receive additional 10% off any advertised offer in this ad. No exception.
- No credit cards.
- Must be paid for in full upon ordering.
- Does not apply to previous or awaiting orders.

50% OFF Mint Blinds



50% OFF

50% OFF Wood Blinds



50% OFF

COUPON WALLPAPER
SAVE 25%

- No previous orders
- No single rolls
- Reg. price
- Plus freight

Orchard Paint & Decorating Supplies

1095 S. Milford Rd., Highland (313) 887-6250

Try Our Easy Shop At Home Service™

Mon. - Fri. 8:30 - 6:00
Tues. & Thurs. 11:00 - 5:00



Main Street Market

Everyday Low Prices

 <p>C. F. Homogenized Milk \$1.68 Gallon</p>	<p>OLD MILWAUKEE Beer \$3.49 12 pk. 12 oz. Cans Plus Deposit</p>
--	---

<p>50% OFF SALE</p> <p>CONN CREEK Johannisberg Riesling Reg. 8.49 Sale 3.98</p> <p>MT EDEN Napa Gamay 7.39 3.59</p>	<p>DIET Like & 7-Up \$1.79 8 1/2 Ltr. Btls. Plus Deposit</p>
--	---

<p>WOODLEYS X Large Eggs Doz. 69¢ Mon.-Thurs. 9-9, Sun. 9:30-8, Fri. & Sat. 9-10 334 N. Main St., Milford, 684-1033</p>	<p>EVERYDAY LOW Jarlsberg Cheese \$2.99 LB.</p>
--	--

Save \$4

on regular subscription price
OF YOUR AWARD-WINNING
COMMUNITY NEWSPAPER
Milford Times

SPECIAL OFFER—NOW THRU NOV. 30
52 weeks—for only \$8
(NEW SUBSCRIBERS ONLY)
Regular Subscription Price—\$12/yr.
Clip Our Order Form Below

Yes, I would like to subscribe to
(check one)

South Lyon Herald Northville Record
 Milford Times Novi-Walled Lake News

and I am enclosing *8 by check money order

NAME _____
ADDRESS _____
CITY _____ ZIP _____

MAIL TO:
SLIGER/LIVINGSTON COUNTY PUBLICATIONS
P.O. Box 899 Brighton, MI 48116



Special 1/2 Off Offer

Now thru Oct. 23, 1982 Reg. \$15.50-\$23.00

Girls Sweaters Sale \$7.75-\$11.50
by Huk-a-Poo & Daddy's Favorite
Sizes 7-14

Infants & Children Apparel
Sizes Infant thru 14

THE Moppet Shoppe

417 N. Main St., Milford 685-9414

VISA MasterCard

The Ideal Gift A Family Portrait!

Gracon Studio Now Offering

1/2 OFF

The Sitting Fee*
Reg. \$15.00 to \$25.00

For Family Portraits

Call now for appointments
Portraits will be ready for Christmas
(Offer expires Sat., Nov. 6, 1982)

Gracon Studio INC.

1419 S. Milford Rd., Highland 886-8666
Located in the Colonial Village
*Sitting fee does not include finished portraits

Gold Depot ANNIVERSARY SALE

10% TO 50% OFF EVERYTHING

Bring this ad with you and receive an additional \$10.00 off
on any purchase of \$50.00 or more.

347 N. Main St. Downtown Milford 685-9770

Sale dates October 25 thru 30, 1982

LEVI'S® ACTION JEANS

New **Extra Stretch Performing Denim jeans**

Levi's for men
WITH A SKOSH MORE ROOM™

Buy One Pair at Reg. Price
Buy Second Pair **1/2 OFF**

(Offer expires Oct. 30, 1982)

Levi's MENSWEAR

QUALITY NEVER GOES OUT OF STYLE®

Arms Brothers
Store for Men Since 1837
361 N. Main St., Milford 684-4115

FREE PARKING IN REAR





UPHOLSTERY FABRIC SALE
50% off (In Stock)
20% off (Special Order)
 All for the Do-it-Yourselfers
 Foam Rubber Tool Kits
 All Supplies Available
 (Limited time)

Wallpaper
15-40% OFF

Upholstery & Decorating Shoppe
 844 E. Huron St., Milford
 685-2813
 2 Blk. East of Main St.

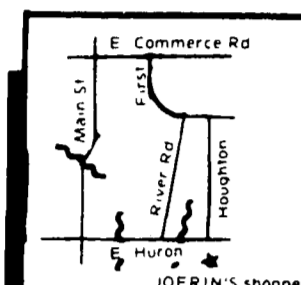
JOERIN'S
 Mon.-Sat. 9 to 5 Fri. 9 to 8

Anniversary Sale
 Collectibles & Gifts — We have gifts for all ages
Start your Christmas Shopping Now!
 Discounts from 10 to 50% off (Reg. price)
 (no coupon needed)
 Register for our free drawing (with this coupon)

Name _____
 Address _____
 Phone _____

1st - \$50 gift certificate
 3rd - \$15 gift certificate
 2nd - \$25 gift certificate
 You must be 18 years old to register
 (not redeemable for cash or sale items)

Barker's Gifts & Imports
 112 E. Lake St. South Lyon 437-1567
 Drawing & Sale end Dec. 6, 1982 8 p.m.

SAVE \$4
 ON REGULAR SUBSCRIPTION PRICE

Of Your Award-Winning
 Community Newspapers in
 Livingston County
The Brighton Argus
 OR
Livingston County Press

SPECIAL OFFER—NOW THRU NOV. 30
52 Weeks for only \$8
 NEW SUBSCRIBERS ONLY
 Regular Subscription Price — \$12/yr.
 Clip Out Order Form Below

Yes, I would like to subscribe to
 Livingston County Press Brighton Argus
 AND I AM ENCLOSING \$8.00
 BY CHECK BY MONEY ORDER

NAME _____
 ADDRESS _____
 CITY _____ ZIP _____

MAIL TO:
 LIVINGSTON COUNTY PUBLICATIONS
 P.O. Box 899 Brighton, MI 48116

SNOW FENCE
 For All Applications

50' Roll **\$21⁹⁵**

FENCE MART CO. INC
 7288 E. Grand River — Brighton
 227-3580

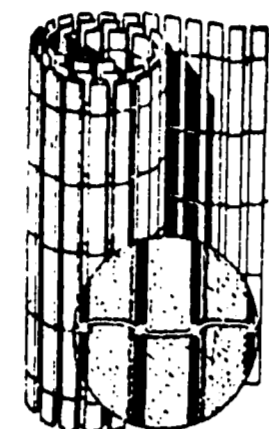

WOOD STOVE SPECIALISTS
 (Not Just a Sideline)

Specials on
"ONE-OF-A-KIND"
 Units

50% OFF
ALL CAST IRON COOKWEAR
 Offer Ends 10-30-82

Certified Installers
Accessories
Maintenance Supplies
Pipe & Fittings

HOT SPOT
WOOD/COAL BURNERS
 7288 E. Grand River
 2 Miles West of Brighton Mall
227-7072

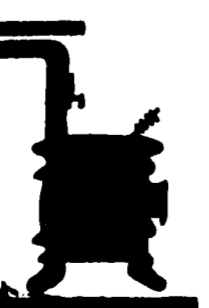

MT. BRIGHTON CHAIRLIFT SKI SHOP

50% OFF
ON ALL
Cevas Jackets & Pants

Many More Unadvertised Discounts
 on Roffe, Mother Karen, and More

Visa & Mastercard accepted. Gift Certificates Available.
 Certified, licensed technicians always on duty.
 OPENING OCTOBER 16 — NOON 'til 6 — 7 DAYS A WEEK **227-1124**

WATCH FOR YOUR LOCAL NEWSPAPER'S LEARN-TO-SKI PROGRAMS COMING IN JANUARY.

Mt. Brighton 1982-83 Calendar of Events!

NOV. ??—Opening day for ski season
 NOV. 6—Hiring day for Seasonal workers 9 A.M.-3 P.M.
 NOV. 27—Midnight Saturday Skiing begins.
 DEC. 17—Police Athletic League Benefit Weekend
 JAN. 8 & 9—Newport "Alive With Pleasure" Weekend
 FEB. 13—6th Annual Bikini Belles & Beaus Competition
 FEB. 27—Mardi Gras—Snow Sculpture & Costume Contests
 MAR. 13—Second Annual Slush Cup (Conditions Permitting)

Call or write Mt. Brighton for additional information on any of the listed events.
 Mt. Brighton Ski Area 4141 Bauer Road Brighton, MI 48116 (313) 229-9581 (313) 229-9582

OPENING DAY CONTEST
 I predict Mt. Brighton will open their 22nd season on _____ 1982.
 NAME: _____
 ADDRESS: _____ PHONE: _____
 CITY: _____ STATE: _____ ZIP: _____
 I got my copy of this newspaper at: _____
 The first 10 correct entries will each receive 2 free lift tickets. All entries must be received at Mt. Brighton by November 1, 1982. Mail entry to: Mt. Brighton, 4141 Bauer Road, Brighton, MI 48116. Winners will be notified by mail.

COUPON
FREE Delivery
 1 to 12 Yard Loads in local area thru Oct., 1982

4'x8'x15" to 20" Soft Load
Firewood \$49.00
 Birch & Fruitwoods \$59.00

More Economical than Firewood

Brookfield Bituminous 8^c lb. \$80 Cu. Yd.
Cannel Coal 7^c lb. \$75 Cu. Yd.
Anthracite \$750 50 lb. Bag \$150 Cu. Yd.

Stop "Lawn Jobs" with a "Rock of Nobles"
 Protect your property - order now before the roads get icy!
 Below are a few of the sizes & prices at the 1 ton rate Avg. Size.

Sports Car Specials 75-125 lbs. \$3.75
4 W.D. Truck Specials 125-275 lbs. \$7.50
Semi Stoppers 275-425 lbs. \$13.00

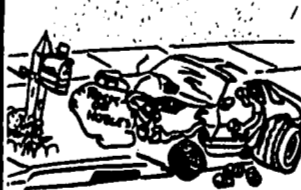

Truck Load Deliveries
 Top Soil - Pea Stone - Sand - Gravels
 1 to 12 Yard Loads

NOBLES 8 Mile Supply
 29450 W. 8 Mile at Middlebelt 474-4922 HOURS: MON.-SAT. 8-7 SUNDAY 10-4



GO FOR THE CASE DIFFERENCE.
 You'll be glad you did.

FOAM PADDED SEAT
 HYDRAULIC ATTACHMENT CONTROL
 SINGLE LEVER CONTROL
 RUBBER ISOLATION ENGINE MOUNTS
 HEAVY CAST IRON TRANSAXLE
 GEAR & SECTOR STEERING
 DRAG LINK AND TIE ROD BALL JOINTS
 MEAT TREATED SPINDLES
 FUEL TANK UNDER THE SEAT
 OPEN THRESHOLD

PRICE INCLUDES MOWER

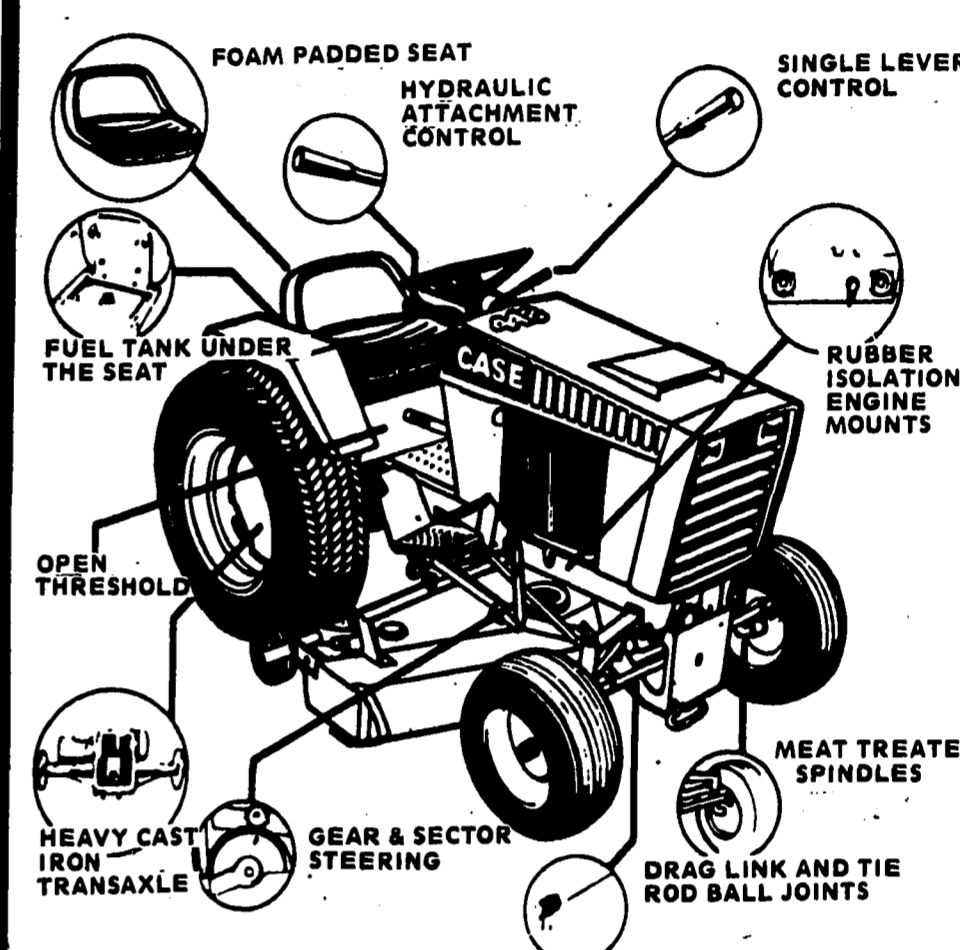

MODEL-HP	REG. PRICE	SAVE	SALE PRICE	UP TO 35% OFF REG. PRICE
110-10hp	2050.00	455.00	1595.00	
220-10hp	3235.00	885.00	2350.00	
222-12hp	3530.00	980.00	2550.00	
224-14hp	3975.00	1095.00	2880.00	X Power lift
444-14hp	4235.00	1145.00	3090.00	X Power Lift
446-16hp	4625.00	1275.00	3350.00	XX Power lift two cylinder
448-18hp	4985.00	1390.00	3595.00	XX Power lift Two cylinder.

Case FALL CLEAN-UP SALE

WESTERN AUTO

Drive a little. Save a lot
 Downtown Williamston
 115 W. Gd. River **655-1788**





For 25¢*

You're getting a great bargain with the Milford Times, Northville Record, Novi/Walled Lake News Or The South Lyon Herald



Where else can you get **Local Want Ads**

You can find your neighbors selling everything from cookie sheets to Cadillacs in the Green Sheet want ads. A bargain hunters delight with thousands of items offered for sale.

Where else can you get **High School Sporting Events**

Sports programs are the most visible activities of the area high schools. The hard work of area athletes is rewarded in part by the recognition we can give them. Our sports editors compile the information, and our photographers capture the action.

Where else do you get **Local News**

A weekly paper cannot begin to offer you news of national scope, but we will report news-worthy events in the immediate area.

Where else do you get **Government News**

Every week we send our reporters to all parts of the county covering City Councils, Township Boards, and County Commissioner meetings. You'll know what is happening to your tax dollars.

Where else do you get **Local Merchants Specials**

Smart retailers use special prices to attract new customers into the store. Every week, you'll find some of the best buys in groceries, hardware, furniture, clothing, tires, lumber and much more.

Where else do you hear of **Community Activities**

The heart of any community paper is its ability to reflect what is happening in the area. Local service clubs and organizations are constantly at work to improve the community. And we try to help them deliver their message.



All This **Package** Expertly for your enjoyment and then delivered to your door by young business people, our carriers... **EVERY WEDNESDAY**

*Our regular newsstand price

You can enjoy our newspaper for even less

52 Issues

ONLY \$8 Reg. \$12.00

OFFER GOOD THRU NOV. 30, 1982

Yes, I'd like to subscribe to:

Write in Newspaper At The Special Low Price of \$8 for A Full Year Subscription My Check is Enclosed

Name _____
Address _____
City _____ Zip _____

MAIL TO: LIVINGSTON COUNTY PUBLICATIONS, CIRCULATION DEPT.
1125 GRAND BLVD., SUITE 200, WARREN, MI 48090



WELCOME TO **ANDY'S FRUIT MARKET**

42409 GRAND RIVER, NOVI
EAST OF NOVI ROAD-348-2386
Prices effective thru Oct. 30, 1982

HOURS:
Mon.-Sat. 9-7 p.m.
Sun. 10-6 p.m.

HOMO Milk **\$1.69**
SAVE 30¢ Gal.

TREE RUN McIntosh Apples **\$4.99**
Bushel

Also available at popular prices
Jonathan Apples
Red & Golden Delicious
Cortland
Spys

FRESH FROM THE MILL NO PRESERVATIVES
Apple Cider
ONLY **\$1.49** Gallon
SAVE \$1.00 (Limit 2)

U.S. No. 1 MICHIGAN Potatoes
10 Lb. Bag **69¢**

HALLOWEEN Pumpkins
over 1,000 to choose from
All Sizes

Fall Squash **19¢** Lb.
Acorn
Butternut
Buttercup
Spaghetti

478-3703
478-3704

24195 Haggerty
at Ten Mile
Novi

Men's
Women's
Children's
Laurie's HAIR CONCEPTS
"Complete Hair Care"

HOURS
Mon., Tues., Fri. 9-5
W., Th. 9-8
Sat. 9-3

Haircut, Shampoo & Blow Dry

50% OFF **\$6**
Reg. \$12.00 Now
(For new customers only)
Valid any day with this coupon Expires 11-24-82

Young People's Special

\$2 OFF Haircut
Includes Shampoo & Blow Dry
With this coupon Expires 11-24-82

Ear Piercing

Reg. \$10.00 Now **\$8** **\$2 OFF**
With this coupon Expires 11-24-82

Manicures

Reg. \$6.00 Now **\$5** **\$1 OFF**
With this coupon Expires 11-24-82

Custom Perm

Reg. \$30.00 Now **\$25** **\$5 OFF**
Includes: Conditioner and either blow dry or set
Valid any day with appointment
With this coupon Expires 11-24-82

Highlites

\$5 OFF
Valid any day with appointment
With this coupon Expires 11-24-82

Just In Time...

GOOD TIME PARTY STORE

Inglenook

Chablis, Vin Rose, Burgundy
3 Liter Bottle Reg. \$7.99
Sale **\$5.89**

Martini & Rossi Vermouth **\$3.49**
Sweet or Dry Reg. \$4.99 Ea.

Martini & Rossi Asti Spumante **\$8.99**
Reg. \$11.99 Sale

7-UP, Like, Orange Crush, Diet 7-UP **99¢**
2 Liter Bottle Ea. Plus deposit

Budweiser Lite **\$8.29**
24 pac cans Plus Deposit & Tax

Labatts Blue Case **\$8.99**
Plus Tax & Deposit

All Carlo Rossi's **\$4.44**
3 Liter Reg. \$6.59

We still have Pepsi, and we'll gladly take your Pepsi returnables
Sale prices good through October 27, 1982

GOOD TIME PARTY STORE

567 SEVEN MILE ROAD
NORTHVILLE, MICHIGAN
349-1477

FREE DO-IT-YOURSELF

REAL BRICK

Another Quality Product of Michigan Brick, Inc.

DEMONSTRATION

Sun., Oct. 17 10 a.m.-2 p.m.

It's A Natural...



REAL BRICK
Another Quality Product of Michigan Brick, Inc.

Manufacturer's Representative will be here for the demonstration

Not an imitation... Genuine 1/2" kiln fired clay brick. More value for your dollar. Easy step by step application. Versatile interior/exterior use. Maintenance free, non-combustible. 10 color blends to choose from.

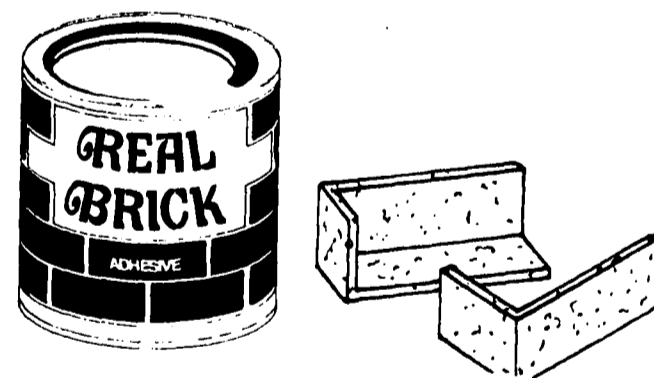

1¢ Sale 89¢

2 Keys for the price of 1 plus a penny
You can always use a spare!

Northville Lumber Co

615 E. Baseline Rd., Northville
349-0220

HOURS: M.-F. 8-7; Sat., 8-5; Sun. 10-2



TORO

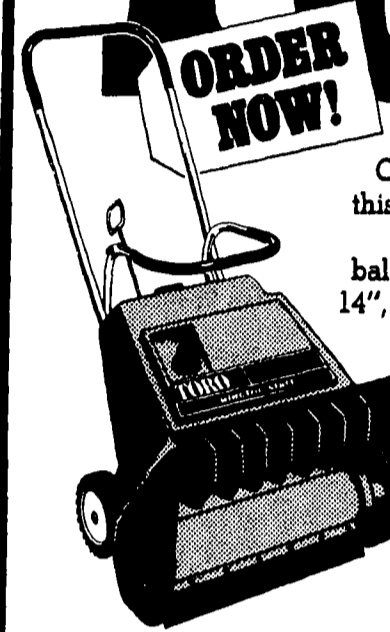

Hold Your Own For '80

Our allotted Toro® snowthrowers were gone early this winter, despite record production. But '80 dawn now reserves the model that's right for you. Pay balance by 12/1/82. Choose the all electric 12", gas 14", 20" or 20" Electric Start and save up to \$50 off '82 prices. Don't settle for less, winter will return.

Haven't you done without a Toro long enough?.. **TORO**

\$329⁰⁰ 20" Pull
\$379⁰⁰ 20" Electric

*Comparing dealer's regular price and promotional selling price.

Layaway Sale

Mark's Small Engine

Sales and Service
16959 Northville Road
Northville
349-3860

Better In The Clutch.

If you want a lawn tractor that doesn't lunge or leap into action, better get one from Toro.

Because then you'll get the only one with an automotive-type, pressure-plate clutch. For smooth shifting that idler pulleys can't give you.

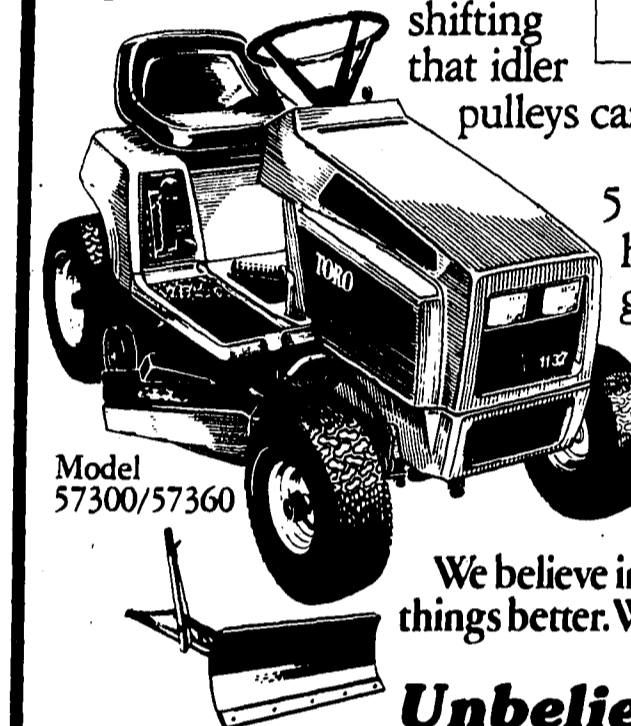
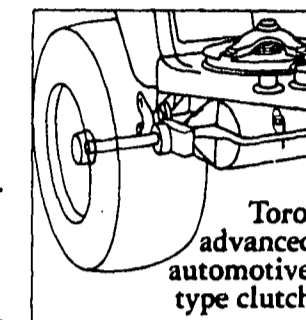

Couple this with 5 speeds and 8 or 11 horses, and you've got more lawn tractor than anyone else can give you. You've got a Toro.

We believe in making things better. We believe you do, too.

Unbelievable Price!

8 Hp. 32" Mower **\$1350⁰⁰** While quantities last

And we'll give you the snow blade

FREE!! (*\$2150* Value)

A Sale Everyone Understands...

1/2 OFF

Every Piece of Fine Furniture at Tenpenny's

Over stocked - Must move floor samples
Offer limited to in stock furniture (no special orders)
Offer good only on furniture purchased days of sale
Cannot apply to prior sales

4 Days Only

Thurs., Fri., Sat. & Sun.
Oct. 21-24

Sofas • Chairs • Lamps • Tables • Bedding • Lots More
Many famous names • All top quality furniture

TENPENNY
DISCOUNT FURNITURE

42951 W. 7 Mile
(in Highland Lakes Shopping Center)
2 miles W. of I-275
Northville • 348-7174

7 Years of Service

Family Portraits
Express what it means to be together

1/2 OFF
11" x 14" Portrait
With any additional purchase

(Camera charge not included)
Offer good thru Thanksgiving

Albright Photography
348-2248 • Northville

SALE LEISTCO SPORTS OUTLET
DOWNTOWN HOWELL

HOURS: MON.-FRI. 10-6, SAT. 9-5

50% OFF All Golf Bags
CONVERSE SALE

American Made Reg. List

Pro Stars HI-TOP \$55⁹⁵ \$72⁰⁰

All Star Leather HI-TOP \$39⁹⁵ \$56⁰⁰

All Star Leather LO-TOP \$36⁹⁵ \$50⁰⁰

Sweat Clothes— Top Quality American Made
8 Colors—Lettering On The Spot

Bowling Shoes & Bags 15% OFF

We now have Leotards & Leg Warmers
Exercise Mats— \$15⁰⁰

Complete Archery Supplies
— Arrows Cut To Length —

Varsity Jackets Quilted \$90/ w lettering
Any School Nylon Lined \$85/ w lettering

THE FURNITURE STORE

2-FOR-1 BEDDING SALE!!!

BUY THE FOUNDATION AND GET THE **MATTRESS FREE!!!**

TWIN SIZE **\$89** BOTH PIECES!!!

FULL SIZE SET \$109 QUEEN SIZE SET \$149

STORE HOURS
MON., WED., FRI. 10 to 8 — TUE., THUR., SAT. 10 to 6

THE FURNITURE STORE
9810 E. GRAND RIVER, BRIGHTON
1/2 MILE WEST OF US-23
227-5466

Waldenwoods Home Style CHICKEN DINNERS

\$6.95

SECOND HELPINGS ARE ON US!

COCKTAILS 50% OFF THIS WEEK!

ENJOY HOME COOKED DINNERS SERVED FAMILY STYLE IN A BEAUTIFUL WOODED SETTING OVERLOOKING LAKE WALDEN.

FAMILY OWNED AND OPERATED FOR OVER FIFTY YEARS

HOURS
FRI. SAT. 5 - 10 PM
SUNDAY 12 - 5 PM
COCKTAILS ARE AVAILABLE (313) 632-7304

WALDENWOODS HARTLAND
LANSING PONTIAC
ANN ARBOR DETROIT

Show this ad and get \$1.00 off each meal in your group

SAVE \$4

ON REGULAR SUBSCRIPTION PRICE

Of Your Award-Winning Community Newspapers in Livingston County

The Brighton Argus
OR
Livingston County Press

SPECIAL OFFER—NOW THRU NOV. 30

52 Weeks for only \$8

NEW SUBSCRIBERS ONLY
Regular Subscription Price — \$12/yr.
Clip Out Order Form Below

Yes, I would like to subscribe to

Livingston County Press Brighton Argus
AND I AM ENCLOSING \$8.00 BY CHECK BY MONEY ORDER

NAME _____
ADDRESS _____
CITY _____ ZIP _____

MAIL TO:
LIVINGSTON COUNTY PUBLICATIONS
P.O. Box 899 Brighton, MI 48116

WINTER DEFENSE SYSTEMS

KEROSUN
WE BRING COMFORT TO INNER SPACE

THE NEW MONITOR™ HEATING SYSTEMS—KERO-SUN'S CONVENIENT SOLUTION TO THE HIGH COST OF HEATING LARGE AREAS.

All through the heating season there are two systems to save you money while you stay warm and comfortable. Kero-Sun™ Monitor™ vented kerosene heating systems can heat an entire home or help your central heating system while you dial down the thermostat for big savings. Monitor™ heating systems deliver 18,000 BTU's or 30,000 BTU's of pure heat (depending on model) with remarkable fuel efficiency. In fact, they're two of the most fuel-efficient heating systems in the world. Automatically regulating heat output to give you even, constant warmth. Convenient? Monitor™ systems can be connected to large outside fuel tanks, eliminating the need for daily fueling.

The Monitor™ heating systems provide enough heat to warm a big family room. An entire home addition. A home workshop or basement recreation room.

Compact. Easy to install. Virtually maintenance-free. Safety-tested and listed by Underwriters Laboratories.

Monitor™ vented heating systems. Enjoy the economy of kerosene heating and the convenience of central heating. Install a savings system today.

MONITOR™ HEATING SYSTEMS SAVE YOU MONEY WHILE THEY KEEP YOU WARM.

\$100 OFF
THRU OCT. 31
On These Monitor Systems

MONITOR 30™
MONITOR 20™

99.9% RETURN ON INVESTMENT

KEROSUN
WE BRING COMFORT TO INNER SPACE

SALE PRICED

50% OFF
the First 5 gallons Fuel with heater purchase

AT 99.9% FUEL EFFICIENCY, KERO-SUN™ PORTABLE HEATERS COST YOU JUST PENNIES PER HOUR TO OPERATE.

Obviously you don't like to see your heating dollars wasted. So get a heater that's virtually waste-free—a 99.9% fuel-efficient Kero-Sun™ portable heater. Nearly all the money you spend on fuel returns to you as heat. And it costs just pennies per hour to operate.

There are Kero-Sun portable kerosene heaters for every kind of home and business. All are easy to operate. Smokeless and odorless in operation. Safety-tested and listed by Underwriters Laboratories. Get a 99.9% return on your heating investment. See all of our Kero-Sun portable heaters today.

KERO-SUN™ HEATERS SAVE YOU MONEY WHILE THEY KEEP YOU WARM.

Pricing May Vary by Dealer

SUNSTREAM™
OMNI 10™
OMNI 15™
RADIANT 10™

FOOTE GRAVELY TRACTOR
46401 Grand River - Novi
(West of Taft)

Mon. - Fri. 9-5
Sat. 9-1

348-3444

HIGHLAND OUTDOOR CENTER
1135 S. Milford Rd. - Highland
(1 Mile S. of M-59)

Mon. - Fri. 9-6
Sat. 9-2

887-3434



50% OFF cash & carry

HARVEST OAK and HARVEST CATHEDRAL KITCHEN CABINETS STYLE ONLY
It will never be easier than now to improve your home with beautiful, new kitchen cabinets

KITCHEN CABINETS
The "Custom-Look" from Merillat without the custom price tag.



HURRY! SAVE 50% OFF Harvest Cathedral/Harvest Oak
...cabinetry with beautiful, delicately sculptured, raised panels and frames of solid oak.
Offer ends November 13, 1982

- Since 1971 we have placed kitchens in over 15,000 homes.
- Custom cabinets including the latest in European styling.
- Appliances, built-ins, by Magic Chef, Thermador and Jenn Air.
- Design service available for homes, commercial and professional offices.
- Several Kitchens & Vanities Display
- VISIT OUR NEW SHOWROOM DISPLAY AND SAVE!
- We have over 8,000 Merillat Cabinets in stock—with 6 different styles to choose from

Ask About Our Lay Away Plan
K_s KITCHEN SUPPLIERS INC.
Use Your Visa or Master Charge

9325 MALTBY ROAD BRIGHTON 229-9554
OPEN: Mon. thru Fri. 8:00-5:00
Saturday 9:00 to 3:00 p.m.
THURSDAY NIGHT til 8:00 p.m.

BRANCH SHOWROOM 7012 DIXIE HWY. CLARKSTON 313-625-4440
Hours Daily 9 a.m. to 5 p.m.
Saturday 9:00 to 3:00 p.m.
THURSDAY NIGHT til 8:00 p.m.

Wilson Marine proudly announces the arrival of the Bayliner Boat Line!



See the Capri 1600
A Deluxe, Fully-Equipped 16-Footer complete with 85 HP Outboard & Trailer
FOR ONLY \$5995

This 16-footer is an all-new design. The engine is performance engineered, manufactured to Bayliner's exact specifications and perfectly mated to the boat. Likewise, the trailer is designed just for the boat and offers full hull support plus the easiest loading-unloading we've ever seen.

The affordability of this package should not lead you to think it is less than deluxe. Like our top-selling 1950 Capri, which has just been named BOAT OF THE YEAR by Powerboat magazine, this new 16 is loaded with equipment. And, it has been developed with the same degree of care that won our 19-footer Power-ship's top award for construction, styling, workmanship, handling, fuel economy and—most importantly—price.



Sport Boats- Fishing Boats & Cruisers
16 to 27 foot crafts

WHILE YOU'RE LOOKING AT OUR NEW BAYLINER LINE
Take Advantage of our
ACCESSORY SALE
ENTIRE WATER SKI DEPT.—MARKED 30% OFF
ADULT SIZE LIFE PRESERVER (Was \$8.10) SALE \$4.05
1-PERSON INFLATABLE BOAT (Was \$14.95) SALE \$7.49



6095 W. Grand River, Brighton
(At Lake Chemung)
LIVINGSTON COUNTY'S
ON-THE-WATER DEALER SINCE 1949
(517) 546-3774
Open 9 to 6 Mon-Sat — Sundays 9 to 1
See Us For BASS BOATS • SKI RIGS • DECK BOATS
FISHING BOATS • DECK BOATS • PONTOON BOATS
INBOARD-OUTBOARDS • SKIS

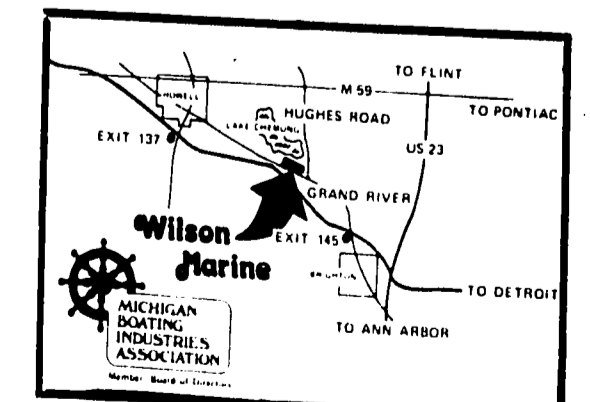

FALL SAVINGS Sale

Kraft Faced INSULATION \$13.99
3 1/2" x 15" Roll R-11

10% OFF All Wolmanized Lumber
20% OFF All Charmglow & Weber Bar-B-Ques

Damaged Doors & Factory Seconds From **\$1.99** Each
Landscape Bark Chips \$4.00 3 Cu. Ft. Bags
Fireplace Tools & Accessories 20% OFF

We're Overstocked

Save 50% On All In Stock Stair Components & Spindles

Save 10% On Any Special Order Stair Component

50% OFF

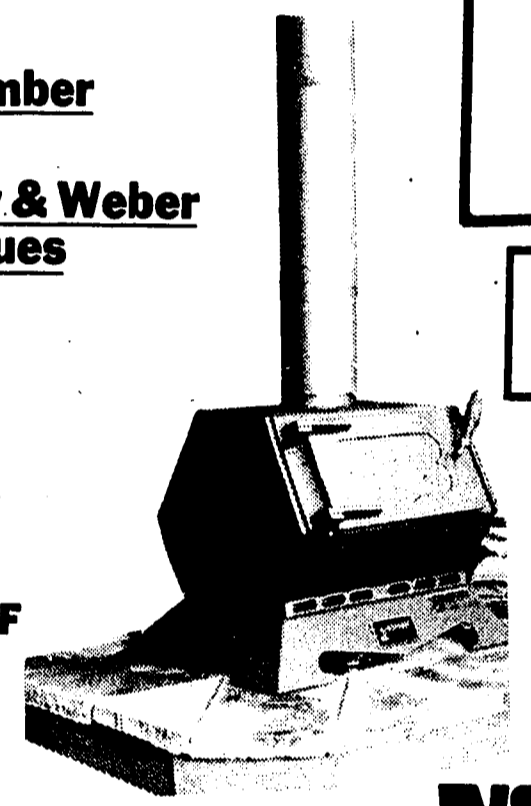

Aladdin KEROSENE HEATERS
Penny Pincher

Tropic S-181	Temp-Rite 9 S-381	Equator S-581
7,800 BTU's per hour (1,965 Kcal)	9,600 BTU's per hour	15,200 BTU's per hour
\$149⁹⁵	\$179⁹⁵	\$199⁹⁵

5 Gallons of Kerosene FREE
With the purchase of any Aladdin Heater thru 10/24

Bulk Kerosene \$1.85 Gal.

Valmun 21R-MH

Mobile Home Stove \$575
Erik Fireplace Insert \$795

NORDIC STOVE

The Hot Blast® Add-On Furnace \$725

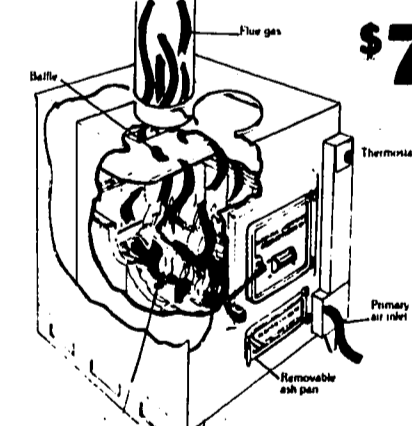

Tri-Fuel combustion chamber—wood, coal (Bituminous & Anthracite)

IRONSMITH STOVES

- Smart Looks
- 73.8% Efficient
- Safety Engineered
- Stainless Steel Combustion Chamber
- Optional Nickel Plated Door

\$449

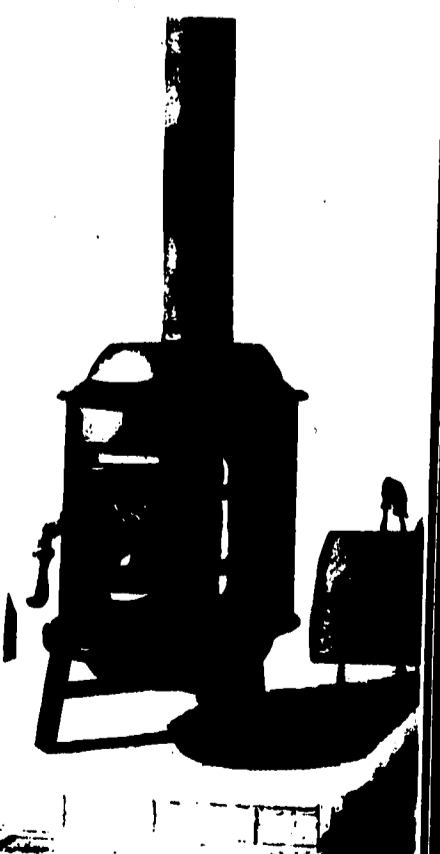

Timberlane Lumber Co., of Novi

42780 W. TEN MILE ROAD
NOVI, MICHIGAN 48050
PHONE (313) 349-2300

HOURS:
Mon.-Thur. 8:00-6:00
Fri. 8:00-8:00
Sat. 8:00-5:00
Sun. 10:00-3:00

Sale Prices Good Thru 10-24-82



We Invite You to Compare Our Quality & Price

We're Slicing Prices on our Complete Selection

(including New Fall Arrivals)

Here Are A Few Of The Specials!



LADIES' Designer Jeans

Chic Jeans Now **\$24⁹⁹**

Lee Jeans Now **\$24⁹⁹**

Calvin Klein & Jordache Jeans Now **\$34⁹⁹**



We've Got SKIRTS

Wool blend skirts by Swartz
Reg. \$34.00-\$39.00
Now From **\$26⁹⁹**

Styles? You Bet...

Crystal Pleet, Plaids, Dirndl skirts that button down in the front with pockets, in camel & olive, Dirndl Aztec stripes, corduroy button downs in camel & browns.



Intervisions by Ship & Shore

Beautifully co-ordinated

Blazers Now From **\$49⁹⁹**
Reg. \$80-\$62

Skirts Now From **\$21⁹⁹**
Reg. \$28-\$30

Slacks Now From **\$24⁹⁹**
Reg. \$30-\$32



SHIP & SHORE

Blouses

Reg. \$19-\$33

Now **\$14⁹⁹-\$26⁹⁹**

Ladies' Dresses

In Northville & Rochester **40% OFF**

Fritzie Praire Skirts
Reg. \$30-\$31 From **\$19⁹⁹**

Special Rack Sale

Selected Items

1/2 Price

All Playtex & Maidenform

20% OFF

LADIES' BARREL

Crew Neck Sweaters

70% Acrylic, 30% Wool, Berry, Grape, Cream, Gray, Pink, Camel

Reg. \$24.00 Now **\$18⁹⁹**



LADIES' Sweaters From **\$17⁹⁹**
Reg. \$22-\$42

By Northern Isle, Daddy's Money, Billie Jo, Over the Rainbow

GIRL'S Elastic Bottom Slacks

Sizes 7-14 Grape, Camel, Blue & Hunter Green

Reg. \$20.00

Now **\$15⁹⁹**



Girl's Crew Neck Sweaters

Reg. \$18.00

Now **\$13⁹⁹**

CARTER'S Blanket Sleepers

20% OFF

BOYS' WINTER

Jackets

Reg. from \$35.00

Now From **\$21⁹⁰**

Vests

Reg. from \$28.00

Now From **\$26⁹⁰**

BOYS' SIZES 8 to 14

Pants From **\$13⁹⁹**

Reg. \$18 to \$23.00

By Rifle, Lee Jeans, Levi's Corduroy, Billy the Kid

BOYS'

Shirts & Velours

By Wonder Knit & Campus

Reg. \$11 to \$24.00

From **\$8⁹⁹**



MEN'S DeeCee Flannel Shirts

Reg. \$18.00 **\$13⁹⁹**

DeeCee Heavy Weight 9 oz. Alaskan Flannels

Reg. \$22.00 **\$17⁹⁹**



MEN'S CAMPUS, SATURDAY & WILDERNESS

Sweaters & Velours

Reg. \$24 to \$36.00

From **\$18⁹⁹**



MEN'S FAMOUS BRAND LONG SLEEVE

Dress Shirts

In Blue, White, Gray, Pink, Yellow, Green & Bone

SAVE 50%

Now **\$8⁹⁹**



MEN'S POLYESTER & DOWN

Vests

Reg. \$31 to \$1.00

From **\$25⁹⁹**

MEN'S LEVI'S & SEDGEFIELD

Cords & Jeans **\$17⁹⁰-\$27⁹⁰**

Prices good thru October, 1982

Del's Department Store Formerly Brader's 141 E. Main, Northville



Del's Shoes 153 E. Main, Northville

Del's Department Store 322 S. Main, Plymouth

HOURS: Mon. - Sat. 9 to 6
Thurs. & Fri. 9 to 9

Del's His & Hers Clothing Great Oaks Mall, Rochester

Del's Shoes Great Oaks Mall, Rochester



A&P's Family Vacation Sweepstakes!

ENTER TODAY

WIN

A Family Vacation For 4 4 Days & 3 Nights Your Choice of Continental U.S. Resorts



- Head South For A Winter Vacation
- Go On A Ski Spree in the North Country



- The Winner Will Have A Choice of Continental U.S. Resort of His or Her Choosing
- Drawing to be held Friday October 29, 1982.

Here's How to Enter:

*Fill out official entry blank. Deposit at any A&P store or mail to the address shown on the entry blank. Envelope must be post marked by October 23, 1982. Additional entry blanks are available at any A&P store. No purchase necessary.
*All persons 18 years of age and older are eligible except employees or agents of The Great Atlantic & Pacific Tea Co. and their families.
*The drawing will be held on Friday, October 29, 1982. A&P will randomly select the winner at this special drawing. The winner will be notified by telephone. The winner must take trip before December 31, 1982.
*The chances of winning depend on the number of entries we receive in 62 A&P Stores and in the mail. Winners are not transferable. Not available in Ohio A&P stores.

FILL IN THIS ENTRY BLANK TODAY FOR YOUR CHANCE TO WIN

Official Entry Blank

Name _____
Address _____
City _____
State _____
Zip _____
Phone _____

FILL IN THIS ENTRY BLANK TODAY FOR YOUR CHANCE TO WIN. DEPOSIT AT ANY A&P OR MAIL TO: THE GREAT ATLANTIC & PACIFIC TEA CO., P.O. BOX 877, SOUTHFIELD, MI. 48034

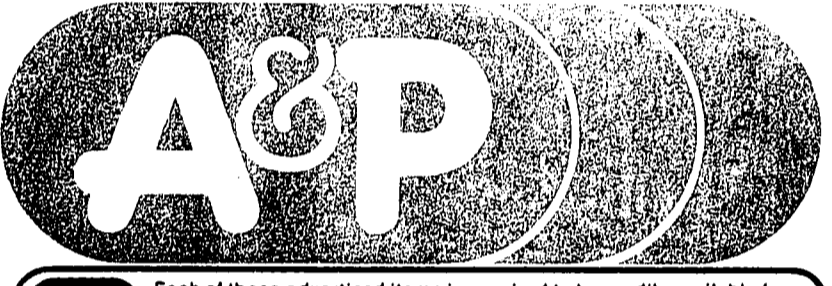

DOUBLE COUPONS

THROUGH SATURDAY, OCTOBER 23RD, 1982

ADVERTISED ITEM POLICY Each of these advertised items is required to be readily available for sale at or below the advertised price in each A&P Store, except as specifically noted in this ad.

Good on Manufacturers' Cents-Off Coupons up to and including 50¢. Does not apply to A&P or Free Coupons or where the total exceeds the price of the item. All Coffee, Cigarettes, Tobacco, Alcoholic Beverages, Ham, Turkey and Hamburgers Coupons excluded. All coupons more than 50¢ or whose total exceeds the price of the item will be redeemed for face value. Limit one coupon for any one product.

ITEMS & PRICES EFFECTIVE THRU SATURDAY, OCT. 23RD, 1982. QUANTITY RIGHTS RESERVED.

FRESH-BACKS ATTACHED

Fryer Legs

5-lbs. or more

39¢

lb.

SMOOTH ROUND, LARGE JACK-O-LANTERN

Pumpkins

99¢

ea.

TAB, SPRITE OR
Coke
2 liter bottle **1.109** plus deposit

GRADE "A" FRESH
Large Eggs
49¢ dozen
WITH *5 ADDITIONAL PURCHASE AND COUPON INSIDE

Your Choice!

ALL VARIETIES
Duncan Hines Cake Mix
69¢ 18.5-oz. box
WITH *5 ADDITIONAL PURCHASE AND COUPON INSIDE

GRANULATED
Big Chief Sugar
89¢ 4.4-lb. bag
WITH *5 ADDITIONAL PURCHASE AND COUPON INSIDE

SHOP A&P IN: NORHTVILLE, NOVI, or WALLED LAKE

42475 W. 7 MILE 418000 W. 10 MILE 1154 E. WEST MAPLE

Our Pledge

QUALITY WE UNCONDITIONALLY GUARANTEE THE QUALITY OF EVERYTHING WE SELL OR YOUR MONEY BACK AND WE'RE SO SURE OF THE QUALITY OF OUR MEATS, PRODUCE AND DELI PRODUCTS, WE'LL DOUBLE YOUR MONEY BACK WITH PROOF OF PURCHASE IF YOU ARE NOT SATISFIED WITH THESE ITEMS.

PRICE IF ANOTHER SUPERMARKET'S CURRENT NEWSPAPER ADVERTISED PRICE IS LOWER THAN OUR ADVERTISED PRICE ON AN IDENTICAL ITEM, JUST BRING IN THE AD AND WE WILL MATCH THE PRICE!

PRICE+QUALITY=VALUE

Guaranteed Value

Super Coupon

ASSORTED VARIETIES
Duncan Hines Cake Mixes

69¢ 18.5-oz. box

Limit 1 with this coupon & additional \$5.00 purchase. Limit one coupon per customer. Valid thru Saturday, October 23rd, 1982. 699

Super Coupon

GRADE "A"
Large Eggs

49¢ dozen

Limit 1 with this coupon & additional \$5.00 purchase. Limit one coupon per customer. Valid thru Saturday, October 23rd, 1982. 698

Super Coupon

GRANULATED
Big Chief Sugar

89¢ 4.4-lb. bag

Limit 1 with this coupon & additional \$5.00 purchase. Limit one coupon per customer. Valid thru Saturday, October 23rd, 1982. 697



Start The Baking Season Off Right...



A-h-h-h... Can't you just smell those homemade cookies, cakes, breads and pies? A&P has stocked the shelves for all your baking needs! ••

The Butcher Shop
with supermarket prices

ADVERTISED ITEM POLICY: Each of these advertised items is required to be readily available for sale at or below the advertised price in each A&P Store, except as specifically noted in this ad.

Prices Effective thru Saturday Oct. 23, 1982. Quantity Rights Reserved.

- Baking Center!**
- Crisco Shortening 3 lb. can **2.39**
 - Crisco Oil 48-oz. bot. **2.39**
 - Duncan Hines Brownie Mix 22.5-oz. box **1.59**
 - Pillsbury Quick Breads 14-17-oz. box **1.63**
 - Baker's Joy Pan Spray 4-oz. can **1.77**
 - A&P Evaporated Milk 13-oz. can **59¢**

Get a \$300 Refund BY MAIL

When you buy all six brands pictured BUY: Any size flavor of all six participating brands.

Enclosed are my proofs of purchases from all six participating brands plus a cash register tape with the purchase price of the six brands circled. Please mail my \$3.00 refund to:

NAME: _____
ADDRESS: _____
CITY: _____
STATE: _____ ZIP CODE: _____
AREA CODE: _____ TELEPHONE: _____

Place in stamped envelope and mail to:
BAKING BONANZA \$3.00 REFUND OFFER
P.O. BOX 9700
MAPLE PLAIN, MINNESOTA 55348

Please note these additional terms: 1. Offer good only in U.S.A. 2. This certificate may not be mechanically reproduced and must accompany your request. 3. Limit one refund per name or address. 4. Your offer rights may not be assigned or transferred. 5. Offer good from September 20, 1982 to October 30, 1982. 6. Please allow 6-8 weeks for delivery.

- Grocery Specials**
- JANE PARKER SPLIT TOP WHITE OR Split Top Wheat Bread 24-oz. loaf **1.29**
 - NABISCO Ritz Crackers 16-oz. box **1.49**
 - NABISCO CHOCOLATE SANDWICH Oreo Cookies 19-oz. pkg. **1.89**
 - CONFECTIONERS DARK OR LIGHT BROWN Domino Sugar 1-lb. pkg. **77¢**
 - ALL PURPOSE Ann Page Flour 5-lb. bag **99¢**
 - Treesweet Orange Juice 48-oz. can **1.25**
 - A&P Macaroni & Cheese 7.25-oz. box **39¢**
 - A&P-IN OIL OR WATER Chunk Light Tuna 6.5-oz. can **89¢**
 - WITH RAISINS Heartland Cereal 18-oz. 1.47
 - WHEATBALLS-FRANCO AMERICAN Spaghetti-O's 14.4-oz. can **75¢**



- SHEER STRENGTH Glad Trash Bags 15 ct. pkg. **1.93**
- FABRIC SOFTENER Toss N' Soft 20 ct. **99¢**
- SHEER STRENGTH Glad Tall Kitchen Bags 20-ct. pkg. **1.69**
- Purina Cat Chow 4-lb. bag **3.58**

Coke or
TAB. REG. & SUGAR FREE SPRITE
SUGAR FREE SQUIRT & DR. PEPPER
PLUS DEPOSIT

2.29 1/2-ltr. btl.

Boneless Chuck Roast
SOLD AS ROAST ONLY

1.58 lb.

USDA CHOICE BEEF

- Chuck Cube Steak lb. **1.78**
- Boneless Stew Beef Sold As Stew Beef Only lb. **1.88**
- Smoked Liver Sausage Whole or Half Stick lb. **59¢**
- Market Brand Sliced Bacon lb. **1.38**

Lamb Shoulder Roast

98¢ lb.

Eight O'Clock Bean Coffee
FRESH, CUSTOM GROUND

1.99 1-lb. bag

With In-Store Coupon

Boneless Chuck Steaks
SOLD AS STEAK ONLY

1.68 lb.

USDA CHOICE BEEF

Ground Chuck Hamburger
10-LBS. OR MORE

1.47 lb.

Fresh Spare Ribs
3-LB. AVERAGE

1.47 lb.

- WHOLE LEG Leg-O-Lamb lb. **2.19**
- LAMB Shoulder Blade Chops lb. **1.89**
- Lamb Loin Chops lb. **3.99**
- Lamb Rib Chops lb. **3.89**
- Ground Lamb Patties lb. **1.69**
- THORN APPLE VALLEY POLISH, BEEF, HOT OR Smoked Sausage lb. **2.28**
- THIN SLICED Land-O-Frost Lunch Meat 8-oz. pkg. **1.18**
- FLAT CUT 1.75 LB. Gunsberg Corned Beef Cut lb. **1.58**
- GRILLMASTER Chicken Franks 1-lb. pkg. **89¢**

- Dairy Foods**
- VEGETABLE-QUARTERED Ann Page Margarine 3 1-lb. ctn. **\$1**
 - CHILLED A&P Orange Juice 64-oz. btl. **1.69**

- Dairy Foods**
- ORIGINAL, SMOKY BACON, ONION & GARLIC Win Schuler Bar-Schaeze 8-oz. pkg. **1.49**
 - A&P HOMESTYLE OR BUTTERMILK Texas Style Biscuits 12-oz. pkg. **2.89¢**

- Frozen Foods**
- ALDON'S White Bread Dough 5 1-lb. loaves **1.39**
 - BEEF OR CHEESE Hormel Burritos 16-oz. pkg. **1.99**

- Frozen Foods**
- Ann Page Jelly Donuts 11-oz. pkg. **89¢**
 - Ann Page Onion Rings 16-oz. pkg. **99¢**

Fresh Fryer Legs
5-LBS. OR MORE-BACKS ATTACHED

39¢ lb.

Ketchup
VINE-RIPE

99¢ 32-oz. btl.

Scottowels
ARTS & FLOWERS

79¢ 1 roll pkg.

Lowfat Dannon Yogurt
CHOOSE FROM 11 VARIETIES

2 8-oz. cups **99¢**

Valu Homogenized Milk

1.79 plastic gallon

Sealtest Frozen Yogurt
ASSORTED FLAVORS

1.29 qt. ctn.

Natural Sun Orange Juice
HIGH OR LOW PULP

99¢ 12-oz. can

- THORN APPLE VALLEY Turkey Ham Halves lb. **1.98**
- ALASKAN Snow Crab Leg Clusters lb. **2.98**
- FRESH Pan Ready White Fish lb. **1.68**
- MARVAL DRUMSTICKS OR Turkey Wings lb. **59¢**
- TENNESSEE FAMILY PACK Small Link Sausage lb. **2.58**

A&P

THE FARM

AT A&P

For Freshness & Savings

ADVERTISED ITEM POLICY

Each of these advertised items is required to be readily available for sale at or below the advertised price in each A&P Store listed on page one of this circular.

Items & Prices Effective thru Saturday, Oct. 23, 1982. Quantity Rights Reserved.

P

Pumpkins

SMOOTH ROUND, LARGE JACK-O-LANTERN



Your Choice! **99¢** each

P

Apples

EXTRA FANCY-RED DELICIOUS, "NEW CROP" IN VEXAR BAGS



44¢ lb.

PASTEURIZED

Sweet Apple Cider

gal. 2.48

A&P Raisins

1.18

White Potatoes

U.S. #1

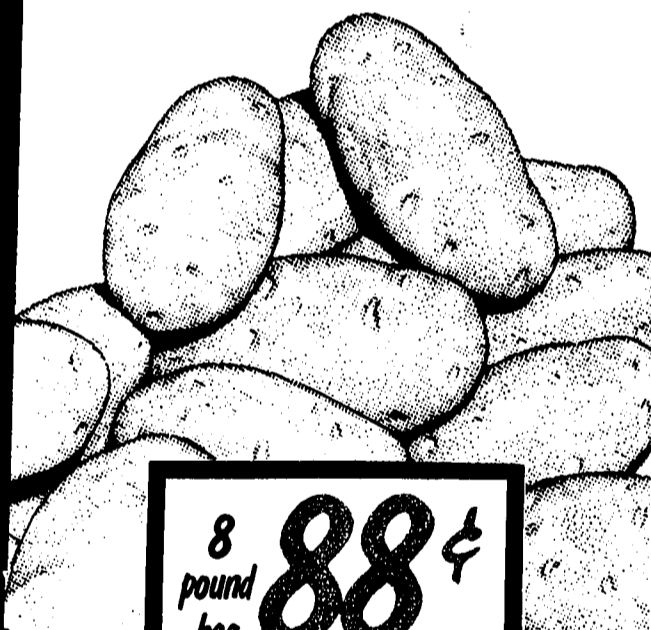

8 pound bag **88¢**

Zebra Plants

1.69

Florida Grapefruit

4.88

KW Fruit

2.88

Family Pack Tomatoes

9.99

Ivy Windmill

2.49

Tender Spinach

8.88

Crisp Carrots

5.99

Deli Specials

HBA Specials

Corned Beef
LEAN-SLICED TO ORDER

Corned Beef Sub 1.19 ea.

1.99 half pound

Old Fashion Loaf

2.99 lb.

FREE POTATO SALAD
1-lb. FREE Potato Salad with each pound of Old Fashion loaf

FRESH BAKED **Hamburger Rolls** 8 for **79¢**

AMERICAN **Potato Salad** lb. **79¢**

ANGEL FOOD **Cakes** 9-oz. pkg. **1.49**

ONION OR SALAMI **Purity Cheese** lb. **2.98**

Cinnamon or Plain Donuts DOZEN **1.79**
Available Only At Stores With Deli

NATURAL CASING **Ziggy's Hot Dogs** lb. **2.49**

BIC DEAL
Buy \$2 Worth of BIC Products and Receive a \$1 REFUND From BIC (See Store for Details)

DISPOSABLE **Bic Lighters** **59¢** each

Bic Men's Shavers DISPOSABLE

79¢ 5-ct. pkg.

KILLS GERMS ON CONTACT **Listerine Antiseptic** **2.49** 32-oz. btl.

AEROSOL **Barbasol Shave Cream** 11-oz. can **59¢**

EXTRA STRENGTH **Efferdent Denture Cleanser** 40-ct. pkg. **1.39**

ANTI-CAVITY TREATMENT **ACT Fluoride Rinse** 12-oz. btl. **1.79**

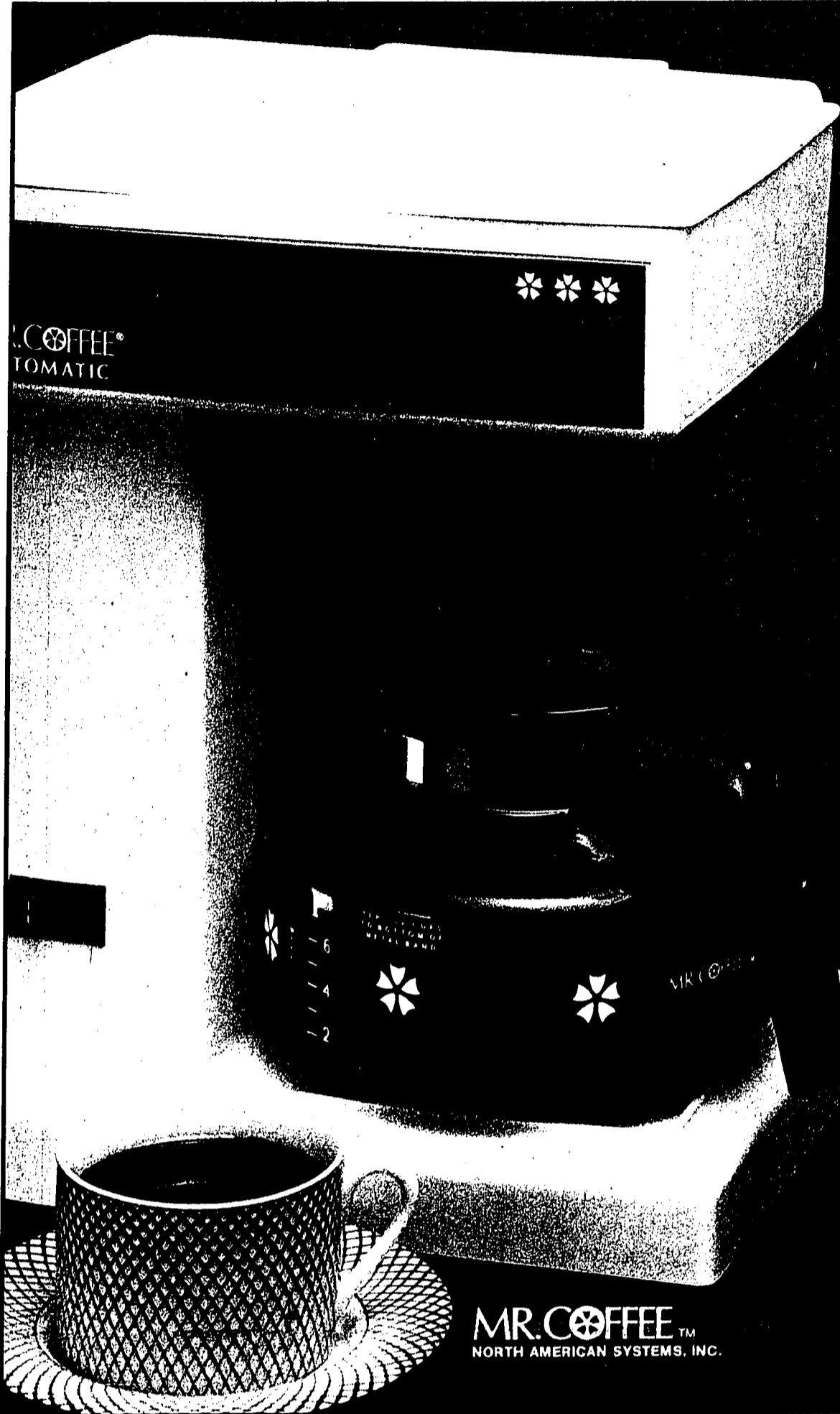

Wake up to
Mr. Coffee
and plug
into savings!

19.97

Switch to convenient, delicious automatic drip coffee with the original name in coffee makers... Mr. Coffee! Brews one to ten cups quickly and consistently. Precise temperature control gives you serving temperature every time. Disposable filter leaves you no messy clean up. So take advantage of great value and wake up to savings! #CM-1. Reg. 22.88

MR. COFFEE™
NORTH AMERICAN SYSTEMS, INC.

15¢ OFF
EXTRA ACTION
Tide
AMERICA'S FAVORITE

1.84
Tide Detergent Extra action!
Price reflects 15¢ off label. 49 oz. giant size.

Milk SNICKERS
SNACK BARS
17B.

Tempt your tricksters with taste treats!

1.78 Snack Bars A perfect treat for all your little tricksters! Milky Way, Snickers or 3 Musketeers. 16 oz.



2 SETS 1.00 save 25%
Drip-dry Hangers Set of 6 plastic coated hangers. Reg. .67 set

.86
Gillette Cricket Lighters 3-Pack No-flare, disposable.

6¢ OFF
Coast
Refreshing deodorant soap. Price reflects 6¢ off label. 5 oz.

2.17
Collegeville Children's Halloween Costumes Clown, Devil, Princess, Skeleton, Witch, Werewolf or Monster outfits. Fabric complies with U.S. legal standards of safety. Sizes S-M-L. Reg. 2.67 ea.

TG&Y

Items Available In All TG&Y Stores

2.37 save 20%

Collegeville Spooky Spooks Costumes
Pick a spook from Devil, Ghost, Skeleton, Witch, Monster, Vampire, Gorilla, Spider, Lizard Lady or Mummy. Flame retardant. Children's sizes S-M-L. Reg. 2.97 ea.

4.27

Collegeville Universal Monster Costumes
50% rayon/50% vinyl film fabric complies with U.S. legal standards of safety. Wolfman, Dracula, Frankenstein, Bride of Frankenstein or Creature from the Black Lagoon.



Halloween value... low prices to make you howl!



6.87

Latex Monster Mask...
Frankenstein, Dracula, Mummy, Witch, or Wolfman. Adult sizes. Reg. 7.97.



.67

Halloween Black & Orange Kisses Keep plenty of treats on hand. 10 oz. bag.



1.67

Spangler Dum Dum Pops All your favorite flavors like cherry, grape and pineapple. 101 ct. bag.



.88

Cyalume Lightstick 4" stick lasts 8-12 hours. Produces eerie green glow. Safe and non-toxic.

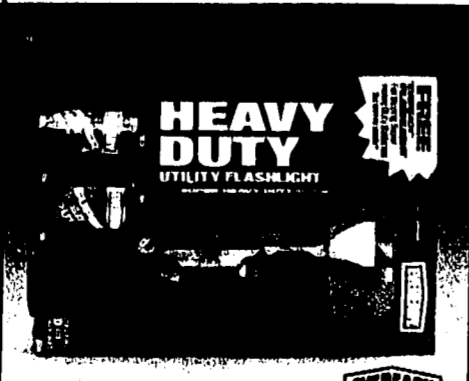

1.99

Eveready Heavy Duty Flashlight Tough polyethylene body with 2 heavy duty "D" cell batteries.



2.78 save 30%

Anchor Hocking 2 pc. Pumpkin Jar Clear glass with cover. 70 oz. Reg. 3.96

TG&Y

Items Available In TG&Y Family Centers Only



7.99

Northern Electric Pro Pistol Hair Dryer Powerful 1250 watt with 2 speeds in a compact pistol shaped case. #1878. Reg. 9.68

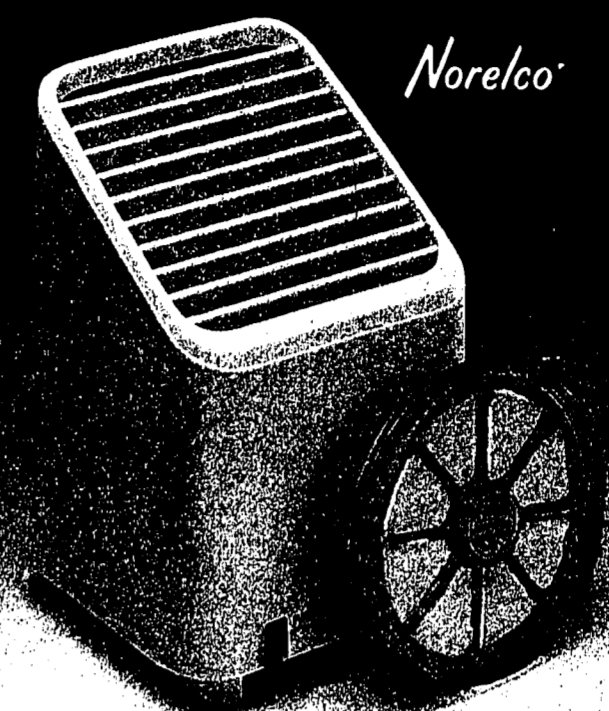

TG&Y's Low Price **15.99**
Less Mail-in Rebate* **-3.00**

Your Final Cost **12.99**
After Rebate

Norelco Clean Air Machine Helps remove tobacco smoke, cooking and other odors. #HBI900. Reg. 18.99

*Pick up coupon for \$3.00 mail-in rebate offer.



25.97

Rival Crock Pot Slow cooks, keeps nutrition in. Removable stoneware serving bowl. 5 qt. capacity. #3355V. Reg. 28.73

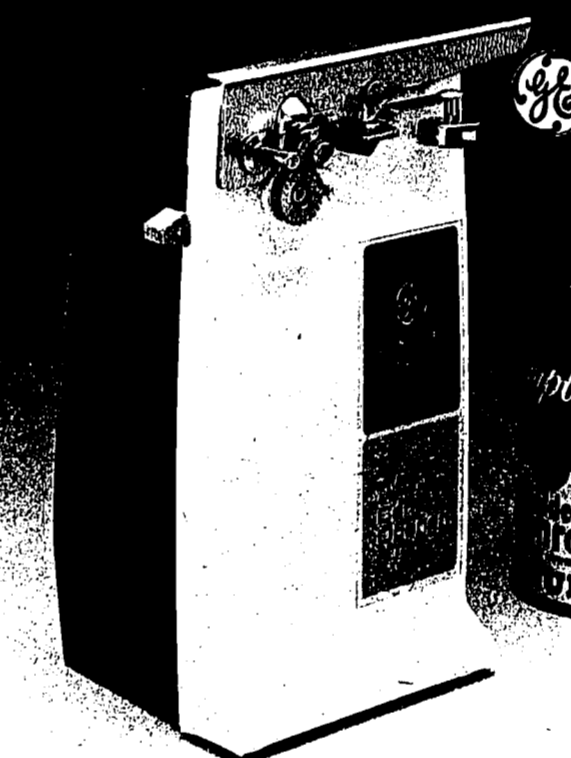

12.89

G.E. Electric Can Opener No fuss, easy to use can opener. Shuts off automatically. #EC32CA. Reg. 14.99

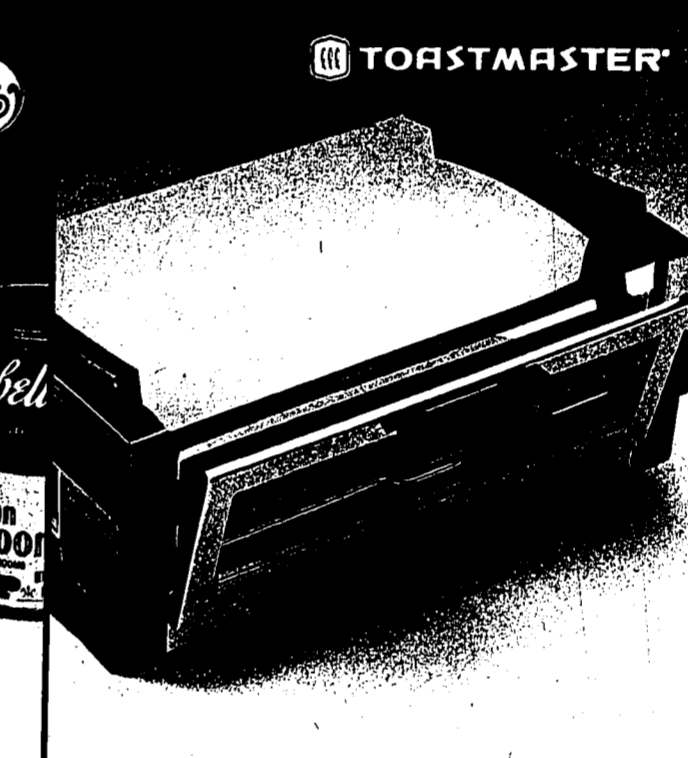

23.88

Toastmaster Oven Broiler Easy cleaning, full range thermostat. A convenient way to toast, grill or cook. #5230. Reg. 25.96

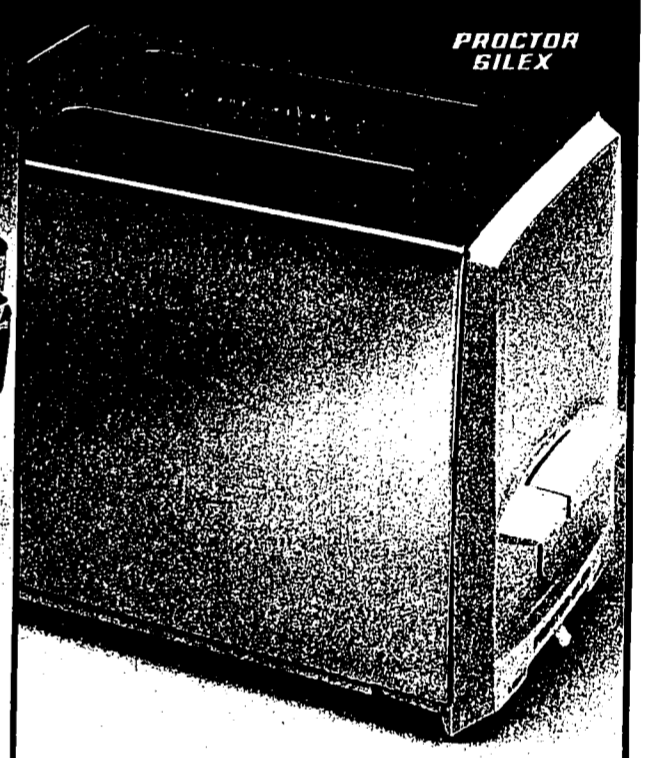

11.88

Proctor Silex Toaster From bread to pastry, you select the toasting you want, light to dark. #T620W. Reg. 13.46

Plug into appliance value... with the quality advantage!



save 3.97

9.99

Hamilton Beach 3 Speed Hand Mixer The lightweight, reliable mixer with easy grip handle and beater ejector. Thumb-dial for mixing, blending or folding selection. #97G. Reg. 13.96



12.97

Hamilton Beach Corn Popper Get consistently delicious popcorn everytime! Automatically dispenses melted butter as the corn pops! Pops up a big 4 quarts. #500G. Reg. 14.96

TG&Y family centers

Items Available in TG&Y Family Centers Only

Kodak Disc 4000 Outfit



39.97

Kodak Disc 4000 Camera Outfit A whole new way to make pictures! Ultra-compact, fits in the palm of your hand. Flash recharges and automatically flashes when you need the light! Complete with 2 discs of Kodacolor HiR film. #148-7552. Reg. 46.87. Limit 2



Items Available in TG&Y Family Centers Only

Save \$50 on quality color!



\$239

Enjoy a 13" Color Television with a full 90 sq. inches of viewing area with easy one-button color tuning. 100% solid state circuitry with inline gun-slotted mask black stripe picture tube. Take advantage of quality color at a low price... plus savings! #K1301. Reg. 289.00

The Panasonic difference on tape... in stereo!

\$157

Panasonic Stereo Radio/Cassette Enjoy quality reproduction of your favorite music! Carry it to the beach, to a party or to your own backyard. AM/FM with full cassette player/recorder capacity, 4 speakers and LED recording meters. Take advantage of sound value today! #RXS1100



24.96

save 5.01

Panasonic Cassette Recorder One touch recording, auto stop, built-in condenser mic. #RC44. Reg. 29.97



8.96

IMA Calculator This desk top 8 digit calculator has LCD readout and comes equipped with batteries. #LC750



19.97

save 6.91

AM/FM LED Clock Radio Space Saver! 100% solid state circuitry, slide rule AM/FM tuning dial, 24 hr. set and forget alarm. #E523. Reg. 26.88. Limit 2.

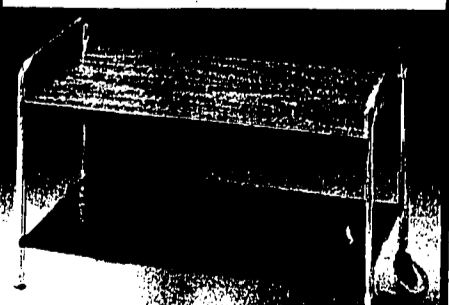

17.97

save 2.00

GUSDORF TV Cart For 19" TV. Full top and bottom shelves. Solid wood rails, disc casters, walnut tone finish. #2130. Reg. 19.97



10.97

Spartus "Polaris" LED Alarm Clock Easy to read 6" LED display, 100% solid state, snoozer alarm. AC/DC operation. #1106C1



29.97

G.E. Portable Radio AC/DC rechargeable. 2 antennae: telescoping whip for FM, built-in ferrite for AM. #7-2854

TG&Y family centers



Your Choice \$139

Soundesign Auto Racks Your choice of two beautiful cabinets. Walnut hardwood and wood veneer model with glass doors for stereo components or the Oak veneer cabinet especially for video recorder and TV. S-917W/S907K

Soundesign Super Series AM/FM receiver with the versatility of an 8 track player, turntable and a cassette player/recorder. Full feature blue/green clock and BSR record changer. 2 cube speakers. #5943CHR. Reg. 279.97

Gran Prix Trimode Cassette/Stereo System Versatile sound at a low, low priced AM/FM receiver with cassette player/recorder, digital clock and BSR record changer. 2 cube speakers. #5350. Reg. 159.97



34.96

Soundesign Musicmate Stereo Cassette With Headphones Bring great stereo into your world of jogging, biking, walking or any other leisure activity. With lightweight headphones. 14 oz. total wt. #4261



Emerson portable cassette player and rear panel audio level indicator. Semi-auto turntable, 2 matched modular speakers and more! Fits anywhere! #MC1400. Reg. 197.86

TG&Y family centers

Items Available In TG&Y Family Centers Only

Fix-up your home for less!

save 25%

4.44

TG&Y Latex Wall Paint. A bright new coat of paint can make your rooms look bigger and give your interior a fresh new look! Choose from an array of decorator colors. One gallon. Reg. 5.94

.92

TG&Y Spray Enamel. Use indoors or out. Touch up metal or wood surfaces. Dries fast. A variety of colors to select from. 11 oz. Limit 2

save 24%

5.97

Keller Wooden Stepladder. Two feet of help for all the projects and small jobs around the house. #W-2. Reg. 7.87

KELLER



Conserve energy with a new air filter

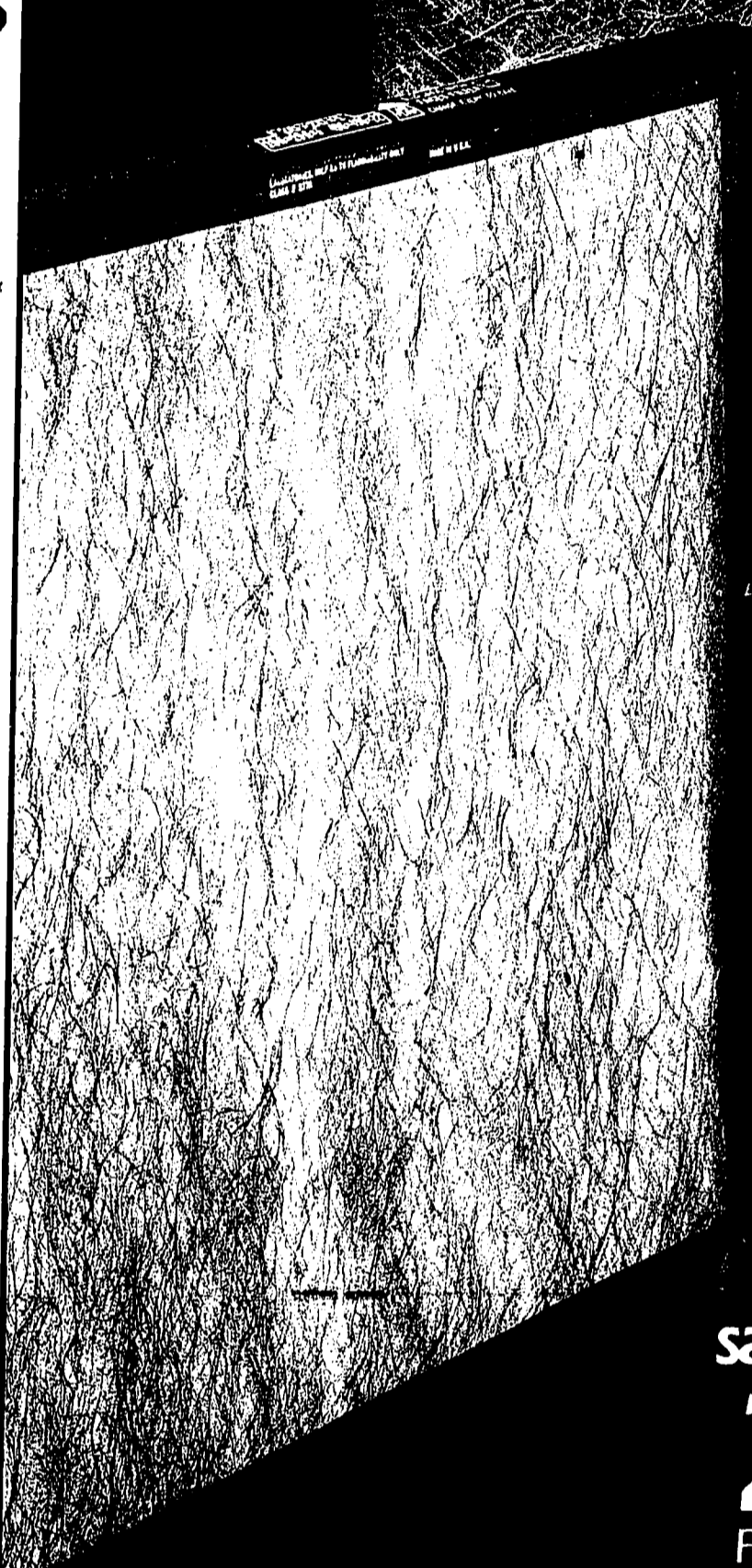

save 22%

2\$1

FOR

Fiberglass Filters. If you haven't changed the filter in your air conditioning or heating system lately, you're probably wasting fuel and money! Sizes from 10x20x1" to 20x25x1". Reg. .64 ea.

Items Available In All TG&Y Stores

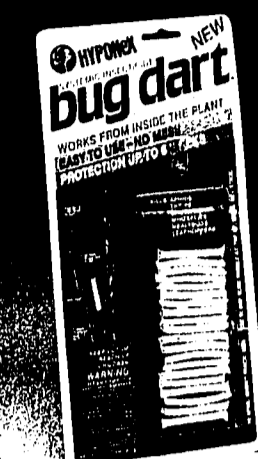

2.96

Hyponex Bug Dart. The insecticide that protects the total plant. Absorbed into the roots, lasts up to 6 weeks. 20 ct.



save 32%
2 \$1

PKGS.
Easy Wipe Strong, economical cloths. Rinse clean, wash out and use again. 13x24" in assorted colors. 8 ct. Reg. .73 pkg.



1.67

Liquid-Plumr Heavy duty drain opener. Big 64 oz. plastic jug.

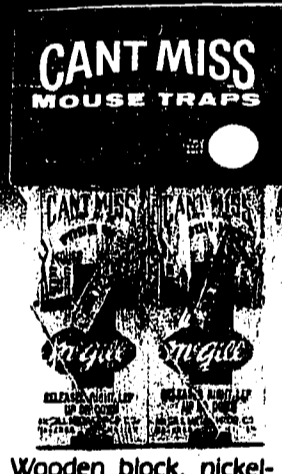

save 36%

2\$1

FOR
Mouse Traps Wooden block, nickel-plated trigger, copperized coil spring. 4x1 1/2". Reg. .78 ea.



2.88

save 42%

Pacific Electriccord Reflect-O-Clamp Lamp. Holds firm and adjusts to any position without tools. 6' cord. Reg. 4.97

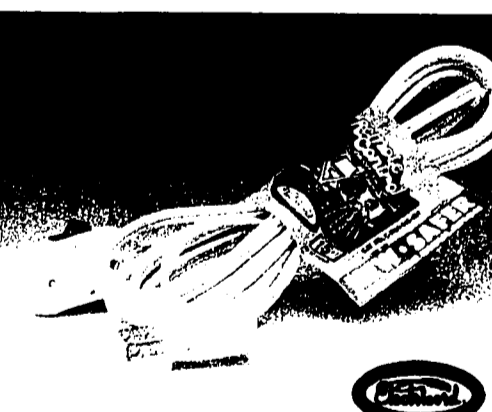

2.22

Pacific Electriccord Remote Control Extension Cord. Easy to use on-off switch. 15' long. 50% more insulation.

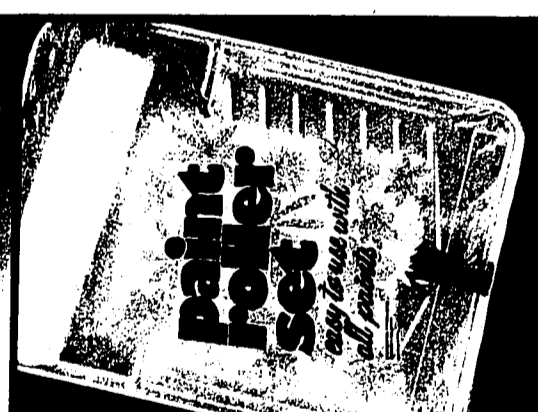

1.76

save 50%

Paint Roller Set 9" roller and cover with metal tray. Use with all paints. Reg. 3.49

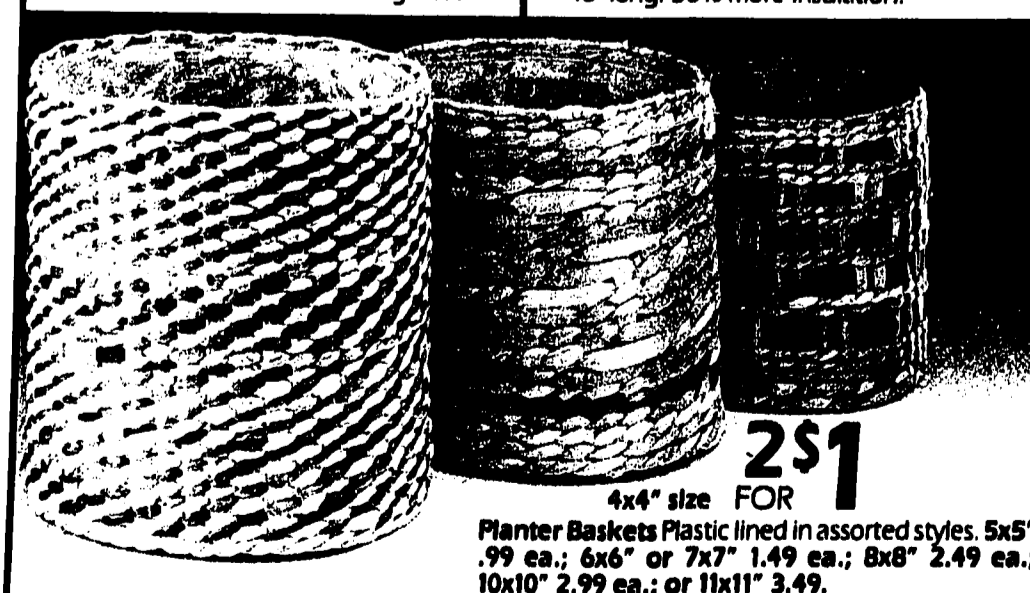

2\$1

FOR
4x4" size
Planter Baskets Plastic lined in assorted styles. 5x5" .99 ea.; 6x6" or 7x7" 1.49 ea.; 8x8" 2.49 ea.; 10x10" 2.99 ea.; or 11x11" 3.49.

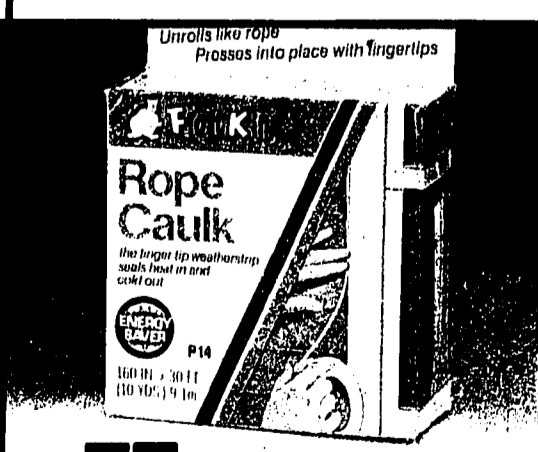

.77

save 25%

Frost King Rope Caulk. The fingertip weatherstrip. Seals heat in and cold out. Roll is .160"x30'. Reg. 1.03

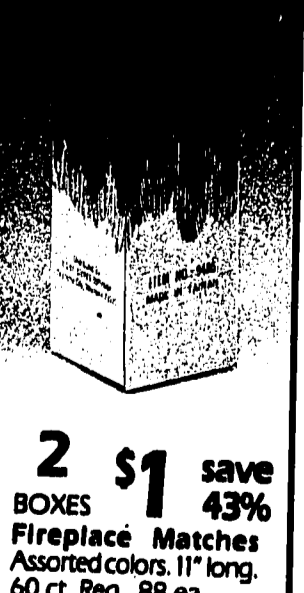

2 \$1

save 43%

BOXES
Fireplace Matches Assorted colors. 11" long. 60 ct. Reg. .88 ea.



3.88

Angler Broom Unique design helps get the dirt other brooms miss. Long lasting, washable. Reg. 4.36

2.99

save 54%

Wet Mop Power Strip Strong and absorbent yarn. Replaceable mophead. Reg. 6.47.

1.99

Royal Maid Hand! Sponge Mop. Wooden handle. A product made by the blind.

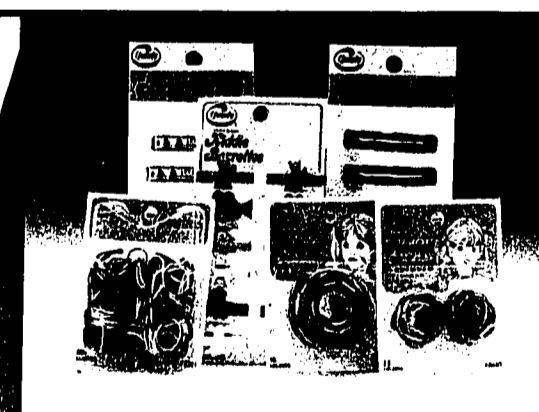

2 \$1

FOR
Your Choice Hair Care Accessories Choice of Barrettes, Kiddle Barrettes, Metal Barrettes and assorted Ponytail Holders.



1.36

Scotch Brand Magic Tape "Magic" transparent tape, 1/2" wide x 800" long. 2 rolls per package.

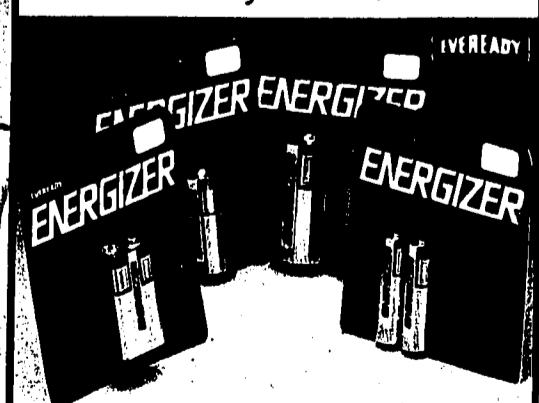

1.36

save 45%

Eveready Energizer Batteries Long life alkaline for all uses. "C" or "D" cell, 2 per pkg.; "AA" cell, 2 per pkg.; or one 9 volt. Reg. 1.97 pkg.



4.96

BASF C-90 Cassette 3-Pack 90 minute performance tapes. Reg. 5.97

TG&Y family centers

TG&Y

Items Available In All TG&Y Stores

Your Value Advantage is TG&Y!

Your cleaning advantage...quality!



.88

Purex Liquid Bleach. From laundry to kitchen to bath, Purex is your multiple-purpose household bleach! 1 gallon.

.68

Sweet-Heart Dishwashing Detergent. Washing dishes can be gentle to your hands with Sweet-Heart liquid detergent. 32 oz. size.

1.99

Downy Fabric Softener. It's concentrated! Freshens and softens clothes as it reduces static cling. Price reflects 25¢ off label. 64 oz.



save 27%
.57 bag

Candy Stock up on treats before it's too late! Choice of Tootsie Roll Pops, Dum Dum Suckers, Pixy Sticks, Tootsie Rolls, Kiddie Party Mix, Sweet Tarts, Bit-O-Honey and more! Assorted weights per bag. Reg. .78 bag



Your Choice 1.97

C135 or C110 Kodacolor II Film. Keep plenty of film on hand! 24 exposures. Limit 2 ea.



.66 save 31%

Hyponex Potting Soil pH balanced formula for full growth potential. 8 lb. bag. Reg. .96



2 \$1 save 21%

Reynolds Wrap Baking Foil Great for cooking or reheating, good for freezing, too! 81/3 yds. x 12". Reg. .63 roll

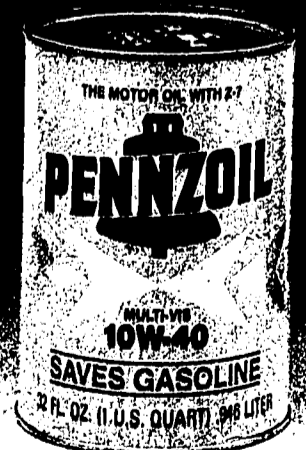

.97 qt.

Pennzoil 10W-40 Motor Oil Clean oil means a smoother running engine. Limit 6 qts.

TG&Y

TG&Y's policy is to always have advertised merchandise in adequate supply in our stores. In the event the advertised merchandise is not available due to unforeseen reasons, TG&Y will provide a Rain Check, upon request, in order that the merchandise may be purchased at the sale price when it becomes available, or you may purchase similar quality merchandise at a similar price reduction. It is the policy of TG&Y to see that you are happy with your purchases. It is TG&Y's policy to be priced competitively in the market. Regular Sale Prices may vary market by market, but the sale price will always be as advertised. We will be happy to refund your money if you are not satisfied with your purchase. VISA and MasterCard accepted.

JCPenney Fall Sale Break...
4 days only! Oct. 20th. thru 23rd.



fabulous price on all
our better Chic

Stretch
it easy.

Sweater knit
dresses for
juniors.

Special
14.99

A warming trend in
dresses that you'll
love. Cuddly soft
acrylic in three great
colors. Stylish boat
neckline with cuffed
long sleeves and tie
belt. Sizes 7-13.

Only 864 units.



Shop these JCPenney stores
Monday thru Saturday 10 a.m.
til 9 p.m., Sundays 12 to 5.

- Fairlane Town Center,
Michigan Ave. & Hubbard
- Tech Plaza,
12 Mile & Van Dyke
- Twelve Oaks Mall,
12 Mile & Novi Rd.
- Northland,
Greenfield Rd. & Hwy. 102
- Eastland,
18000 E. Eight Mile Rd.
- Westland,
Warren & Wayne Rd.
- Northwood,
13 Mile & Woodward
- Southland,
Eureka & Pardee Rd.
- Bloomfield, Miracle Mile,
Telegraph & Sq. Lake Rd.
- Lakeside,
M-59 & Schoenherr
- Oakland Mall,
14 Mile & I-75
- Grosse Pointe woods,
7 Mile & Mack
- Lincoln Park Plaza,
Fort & Emmons
- Briarwood Mall,
Ann Arbor

Some items in this book are
available only at larger JCPenney
stores, but all stores are stocked
with exciting values for you, your
home, and your family. Specials
and closeouts are available only
while quantities last. Intermediate
markdowns may have been taken.
All sale prices effective
thru Saturday.

4 days
only. It's
our big
Fall sale
with 48
pages of
exciting
savings
for all
in the
family.

Sale
starts
Wednesday,
Oct. 20th.



JCPenney



Easy
going
slacks.

Sale
11.20

Reg. \$14. Women's
pull-on polyester
pants with elastic
waistband in back.

Basic colors.
Sizes for misses
and petite sizes.
All JCPenney stores.

Women's sizes
32 to 38. Reg. \$16
Sale 12.80
Mall stores only.

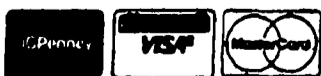
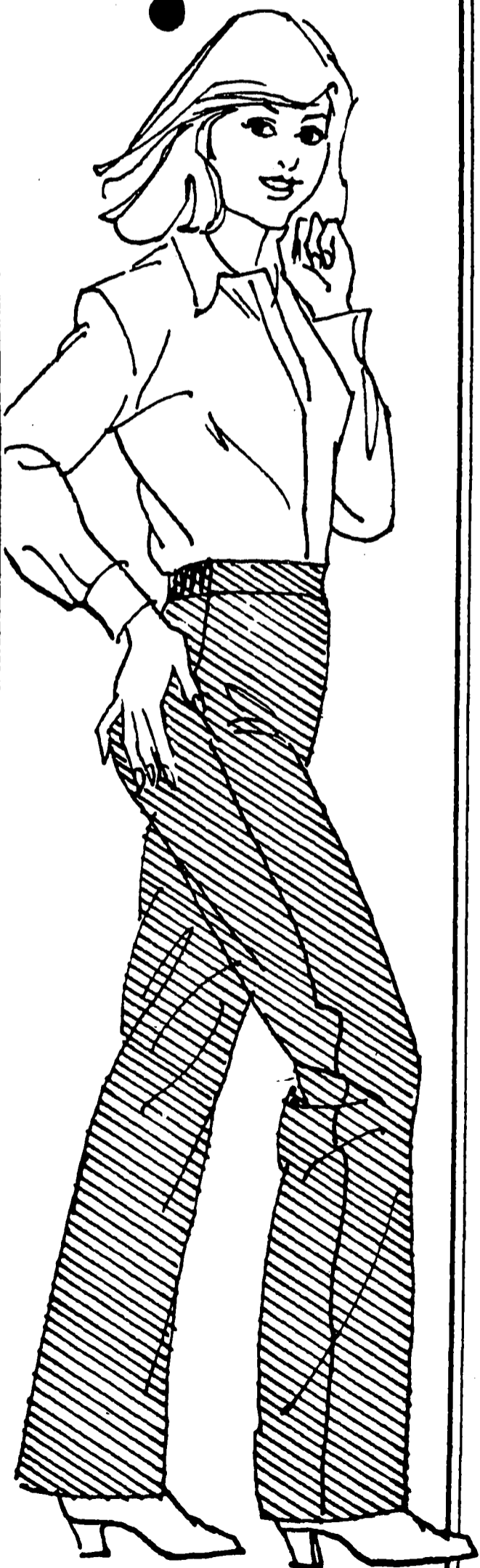

Run
for the
savings.
Misses' jogging
suits.

Sale
15.99

Orig. 19.99. Polyester/
cotton jogging suits
with hooded pullover
jacket. Pants have
elastic waistband and
knitted cuffs at
ankles. Rainbow
colors in misses'
sizes.

Only 988 total units.



JCPenney

The
cowl
neck.

A basic top
for misses.

Sale
5.99

Orig. \$13. A great
basic addition to your
wardrobe. Perfect
with skirts or slacks.
Polyester cotton knit
blend. Lots of colors.
Sizes S, M, L.

Only 1200
total units.

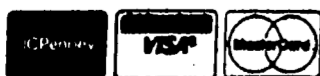

Ruffle
your
fancy.

Special
12.99

Womens Ultressa
polyester long sleeve
blouses in three
classic styles. Lots of
ruffles for a feminine
look. Soft colors in
misses sizes.
Only 1,200 units.



JCPenney

The
soft
touch
of wool.

Sale
12.99

Reg. 14.99. Misses
plaid or solid color
skirts of reprocessed
wool, polyester and
acrylic. A-line styling.
Misses' sizes.

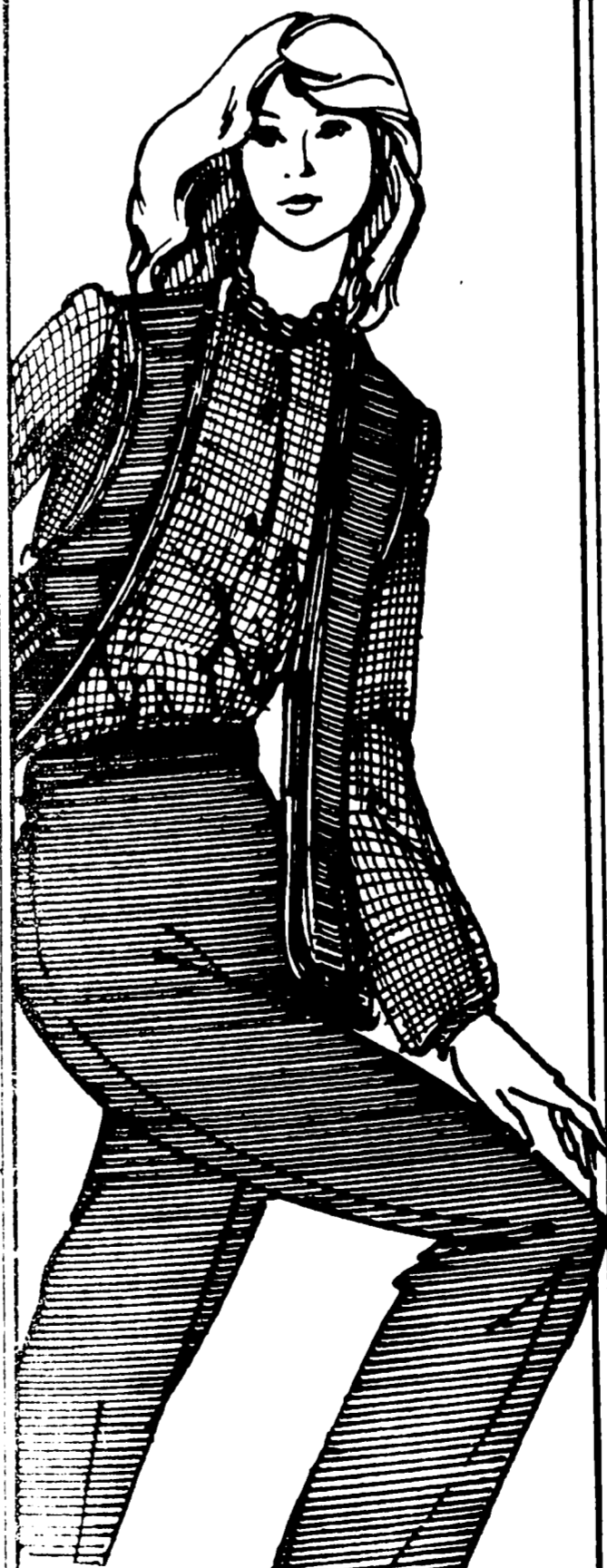
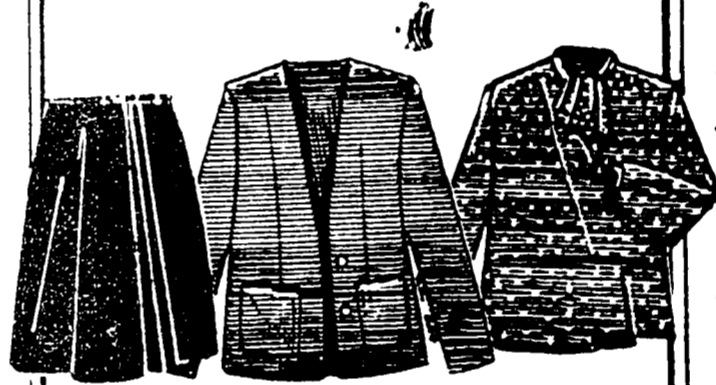
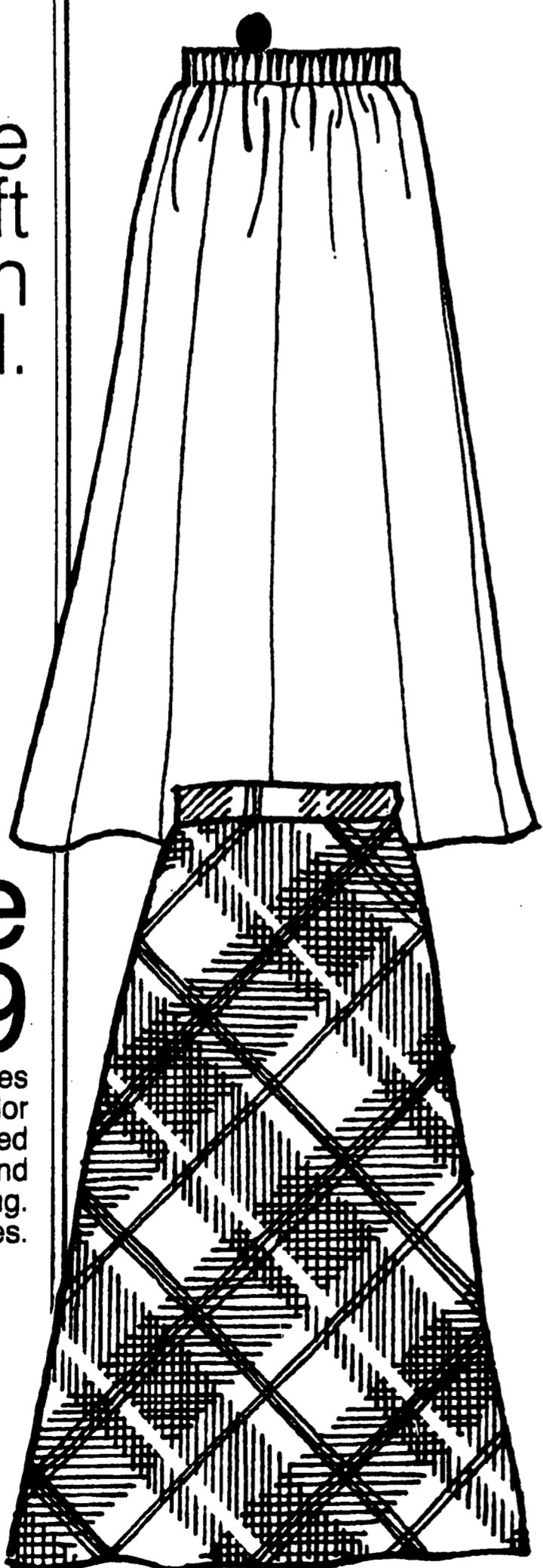

Save on
these
neat go-
togethers.
Coordinate
savings for
misses sizes.

Sale
10.99 to
19.99

Beautifully styled
polyester match-ups
perfect for casual or
dressy times. Take
your pick from slacks,
side pleat skirt,
blazer, poodle vest
and two styles of
blouses. All easy care
in sizes 8-18.

Slacks. Orig. \$16.
Sale 10.99
Skirt. Orig. \$19.
Sale 11.99
Blazer. Orig. \$30
Sale 19.99
Polka dot blouse.
Orig. \$21 **Sale 13.99**
Stripe blouse.
Orig. \$21 **Sale 13.99**
Poodle vest. Orig. \$24
Sale 15.99

JCPenney

Stay
warm.
Save
too.

Misses' acrylic
cardigan.

Sale
13.99

Orig. \$21. Womens
cuddly soft acrylic knit
sweater in bold
brights. Narrow knit
cuffs. Gathered at
shoulders.

Sizes S, M, L.
Only 915 total units.



Suitable
savings

for
juniors.

Sale
69.99

Orig. \$149. 100%
wool suits for the
career girls wardrobe.
Beautifully detailed in
stripes, herringbones
and solid colors.
Dirndl or side pleated
style skirts.
Sizes 5-13.

JCPenney Mall
stores only.

Only 433 units to sell.

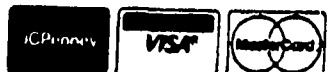
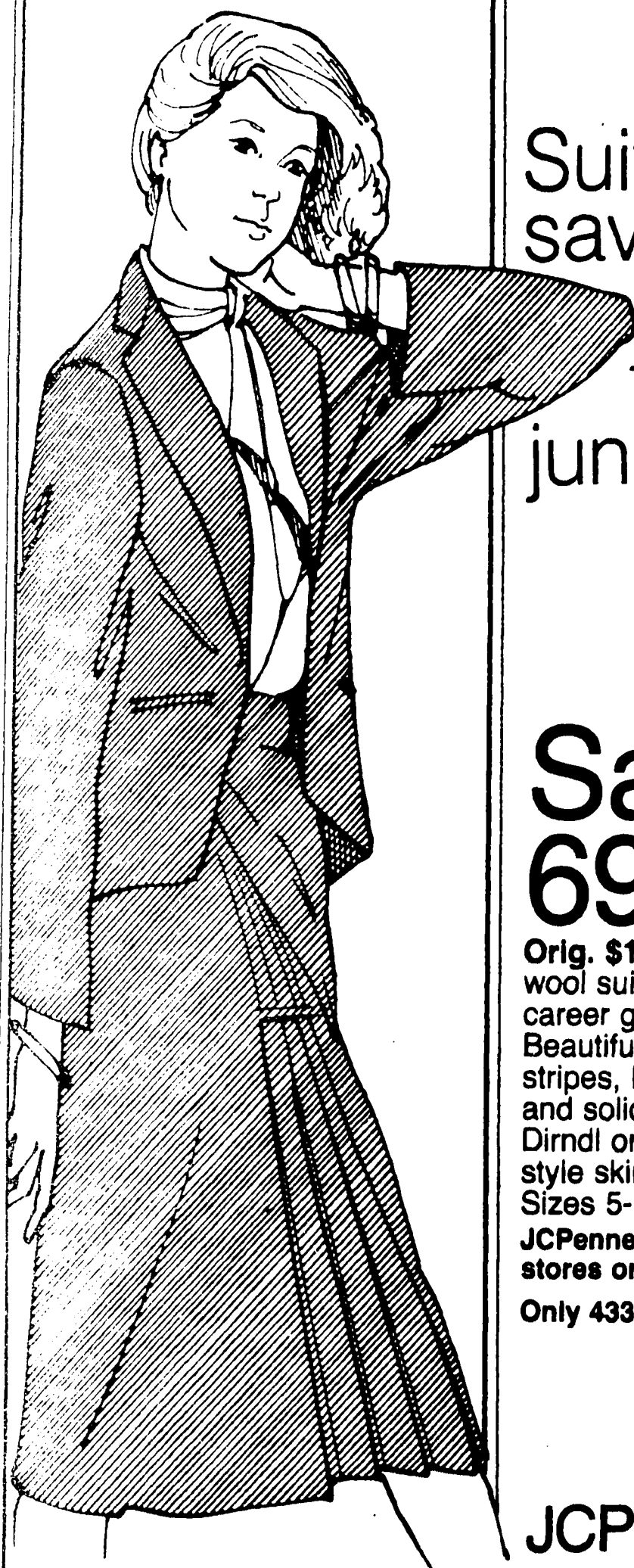

JCPenney

Citation chains.

The look of elegance at a very special low price.

Sale 1.99

Orig. \$5 to \$15. Here's the perfect finishing touch for everything in your wardrobe. Dazzling Citation™ jewelry in gold tone or silver tone chains. Now at one eye-catching price.

Limited quantities.

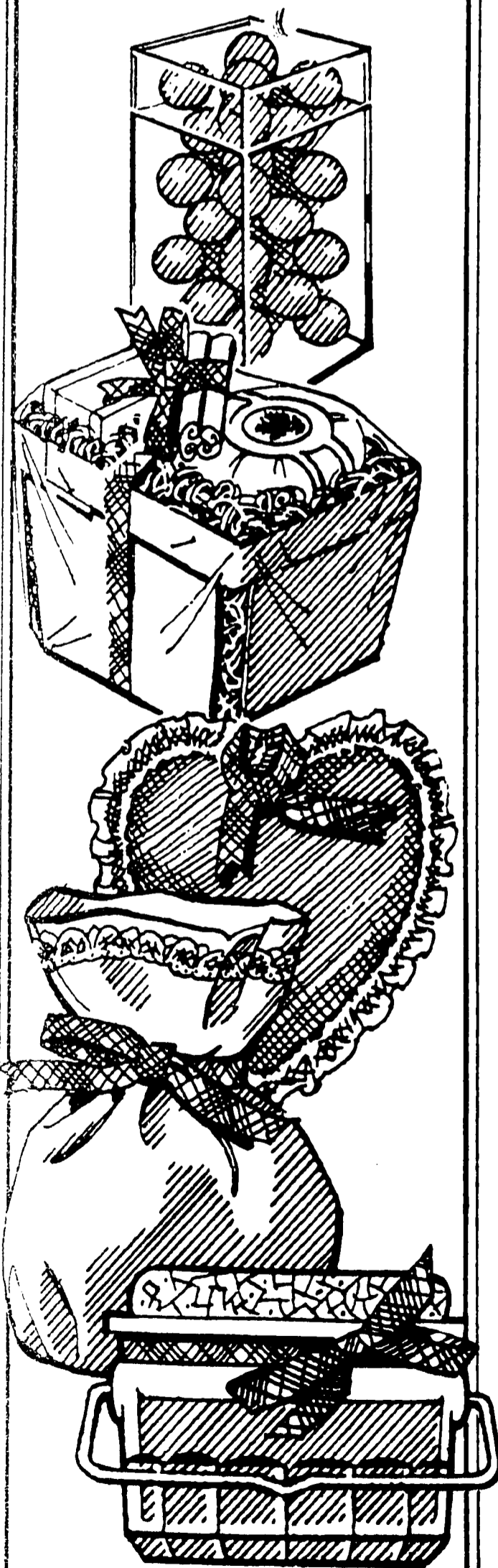
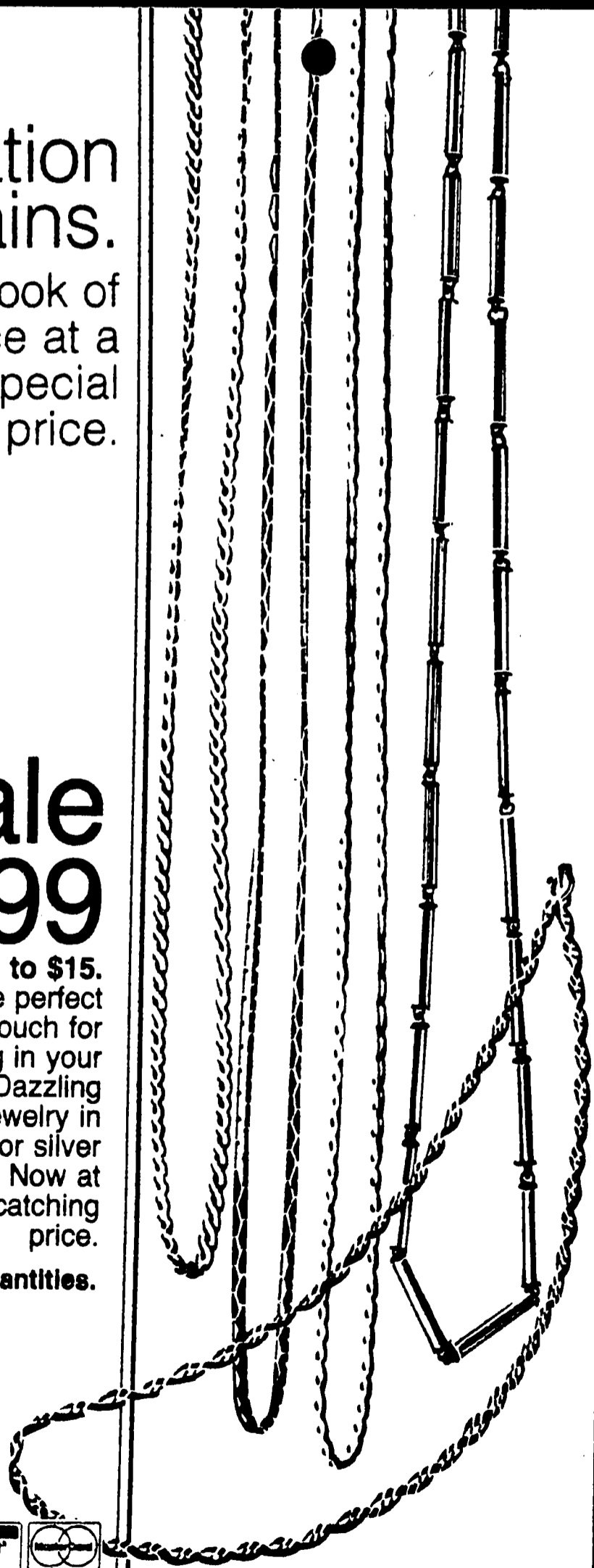
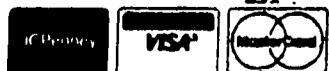

50% off Prestige Place®

Scent-sible savings.

Sale 1.50 to \$6

Orig. \$3 to \$12. Sachets, bath oil beads, candles and more. All at great savings. Many in rich velvet. Hurry in and save for yourself or as a gift for someone special.

JCPenney
Mall stores.

JCPenney

Sparkling
savings
for her.

Sale
12.99

Orig. \$15 to 37.50.
Stop in for our huge
collection of ladies
fashion rings. Styles
available in a wide
range of sizes with
the looks to
compliment any outfit.
Some set with genuine
stones. Hurry in while
our selection is at its
very best.
Limited quantities.

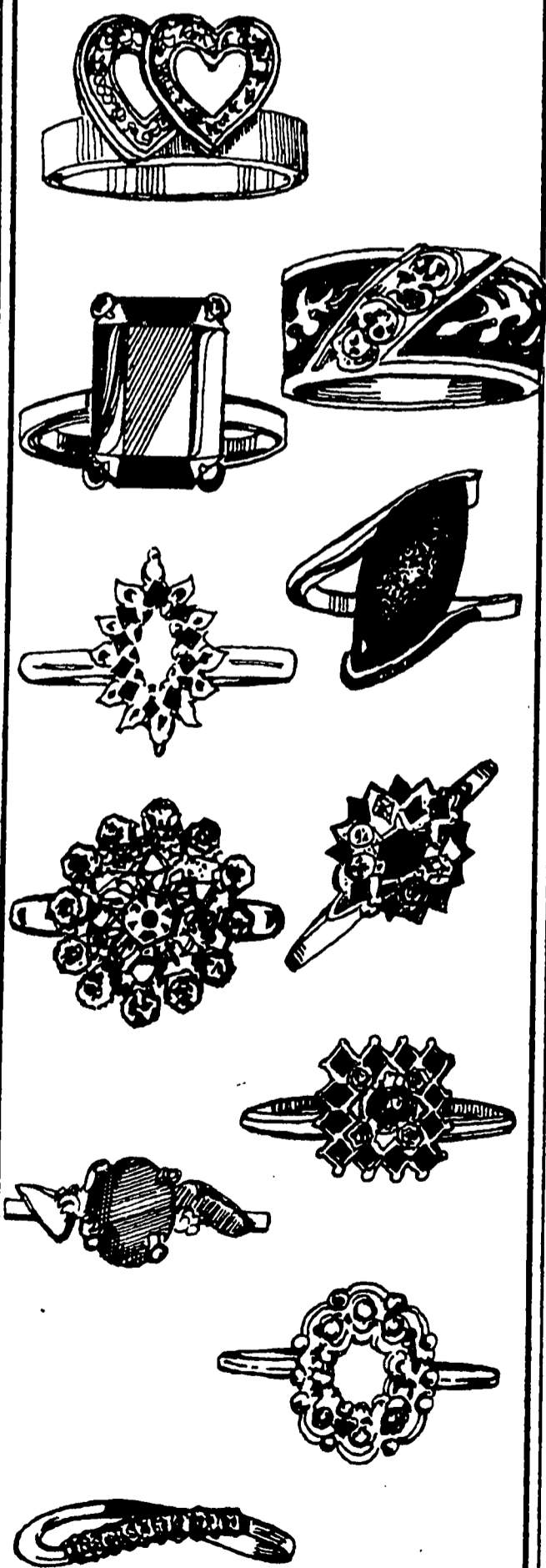
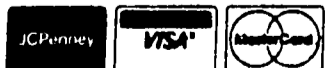

Grab
a bag.
Genuine
leather at
genuine
savings.

Sale
\$10 to
19.99

Orig. 12.50 to \$28.
Great savings are in
the bag when you
treat yourself or
someone special to
one of these
distinctive leathers.
Smooth and supple in
up to the minute
shapes. Choose from
an exciting selection
in new fall colors.
Only 784 total
units to sell.

JCPenney

**Super
cord
jeans.**
Straight legs
for girls.

**Sale
7.99**

Orig. \$14. Big girls' polyester/cotton cord jeans with front pleats. Fashion colors. Sizes 7-14 regular and slim. 930 total units.

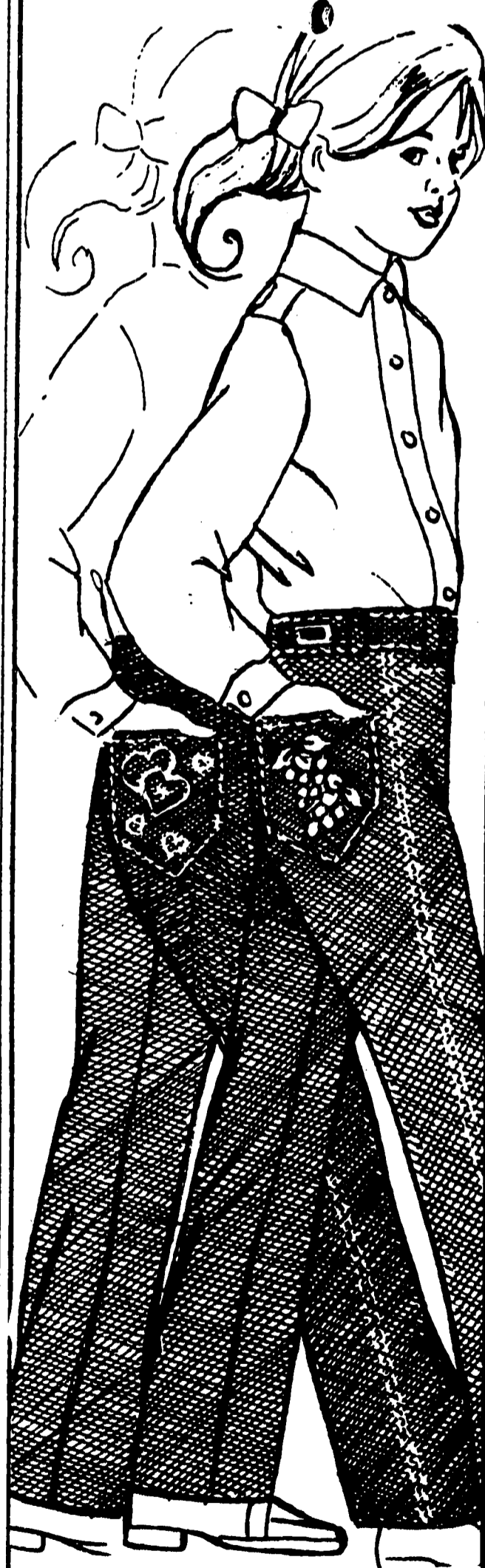
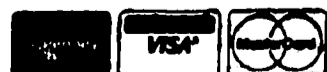
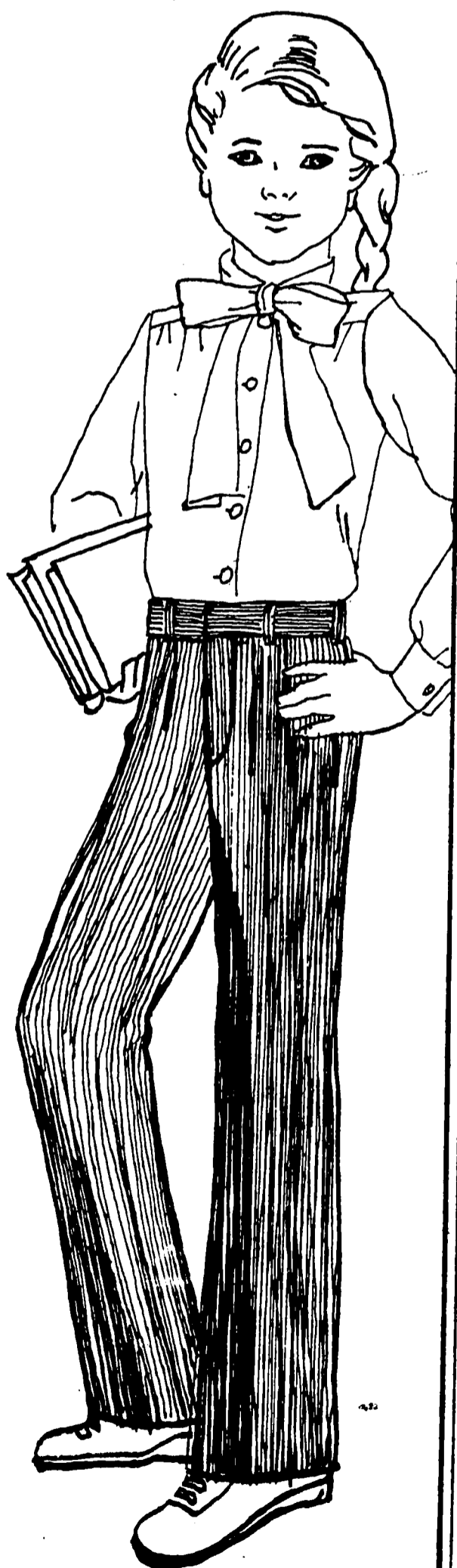

**Fancy
pants.**
"Bon Bon"
jeans
for girls.

**Sale
8.99**

Orig. \$16. Fashion jeans for girls in an easy care blend of cotton/polyester/rayon. Design on back pockets. Sizes 7-14. Only 912 units to sell.

JCPenney

Sleep
in soft
and fluffy
flannel.

**Special
7.99**

Cuddly soft print
gowns of
Flannel-Flannel II
polyester. Button
back closing. Sizes
7-14. Assorted prints.

Only 863
total units

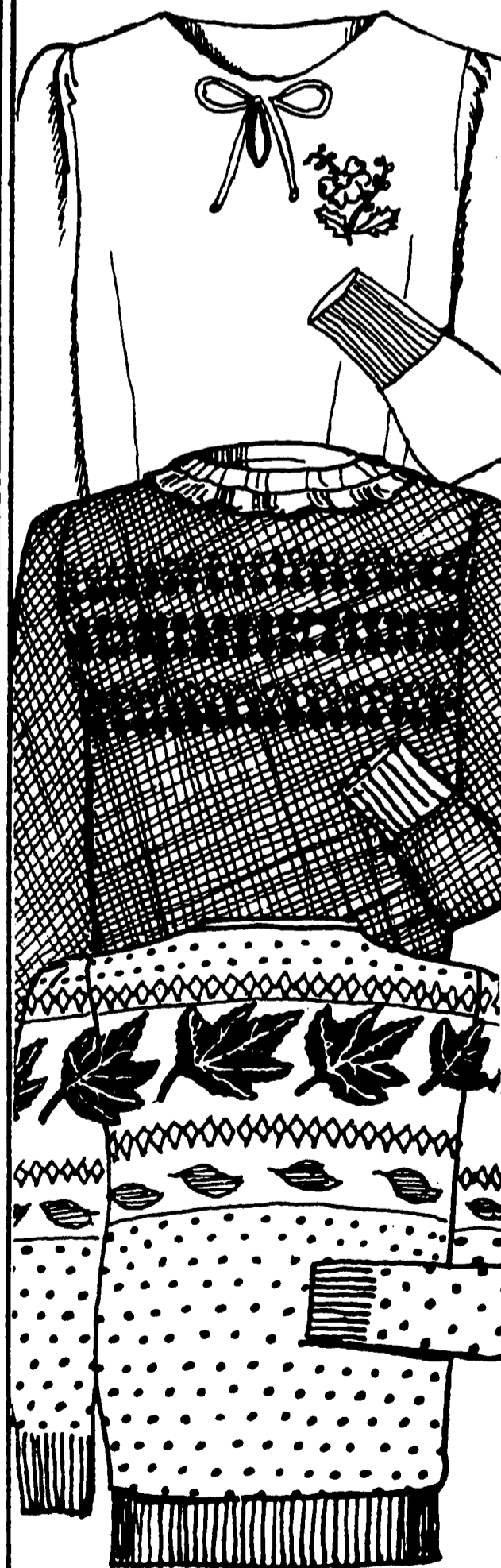

Warm
savings
for big
girls.

**Sale
7.99**

Orig. \$14 to \$15.
Take your pick from
three styles of
embroidered or
patterned sweaters.
Pullover in soft easy
care acrylic with lots
of extra trimmings.
Beautiful colors in
sizes S, M, L.

Only 1613 total
units to sell

JCPenney

Warm-up.
Ready.
Set.
Save.
Boys
warm-up
suits.

Sale
9.99

Orig. 14.99. For the action-minded boy you'll want this easy-care acrylic warm-up suit. Long sleeve jacket has zip front with contrast color trim. Pants have elastic waistband. Sizes for big boys.

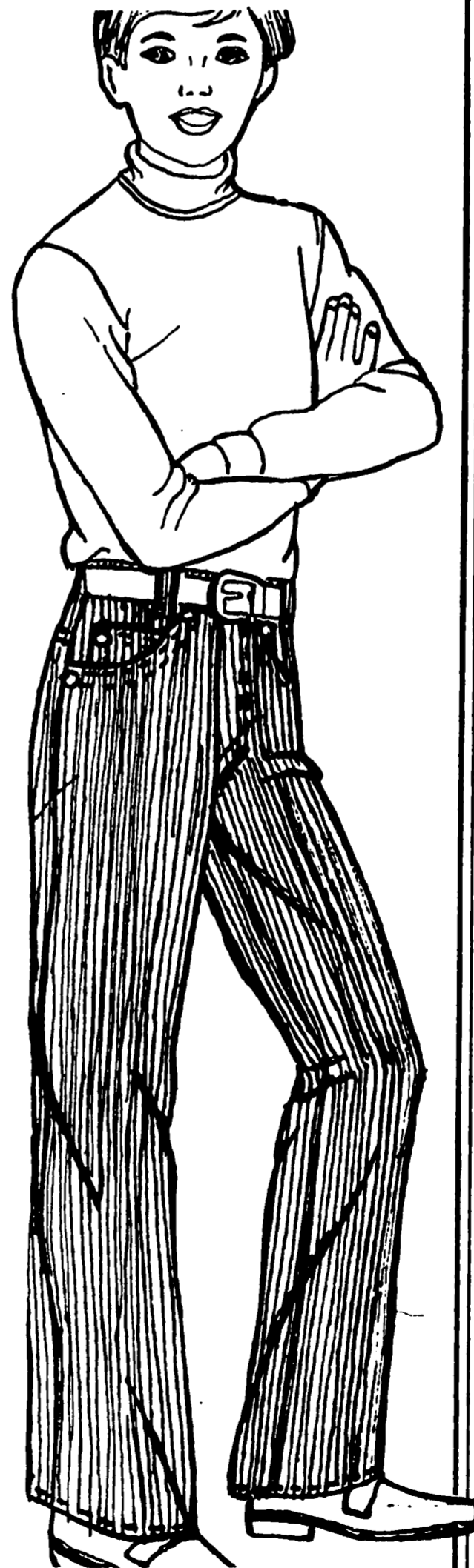
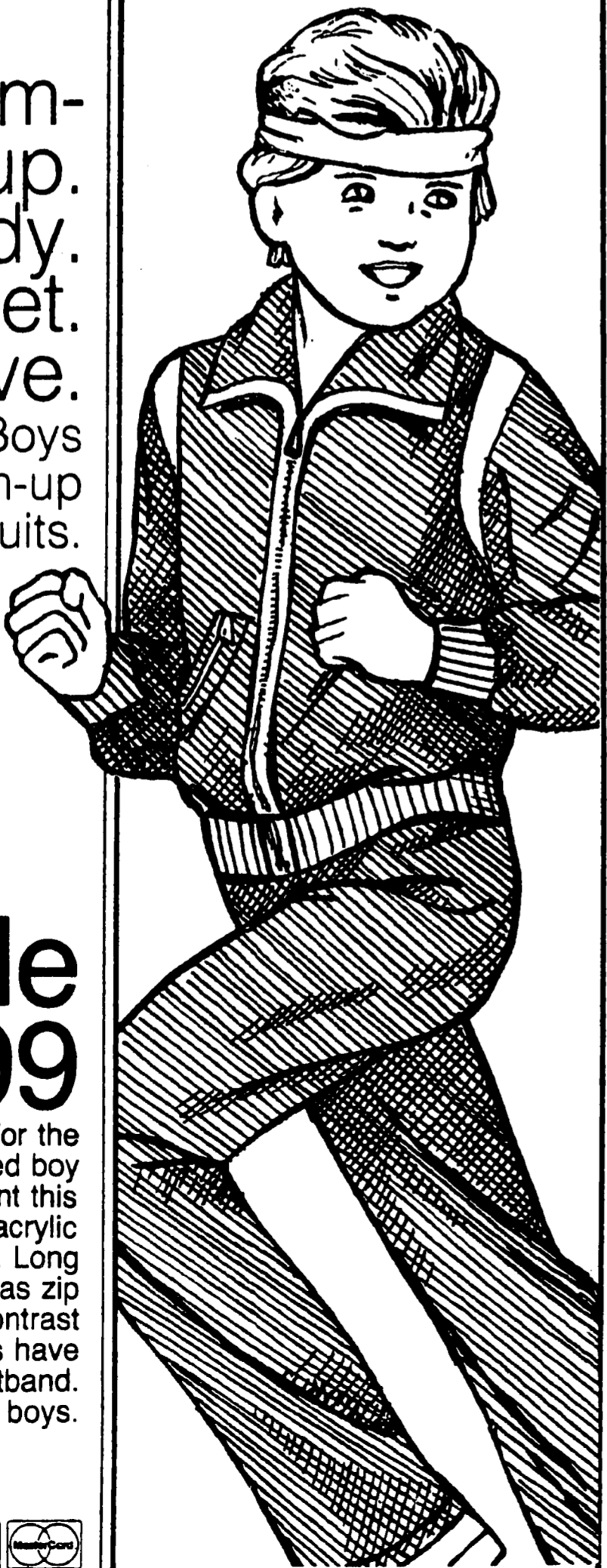

Plain
Pockets[™]
flare
cords.

Sale
7.99

Orig. \$13. Boy's corduroy flares of easy care cotton/polyester. 5 pocket styling. In Prep sizes, great colors too. Only 915 total units.

JCPenney

Save
50%
on the
total
look.

Sale
5.99

Orig. \$12. Boy's knit sport shirt in assorted stripes. Polyester cotton blend. Long sleeves. Pullover styling. Sizes for big boys.

Sale
4.50

Orig. \$9. Boy's polyester cotton dress jeans in great solid colors. Big boys's sizes.

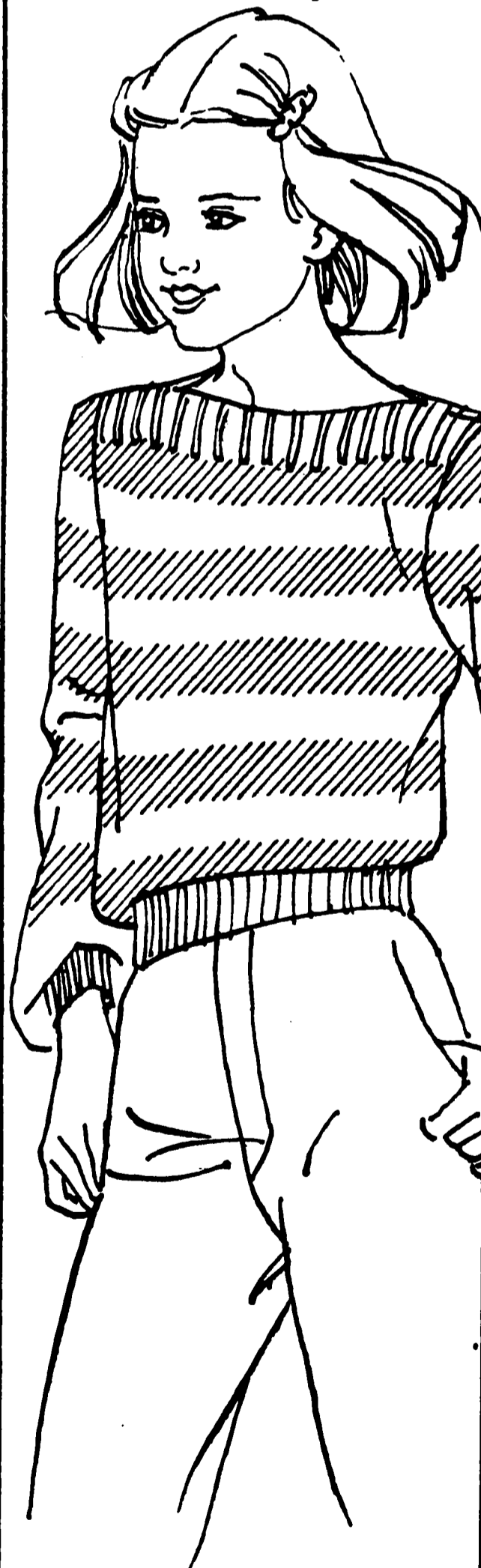
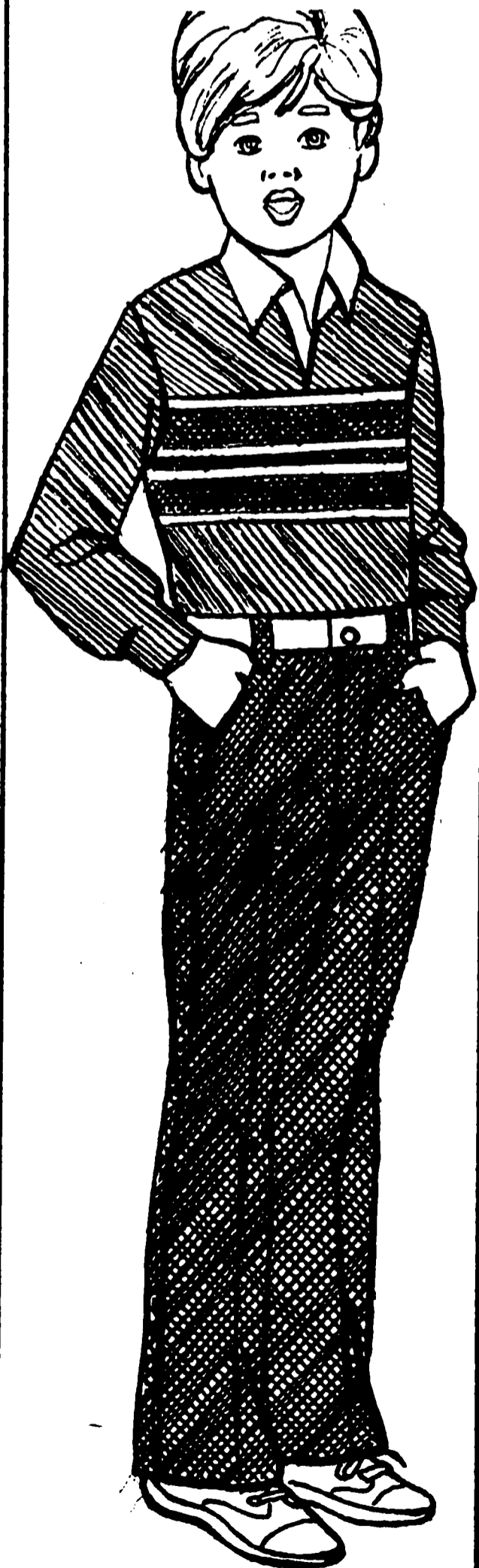

Boat
neck
savings.

Sale
7.99

Orig. \$16. Jr. hi. acrylic/polyester sweaters in wide horizontal stripes. Great colors. Sizes S,M,L for jr. hi girls.

Only 910 total units to sell.



JCPenney

Boys'
basic
jean.
At a very
basic price.

**Sale
4.99**

Orig. \$10. Boys'
sturdy poly/cotton
5 pocket jeans.
Made tough to take
all the action your
boy can give them.
Big boy's sizes.
Only 879
total units.

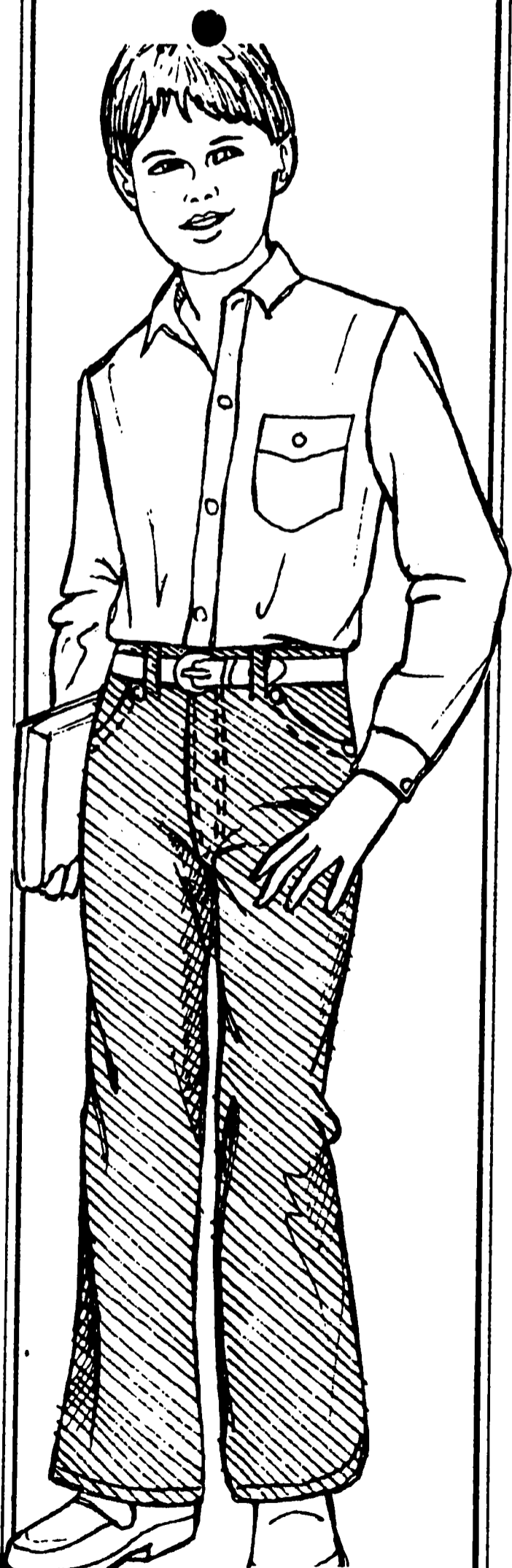

Turn your
bah-
humbugs
into
ho-ho-hos.
Shop-by-
phone with
the
JCPenney
Christmas
Catalog.

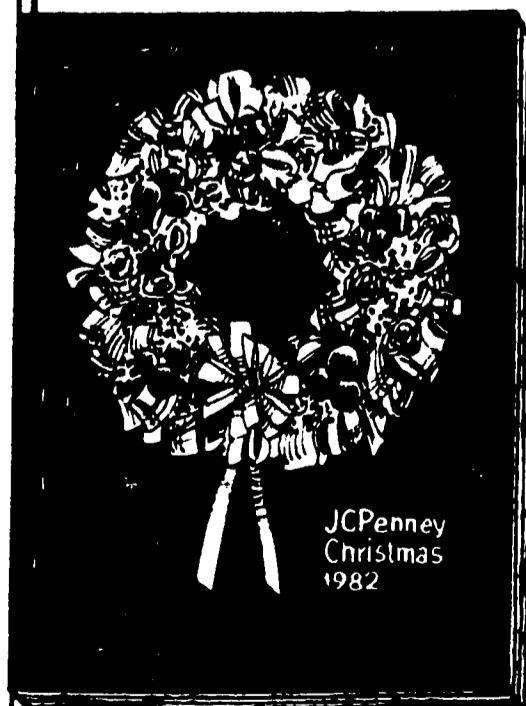

Put joy back into your holiday shopping with the JCPenney Christmas Catalog. No traffic. No lines. No running all over town. It's the book with over 20,000 great gift ideas from family fashions to exciting games and toys that you can order from your own easy chair. By phone. Even get speedy UPS home delivery right to your door. And, best of all, the catalog offers a special selection of beautiful apparel and fine giftware. Just pick up your copy today for only \$1.00 and get a \$1.00 merchandise certificate redeemable on any catalog order you place.
UPS® is a registered trademark of United Parcel Service of America, Inc.

JCPenney

Savings
for little
people.

Sale
5.99

Orig. \$13. Sesame Street® twill coverall of 100% cotton. Front bib pocket. Adjustable straps. Button side closing. Sizes 1-4.

Sale
7.99

Orig. 11.50 to \$13. Sesame Street® Oversleeper of polyester. Ribbed collar and cuffs with stripes. Plastic soles. Front zipper. Sizes 1-6.

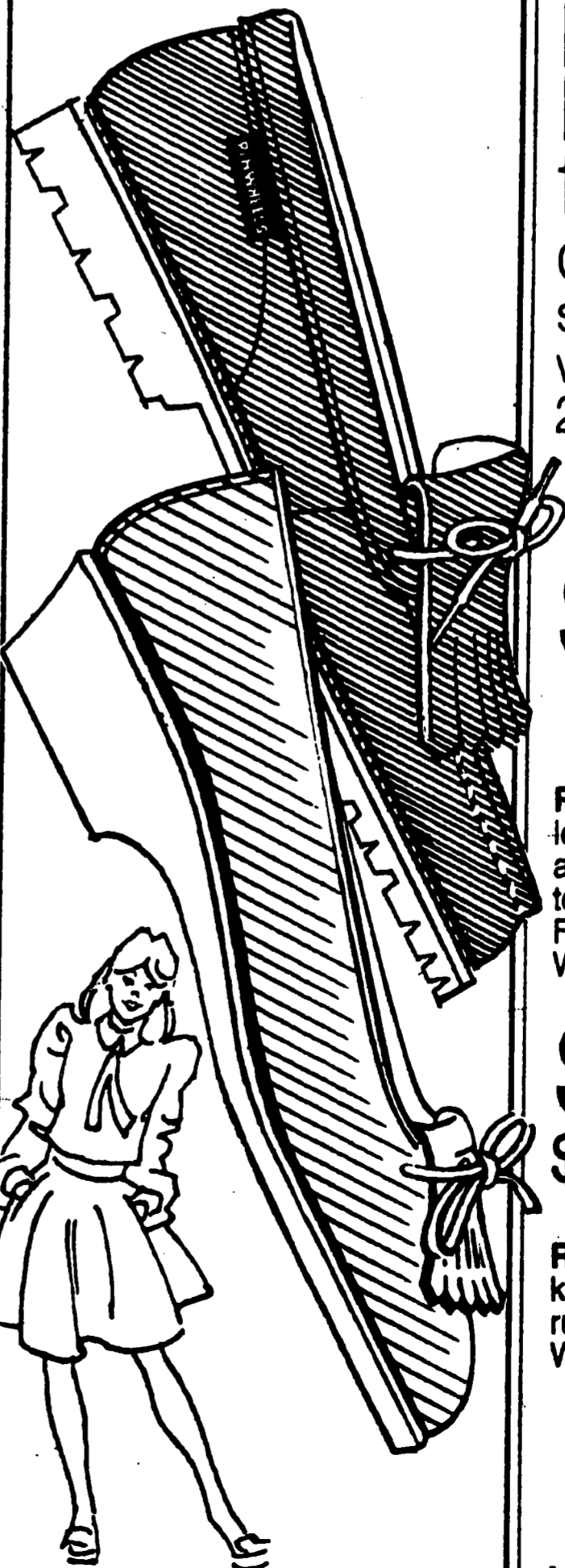

Popular
looks for
fall.

Casual
styles for
women.
25% off.

Sale
19.50

Reg. \$26. Supple leather kiltie slip-on is an attractive addition to your fall wardrobe. Fashion colors. Women's sizes.

Sale
\$24

Reg. \$32. Leather kiltie style slip-on with rubber sole. Tie trim. Women's sizes.

JCPenney

Shetland
sweaters,
tell a
fall story.

Special
16.99

Men's V-neck or crew
neck 100% Shetland
wool sweaters.
Completely machine
washable. Decorative
cable stitching. Sizes
S,M,L,XL.

Only 936 units.

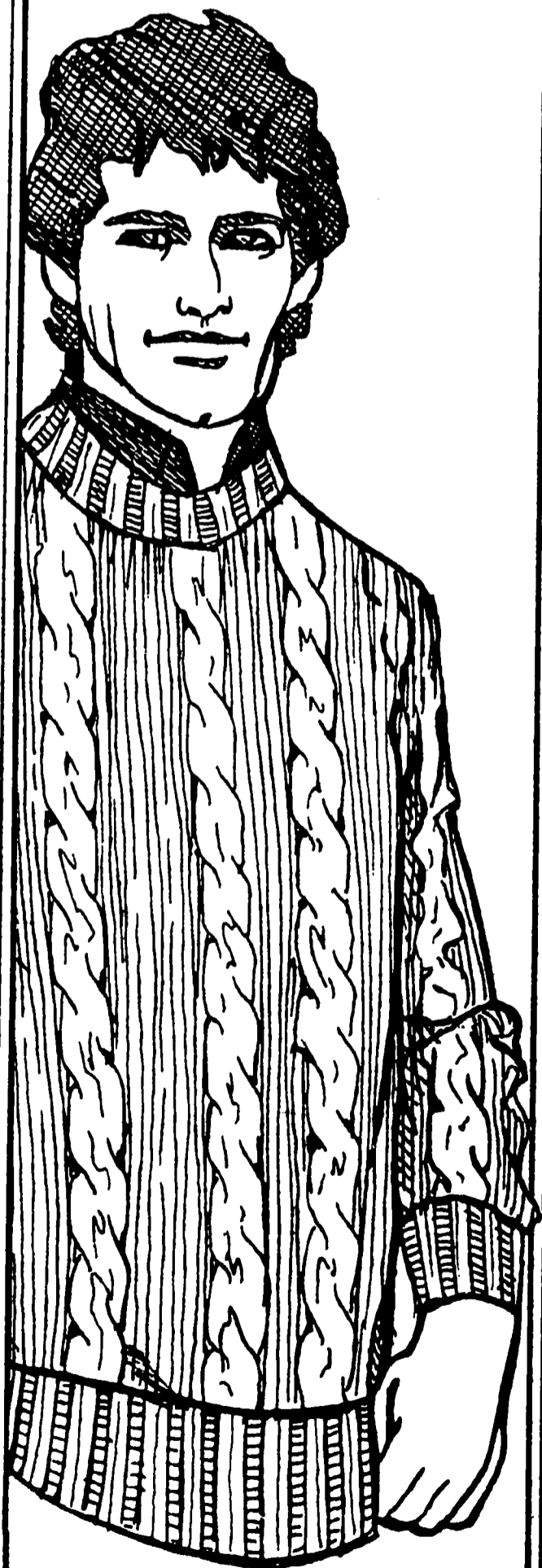

Zip
it up.
Duo-jacs for
men.

Special
39.99 to
44.99

From a jacket to a
vest in one quick zip.
100% nylon ski
jackets, some with
corduroy trim. Roomy
pockets. Zip front.
Sizes S,M,L,XL.

JCPenney

Cozy savings on men's chenille sweaters.



Sale
14.99

Orig. \$18 to \$20.
Men's handsome chenille sweaters in V-neck or crewneck styles. Your choice of solids or horizontal stripes in 100% acrylic. Sizes S, M, L, XL.
Only 2,000 units to self.

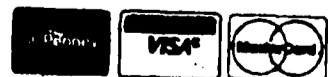

Suddenly, learning is different.
Texas Instruments Home Computer.



Only \$199 With rebate

Reg. \$299
— \$100 Texas Instruments Rebate

\$199 Your final cost.

You don't have to be an expert to use our Home Computer. You can manage your household and personal finances. Helps students sharpen spelling, math, reading and grammar skills. A challenging partner for a game of football, chess and any one of TI's new game releases. It not only plays with you, but the Home Computer can teach you a game from the first strategic move to the winning move.

Buy any 6 command cartridges and you get a Speech Synthesizer at no extra cost from Texas Instruments. A 149.95 value!

One of the most popular options, the Solid State SpeechSM Synthesizer reproduces the human voice electronically. By adding verbal prompts and special messages to the user, the Speech Synthesizer adds a new dimension to learning. It talks to you.

JCPenney

Warm
flannel
for men.

**Special
6.99**

Men's western style
cotton flannel shirts in
bold plaids. Snap
closings. Two front
pockets with flaps.
Sizes S, M, L, XL.
Tall sizes **Special 7.99**
Only 1400 units
to sell.

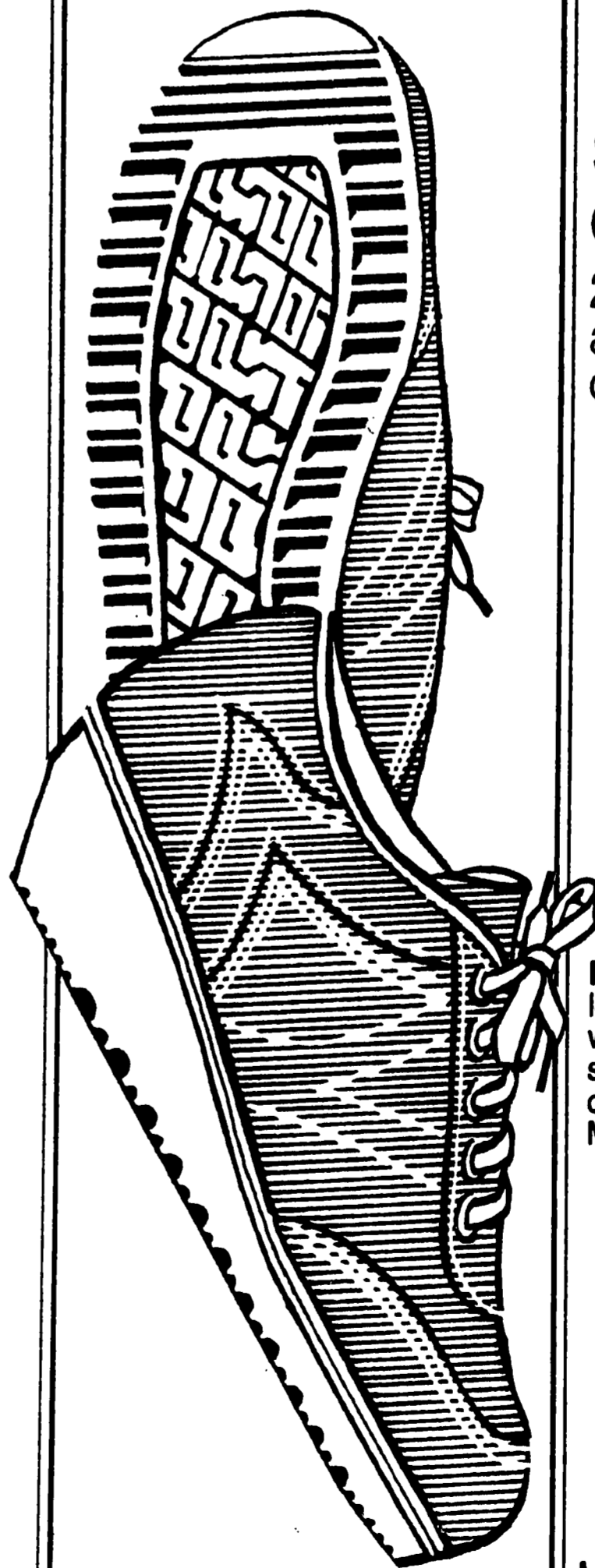
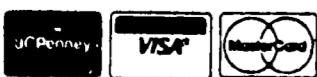
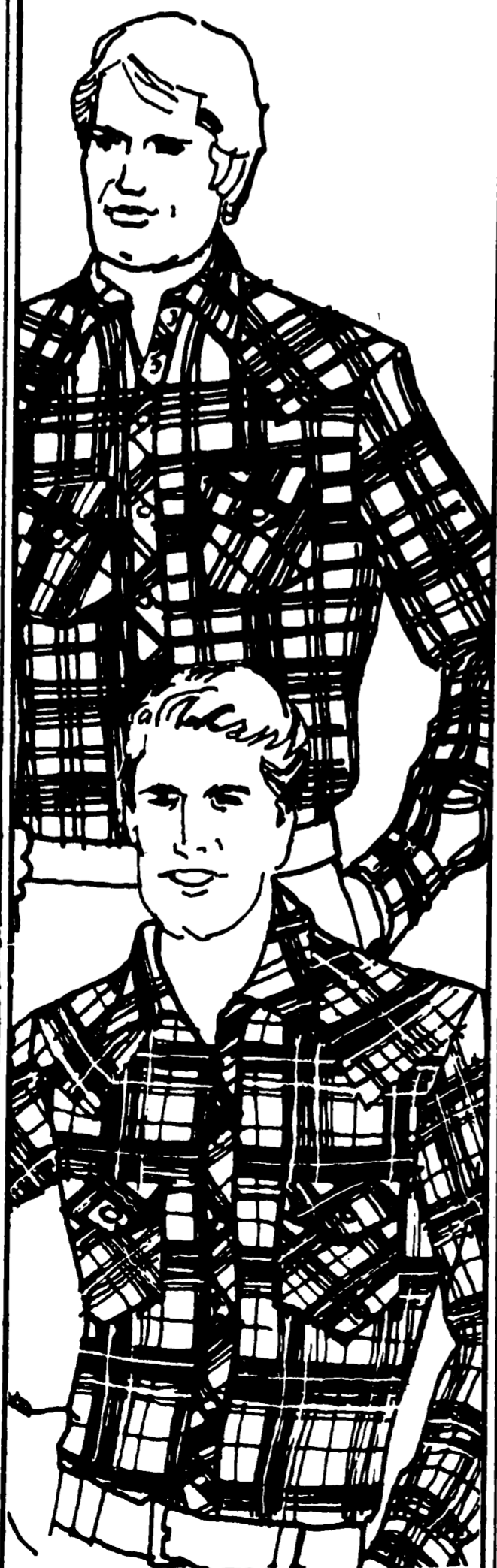

Men's
suede
oxfords.

25% off
all men's
casual shoes.

**Sale
\$18**

Reg. \$24. Rich
looking suede oxfords
with decorative
stitching. Padded
collar. Fall colors.
Men's sizes.

JCPenney

25% off
 already marked
 down items in
 our fine jewelry
 department.

- Gold filled jewelry
- Diamonds
- Watches
- Stone rings
- and more.

Look for the
 red tags.

Sample
 Orig. \$100
 Now \$85
 Additional
 25% off 21.25
 You pay 63.75

Regular price
 merchandise not
 included in this sale.
 Only merchandise that
 has a red and white sales
 tag is included.
 JCPenney Mall stores only.

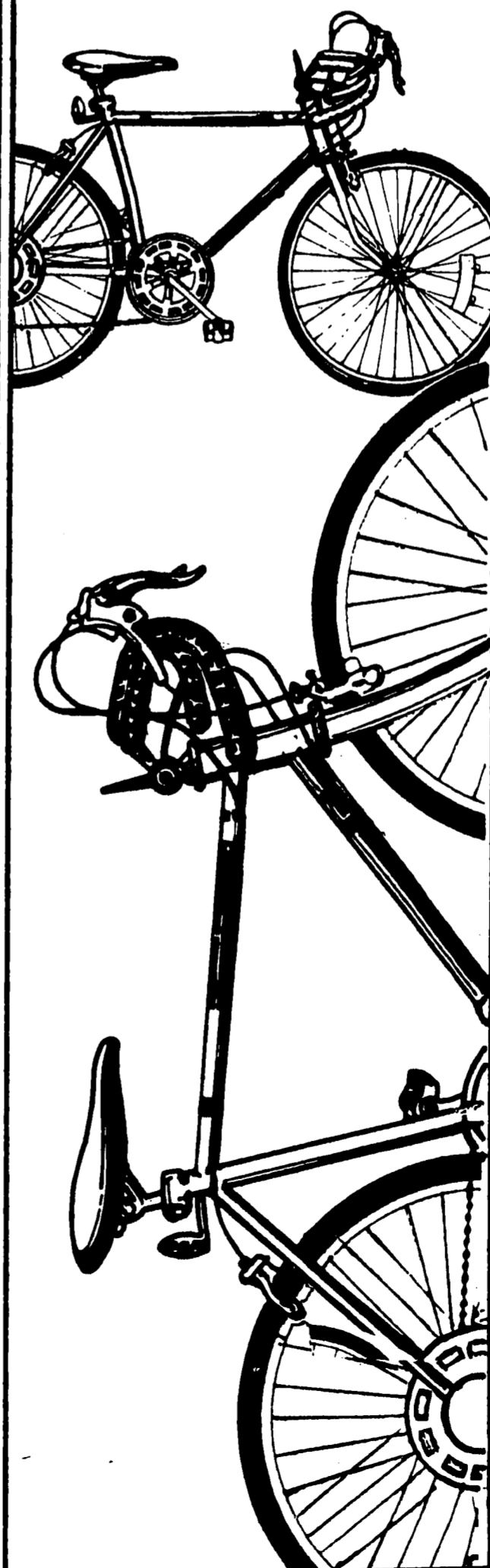
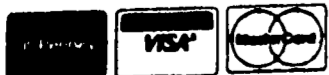

Save \$30
 on men's
 10-speed
 bike.

Sale
79.99

Orig. 109.99.
 10-speed 26" racing
 style bike features
 dual caliper brakes
 with extension levers.
 This bike is not
 included in the 15%
 off sale on all toys
 and bikes. Bikes
 come unassembled.

JCPenney

It pays to shop
for Christmas
before Thanksgiving.
All toys, bikes and
hobby gear.

15%
off

Christmas is right around the corner. And, so are savings when you shop now at JCPenney. Because we're taking 15% off great gift ideas that the kids will love. Start with our endless assortment of toys and games. Dolls they can snuggle up to. Action figures they can conquer the world with. Educational toys they can learn from. All the famous names are here, along with the kids' favorite friends from TV and movies. Plus a complete line of bicycles for boys and girls on the go. Two-wheelers, three-wheelers, racers and more. No matter what, JCPenney has something for every kid. And savings for you. Bicycles come unassembled. Men's 10 speed bike on page 35 is not included in this sale.

A small deposit will hold your toys in
Layaway until Dec. 15th.
Sale prices effective through Saturday Oct. 23rd.

Available at JCPenney Northland,
Eastland, Fairlane Town Center, Lakeside,
Westland, Southland, Twelve Oaks Mall and Oakland Mall.
Also available at JCPenney Briarwood in Ann Arbor.

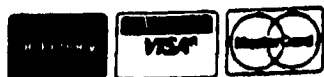

File
away the
savings.

Sale
39.99

Orig. 59.99. For home or office use, you'll want this ready to assemble filing cabinet. Walnut look finish. Two drawers on easy gliding rollers. 15" x 15³/₄" x 26¹/₂" high.

Limited quantities.

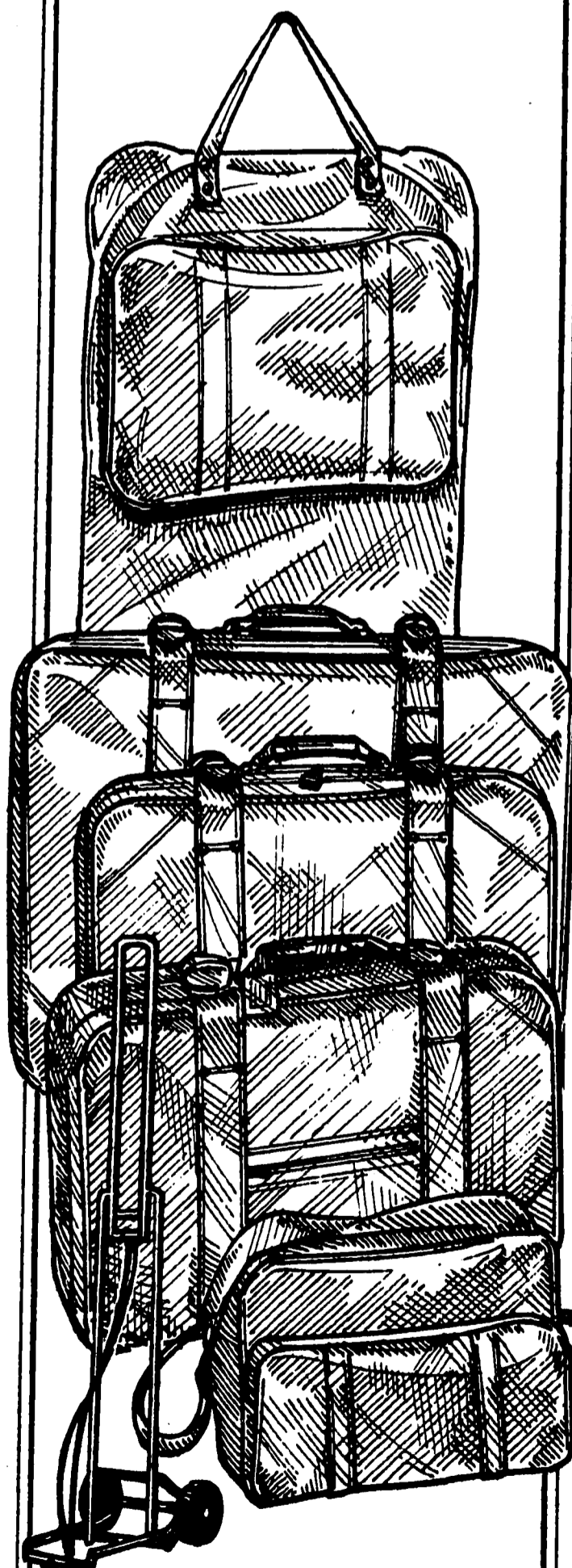
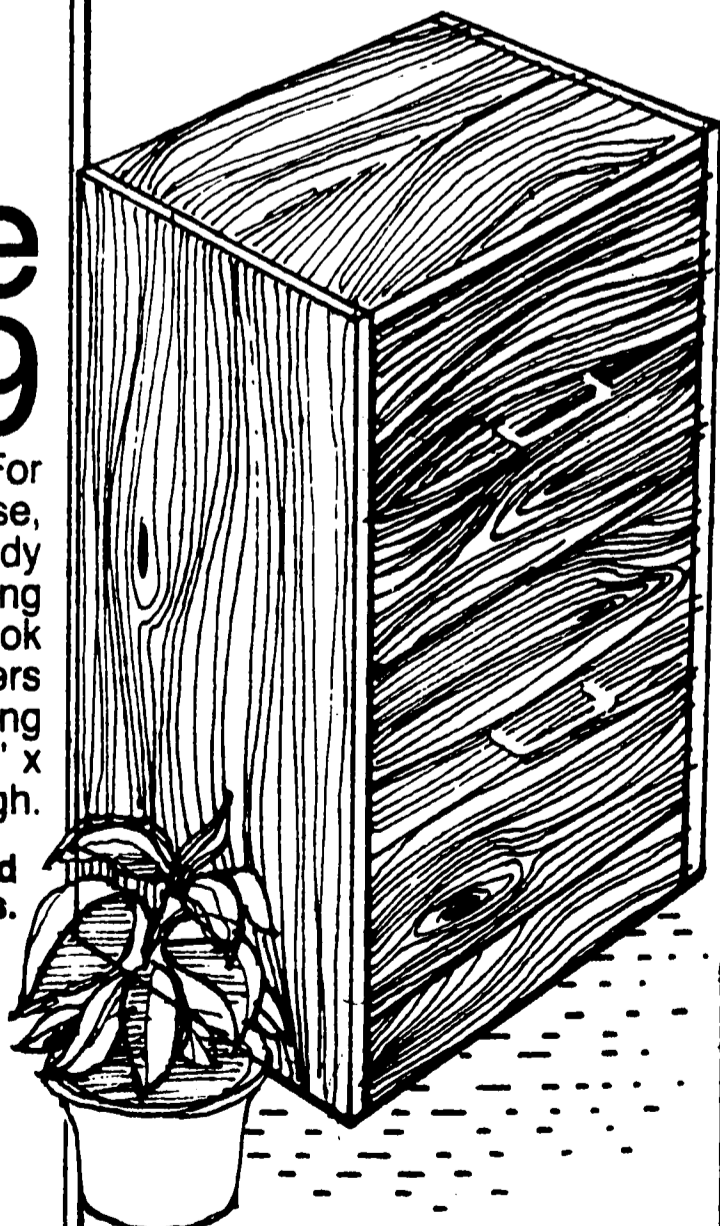
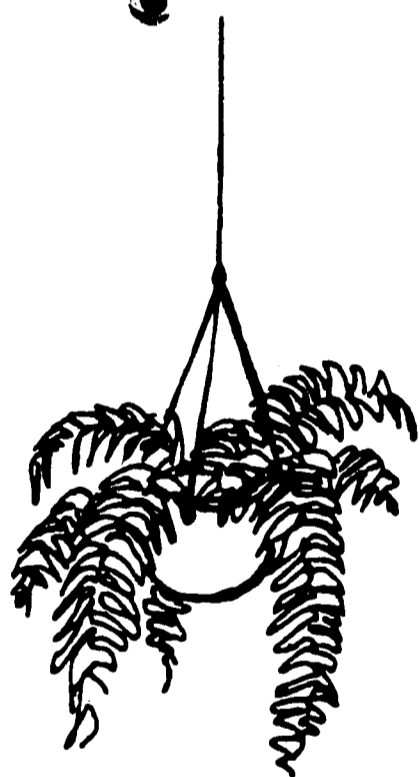

Easy
getaway.

30% off Series
500 luggage.

Sale
76.97

Reg. 109.95. Save on this 5-piece steel reinforced softside luggage set with sturdy buckles. Bags nest for easy storage. Wheels on pullman and jumbo pullman.

	Reg.	Sale
27" Jumbo pullman	32.99	23.09
25" pullman	26.99	18.89
22" underseat carry-on	21.99	15.39
42" unisex garment bag	16.99	11.89
15" tote with strap	10.99	7.69
Tubular steel luggage rack	\$15	10.05

JCPenney

Cart
away the
savings.

Your choice of
TV or video
game cart.

Sale
29.99

Orig. 44.99. Video
games cart has
walnut-look finish
with brass shielded
casters. Slanted shelf
for easy access and
half-shelf for
additional storage of
accessories and
cartridges.

Sale
24.99

Orig. 37.99. TV cart in
Formalon® Waverly
walnut. Accommodates
all portable
televisions. Easy-roll
casters with tilt shelf
for magazines. Ready
to assemble.
TV not included.

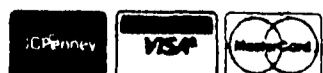
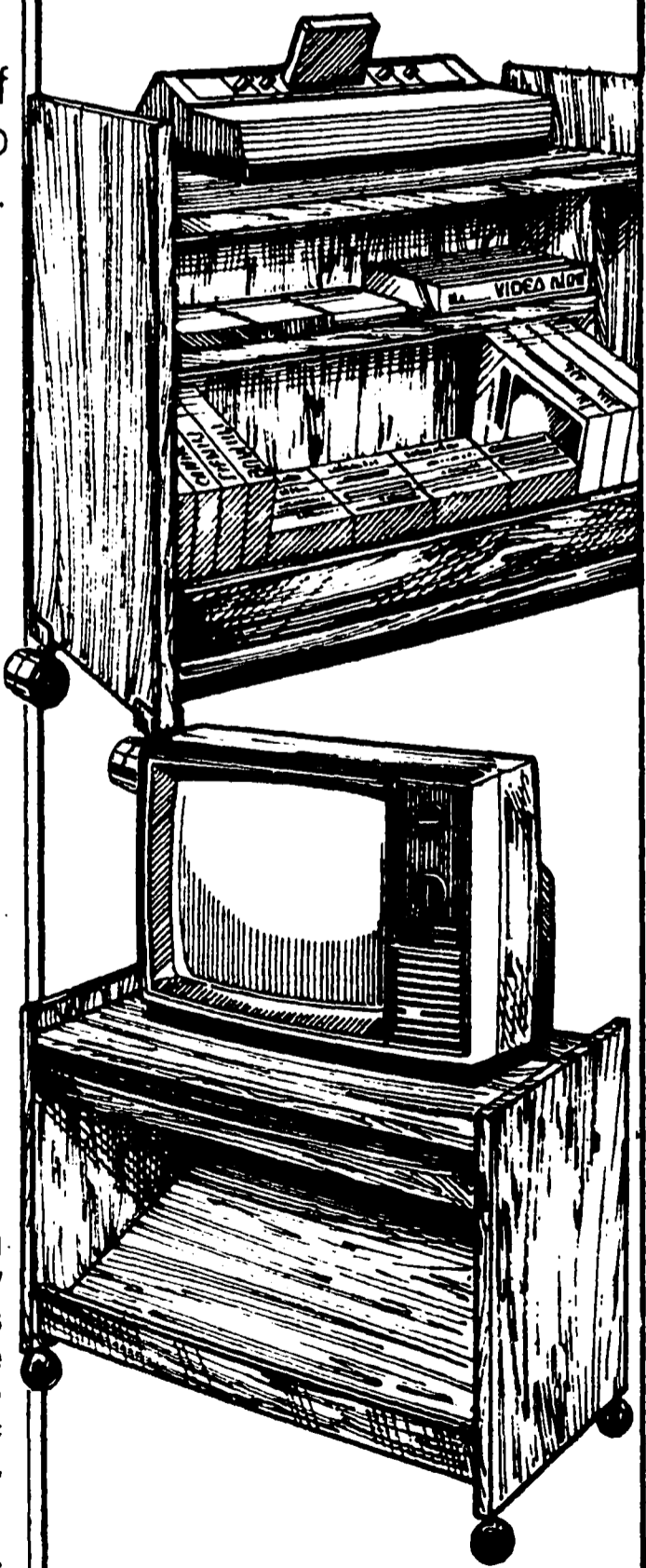

Sale
79.99

Orig. 119.99. Formalon®
Waverly walnut finish wall unit.
One door featuring frame and
cane panel. Add a whole new
look to any room and extra
shelf space, too. Ready
to assemble.

Wall
to wall
savings.
Redefine your
living space.

JCPenney

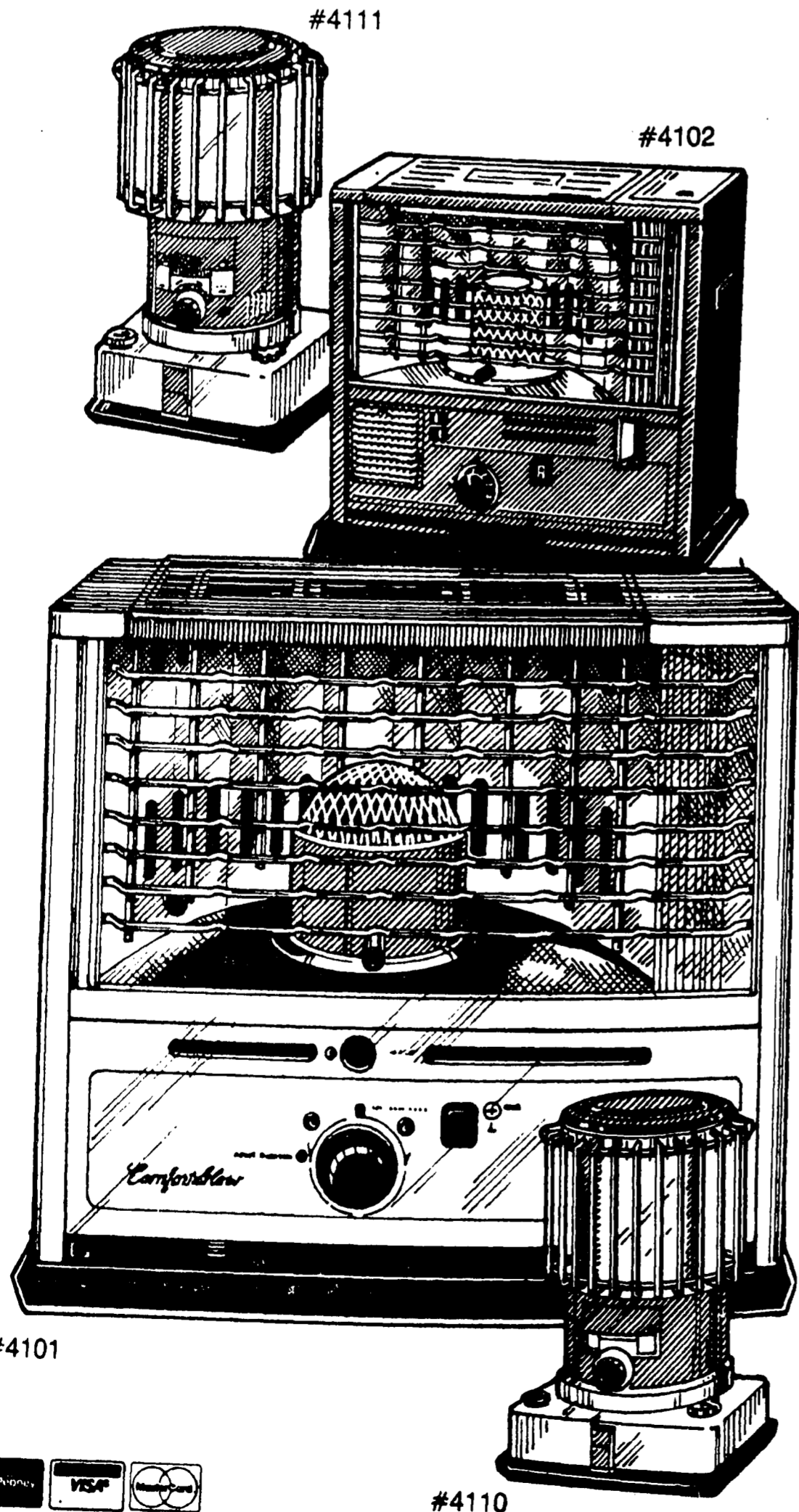

Pre-Season sale
25% off
 Kerosene heaters.

Sale 224.99

Reg. 299.99. Comfort Glow™ 19,500 kerosene convection heater has a powerful output. Features self-cleaning wick, push button ignition. Has convenient carrying handle. Operates 13 hours on one kerosene filling. #4111

Sale 209.99

Reg. 279.99. Comfort Glow™ 9,300 BTU kerosene reflection heater has a built-in fan for improved heat distribution. Features removable fuel tank, self-cleaning wick, lightweight design, pushbutton electric ignition. 16 hours operation. #4102

Sale 149.99

Reg. 199.99. Comfort Glow™ 9,000 BTU kerosene reflection heater supplies radiant heat from the front and the top of the unit. Has self-cleaning wick, pushbutton electric ignition. Operates up to 16 hours on one filling. #4101

Sale 172.49

Reg. 229.99. Comfort Glow™ 12,500 BTU kerosene convection heater distributes heat in all directions. Great for large areas. Pushbutton ignition. Has carrying handle. Operates continuously for 17 hours on one filling. #4110

JCPenney Mall stores only.

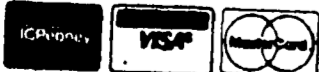

#4110

4 for \$24
Wheel
balance.

Dynamic and static
balance each wheel
to help assure
smooth ride.

Sale
2 for \$74

Reg. \$43 ea., plus
fed. tax,* size
P165/80D13 WW.
Our El Tigre II has 6
bias ply and 6 bias
belted sizes.
Polyester cord body.

Size/Blackwall	Reg.	Sale*
P165/80D13	\$38	\$32
P185/80D13	\$44	\$37
P195/75D14	\$49	\$42

*Plus fed. tax from 1.55
to 2.65 each tire.

Size/Whitewall	Reg.	Sale*
P165/80D13	\$43	\$37
P185/80D13	\$49	\$42
P195/75D14	\$53	\$45
P205/75B14	\$61	\$52
P215/75B14	\$66	\$56
P225/75B14	\$72	\$61
P215/75B15	\$71	\$60
P225/75B15	\$74	\$63
P235/75B15	\$79	\$67

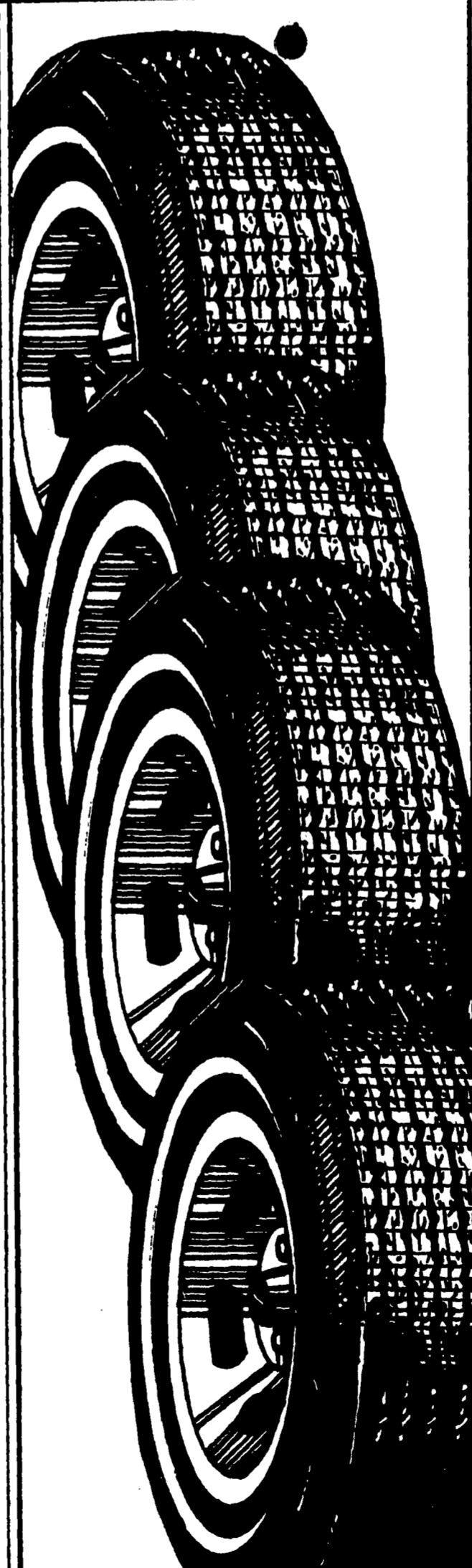
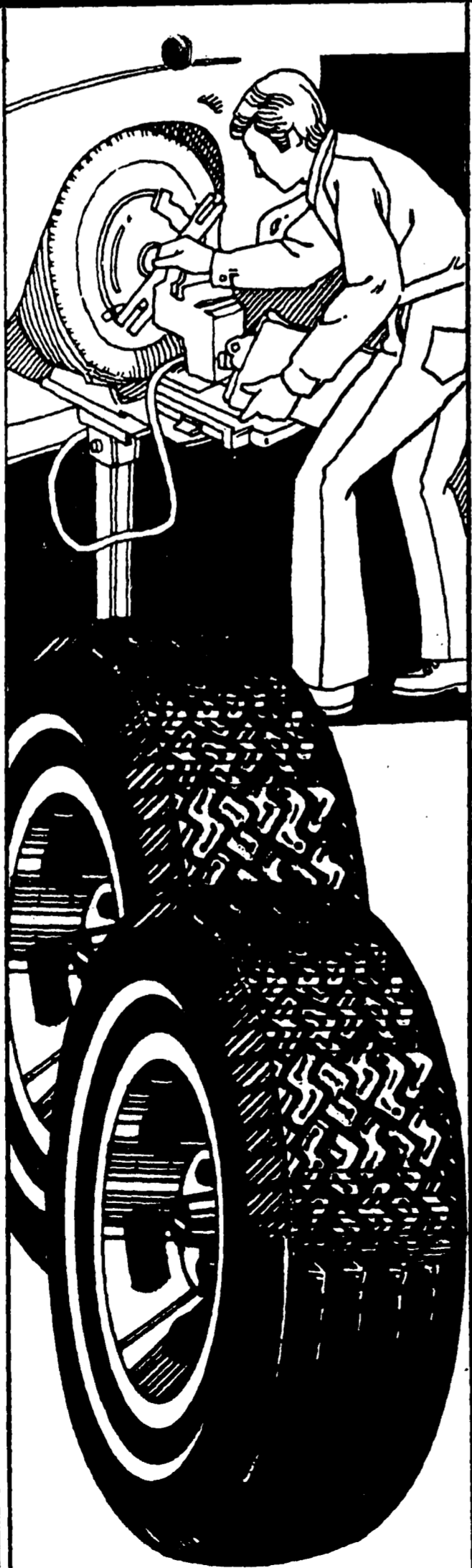

Save
\$32 to
\$68 set of 4
Mileagemaker®
Plus
steel belted
radials.

Reg. \$56 ea.,
Sale \$48., plus fed.
tax*, size
P155/80R13 WW.
The Mileagemaker®
Plus steel belted
radial has a polyester
cord body with
2 steel belts.

Size/Whitewall	Reg.	Sale*
P155/80R13	\$56	\$48
P165/80R13	\$68	\$57
P175/80R13	\$73	\$62
P185/80R13	\$75	\$63
P185/75R14	\$81	\$69
P195/75R14	\$84	\$71
P205/75R14	\$93	\$79
P215/75R14	\$98	\$83
P205/75R15	\$95	\$80
P215/75R15	\$100	\$85
P225/75R15	\$105	\$89
P235/75R15	\$111	\$94

*Plus fed. tax from 1.53
to 3.01 each tire.
Tires mounted at no
extra charge.
No trade-in required.
Mag wheels extra.
Sale ends Saturday.

JCPenney

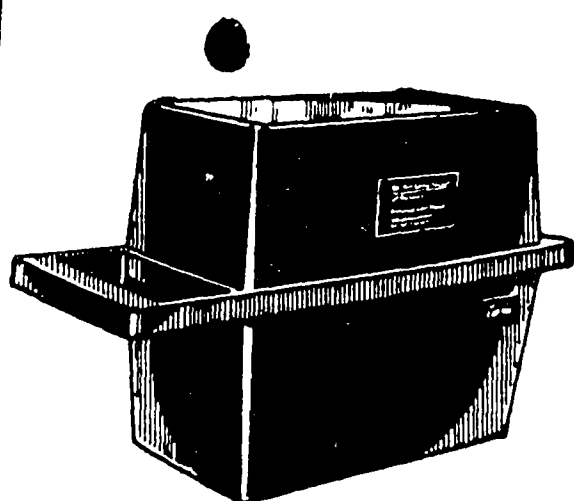

Sale 25.99

Reg. 32.99. 12 volt air compressor plugs into cigarette lighter, has 160 PSI capacity. Includes dial pressure gauge, 10' cord and carry case.

Save \$15 pr.

Sale 44.99

Reg. 59.99. 3-way 6 1/4" door mount speaker kit has 2 speakers, wire, all mounting hardware, instructions.

Sale 54.99

Reg. 69.99. 3-way 6"x9" deck-mount speakers team up a woofer, tweeter, plus a midrange to faithfully reproduce the highest highs and lowest lows.

Sale 18.99

Reg. 24.99. Keep seats, rugs and trunk clean in car, camper or boat. 12 volt auto vac plugs into cigarette lighter, includes accessories and built-in light.

Save \$50

Sale 149.99

Reg. 199.99. In-dash AM/FM car stereo has Power-Up® to boost output 15 watts per channel. Power-Up® stereo with cassette, graphic equalizer, Reg. 179.99, Sale 129.99

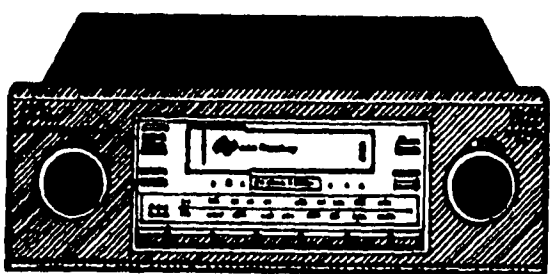

JCPenney Auto Centers.

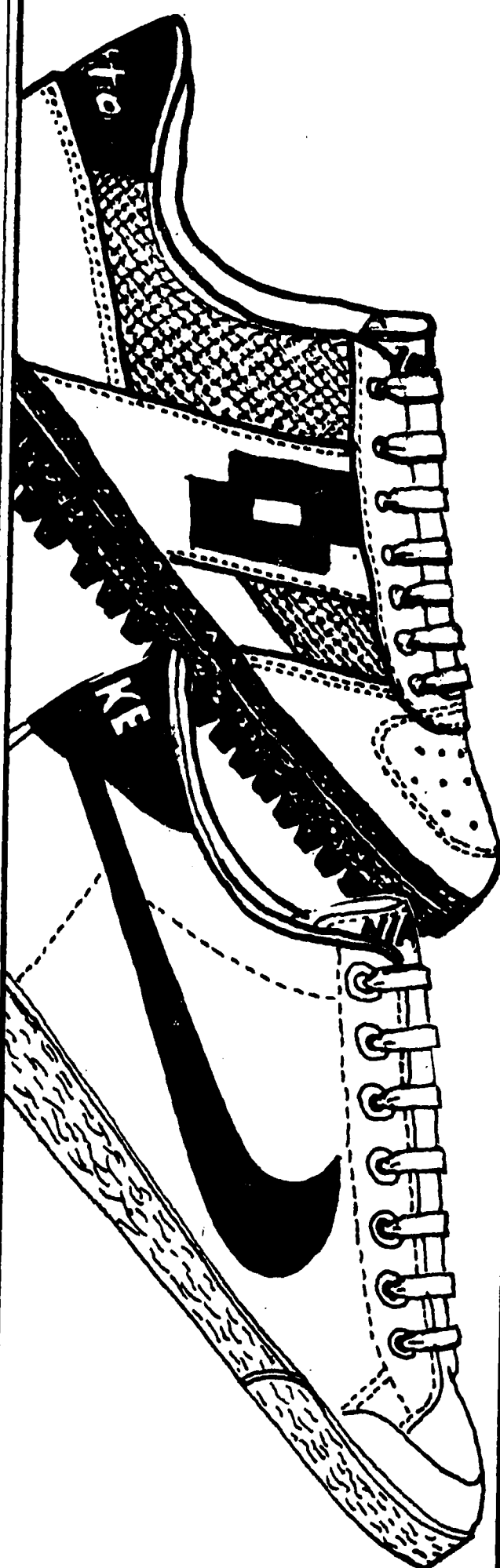

Savings for the sports-minded.

Sale 14.99

Orig. 19.99. Lotta® training shoes with sturdy construction. Rubber soles with gripping action. Black and white in men's sizes.

Sale 16.99

Orig. 19.99. Nike® "Court Master" canvas low cut basketball shoe. Rubber toe guard. Padded collar. White/black in men's sizes. A total of 1,200 total units. JCPenney Mall stores only.

JCPenney

Warm savings for girls. Popular stadium look.

Sale 29.99

Orig. \$40-\$45. Girls stadium coats in your choice of polyester / cotton quilted poplin or wide wale cotton corduroy. Both have removable hood, stand up collar and knit cuffs. Great colors in sizes 7-14. Only 936 total units to sell.



Boy's jacket buy.

Special 34.99

Boy's jackets in several styles. Many with zip-off sleeves that convert to a vest. Others are reversible. All are easy care fabrics including nylon, chintz, poplin, some with corduroy insets. Sizes for big boys.

Only 937 total units to sell.



JCPenney

Jordache®
jeans
for men.

The designer
look for him
at a very
easy price.

Sale
29.99

Orig. 39.99.
Jordache® designer
jeans designed to fit
with all the special
details you'd expect.
Made of 100% cotton
with fancy stitching.
Straight legs. Back
pocket label.
Sizes for men.

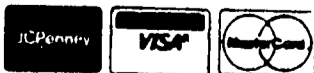
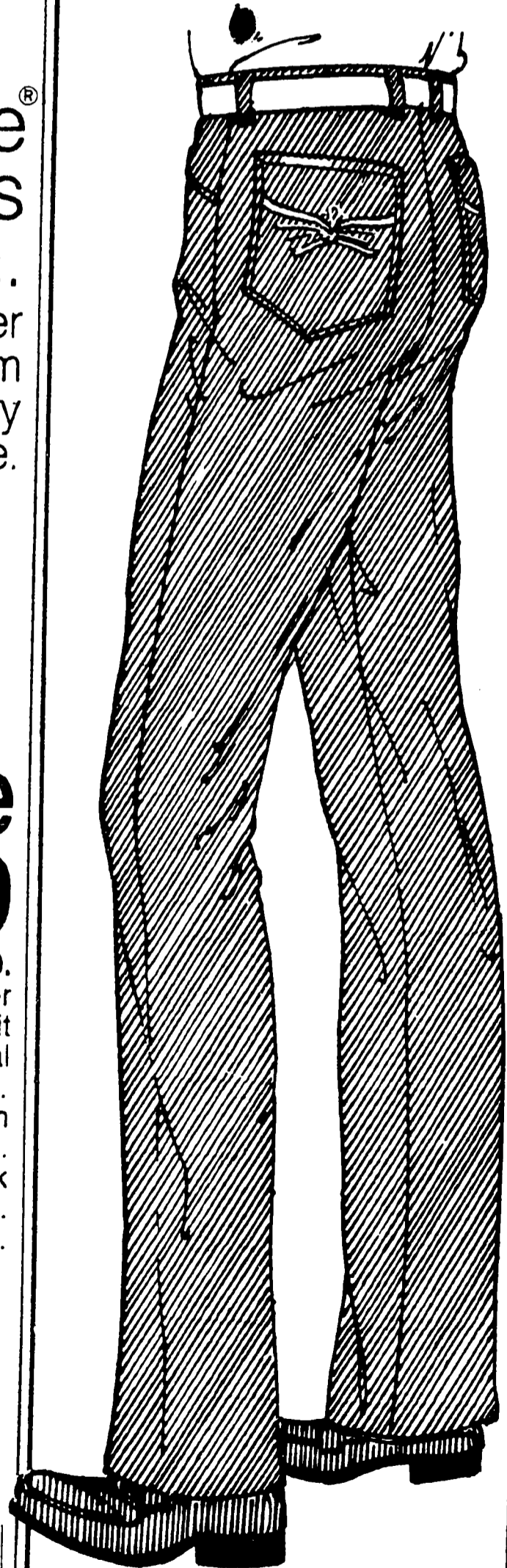

Gentry.™
For the man
who wants a
trimmer fit.

Sale
129.99

Reg. \$175. Gentry.™
A slimmer silhouette
tailored in poly/wool
with the attention to
detail you demand.
Traditional solids or
stripes.
Gentry.™ solid dress
shirt.
Reg. \$15 Sale 11.99
All silk tie.
Reg. 13.50 Sale 9.99

JCPenney
Fall Sale Break

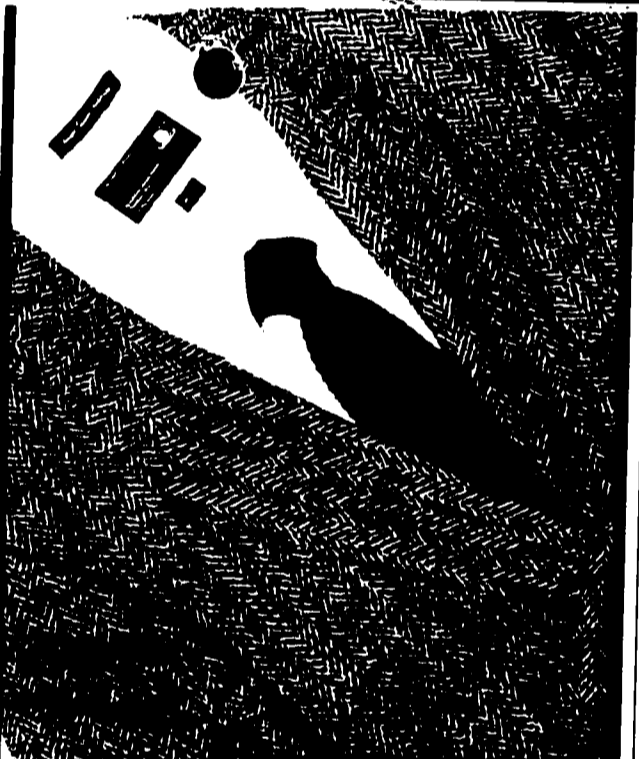

Save
 \$20 to
 \$29
 Stafford™
 wool
 sportcoats.

Sale
 89.99

Reg. \$119. When it's pure wool, you never have to question the quality. Like our Harris Tweed sportcoat with expert styling.

Country wool sportcoat. Reg. \$90, Sale 69.99

Worsted wool flannel slacks. Reg. \$45, Sale 34.99

Stafford™ collection oxford button down dress shirt. Reg. \$18, Sale 13.99

Solid color knit tie. Reg. 8.50, Sale 6.99

JCPenney