

For smokers who prefer the convenience of five more cigarettes per pack.

New Marlboro 25's

Now, famous Marlboro Red and Marlboro Lights are also available in a convenient new 25's pack.



Warning: The Surgeon General Has Determined That Cigarette Smoking Is Dangerous to Your Health.

Lights 11 mg "tar," 0.7 mg nicotine. Kings 17 mg "tar," 1.1 mg nicotine av. per cigarette, by FTC method.

Not available in some areas. © Philip Morris Inc. 1985

30¢
WEDNESDAY
January 30, 1985

Volume 29
Number 40
Three Sections
28 Pages plus Supplements

the NOVI NEWS

also serving Wixom and Walled Lake

Living PERSONALITY T
REVEAL INNERMOST TRAITS

Sports FREE THROWS I
HOWELL PAST NOVI CAGER

Opinions CALANDRO'
HELPED GAIN TRAFFIC LIGHT

NOVI NEWS
44300
1100
92266 TM

Next step in Town Center plans approve

By KATHY JENNINGS
staff writer

NOVI — Consultants planning the commercial area at Grand River and Novi Road have received authority to proceed to the next step in the planning process — drafting an agreement outlining aspects of the development to be negotiated.

Although city officials previously

have criticized aspects of the plan originally proposed by consultant's Zucchi, Hunter and Associates (ZHA), there were few negative remarks about revised plans presented to a joint meeting of the planning board and city council Thursday.

Some indicated their concerns were addressed by changes in the plan, while others said the proposal

still does not represent what the city originally intended. But overall reaction to the proposal appeared positive, if not enthusiastic.

The consultants also advised city officials they must soon become "actively involved" in the project.

"The developer is going to need assistance from the city financial or otherwise," Consultant Thomas Yockey said. "The city will need to

form a redevelopment district, establish a Tax Increment Finance Authority, acquire land or set a master plan for development."

Consultant Michael Dzaman encouraged the city to acquire the property through eminent domain. "You have to do something unless you can find Father Novi who is going to come in and build a statue you can plan your town center around."

The city must take a "high posture" in the process, either by acquiring the property or by establishing a redevelopment authority, Dzaman said. "You have to institute a planning process."

The Town Center will be off to a "better start" if the city acquires the property, Dzaman said.

Yockey cautioned against taking an "extreme approach" — assembling

property — at this point. He told city officials there are other steps that can be taken which could work as well, without actually purchasing property in the Town Center.

He also indicated the city could purchase the property and go through a planning process, only to end up with the same type of develop-

Continued on 4



Students at Novi Middle School South celebrate their 'outstanding' ranking

Novi News/STEVE FECHT

Middle School gets 'outstanding' rating

NOVI — When it comes to ranking secondary schools, Novi Middle School South can consider itself among the best.

At least that's the word that came down from the State Board of Education last Thursday.

Novi Middle School South was one of 19 Michigan schools nominated for consideration in a national program to recognize outstanding secondary schools.

The 19 schools — including five from Oakland County — were selected from among 91 middle,

junior and senior high schools throughout the state that were nominated to represent Michigan in the third year of the national Secondary School Recognition Program.

The nomination — a first for the Novi Community School District — was met with considerable enthusiasm by Novi Middle School South Principal Charles Nanas.

"Needless to say, we're pretty excited," Nanas said. "It's like a North Central Evaluation."

Nanas explained that each school in the state is sent an application for nomination. The 17-page application

includes 14-15 different criteria areas.

Nanas noted that this is the first year Middle School South has applied for nomination and credits the staff with helping put together the application.

Norman Otto Stockmeyer, Sr. of Westland, president of the State Board of Education, said the 19 schools being nominated for national honors "are representative of the many outstanding schools among Michigan's nearly 1,200 secondary schools."

State Superintendent of Public In-

struction Phillip E. Runkel said U.S. Secretary of Education William J. Bennett will announce the names of schools that are chosen as finalists in April.

All finalists will be visited by representatives from Bennett's office, and the announcement of schools receiving national awards will be made in June.

Last year, Michigan nominated 18 schools and 14 were named national finalists. Eleven of the 14 schools received national honors.

Schools that receive national awards are ineligible to enter the

competition again.

Other Oakland County schools nominated for the program were Seaholm High School in Birmingham, Berkshire Middle School in Birmingham, Abbott Middle School in West Bloomfield and Levey Middle School in Southfield.

Runkel said the State Board of Education will honor the 19 schools nominated for the program at a special honors ceremony in March. Special certificates will be awarded to the other 72 schools that were nominated in the Michigan recognition program.

Natalzel said the outstanding tax bill on Empire of America accounts exceeds \$400,000 in Novi. In Northville Township, Harral estimated that

Continued on 4

County to install traffic light at Ten Mile/Taft intersection

NOVI — Thanks to an assist from Oakland County Commissioner John Calandro, Novi residents most likely will see a traffic signal installed at the Ten Mile/Taft Road intersection sometime before the spring thaw.

Calandro told Novi Board of Education members at their last meeting that a four-way regular working signal will replace the current flashing light at the intersection.

However, Calandro said the commission "did not get the same counts in the summer as they would in the fall."

With the urging of his Turtle Creek neighbors, library personnel, the school board and others, Calandro requested that the commission reconsider its decision.

"The real concern was the schools," Calandro said, noting that the road commission agreed to the signalization after reconsideration of its traffic count study.

The commissioner pointed out that the final decision was made by managing director John Grubba who said every effort would be made to install the light by March.

In late November, the school board and city council again pushed for signalization, arguing that the traffic count used by the county to determine whether a light would be installed was taken during the summer when there was no school traffic.

Calandro said he was approached early last summer about the Ten Mile/Taft Road signal and noted that the road commission came out to study the intersection at his request.

However, Calandro said the commission "did not get the same counts in the summer as they would in the fall."

With the urging of his Turtle Creek neighbors, library personnel, the school board and others, Calandro requested that the commission reconsider its decision.

"The real concern was the schools," Calandro said, noting that the road commission agreed to the signalization after reconsideration of its traffic count study.

The commissioner pointed out that the final decision was made by managing director John Grubba who said every effort would be made to install the light by March.

"Fantastic," said Mrs. 'H' of Howell, who received at least 60 calls on a house-for-rent ad she placed in the Green Sheet. She rented the house in the first week...

GREEN SHEET

Action Ads
Get Results
888-2121
348-3624

inside

BIRTHS	3C
BUSINESS CLASSIFIEDS	1B
EDITORIALS	6A
ENGAGEMENTS	2C
KATHY JENNINGS	6A
LIVING	1C
MICHELE FECHT	7A
NOVI HIGHLIGHTS	2C
OBITUARIES	5A
PHIL JEROME	6A
POLICE BLOTTER	5A
REC BRIEFS	5C
SPORTS	4C
WEDDINGS	2C

EDITORIAL 349-1700
ADVERTISING 349-1700
CLASSIFIEDS 348-3624
HOME DELIVERY 349-3627



Are popular psychological tests making us crazy? Find out in today's Living Section, I-C.

One local call places a want ad in over 84,000 homes through the following newspapers: Northville Record (313)348-3022, Walled Lake News (313)669-2121, South Lyon Herald (313)437-4133, Milford Times (313)685-8705, Brighton Argus (313)227-4436, County Argus/Pinckney Post (313)227-4437, Country Argus/Hartland Herald (313)227-4436, Fowlerville Review (517)548-2570, Livingston County Press (517)548-2570

RATES GREEN SHEET ACTION ADS 10 Words for \$4.49, Non-Commercial Rate 24 Per Word Over 10, Classified Display Contract Rates Available, Want ads may be placed until 3:30 p.m. Monday, for that week's edition.

absolutely FREE 001 Absolutely Free 001 Absolutely Free, Beautiful Calico cat (Mona), Needs good home, short haired, brown eyes.

Are You Bored, Depressed, Unemployed? LEARN MORE and LEARN MORE! Pontiac Business Institute offers: Quality Career Training in: Class Processing, Word Processing, Accounting, Medical, Legal, Executive Secretarial, Medical Assisting, Financial Aid Available, Job Placement Assistance.

For straight talk about IRAs, attend our free seminar. When you're putting your money into an IRA, it's important to get all the facts, so you can make the right investment decision.

Attend a Free IRA Seminar In simple language, you'll learn what an IRA can and should do for you... and how to select the best investment options for your personal IRA program. There's no obligation. So reserve your place today!

Sliger/Livingston Publications GREEN SHEET EAST CLASSIFIED ACTION ADS

001 Absolutely Free 001 Absolutely Free 001 Absolutely Free 001 Absolutely Free 001 Absolutely Free, VERY friendly Sheltie mix and Shepherd mix. Need good homes. (313)246-0702.

Make Someone Happy THIS YEAR YOU CAN SEND Happy Valentine Ads. Send personal VALENTINE GREETINGS to the ones you love. You can place a happy Valentine ad in the Wednesday, February 13 edition of this newspaper for only \$5.00.

VALENTINE GREETINGS Send personal VALENTINE GREETINGS to the ones you love. You can place a happy Valentine ad in the Wednesday, February 13 edition of this newspaper for only \$5.00.

Our classified counselors will be happy to help you word your message. Send your Valentine something like this: VALENTINE Greetings to you & Dad! Love, Joan and Jim.

Little Happy Heart only 50¢ extra or the Big One just \$1 more. Northville, 348-3022—Novi, 348-3024—Walled Lake, 669-2121—South Lyon, 437-4133—Brighton, 227-4436—Livingson County, 548-2570—Milford, 685-8705.

Form for placing a Valentine ad. Includes fields for Name, Address, Phone No., and a section for selecting ad options (Happy Valentine \$5.00, Small Happy Heart \$3.00, Large Happy Heart \$1.00).

015 Lost SMALL female cat, long hair, black and white, lost in parking lot behind W. D. Adams Road, Brighton area. (517)223-7295, (517)548-5554.

021 Houses For Sale BRIGHTON, 3 miles north. New 3 bedroom bi-level under construction. 2 car garage. Excellent sub with paved roads and driveway. \$25,900. (517)223-7295, (517)548-5554.

021 Houses For Sale BRIGHTON, 3 miles north. New 3 bedroom bi-level under construction. 2 car garage. Excellent sub with paved roads and driveway. \$25,900. (517)223-7295, (517)548-5554.

021 Houses For Sale BRIGHTON, 3 miles north. New 3 bedroom bi-level under construction. 2 car garage. Excellent sub with paved roads and driveway. \$25,900. (517)223-7295, (517)548-5554.

021 Houses For Sale BRIGHTON, 3 miles north. New 3 bedroom bi-level under construction. 2 car garage. Excellent sub with paved roads and driveway. \$25,900. (517)223-7295, (517)548-5554.

021 Houses For Sale BRIGHTON, 3 miles north. New 3 bedroom bi-level under construction. 2 car garage. Excellent sub with paved roads and driveway. \$25,900. (517)223-7295, (517)548-5554.

1984 MODEL CLOSE-OUT BRAND NEW 1600 Sq. Ft. Cape Cod Full Price \$62,900 Down Payment \$3,200 WE PAY YOUR CLOSING COSTS M.S.H.D.A. FINANCING 10.95% A.R.M. 9.25% WELCOME HOMES

021 Houses For Sale HARTLAND, 4 bedrooms, 2 1/2 baths, full basement, brick fireplace, full kitchen, full bathroom, full laundry room, full garage. \$48,500. (517)223-7295, (517)548-5554.

021 Houses For Sale HARTLAND, 4 bedrooms, 2 1/2 baths, full basement, brick fireplace, full kitchen, full bathroom, full laundry room, full garage. \$48,500. (517)223-7295, (517)548-5554.

021 Houses For Sale HARTLAND, 4 bedrooms, 2 1/2 baths, full basement, brick fireplace, full kitchen, full bathroom, full laundry room, full garage. \$48,500. (517)223-7295, (517)548-5554.

021 Houses For Sale HARTLAND, 4 bedrooms, 2 1/2 baths, full basement, brick fireplace, full kitchen, full bathroom, full laundry room, full garage. \$48,500. (517)223-7295, (517)548-5554.

021 Houses For Sale HARTLAND, 4 bedrooms, 2 1/2 baths, full basement, brick fireplace, full kitchen, full bathroom, full laundry room, full garage. \$48,500. (517)223-7295, (517)548-5554.

021 Houses For Sale HARTLAND, 4 bedrooms, 2 1/2 baths, full basement, brick fireplace, full kitchen, full bathroom, full laundry room, full garage. \$48,500. (517)223-7295, (517)548-5554.

1984 MODEL CLOSE-OUT BRAND NEW 1600 Sq. Ft. Cape Cod Full Price \$62,900 Down Payment \$3,200 WE PAY YOUR CLOSING COSTS M.S.H.D.A. FINANCING 10.95% A.R.M. 9.25% WELCOME HOMES

025 Mobile Homes For Sale WYOMING, 1981 14 wide, like new, reduced to \$14,500. Great location, close to schools, shopping, and recreation. (517)223-7295, (517)548-5554.

WORK FOR TOP PAY AT TOP CUSTOMERS Secretaries Typing 55 wpm Shortland 80 wpm Word Processing Operators Typing 35-40 wpm Data Entry Operators Long & Short Term Temporary Assignments

NICHOLS REALTY INC. 348-3044 READY TO BUILD? Farmington, Randall Street 100 x 400, \$13,900. Salem 7 Mile, 3 Acres \$28,900. Brighton, Clark Lake, 67 x 134, \$12,000.

DARLING Mobile Homes on Novi Rd. Novi 349-7511 The best selection of pre-owned homes at reasonable prices with good financing.

NOVI MEADOWS APARTMENT DWELLERS Are you tired of investing in your landlords? Are you tired of making payments without building equity? Are you tired of paying higher rents because you own?

PETERSON REALTY Co. 335 North Center St. Northville, Michigan 348-1323

GLOBAL HOMES, INC. Your Listing & Selling Brokerage Now's the Time To Sell Your Manufactured Home PROFESSIONAL SERVICE & EVALUATIONS Call Diane or Carola 689-9030 Cetera Novi

Buying in Livingston County Saves Dollars and Makes Sense!

8.8%

ALL THE INTEREST YOU NEED TO PAY*

ON OMNIS, HORIZONS, TOURISMOS

Amount Financed	\$5,500	\$6,000	\$6,500	\$7,000	\$7,500
Payment*	\$118.22	\$128.96	\$139.71	\$150.45	\$161.20

*80 months approved credit at 8.8%
We Don't Want to be the Biggest—We Want to be the Best!

LIVINGSTON COUNTY DODGE TRUCK HEADQUARTERS
John Colone
Chrysler, Plymouth, Dodge, Inc.

Dodge SALES • SERVICE • PARTS **CHRYSLER**
Dodge Trucks 878-3152 or 878-6086 **Plymouth**

Mitchell Chevrolet-Oldsmobile

'80 OLDS CUTLASS	\$4995
'80 FORD FIESTA	\$2295
'78 CAPRICE	\$4295
'79 DELTA ROYALE	\$3995
'82 DELTA ROYALE	\$7995
'81 PONTIAC GRAN LEMANS	\$5595
'82 CUTLASS SUPREME	\$7395
NEW '84 CONVERSION VAN	\$14,500

307 W. Grand River, Fowlerville
517-223-9129 OPEN SATURDAYS

Discover Your Livingston County Auto Dealers

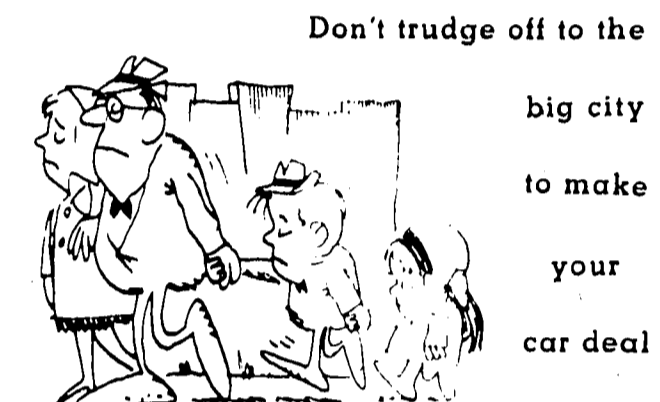

—when everything you need is here at your doorstep!

OUR PRICES

Warm up your winter in a new car from Brighton Chrysler-Plymouth!

1984 Mazda B26 2 dr., loaded, 5 spd., air, roof rack, cassette, stereo, 45,000 miles. ONLY	1978 Toyota Corolla SR 5 Great shape. ONLY	1980 Plymouth Fire Arrow 2.6 engine, 5 spd., sunroof, road wheels. ONLY
\$8995	\$2295	\$3495
1982 LeBaron 2 dr., auto, air, p.s., p.b., stereo, cloth interior. ONLY	1984 Laser Auto, p.s., p.b., tilt, cruise, air, low miles. ONLY	1979 Mercury Zephyr Station wagon, auto, p.s., p.b., air, wire wheels
\$6395	\$8295	\$2195
1982 Buick Regal Estate Wagon Auto, air, p. locks, tilt, cruise, stereo, luggage rack, 47,000 miles. ONLY	1982 Chevette 4 dr., air, only 34,000 miles.	1982 Chevrolet S-10 Pick-Up Auto, V-6, p.s., p.b., cab. ONLY
\$5995	\$3895	\$4695
1984 Dodge D-150 Pickup V8, auto, p.s., p.b., AM/FM stereo, cassette, 12,800 miles.	1979 Ford Pinto 4 spd., air, nice shape & economical.	1982 Reliant SE 4 dr., auto, air, stereo, (rear defrost), 40,000 miles.
\$7995	\$2595	\$4995
1982 Camaro Z-28 Auto, p.s., p.b., cassette, 30,500 miles, excellent condition.	1984 Escort Wagon GL Auto, air, cruise, stereo.	1985 Chrysler Laser XE Fully loaded, only 1500 miles, better than new!
\$7995	\$6995	\$12,995

BRIGHTON CHRYSLER-PLYMOUTH-DODGE

Most Vehicles Include Chrysler Corporation's Used Car Warranty

As Is Transport Specials . . .

1975 Chevy Beauville Van	\$799	1978 Pontiac Sunbird	\$995
1976 Ford Econoline Van	\$999	1978 Chevy Malibu Wagon	\$1495
1973 Chevy 3/4 Ton Pickup	\$799	1978 Plymouth Arrow	\$1595

9827 E. Grand River Brighton
(313) 229-4100
Open: Mon. & Thurs. 8-9
Tues., Wed. & Fri. 8-5
Sat. 10-2

Chrysler
Plymouth
Dodge

It's SNOWTIME . . . Go For It In A

1985 RANGER 4 WHEEL DRIVE Stock No. 5T208

5-P195/75R15 tires, amp & oil gauges, black step bumper, tinted glass, western mirrors, p.s., auto., V-6

\$9695 Plus shipping, tax & title

1985 MERCURY GRAND MARQUIS

Includes: six passenger room, 5 liter V6 engine, auto. overdrive, p.s., p.b., p. windows, AM/FM stereo, white sidewall tires, vinyl roof, power locks, auto parking brake release, tilt wheel, speed control, tinted glass, wire wheel covers, right hand remote mirrors, air cond., electric rear defrost. 3M132.

Until January 31, 1985 add 4% use tax

\$23152 Per Month

A-1 USED CARS . . . ALL PRICED TO GO!

'84 Cutlass Supreme Brougham	'83 Chevy S10	'80 LTD	'80 Ford F100
\$9495	\$5995	\$4995	\$6995
'84 Chevy S10	'80 Lemans	'80 Fairmont Futura	'79 Ford F150
\$6895	\$3695	\$3695	\$4495
'84 Colony Park Wgn.	'81 LTD	'80 Cougar XR7	'79 Bronco
\$12,695	\$3995	\$5395	\$5995

WILSON FORD & MERCURY **BUY or LEASE**

8704 W. Grand River
Brighton-Next to Meijer's-227-1171
Open Mon. & Thurs. eves. 'til 9 Open Sat. 10-2

LIFETIME SERVICE GUARANTEE

Buying in Livingston County Saves Dollars and Makes Sense!

Discover Your Livingston County Auto Dealers

WALDECKER

We're Moving Feb. 1st
Over 250 Cars Priced To Sell Now Before We Move
Now thru Jan. 31st
NO REASONABLE OFFER REFUSED
THEY ALL MUST GO!

USED CAR CLOSE OUT, OVER \$325,000
WORTH OF USED CARS MUST GO!

New 1984 Buick Pontiac Sunbird Stk. No. 1344 \$6995 or \$13487 per mo. Plus tax, title, plates	New 1984 Buick Regal Stk. No. 1147 \$8995 or \$17987 per mo. Plus tax, title, plates	1985 Buick LeSabre 4 dr., Stock No. 1639 \$9995 Plus tax, title, plates
New 1984 Buick LeSabre Ltd. SAVE UP TO \$2500 left in stock!	1985 Pontiac T-1000 ONLY \$9900 per mo. plus tax, title, plates	1984 Pontiac Fiero Hurry only 2 Left! Save \$100's!
1985 Jeep Cherokee 100 Below Dealer Invoice (thru 1-31-85 only)	1985 Renault Alliance 100 Below Dealer Invoice (thru 1-31-85)	1985 AMC Eagle 100 Below Dealer Invoice (thru 1-31-85 only)

ATTENTION: GM EMPLOYEES
Get an option 1 Price on a New Pontiac or Buick in stock! Why order, when you could be driving now!

11.5% AV. INTEREST Livingston County's Largest Inventory

1985 Buick Park Avenue 6 in stock Save \$100's!	1985 Buick Century 15 in Stock SAVE UP TO \$1000!
---	--

PONTIAC • BUICK
WALDECKER
AMC | Jeep | Renault

9797 E. Grand River
Brighton
(313)227-1761

Hours: Mon. & Thurs. 8-9; Tue.-Wed.-Fri. 8-6; Sat. 10-3

3 Reasons to buy from Waldecker:
1. PRICE—We will not be undersold!
2. VALUE—Great GM Feeling!
3. SERVICE—We'll take care of you after the sale!

All payments based on \$1,000 down. Cash or trade plus tax, title & plates on approved credit. (All cars subject to resale)

All Cars Subject to Presale

HILLTOP Ford-Lincoln Mercury 546-2250

1975 Camaro	ONLY \$395
1977 Olds Cutlass	ONLY \$1995
1979 Ford Country Squire Wgn	ONLY \$1995
1980 Volare	ONLY \$2595
1981 Zephyr Z-7	ONLY \$3295
1979 LTD	ONLY \$3395
1981 GRANADA	ONLY \$3695
1980 LTD	ONLY \$4495
1980 Civic	ONLY \$4595
1980 T-Bird	ONLY \$4995
1980 Camaro Z-28	ONLY \$5395
1983 Escort GLX	ONLY \$5695
1984 Tempo GL	ONLY \$6395
1984 Lynx RS	ONLY \$6995
The Boss is out of town, we're going to sell this car	
Was Our Discount Lincoln Rebate	\$28,500 \$501.00 \$21,495.00 \$1,500.00
1984 Mark VII LS	ONLY \$19,995.00

Vans & Pick-ups

1981 Ford F-100	ONLY \$4895
1981 F-150 Pick-up	ONLY \$5195
1981 GMC High Sierra Pickup	ONLY \$5295
1982 F-150	ONLY \$5395
1982 F-150	ONLY \$6695
1983 F-150	ONLY \$7695
1984 F-150	ONLY \$7995
1982 Bronco 4x4	ONLY \$8095
1983 Ford Club-Wagon	ONLY \$9295
1983 Ford Van Tra-Tech Conversion	ONLY \$9995
1983 Chevy Beauville Window Van	ONLY \$9995
1983 Ford Club-Wagon	ONLY \$10,995
1972 Executive 28 Ft. Motor Home	ONLY \$13,995

Every option, fully reconditioned

OPEN SATURDAYS
INSTANT FINANCING

HILLTOP FORD, LINCOLN, MERCURY
A NICE PLACE TO DO BUSINESS
HOWELL Since 1968 **517/546-2250**



Now, famous Marlboro Red and Marlboro Lights are also available in a convenient new 25's pack.

For smokers who prefer the convenience of five more cigarettes per pack.

New Marlboro 25's

Warning: The Surgeon General Has Determined That Cigarette Smoking Is Dangerous to Your Health.

Lights 11 mg "tar," 0.7 mg nicotine - Kings 17 mg "tar," 1.1 mg nicotine av. per cigarette by FTC method.

Not available in some areas. © Philip Morris Inc. 1984

WHY WAIT FOR A SALE...
CARTER
HAS THEM EVERY DAY

INSULATION

SWAP UP INSTANT ENERGY SAVINGS

Patented 6000 Insulation Cells when you buy 10 rolls or more of Owens-Corning pink fiberglass insulation. Carrying cases with one-year warranty. No-fussing necessary. Just aim and shoot.

8" x 15" \$9.89
8" x 23" \$15.25
R-25/6'

SANDED PLYWOOD

• Good one side
• 1/2" or 3/4"
• 4' x 8' sheets

3/8" \$10.19
3/4" \$16.79

6' STEP LADDER

WOOD

\$28.95
OTHER SIZES AVAILABLE

PRE-FINISHED PANELING

6" x 8' PANELS

\$3.99
Autumn Oak

FIBERGLASS INSULATION

Size	R-Value	Style	Sq. Ft. Total	Sq. Ft. Price
3 1/2 x 15	R-11	Kraft Only	88 sq. ft.	.15
3 1/2 x 23	R-11	Kraft Only	135 sq. ft.	.15 1/4
6 x 15	R-19	Kraft Only	49 sq. ft.	.24 1/4
6 x 15	R-19	Unfaced Only	49 sq. ft.	.24 1/4
6 x 23	R-19	Kraft Only	75 sq. ft.	.25 1/4
6 x 23	R-19	Unfaced Only	75 sq. ft.	.24 1/4
9 x 15	R-30	Kraft Only	59 sq. ft.	.43 3/4
9 x 23	R-30	Kraft Only	80 sq. ft.	.43 3/4

LATEX INTERIOR WALL PAINT

• Custom mixed colors available with soap and water
• Better or Best

\$6.99 \$11.99
Gal. Gal.

WOOD FIBER INSULATION

• Covers 25 sq. ft.
• All 1 1/2" thick
• 1 lb. bag
• Won't Scratch or Flch.

R-19 \$2.99
BAG

INTERIOR PREHUNG DOOR

24" L x 80" H
Your Choice 2" or 2 1/4" or 2 3/4"

\$29.99
30" x 36" and 36" x 36" ALSO AVAILABLE

ENTRY LIFETIME WARRANTY

\$6.65

PONDEROSA PINE BOARDS

• Choose from a large selection
• Priced per lineal foot.

1" x 6"	18¢
1" x 8"	23¢
1" x 10"	30¢
1" x 12"	44¢

CEILING PANELS

MONPACO No. 185-1/2" \$2.35

White No. 188-1/2" \$1.99

WAVERLY GIBS A No. 192-1/2" \$2.25

A special advertising supplement to The South Lyon Herald, The Milford Times, The Novi News and The Northville Record, the Green Sheet newspapers

UP TO **50% OFF** AND MORE

January 30, 1985

Shoppers Catalog

Every Merchant will be Slicing Price Tags on Selected Merchandise up to 50% and More

Hours: Mon-Fri 7:30-6
Sat 7:30-6
Sun 11-4



CARTER LUMBER
1818 W. Grand River
Webberville
(517) 521-4180

CARTER LUMBER
1818 W. Grand River
Webberville
(517) 521-4180



Prices Effective Until February 13, 1985

Shop these three stores for super savings.

50% OFF

Up To Savings

Available at:

- MILFORD**
435 N. Main St.
885-9401
Mon.-Sat. 9-6; Fri. 9-9
- HOWELL**
1225 E. Grand River
546-2788
Mon.-Fri. 9-6; Sat. 9-6; Sun. 12-5
- SOUTH LYON**
120 E. Lake St.
437-1740
Mon.-Sat. 9-6; Fri. 11-8

PLUS ASSORTED MEN'S WINTER MERCHANDISE

- Men's Suits
- Men's Sportswear
- Men's Casual Wear
- Men's Knitwear
- Men's Footwear
- Men's Accessories
- Men's Grooming Products
- Men's Outerwear
- Men's Children's Outerwear
- Men's Children's Suits
- Men's Children's Sportswear
- Men's Children's Knitwear
- Men's Children's Footwear
- Men's Children's Accessories

FURTHER REDUCTIONS ON WHAT YOU WANT MOST NOW

Additional 20% will be reduced on exciting clearance fashions in every department. Starting today!

Dancer's Fashion's Winter Clearance Sale Continues!

Take an additional 20% off our previously reduced clearance prices!

South Lyon
437-5319

22371 Pontiac Trail
In Brookdale Square

Gerri's Hallmark Shoppe

- Large selection of Christmas Items
- available
- Dakin Animals
- Costume Jewelry
- Music Boxes
- Stickers

40 to 50% OFF

Select Merchandise

BARGAIN DAYS

SALE ENDS SATURDAY, FEBRUARY 9

FREE Engraved Name Plate with purchase. Grandfather clocks include delivery and setup in S.E. Michigan. *25% additional for delivery anywhere else in Michigan or continental U.S.A. Phone and mail orders accepted.

Hours: Mon., Thurs. & Fri. 9-5
Tues., Wed. & Sat. 9-6; Sun. 12-5
Limited Quantities On Some Models

ANDERSON FAMILY CLOCK SHOPS

- Northville**
132 W. DUNLAP
(1 block N. of Main off Sheldon Rd.)
349-4938
- Dearborn**
22371 NEWMAN
(1 block S. of Michigan at Milliken)
563-7345
- Troy**
1117 E. LONG LAKE RD.
588-3989

Next Generation Watch & Clock Shop
132 W. DUNLAP
349-4938

Ewitt's Clock World
22371 NEWMAN
(1 block S. of Michigan at Milliken)
563-7345

Anderson's Clock World
1117 E. LONG LAKE RD.
588-3989

Mid-Winter Clearance

Startling today in every department exciting clearance fashions will be reduced an additional 20%.

FURTHER REDUCTIONS ON WHAT YOU WANT MOST NOW

- Men's Suits
- Men's Sportswear
- Men's Casual Wear
- Men's Knitwear
- Men's Footwear
- Men's Accessories
- Men's Grooming Products
- Men's Outerwear
- Men's Children's Outerwear
- Men's Children's Suits
- Men's Children's Sportswear
- Men's Children's Knitwear
- Men's Children's Footwear
- Men's Children's Accessories

CO. Connolly's Carpet

Prices valid thru Feb. 13, 1985

MOHAWK CARPET SALE
A spectacular new fashion multi-color system creating a soft-wicker-like effect. Made with nylon extra body fibers which provides a soft-wicker-like effect. Made with nylon extra body fibers which provides a soft-wicker-like effect. Made with nylon extra body fibers which provides a soft-wicker-like effect. Made with nylon extra body fibers which provides a soft-wicker-like effect.

\$14.99

MOHAWK CARPET SALE
A subtle blending of contemporary colors in a carpet that is as soft as silk and as durable as steel. Plus nylon is your design offers up to six different color combinations. Long lasting, low pile, and 15% extra for extra beauty and long wear life. Available in 10% nylon for extra beauty and long wear life. Available in 10% nylon for extra beauty and long wear life. Available in 10% nylon for extra beauty and long wear life.

\$13.99

MOHAWK CARPET SALE
A splendid new look featuring a smooth flow of color designed to go anywhere in your home. Made of Durofil nylon to assure soil, stain, and wear protection.

\$11.50

MOHAWK CARPET SALE
A splendid new look featuring a smooth flow of color designed to go anywhere in your home. Made of Durofil nylon to assure soil, stain, and wear protection.

\$9.50

MOHAWK CARPET SALE
A splendid new look featuring a smooth flow of color designed to go anywhere in your home. Made of Durofil nylon to assure soil, stain, and wear protection.

\$10.99

MOHAWK CARPET SALE
A splendid new look featuring a smooth flow of color designed to go anywhere in your home. Made of Durofil nylon to assure soil, stain, and wear protection.

\$7.99

MOHAWK CARPET SALE
A splendid new look featuring a smooth flow of color designed to go anywhere in your home. Made of Durofil nylon to assure soil, stain, and wear protection.

FIBER CARPET SALE

South Lyon
437-5319

22371 Pontiac Trail
In Brookdale Square

Gerri's Hallmark Shoppe

- Large selection of Christmas Items
- available
- Dakin Animals
- Costume Jewelry
- Music Boxes
- Stickers

40 to 50% OFF

Select Merchandise

BARGAIN DAYS

134 S. Midland Rd.
Highland
(next to Star Panes Man)

Mon. - Thurs. 10-6
Fri. 10-5
Sat. 9-6; Sun. 12-5

HURRY! Sizes are limited!

Further Reduction on All Sale Merchandise

• Moon Boots
• Red Wing
• Wolverine
• Sorels

50% OFF

ARE NOW

BOOTS

INSULATED

Are Falling Like The Snow

Our Prices

3131 887-1700

ERA

NOW THERE REALLY IS A DIFFERENCE IN REAL ESTATE COMPANIES.

RYMAL SYMES - Realtors Since 1923 -

We're stronger because we've joined ERA Real Estate. For you that means innovations and services like these:

- **ERA Sellers Security Plan™**
If we don't sell your home, we'll buy it.* Up to \$100,000 equity advance before your present home sells.
- **ERA Buyer Protection Plan**
Protection from major unexpected repair bills for buyers. Protection for sellers, too, while their home is still on the market.
- **ERA Moving Machine™**
A free, exclusive ERA service that transmits a photograph and description of your home to the 40% of home buyers who come looking from out of town. It can also help you preselect homes in another city without ever having to leave town.
- **FREE Home Evaluation™**
Complete, no-obligation assessment of your home's real estate market value. Plus a projection of trends influencing your neighborhood.
- **Low Interest Financing:**
ERA uses our national muscle and financial resources to find the perfect financing plan with the most competitive interest rate, to fit your lifestyle and your budget. And it's convenient, you can apply for your loan in our office.

When it comes time to sell your present home or buy a new one, remember the muscle of ERA Real Estate. We invite you to compare.

There really is a difference in real estate companies.

Conrad Jakubowski
Mary Ann Schmeltzer
Inez Marks
Fil Superfisky
Ginny Wolfe
Maggie Walker

Terry Thomas
Dee Sumiec
Helen South
Roberta Roberts
Lily Lester
JoAnn Kissel

Tom Sumiec
Jane Traudt

NOVI • NORTHVILLE 478-9130

FARMINGTON • W. BLOOMFIELD 851-9770

RYMAL SYMES COMPANY, REALTORS®

MID-WINTER CLEARANCE

Cherry, No. 810-232 Oak, No. 810-239 Cherry, No. 612-437 Cherry & Elm Burd, No. 881 Cherry & Manogany, No. 874

599 699 799 1099

All the famous names in clocks at prices that say "this is the time, this is the place."

Mid-Winter Clearance

FREE Engraved Name Plate with purchase. Grandfather clocks include delivery and setup in S.E. Michigan. *25% additional for delivery anywhere else in Michigan or continental U.S.A. Phone and mail orders accepted.

Hours: Mon., Thurs. & Fri. 9-5
Tues., Wed. & Sat. 9-6; Sun. 12-5
Limited Quantities On Some Models

ANDERSON FAMILY CLOCK SHOPS

- Northville**
132 W. DUNLAP
(1 block N. of Main off Sheldon Rd.)
349-4938
- Dearborn**
22371 NEWMAN
(1 block S. of Michigan at Milliken)
563-7345
- Troy**
1117 E. LONG LAKE RD.
(at Rochester Rd.)
588-3989

VALENTINE'S DAY

February 14, 1985

Say it with "Masters Candies" the finest of chocolates at: **The Ball Carriage**

Located in the Colonial Village Shopping Center
1427 S. Midland Road • 1 1/2 Miles South of I-249
Highland, Michigan 48031
(313) 887-0300

VISA / MASTERCARD

TOUCH OF COUNTRY SHOPPE

48" Round Table with 2-12" leaves, 4 Double Pressed-Back Chairs

\$750.00

ALSO AVAILABLE
Oak Hutches & Curio Cabinets
Decks & Library Units
Hail Trees & Rockers

PLUS: Stoneware
Cast Iron Toys
Collectible Dolls

TOUCH OF COUNTRY SHOPPE

OPEN 5640 M-29
Wed., Thurs., Fri., Sat. 10-5 East of Howell 546-5995

Next Generation Announces the opening of its

Milford Store!

We're Celebrating with

1/2 OFF Merchandise*

Sale starts Thursday, Jan. 31st.
(*1/2 Off at Brighton Store only)

Next Generation
Sizes Infant thru 16
Preteen and Student Size
Now 2 Convenient Next Generation locations to serve you better

BRIGHTON 209 W. Main 227-9556
OPEN: M-F 9:30-6 Sat 9:30-6 Sun 12-5

MILFORD 417 N. Main 685-9414
OPEN: Mon-Sat 10-6 Thurs & Fri 11:8 p.m.

SUPER SALE

In Stock offers you one stop shopping for a great selection of window treatments and wallpaper.

Buy first roll at regular price
Get second roll **50% OFF**

Great selection • Displays
New Patterns Arriving Daily

We have a full line of window treatments offering you discounts of 25% to 50% off suggested retail.

Blinds 40% OFF
ALL GRABER BLINDS 40% OFF

(Displays throughout Store)
From our full line of window treatments, our blind prices are suggested retail. The discount is applied. Don't be fooled by double discount gimmicks. Our discounts give you the most for the least!

In Stock WALLPAPER, INC.

Open 7 Days
Mon.-Fri. 10 A.M. - 9 P.M.

NOVI • BLOOMFIELD CENTER 478-9130
LIVONIA 478-9130
NOVI • BLOOMFIELD CENTER 478-9130

KITCHEN SUPPLIERS INC.
 9325 MALTBY ROAD BRIGHTON 229-9554
 Hours: Mon.-Fri. 8:00-5:00, Sat. 9:00 to 3:00 p.m., Thurs. 11:00 to 8:00 p.m.

ANN ARBOR & CLARKSTON
 7012 Dixie Hwy., Clarkston, 625-7669

We have placed kitchens in over 20,000 homes since 1971

• Member of American Institute of Kitchen Bath
 • Member of Livingston County, Washenaw,
 North Oakland Builders Association
 • Dealers

Appliances Available - All Beautifully Displayed

CRYSTAL
Quaker Maid

Design Service-Counter Tops-Installation Available-Lay-A-Way Plan
 Installation Available
 Do-It-Yourself Or

DO-IT-YOURSELF DREAM KITCHEN
 You can have the kitchen you always wanted... Designed for function and style at a price you can afford.

New Hudson Power
 5353 Grand River at Haas
 Hours: Mon-Fri. 9-6, Sat. 9-3
 (313) 437-1444

Cash and Carry
 Limited Quantities

Bar and Chain Oil
 Reg. \$7.95 gal.
 Sale \$3.95 gal.

Buy A Pro Bar
 Get A Free Chain
 16" Super XL \$400
 18" Super XL \$440
 20" Super XL \$480

CHAIN SPECIALS
 18" Super XL \$12.99
 16" Super XL \$11.99
 14" Super XL \$10.99
 12" Super XL \$9.99
 10" Super XL \$8.99
 8" Super XL \$7.99
 6" Super XL \$6.99
 4" Super XL \$5.99

20" Ship Snow
 Reg. \$249.95
 Sale \$199.95

20" Snow Blower
 Reg. \$199.95
 Sale \$149.95

20" Snow Blower
 Reg. \$199.95
 Sale \$149.95

New Hudson Power
 (313) 437-1444

Reg. \$545.00
 Sale \$259.95

220 H Tractor, Blade & Chains

Reg. \$475.00
 Sale \$359.95

16 hp Tractor, Blade & Chains

With 85 Tractors

Going All Out For Business

BARGAIN BARN
 5640 M-59, Howell • 546-5995

Tools	Reg. Sale
55 pc. W. Dr. Socket	\$10.00
AM-700 Cassette	\$39.95
11 pc. Wrench Set	\$7.95
7 Channel Equalizer	\$39.95
10 Channel Equalizer	\$49.95
635 Speaker & Amp 500	\$19.95
Radio	\$89.00

SALE
 35% OFF
 5% LAZARUS

MIDWEST DOOR SALES, INC.
 6777 Highland Rd. (M-59)
 887-8305
 Hours: Mon.-Fri. 8 a.m. to 5 p.m.

Offers good thru February 1985

Garage Door Openers
 Super Special
 \$14900 plus 1/2 off installation

Garage Door
 Beautiful
 Steel Panel
 Raised Panel
 Replace That Tired Old Garage Door Now!

SECTIONAL EMBOSSED
 15' x 7' \$425
 16' x 7' \$495
 18' x 7' \$595

ONE PIECE EMBOSSED
 15' x 7' \$262
 16' x 7' \$295

Other sizes & styles available. See our showroom for more information.

Steel Panel
 Raised Panel
 Steel Panel
 Raised Panel

Northville Camera
 105 E. Main St.
 Northville
 349-0105

Open Daily 9-6, Fri. 9-7
 Closed Sunday

Buy 2 Enlargements
 Get a 3rd FREE

Offer applies to 8x10 to 16x24
 Kodak Color Enlargements
 (5x7 size excluded)
 Offer runs Jan. 21-Feb. 27, 1985

GREEN'S HOME CENTER
 107 N. Center St.
 Northville • 349-7110
 Mon., Fri. 8:00-11:00, Tu., Th., Sat. 8:00-9:50

With the help of
 Green's Home Center of course!
 It's no mystery that Briggs the Butler chose this time to redecorate because Green's is having a spectacular winter sale!

SALE!!

WALLPAPER
 Carefree & United Books
 35% OFF

Strahan, Benchmark
 Tribout & Many Others
 30% OFF

Kirsch Metal Mini Blinds
 50% OFF

Omin Metal Blinds
 60% OFF

Fuller O'Brien Interior
 2.00 Off Gallon
 Paint

We will give you our now-to assistance for all your home decorating projects!

JOBIN'S
 Upholstery & Decorating Shoppe
 644 E. Huron St. Midland • 685-2813

Free In-Home Measuring Service

50% OFF!!

Blinds & Vertical
 Shades

Paint • Rollers • Brushes
 New Available

ALL IN-STOCK INVENTORY
 20-50% OFF

Carpet Classics
 in the Highland Plaza

STOREWIDE SALE

- Carpet
- Vinyl
- Hardwood
- Ceramics
- Wallpaper

Prices Slashed From
20-40% OFF

Room Size Remnant Clearance
50% OFF

Other Remnants from \$10.00 ea. & up
 Throw Rugs 18" x 27" \$3.00 ea.

CASH & CARRY

Carpet Classics
 2928 E. Highland Rd.,
 (M-59) at Duck Lake Rd.,
 Highland Highland Corners
 887-6050
 Mon.-Sat. 10 a.m. 'til 6 p.m.

THE HEALTH NUT
 Prices good thru 2-14-85
 NATURAL FOOD MARKET
 401 W. Main, Downtown Brighton
 HOURS: Mon.-Fri. 9-8, Sat. 9-6, Sun. 12-5 227-5300

FREE NUTRITIONAL COUNCILING
 By BRENDA SZENAY, Owner of Health Nut
 By Appointment Only

SUPER GRAPEFRUIT PILLS
 100% Grapefruit
 100 tabs Reb. \$9.95
\$5.50

DRIED FRUIT BONANZA

RAISINS	Reg. \$1.09 lb.	Papaya Spears	SALE \$2.69 lb.
PINEAPPLE WEDGES	Reg. \$2.89 lb.	PLUMP TURKISH APRICOTS	Reg. \$2.29 lb.

NUT MEAT SPECIALS

PECAN HALVES	Reg. \$4.79	\$3.99 lb.
WALNUTS	Reg. \$3.39	\$2.29 lb.
Almond Meats	Reg. \$3.99	\$2.99 lb.
RAW Pumpkin Seeds	Reg. \$4.79	\$3.99 lb.
Brazil Nuts	Reg. \$3.99	\$3.59 lb.
Pancake Mix Multigrain	97c lb.	Pastry Flour 29c lb.

HEALTH NUT COUPON

FREE 2oz. DRY ROASTED PEANUTS
 Expires 2-14-85 with \$5.00 purchase

LECITHIN GRANULES	\$3.99 lb.	BLUEBERRY GRANOLA	Reg. \$1.79 lb.
-------------------	------------	-------------------	-----------------

EVERYDAY VALUE

20% OFF ALL SCHIFF VITAMINS

KYOLIC GARLIC	100 caps. Reg. \$9.51	\$7.29
Tryptophane	30 tabs. Reg. \$9.95	\$6.99

BUY ONE GET ONE FREE

VITAMIN "C"	50 mg. 100 tabs. Reg. \$3.99	\$3.99
B-50	50 tabs. Reg. \$4.99	\$4.99
SUPER "11" DAILY	30 tabs. Reg. \$7.99	\$7.99

FREE BLOOD PRESSURE CHECK
 BY REGISTERED NURSE
 Tues. 10-3; Thurs. 12-5

BE A LOSER... AND BE PROUD OF IT! FREE WEIGHT LOSS CLINIC! On Tues. & Thurs. our nurse will weigh you & we'll talk with you about dieting the safe, healthful way. Nutritional consultant available.

DAVE'S HARDWARE
 introduces
1 HOUR PHOTO

Get a jumbo enlargement FREE Value to celebrate our new

KIS 1-Hour Photo Processing Center

In just minutes we'll give you perfect, clear, colorful prints on genuine Kodak paper from your 110, 126, 135 and disc film. Enlargements in just minutes! Get one 5x7 enlargement with each roll of color print film you bring in.

- 5x7 from 35mm, 4 1/2x6 from 110, Jumbo Print from 126 & Disc.

This offer expires February 10, 1985.

DAVES HARDWARE
 Highland Rd. (M-59) near Duck Lk. Rd., Highland
 9 to 7 Daily, Sat. 9 to 8, Sun. 9 to 4
 887-4646

We use Kodak paper for a good look!

HONDA
 THE NEXT GENERATION.

SALE **2 DAYS ONLY** **SAVE**

FRI. FEB. 1st 8 A.M.-7 P.M.
 SAT. FEB. 2nd 9 A.M.-2 P.M.

GENERATORS

SIZE	SPEC.	REG.	SALE	SAVE
2000 Watts	EB-2200X	\$735	\$635	\$100
3000 Watts	EB-3000	\$1,137	\$975	\$162
4000 Watts	EB-4000	\$1,325	\$1,135	\$190

Honda's new EB2200 construction generator delivers up to 2200 watts of power. And it will run approximately nine hours on one tank of fuel. The reason? Honda's revolutionary new OHV engine. Its new design makes it smaller, lighter, more efficient, and a lot quieter. And Honda's exclusive Oil Alert™ System protects the engine by shutting it off if the oil dips below a safe operating level.

Other features include an Automatic Voltage Regulator, circuit breaker, integrated front panel controls for easy operation, plus a fully transistorized ignition system for sure starts.

2 DAYS ONLY...
 Fri., Feb. 1st
 Sat., Feb. 2nd

SNOWBLOWERS

SIZE	SPEC.	REG.	SALE	SAVE
3.5 hp	HS-35	\$460	\$369	\$91
5.0 hp	HS-50T	\$1,060	\$899	\$161

Honda's HS-35 single stage snowthrower performs like a double stage snowblower. But at a much lower cost. It has an exclusive auger and paddle drive system that makes it semi self-propelled. The discharge chute adjusts two ways and rotates a full 220°. And like all Honda products, it has a reliable Honda engine with Automatic Decompression for fast, easy starts.

IT'S A HONDA
HONDA Power Equipment

Cougar
 "Where Quality Counts!"
 25100 Novi Rd., Novi 348-8864
 1 mile South of 12 Oaks Mall on Novi Rd.
 For optimum performance and safety we recommend that you read the owner's manual before operating the unit. © 1985 American Honda Motor Co., Inc.

Jack's Meat Market
41527 W. Ten Mile • 349-8490
8:30 a.m. - 8:30 p.m.
at Meadowbrook Novi

GROUND BEEF FROM CHUCK 10 lb. \$15.95 20 lb. \$30.00	NEW YORK STRIP STEAKS U.S.D.A. CHOICE \$2.99	PORK LOINS LEAN WHOLE \$1.59	FRUITS & VEGETABLES WE HAVE A COMPLETE LINE OF
POT ROAST BONELESS CENTER CUT ROLLED \$1.99	ROUND STEAKS U.S.D.A. CHOICE CENTER CUT \$1.99	CHICKENS FRESH 69¢	Jumbo Shrimp or King Crab Legs \$9.49
SIDES OF BEEF U.S.D.A. CHOICE \$1.29	HINDQUARTERS U.S.D.A. CHOICE \$1.45		

Step into the Total Bathing Experience

Choose from **Exquisite Selections...**
• Colorful towels, bathings and carpeting
• Medicine cabinets and mirrors
• Family facials, vanity cabinets and tops
• Decorator toilet seats & bath scales
• Shower curtains • Hamper • Soap
• Detergent • Towels • Bath mats
• Towel rack • Towel warmer
• Towel warmer • Towel warmer
• Towel warmer • Towel warmer

1/2 OFF Original Price
SELECTED GROUP OF
Shower Curtains

Longy Bath Boutique
190 E. Main St.
Northville 349-0273
Mon-Thurs 9:30-5:30
Fri-Sat 9:30-5:30

Wilson MARINE
Shop in the Comfort of Our Indoor Showroom—1,000,000 Inventory
NO DOWN PAYMENT! SPRING DELIVERY
6095 W. Grand River, Brighton
(At Lake Chemung)
LIVINGSTON COUNTY
ON THE WATER SINCE 1949
(517) 546-3774
Open 9 to 6 Mon-Sat

17 FOOT SPORT DECK BOAT
170 ELITE
\$11,925

23 FOOT CHRIS CRAFT SPORT BOAT
230 S SCORPION
\$19,995

Get Boat Show Prices Now!
15 Year Financing

THE '85 BAYLINERS ARE HERE!
SPECIAL PREVIEW SALE
BUY NOW AND SAVE!
AMERICA'S GREATEST BOATING VALUES

1400 CAPRI BOWIDER
Amazingly affordable family sport boat with a complete 15 hp. Force outboard, deluxe interior, LARC pack and a complete 15 hp. Force outboard. Complete with galvanized custom trailer.

BAYLINER 1710
NOW ONLY \$4,588

1700 ELITE
NOW ONLY \$7,188

PRE-Inventory Sale
W & N Oil Paints 30%
Watercolor Paints 30%
Archives Paper 33%
Painting Kits 50%
Books 20%
Stock Frames 25%
Custom Frames 25%

317 N. Lafayette, South Lyon • 437-5404

ANDY'S FRUIT MARKET
42409 Grand River • Novi
East of Novi Rd. 348-2386
Prices good thru 1/15/85

HOMO MILK
1.69

BANANAS
22¢

MUSHROOMS
99¢

POTATOES
79¢

COOKING ONION
3.69

MUNSTER CHEESE
1.69

BEER & WINE AVAILABLE SHOP & SAVE AT DISCOUNT PRICES ANDY'S

Star-Lite Glass Co.
NEW YEARS SPECIAL • 10% Off on Items Listed

FREE ESTIMATES
Call 437-8314

Offer good thru Dec. 31, 1985 with coupon

VALENTINE'S DAY
February 14, 1985
Say it with "Masters Candies" the finest of chocolates at: **Chips Ball Carriage**
1427 S. Main Street / The Corner of M-29
Novi, Michigan 48164
(313) 887-0300

Bootworks
134 S. Highland Rd.
Highland
(313) 887-1700
(next to Stan The Pants Man)

50% OFF
ARE NOW
BOOTS
INSULATED
Like Falling
Our Prices
Are Falling
Like The Snow

Mon-Thurs. 10 to 6
Fri. 10 to 9
Sat. 9 to 6, Sun. 12-5

HURRY! Sizes are limited!
Further Reduction on All Sale Merchandise

• Moon Boots • Red Wing
• Sorbis • Wolverine

to the point

YARN MERCHANT
For the month of February
Select Yarns Offered at
20%-30%-40% & 50% OFF
Sorry, no special orders or layaways

105 Center St., Milford • 684-1003
In the Village Center Mall
Tues.-Fri. 10-5
Sat. 10-4

MICHIGAN ARTIST SUPPLIES
317 N. Lafayette, South Lyon • 437-5404

50% OFF

Come Home to the Country...

We're so proud of our redecorated shoppe with the new country look and can't wait to show it off!!

It's filled with country crafts, hand sewn goods, and beautiful antique pieces.

Gourmet teas, coffees and candies will be sure to tempt your palette.

Custom designed orders in dried and silk flowers.

Hand tied fresh bouquets of flowers, specially priced for cash and carry.

Watch for our new distinctive and nostalgic line of greeting cards, coming soon.

IV Seasons Flowers & Gifts
149 E. Main Northville
349-0671

"A COMPLETE ONE STOP LUMBER & BUILDING SUPPLY HOUSE"

COMPLETE LINE OF BUILDING MATERIALS

NEW HUDSON LUMBER CO.

• PANELING	• INSULATION
• PLYWOOD	• FLUSH DOORS
• BUILDERS HARDWARE	• TRIM & MOULDING
• PLUMBING SUPPLIES	• PRE-HUNG DOORS
• PLASTIC PIPE	• CEILING TILE
• ROOF TRUSSES	• ELECTRICAL SUPPLIES
• CUPRINOL STAINS	• READY-MIX CEMENT

437-1423
56601 GRAND RIVER
NEW HUDSON

SAVE NOW DURING Mid-Winter Sale

30% OFF WALLPAPER
• Laura Ashley • Sanitas • Warner • Milbrook • Thyroy • Taylor • Hoxlephson • Strahn
• And Many More

50% OFF
Lower Drapes, Verticals, Bali & Mini Blinds, Levolor

SAVE ON ALL OUR Custom Window Coverings
Wool Oriental's, Braided Areas & Wall-to-Wall Carpet

Our Designers will help you put it all together in our store or your home!

DON'T INVITE WINTER INTO YOUR HOME!

10% OFF Window Quilt
ON SALE NOW
ASK ABOUT 15% ENERGY TAX CREDIT

The Interior Place
104 E. Huron St., Milford 684-2788

Free Delivery

Just give us a call! We'd be more than happy to send our delivery people right to your door...with your drug needs! Stop in when you have the time and see our complete selection!

(Delivery available in Northville only)

Northville Pharmacy
"Pharmacy first since 1872"
134 E. Main Street
Northville
349-0850

Pousho Plumbing & Heating
2388 E. Highland Rd. (M-59)

Sales & Service

- Water Softeners
- Water Heater Specials
- Electrical Thawing of Frozen Pipes

(FREE phone information on your questions)

\$5.00 OFF Service Call
With this ad. Expires March 1, 1985

All Your Heating & Plumbing Needs

24 Hour Emergency Service
10% Senior Citizen Discount

698-2043 or 887-7561

SALE! SALE!

COUNTRY
Water Conditioning and Feed
TWO LOCATIONS TO SERVE YOU:

13658 Ten Mile Rd. South Lyon (1 Mile West of Pontiac Trail) 437-9136

56807 Grand River New Hudson (1 block East of Milford Rd.) 437-9720

Omolene #200
Premium sweet feed for performance and breeding horses.
Reg. \$6.75
NOW \$5.99
50 lbs.
With this coupon

STORE COUPON

Reg. \$6.12
NOW **\$5.50**
50 lbs.
With this coupon

Layena
For lots of fresh, tasty eggs.

STORE COUPON

Reg. \$6.25
NOW **\$5.50**
50 lbs.
With this coupon

Rabbit Chow
Complete Blend
Complete, life-cycle nutrition.

STORE COUPON

Reg. \$15.75
NOW **\$14.99**
50 lbs.
With this coupon

Dog Chow
America's favorite way to feed its dogs.

All coupons expire February 6, 1985

Beautiful Windows at Beautiful Savings

MINI-BLINDS
PLEATED SHADES
VERTICAL BLINDS
WOVEN WOODS
CUSTOM SHADES

25% TO 50% OFF!

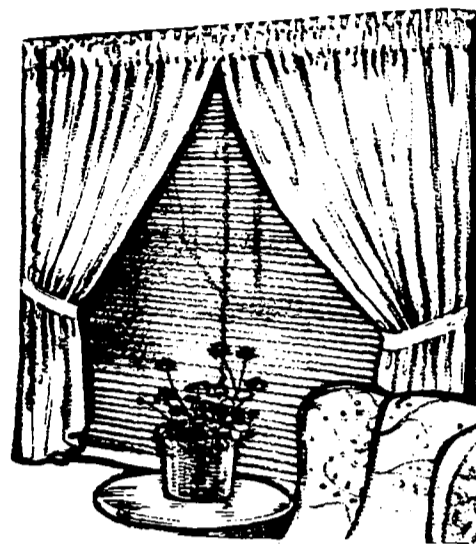

Save Now On Custom
JOANNA Window Treatment Stock Shade Sale
BUY NOW! SAVE NOW! SALE ENDS SOON

SERRA'S INTERIORS
116 N. Lafayette 437-2838



Valentine Day FREE Drawing...

Win A Mongolian Sheep Jacket

(Choice of 3) or \$300 toward purchase of any other fur coat or jacket.

No obligation. Simply fill out the form below, stop by our store, and deposit it in the sealed container. Supervised drawing will be held Thursday, February 14, just in time for Valentine's Day gift giving.

While at our store, don't miss browsing & seeing what values we have to offer during our Winter 50%-60% off Clearance Sale. Many new arrivals, too.

Name _____
Address _____
Phone _____

ONE ENTRY PER CUSTOMER

For Once, For Ever...

onyx furs
international, ltd.

9:30-6 Mon.-Wed.
9:30-8 Thurs. & Fri.
9:30-8 Saturday

133 East Main Street • next to Marquis Theatre
in downtown Northville • (313) 349-4411

VARIETY STORES INC. FASHION
414 N. Main St.
Milford 685-8474

WINTER CLOTHING CLEARANCE SALE
50% OFF
MEN'S, WOMEN'S, CHILDREN'S
Tops, Slacks, Sweaters, Shirts, Garments
Sizes 9M-6X.

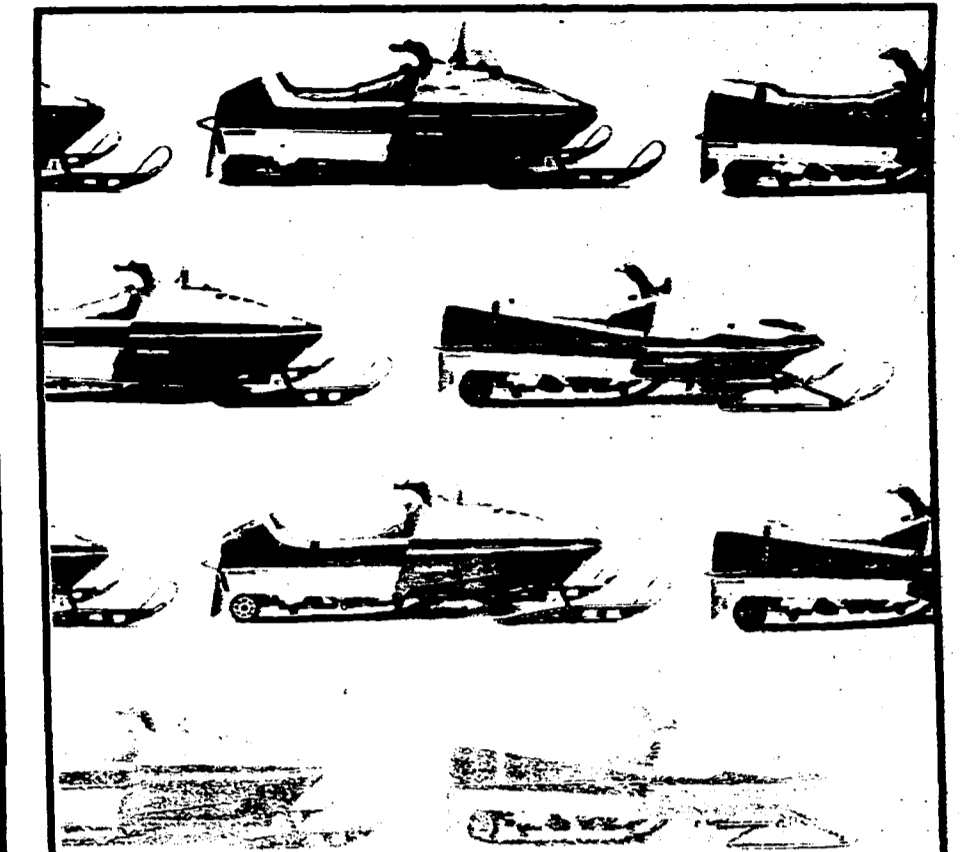

SAVINGS UP TO \$1,000 WILL MAKE OUR MOST POPULAR SLEDS GO EVEN FASTER.

During the Polaris Whiteout Sale, prices on selected 1985 and earlier model Polaris snowmobiles will be reduced as much as \$1,000*. Special savings will be offered on the 1985 Indy Trail and SS — both with lightning-quick 440cc engines — and the Indy 600, the fastest production snowmobile ever built.

Visit your nearby Polaris dealer today. See the Indy Trail, SS and Indy 600. At up to \$1,000 off, they'll be disappearing faster than ever.

*Prices subject to model availability. Dealer preparation, tax and freight not included.

POLARIS WHITEOUT SALE JAN. 12 - FEB. 15

YEAR	MODEL	OLD PRICE	SALE PRICE	YOU SAVE
1985	Indy 600	\$4,999.00	\$3,988.00	\$1,031.00
1985	Indy Trail	3,599.00	2,834.00	765.00
1985	SS	2,899.00	2,297.00	602.00
1985	Star	1,699.00	1,404.00	295.00
1984	Indy 600	4,799.00	3,766.00	1,033.00
1984	Indy Trail	3,599.00	2,794.00	805.00
1984	SS	2,699.00	2,065.00	634.00
1984	Star	1,599.00	1,316.00	283.00
1983	Cutlass SS	2,599.00	2,100.00	499.00
1983	Sport	2,399.00	1,900.00	499.00

POLARIS
The spirit of the sport for thirty years

BAKER'S
LAWN and LEISURE
1550 Milford Road, Highland
(313) 887-2410

Discount Video Rental • Sales • Service
OVER 30 LOCATIONS TO SERVE YOU! OVER 35,000 MOVIES • TV & VIDEO EQUIPMENT • COMPLETE LINE OF VIDEO ACCESSORIES • HOME ENTERTAINMENT FURNITURE • TV ANTENNA'S & INSTALLATION (All Your Video Needs)

Quasar 1985 VCR

- 14 day programmable timer
- Electronic tuning
- Special effects
- One touch recording
- Direct drive quality & dependability.

ZERO DOWN \$10 a month to qualified buyers \$347

HITACHI-EVEREX 1985 VCR

- WITH WIRELESS REMOTE CONTROL
- Front loading top window
- 14 day & event timer
- Electronic tuning
- Infra red remote control
- Special effects

ZERO DOWN \$12 a month to qualified buyers \$467

HITACHI-EVEREX Portable VCR with Dolby

- Stereo w/ Dolby
- 5 head professional model
- Electronic quartz tuning
- 14 day & event timer
- Video & Audio dubbing
- Professional connections

ZERO DOWN \$20 a month to qualified buyers \$799

Quasar 25" Console

- Quasar dependability
- Dynacolor
- Illuminated dial numbers
- Picture adjustment & sharpness control
- Easy roll casters & more.

ZERO DOWN \$12 a month to qualified buyers \$439

DON'T STAY HOME WITHOUT IT!!!

Discount Video video club
OFFER EXPIRES Feb. 15, 1985

Get 2 FREE Movie Rentals when you join the club. Just bring in this ad for details.

Now Save 50% on the most valuable accessory for your home Video Recorder

VIDEO CLUB MEMBERSHIP \$25.00*
Reg. \$50.00

Quasar T-120 BLANK TAPE \$5.49* with this ad

10% OFF Any TV or VCR Repair with this ad

GET A FREE* MOVIE RENTAL When you rent another movie with this ad DISCOUNT VIDEO

Discount Video
MILFORD Highland Ave., Prospect Hill Shopping Ct. 684-0273
*Expires 2-15-85

Orin Jewelers INC
Since 1933

Don't Forget Valentine's Day
Thursday, February 14

Gift Ideas for your Special Valentine
See our Fabulous Selection of
Heart Shape Design Jewelry
At a Special Savings of
14% OFF
thru Valentine's Day February 14

Watches
Pearls
Pendants
Wedding Rings
Loose Diamonds

Rings
Earrings
Bracelets
Broaches
Gold Chains

NORTHVILLE
101 East Main Street at Center
349-6940

GARDEN CITY
29317 Ford Road at Middlebelt
422-7030



Herman's
WORLD OF SPORTING GOODS

PRESIDENT'S SALE

Sale now through Feb. 18, 1985



We Welcome The American Express Card.

warmups

NIKE Men's or
HEAD Women's Warmups

49⁹⁹
reg. and orig.
59.99 to 81.99

Men's full zip jacket and
matching pants with leg
openings. Women's style
in soft, warm fleece!

SUPER VALUE! PUMA Glide
Men's Leather Court Shoes

21⁹⁹
orig. 34.99

Save
\$13



WILSON 1200GE
Metal Drivers
29⁹⁹
orig. \$60
Investment cast;
perimeter weighted.



Save
\$30

DUNLOP, WILSON
Pro Golf Balls
11⁹⁹
doz.
to \$24 in pro shops
Dunlop DDH II or
Wilson Pro Staff.



BILLARD 110 lb.
Steel Barbell Set
Solid steel bar;
steel collars;
2 dumbbell bars.
49⁹⁹
reg. 69.99



we are
sports

DUNLOP
Yellow
Tennis Balls
1⁸⁸

Slightly blemished.



33% OFF

reg. and orig. prices

Selected Tennis Frames:
WILSON, PRINCE, HEAD, DONNAY,
PRO KENNEX and more!

Choose from assorted head sizes.
All frames come with covers.
Save big while present
in-store quantities last!

Save
30%

WINNING WAYS Men's
Action Pants

9⁹⁹
reg. 19.99

100% cotton pull-on;
reinforced pockets.

Save
50%

NIKE, PUMA Men's
Football Jerseys

7⁹⁹ TO 9⁹⁹
orig. 13.99
to 14.99

Durable and easy
care poly/cotton.

NIKE
STRAIGHT
FLYWEIGHT
Exercise Bike
99⁹⁹
reg. 129.99

Weighted flywheel
with tension band
Cassette complete
with speedometer,
odometer and time
New! Save \$30!

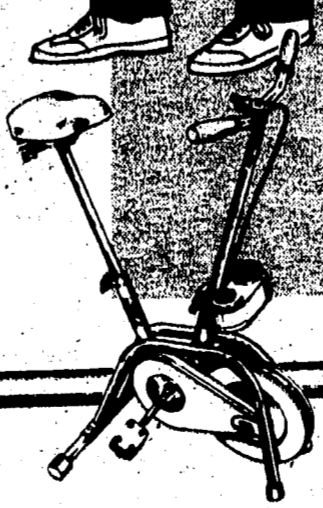

20% OFF

ALL BOWLING BALLS
BOWLING BAGS &
BOWLING BRICKS

Free measuring,
drilling and
finishing
with purchase
of any ball!



ADVERTISING SUPPLEMENT

HERMAN'S GOLF AND RACKET SUPER SALE...

Graphite construction for extra power when you need it.

Graphite glass composite combines stiffness and flex.

Aluminum construction. Large hitting area.

210 Denier nylon; foam backing.

*Cover included. Stringing at additional cost.

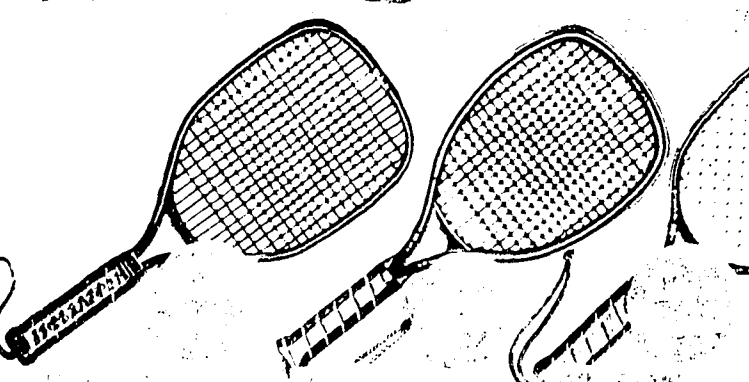
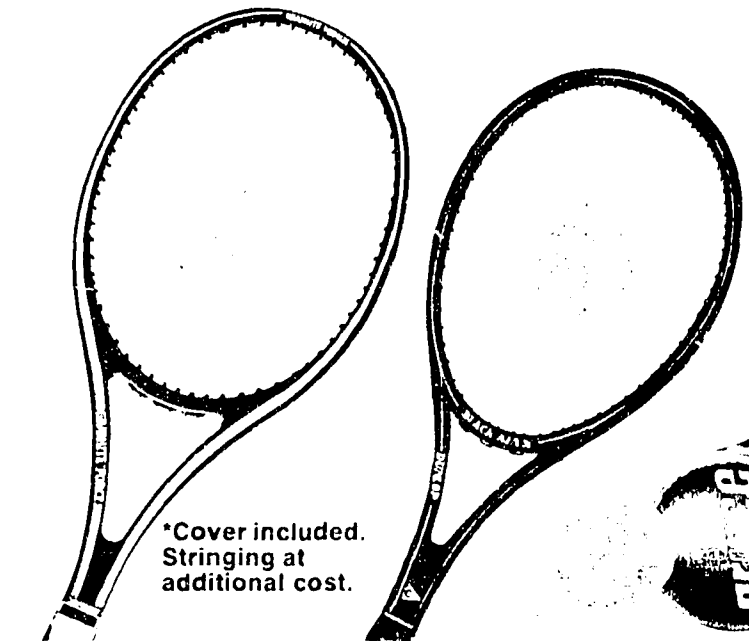

Quadriform head shape.

Strong and lightweight.

Comes with cover.

Graphite comp. Thermal cover.

FENN RB-960 Racquetballs \$1.99

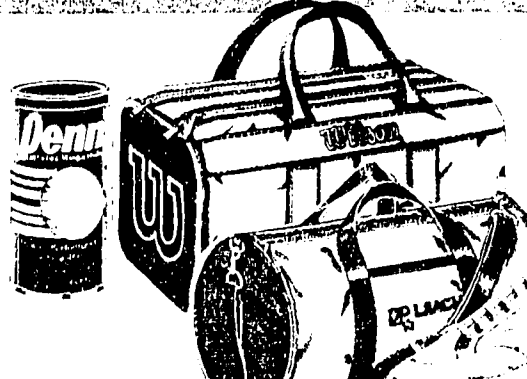

20% OFF Entire Stock of Racquetball Bags

Technology "huff face" Racquetball shoes \$19.99

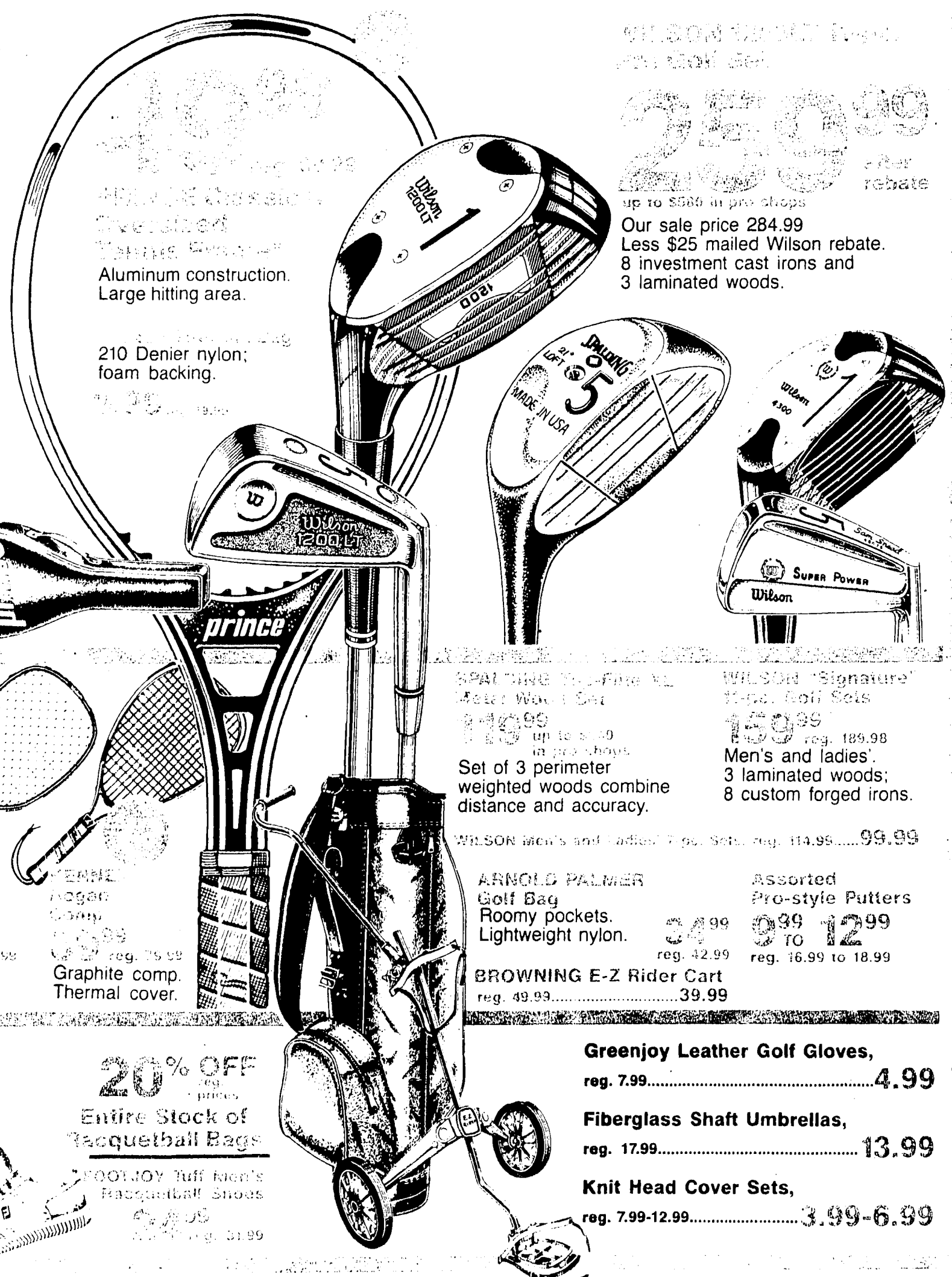

Wilson Golf Club Set
Our sale price 284.99
Less \$25 mailed Wilson rebate.
8 investment cast irons and 3 laminated woods.

Set of 3 perimeter weighted woods combine distance and accuracy.

Wilson men's and ladies' Golf Sets, reg. 114.95... 99.99

ARNOLD PALMER Golf Bag, Roomy pockets. Lightweight nylon. \$74.99 reg. 42.99

BROWNING E-Z Rider Cart reg. 49.99... 39.99

Greenjoy Leather Golf Gloves, reg. 7.99... 4.99

Fiberglass Shaft Umbrellas, reg. 17.99... 13.99

Knit Head Cover Sets, reg. 7.99-12.99... 3.99-6.99

RUN, JUMP, CATCH, SAVE!

Men's and Women's Fleece Sweats **20% OFF**

Crew Tops or Pants, reg. 10.99... 8.79
Pullover Hooded Tops, reg. 13.99... 11.19
Zip-Hooded Tops, reg. 16.99... 13.59
Shorts, reg. 8.99... 7.19
Women's Short-Sleeve Tops, reg. 8.99... 7.19

KIDS' SWEATS

Crew Tops... 6.99
Pants... 6.99
Pullover Hood Top... 9.99
Zip Hood Top... 10.99

30% NIKI Fashion Fleecewear

Assorted separates in fashion colors to mix 'n match. Great buys!
Men's Crew Top, orig. 27.99... 18.99
Men's Vest, orig. 27.99... 18.99
Men's Pants, orig. 25.99... 17.99
Women's Jacket, orig. 29.99... 19.99
Women's Vest, orig. 24.99... 15.99
Women's Pants, orig. 26.99... 17.99



PRESIDENT'S

Purchase a Wilson A2000 Baseball Glove and receive a rebate of \$25. Mailed direct from Wilson.

WILSON A2000 Fielder's Glove \$74.99
Choose from assorted models of our best selling gloves!

RAWLINGS Dove Windale Baseball Glove \$39.99
Large pocket is ideal for baseball and softball. Finest quality leather.

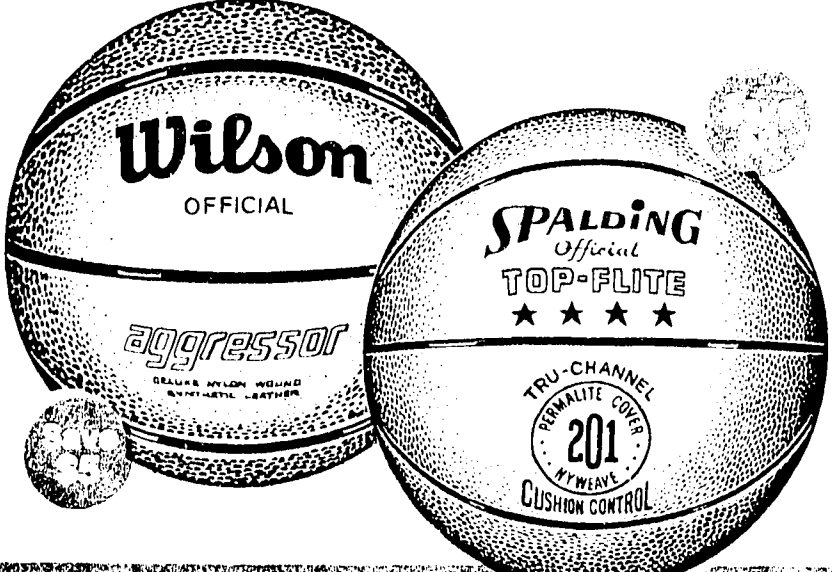

WILSON Aggressor Basketball \$24.99
Durable synthetic cover is ideal for all courts. Official size and weight.

SPALDING Top-Flite Basketball \$17.99
Rugged cover designed for great performance on indoor and outdoor courts. Super buy!

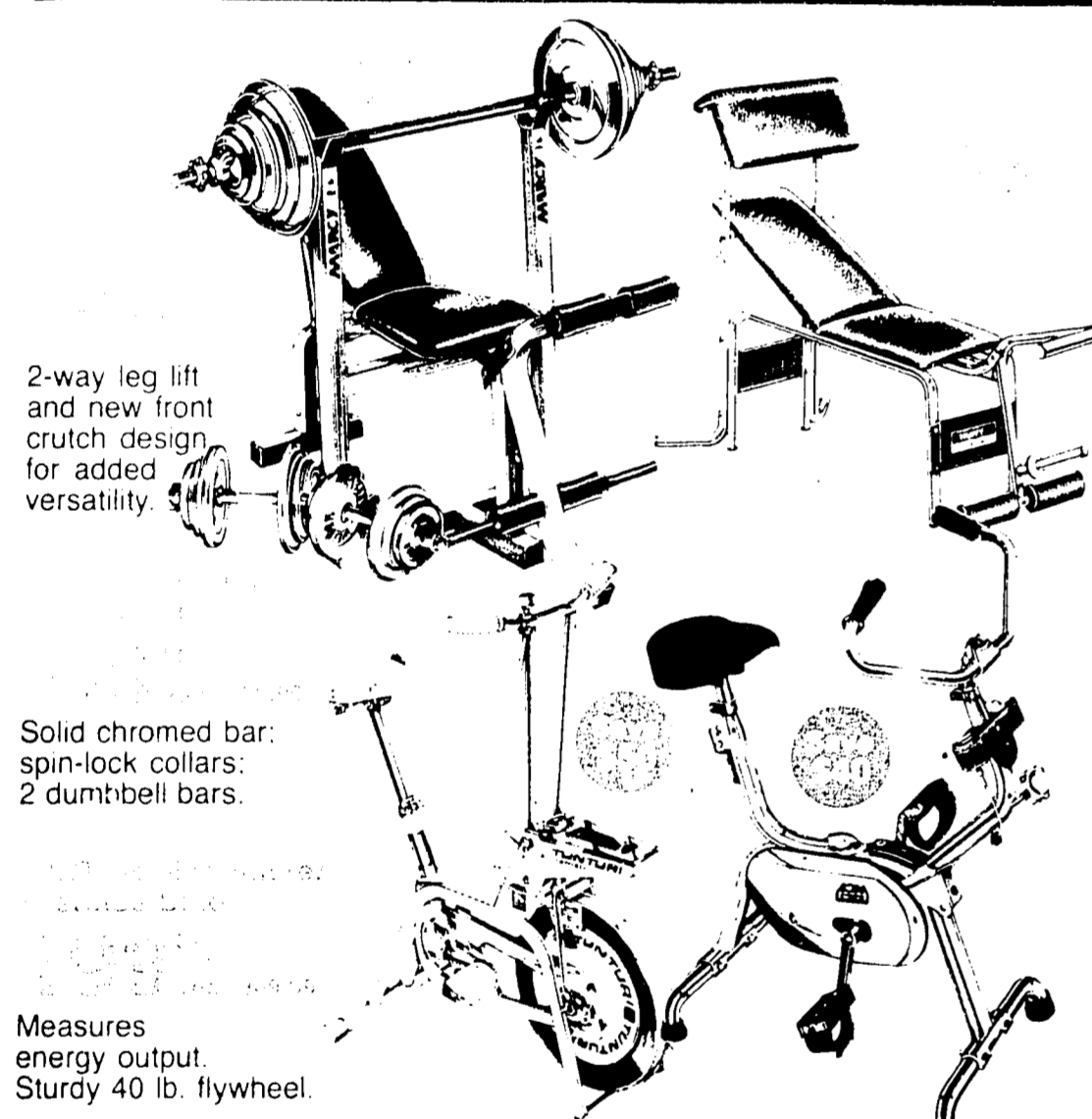

2-way leg lift and new front crutch design for added versatility.

Solid chromed bar; spin-lock collars; 2 dumbbell bars.

Measures energy output. Sturdy 40 lb. flywheel.

Operates quietly and smoothly. Adjustable tension.

PRECOR 612 Dumbbell Set \$99 reg. 255.99
Smooth flow; adjustable hydraulic tension.

WEIDER Super Armblaster or GENERATION II Solid Curl Bar

Curl bar with fixed inside collars. Armblaster locks arms in place for curling. YOUR CHOICE

19⁹⁹ reg. 24.99

Create a customized weight bench with these components:

- Incline Bench, reg. 49.99.....42.99
- Leg Lift, reg. 34.99.....29.99
- Arm Curl, reg. 19.99.....15.99
- All 3 pieces, reg. 104.97.....88.97

BILLARD 115 lb. Vinyl Weight Set with solid steel bar and 2 dumbbell bars
27⁹⁹ reg. 32.95 (not shown)

MCA 2-way Exercise Bike
159⁹⁹ reg. 199.99
Pedal and row separately or simultaneously.

AMF "Heavy Hands" Aerobic Handles
15⁹⁹ set of two 1 lb. weights (Others available) reg. 19.99

GENERATION II 6 lb. Dumbbell Set
5⁹⁹ reg. 8.99

GENERATION II 20 lb. Dumbbell Set
14⁹⁹ reg. 19.99

K.R. INDUSTRIES 2 x 6 Exercise Mat
9⁹⁹ reg. 13.99

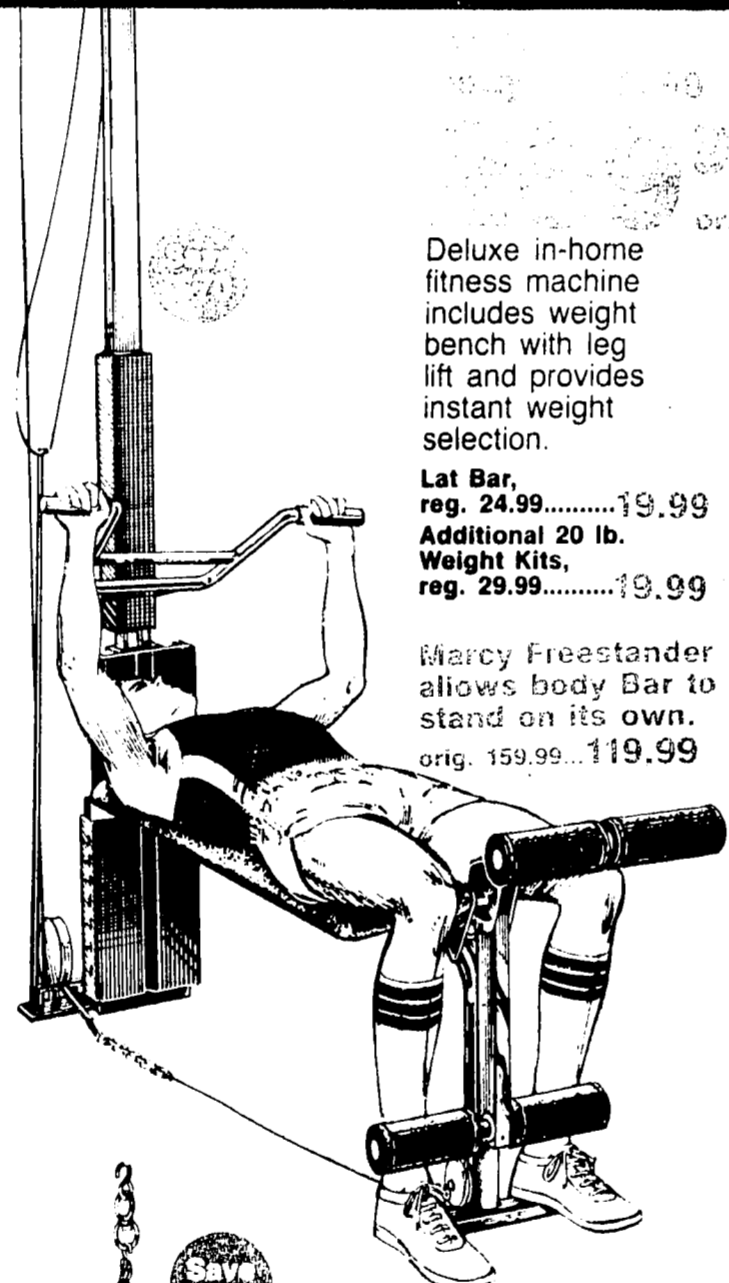

Deluxe in-home fitness machine includes weight bench with leg lift and provides instant weight selection.

Lat Bar, reg. 24.99.....19.99
Additional 20 lb. Weight Kits, reg. 29.99.....19.99

Marcy Freestander allows body bar to stand on its own. orig. 159.99...119.99

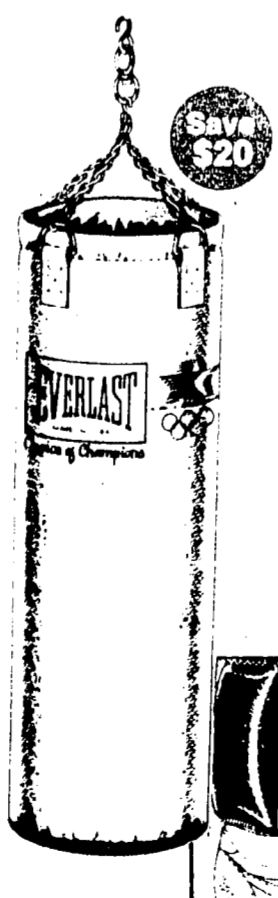

EVERLAST 70 lb. Training Bag
49⁹⁹ reg. 69.99
Rugged canvas; double sewn seams; chain included.

EVERLAST 5 lb. Ankle Weight Set
7⁹⁹ reg. 10.99
10 lb. Set, reg. 16.99.....12.99

NIKE and PUMA Men's and Women's Selected Warmups

39⁹⁹

reg. 49.99 to 53.99
Men's fleece or acrylic styles, some with hooded jackets. Matching pants. Women's assorted jackets and coordinating pants. Poly/cotton blends. Assorted fashion colors.



Save \$10 to \$14

HERMAN'S Men's Fleece Warmup

19⁹⁹

reg. 34.99
Durable and easy care acrylic. Full zip jacket, matching pants.



ALL WOMEN'S RUNNING SEPARATES
25% TO 50% OFF
Great savings off our regular low prices on tops and bottoms. While quantities last!

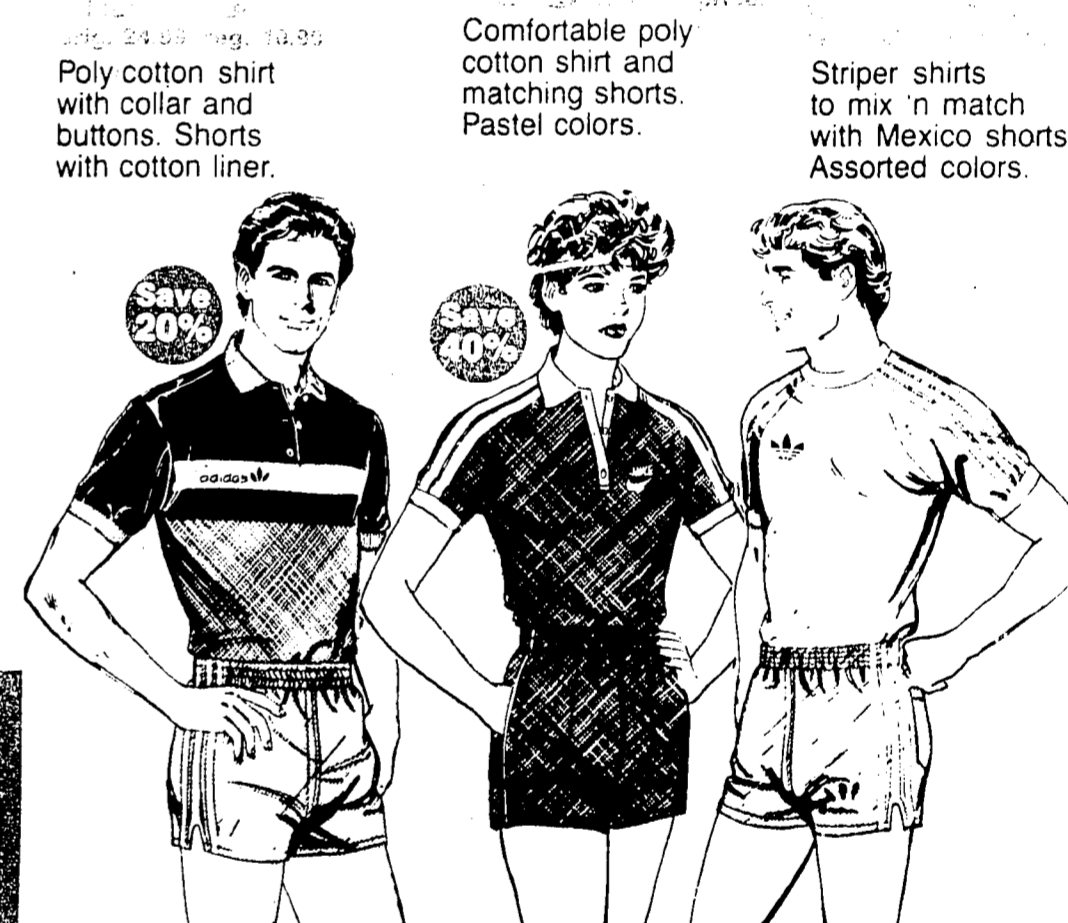

30% TO 40% OFF FOR KIDS

NIKE Women's Nylon Wind Separates

Jacket
27⁹⁹ reg. 39.99

Pants
14⁹⁹ reg. 21.99

Jackets and pants in spring fashion colors.

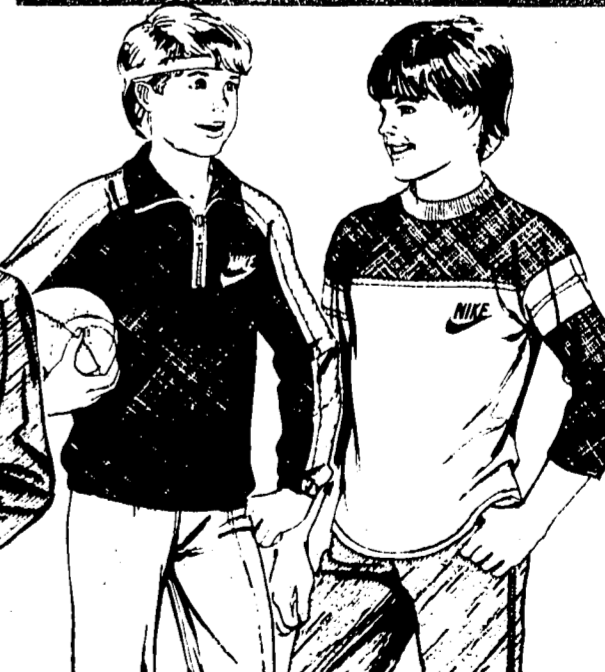

NIKE Sport Junior Wind Jacket
Lightweight nylon; half zip front. 14⁹⁹ orig. 21.99

NIKE Tackle Junior Active Shirt
Poly/cotton in assorted colors. 6⁹⁹ orig. 13.99

PLUS GREAT EVERYDAY LOW PRICES ON OTHER GYMWEAR, ACTIONWEAR, WARMUPS AND SWEATS. CHOOSE FROM NIKE, ADIDAS, PUMA AND MORE. SHOP AND COMPARE, THEN SAVE AT HERMAN'S!

HERMAN'S WORLD OF SPORTING GOODS

A VERY HEALTHY OUTLOOK: EXERCISE SAVINGS FOR YOU!

PRESIDENT'S SALE

HERMAN'S GET THE BEST OF THE OUTDOORS...

149.99 Sleeps 8. Floor throughout.

119.99 Sleeps 4. Compact. Shock corded poles.

119.99 Reg. 137.99 Sale 107.99 Less \$8 mailed Coleman rebate.

59.99 reg. 79.99 LIGHTWEIGHT. SHOCK corded fiberglass poles.

30% OFF reg. prices
SHAKESPEARE, GARCIA, DAIWA, ZEBCO and RYOBI Spinning Reels
Choose from selected models.
SHAKESPEARE 030,040, or 050. **14.99** reg. 21.99

30% OFF reg. prices
GARCIA, RYOBI, ZEBCO Selected Rod Reel Combos
Choose from assorted spinning and baitcast reels plus matching rods and save big off our usual low prices!

30% OFF RODS reg. prices
FENWICK, GARCIA, DAIWA, BERKLEY, BROWNING and more
Variety of lengths and actions from the finest names in fishing! Choose from selected models. Hurry and save BIG!

Save \$5 Fishing Vest. **19.99** reg. 24.99
Many pockets. Handy creel. **11.99** reg. 16.99

25% OFF reg. and orig. prices
Entire Stock of Sleeping Bags, Back Packs, Day Packs and Duffles
Wenzel, North Face, Jansport, Coleman, Wilderness Experience and more!

19.99 COLEMAN 28-qt. Ice Chest
Reg. 32.99 Sale 22.99 Less \$3 mailed rebate.
34-qt. Ice Chest after mailed rebate. **13.99**

25% OFF reg. prices
Entire Stock of Bushnell Binoculars

20% OFF reg. prices
Entire Stock of Victorinox Swiss Army Knives

SUPER SHOES FOR SPORTS...

PRESIDENT'S SALE

RUNNING

SAVE 30%
NEW BALANCE 460 Running Shoes
34.99 orig. 49.99
Our lowest price ever on this great performance running shoe for men and women.

NIKE Finale Men's and Women's Running Shoes
19.99 reg. 24.99
Lightweight nylon uppers; padding for extra comfort; all surface sole.

SAUCONY America Men's and Women's Running Shoes
37.99 reg. 44.99
Molded EVA wedge provides added cushioning. Extended heel counter.

BASKETBALL

CONVERSE Men's Starion Mid
42.99 reg. 49.99
¾ height full grain leather uppers; Velcro® closure for top support.

NIKE Men's Sky Force Hi
45.99 reg. 52.99
Supportive leather uppers; all-court rubber sole.

NIKE Men's Meadow Supreme
24.99 reg. 34.99
Durable mesh and leather uppers; rugged hobnail sole.

PONY Men's Silver Ace II
24.99 orig. 35.99
All leather uppers; comfortable Velcro® closure; hobnail sole.

CONVERSE Jimmy Connors or Chris Evert
29.99 reg. 39.99
Durable all leather uppers; extensive padding; rubber sole.

AEROBIC

REEBOK Women's Aerobic Shoes
Soft, supple. Cushioned for comfort. Rugged, non-slip sole.
29.99 reg. 34.99

FINEST QUALITY LEATHER UPPERS!

NIKE Vulcan Leather Sport Shoes
Velcro® straps for great fit. Stitched-on sole.
19.90 orig. 29.99

YOUR CHOICE **6.99** reg. 7.99
SOCKSMITH Men's and Boys' 6-pr. Pack of Tube Socks
SOCKSMITH Men's 6-pr. Pack of Crew Socks.

20% TO 45% OFF SKIWEAR AND SKI EQUIPMENT!

20% TO 45% OFF orig. prices

EVERY SKI IN STOCK
Recreational, sport, competition.
Beginning to advanced skiers.

ROSSIGNOL
HEAD 
DYNASTAR
FISCHER

20% TO 25% OFF orig. prices

EVERY SKI BOOT IN STOCK
Nordica, Raichle and more. Models
for all levels of skiing ability.

20% TO 40% OFF orig. prices

**ENTIRE STOCK OF
DOWNHILL SKI BINDINGS**
Salomon, Tyrolia, Look.
For beginning to advanced skiers.



20% TO 40% OFF reg. and orig. prices

SKIWEAR...

ENTIRE STOCK OF
MEN'S AND WOMEN'S
• PARKAS • BIB PANTS
• STRETCH PANTS • VESTS
• SKI SWEATERS

WHITE STAG, GERRY, PROFILE, TYROLIA
and other famous makers. Choose from
selected styles while quantities last!

30% TO 40% OFF orig. prices

**ENTIRE STOCK OF
RUGGED DOWN OUTERWEAR!**
• PARKAS • JACKETS • VESTS
Assorted styles and colors.

20% TO 40% OFF orig. sold sep. prices

EVERY X-COUNTRY PACKAGE
Jarvinen, Trak, Fischer, Rossignol.
All packages include skis, boots,
bindings and cross country poles.

 **Herman's**
WORLD OF SPORTING GOODS

PRESIDENT'S

★★★★★★★★★★★★★★★★★★★★

SALE 

- BIRMINGHAM: 13 Mile & Southfield Rds.
- TROY: 268 John R. Road
- SOUTHFIELD: Northland Shopping Center
- HARPER WOODS: Eastland Center
- STERLING HEIGHTS: Lakeside Mall
- FLINT: Genesee Valley Mall
- DEARBORN: Fairlane Town Center
- NOVI: Twelve Oaks Mall
- LANSING: Lansing Mall
- ANN ARBOR: Briarwood Mall

VISIT OUR NEW STORE
13 Mile and Southfield Rds.
Corners Shopping Center
BIRMINGHAM

NOTE All items may
not be available at all
stores. Intermediate
mark-downs may have
been taken on items
bearing "orig." prices.