

Private funds may relieve center-city traffic

By BRUCE J. MARTIN
 staff writer

Plans for a privately-financed system of road improvements have been resurrected for Section 15, the square mile of land immediately west of Twelve Oaks Mall.

The failure of the proposed convention center to materialize has resulted in a scaling-down of the once-proposed road system in that district. But city officials and Section 15 property owners are optimistic the roadwork and water-sewage infrastructure improvements will substan-

tially improve traffic flow in the central city area while opening up new areas for development — and the roadwork could be completed by late fall.

"This could ease the traffic dilemma related to Twelve Oaks Mall, West Oaks I and II by giving us a rear entrance to West Oaks and reducing (traffic) demand on Twelve Mile," said Novi City Manager Edward Kriewall. "I think this is a very good step we should take for the community."

Novi City Council on Monday approved a new special assessment district for nine property owners whose land will be af-

ected by a proposed \$2.8 million in public improvements, with payments spread over a 15-year time span.

The improvement of most concern to city residents is the network of new roads in the heavily congested area. The planned improvements will allow the westbound I-96 ramp at Novi Road to be re-opened and allow the access road winding south of the Sheraton Oaks hotel to intersect with a north-south road running along the western edge of the West Oaks I and II shopping centers.

The effectiveness of the new north-south

link to Twelve Mile may be enhanced by the completion of the proposed Westbrooke Place development at Beck Road and Grand River. The accompanying improvements to the I-96-Beck interchange will offer drivers an efficient alternative to get to the regional shopping districts in the central city area.

In addition to the north-south road, a new east-west drive leading into the planned West Oaks II development will be built opposite (west of) the northernmost Novi Road entrance to Twelve Oaks Mall.

Section 15 interests represented chiefly by Gerald Abel of Sheraton Oaks and

Michael Ward of Ramco-Gerstenson, developer of the West Oaks projects, appeared to be confident the group of property owners would support the new special assessment district.

The new special assessment agreement was a difficult one to forge. Different property owners asked for a variety of credits and payment terms to finance the district.

If the contract SAD is agreed upon quickly, city officials believe the project will be ready to bid within four weeks, bond backing could be secured in time to fund construction in July, and all roadwork could be completed by the end of November.



Police remembered

Sunday was Police Memorial Day in the City of Novi, and ceremonies at city hall honoring police officers who died in the line of duty attracted a strong turnout. Above, Livonia SWAT Of-

ficer Ron Proudlock salutes his fallen comrades in Sunday morning observances. A photostory of the day's events appears inside on page 7A.

Novi News/RICK SMITH

Iron Workers' new base: Novi

Headquarters for Michigan's largest ironworkers union will move to an attractively-designed new meeting hall-credit union-office complex in Novi, probably by the end of 1986.

The union's new home base will be a six-acre industrially-zoned site located east of the foot of Trans-X Drive, off Novi Road between Ten Mile and Grand River. The Novi Planning Commission last Wednesday gave its approval to site plans for the project, designed by architect Lee Mamola.

"It's a commendable plan," observed Commissioner Gary Phillips. "I like to see a project like this; I think it's a good thing for Novi to have."

The project likely will be a relief to neighboring residents of Beacon Hill Apartments and Meadowbrook Glens subdivision to the east, since under the site's current zoning, a much larger, less attractive industrial building could be located closer to the residential areas.

"We were looking for property that suited our needs," said Iron Workers Union Vice-President Harold Cooper, explaining that the union's current base on Seven Mile at Greenfield Road had grown unsatisfactory.

The union covers a 34-county area and has 2,300 members, Cooper said. The new Novi building site, he added, would become the per-

manent home to the seven-person union administration and the union's credit union.

The complex itself will be built in two phases. The first phase includes the credit union office, office space and the 576-seat meeting area (private club/lodge hall) totalling 16,800 square feet. A separate office building of 5,620 square feet will be built in the second phase of construction.

Architectural plans submitted by Mamola show the exterior of the buildings will be of tinted glass and steel panels similar to those of the Novi Hilton, but accented with colored horizontal patterns.

Planners back office project

By BRUCE J. MARTIN
 staff writer

The developers of Westbrooke Place got a shot in the arm from the Novi Planning Commission and planning staff last Wednesday.

Westbrooke Place is the proposed multi-million dollar office-hotel-recreation development on a 72-acre parcel near Beck Road and Grand River. Its developers, Joseph Gerak and Gloria Gelstein, have asked for a rezoning of the now-residentially zoned land (currently the site of Bob-O-Link Golf course), but have run across several difficulties. Existing zoning and the city's Master Plan (guide to long-range development) specify the property's continued use as a golf course.

In order to proceed with plans, the developers have requested the property be rezoned to OSC (office-service center). The OSC classification permits buildings up to five stories in height, including offices (Gerak and Gelstein are proposing three-story structures), hotels, and accessory buildings and uses, including commercial.

Gerak and Gelstein have stated their project would consist principally of offices, a hotel, a large-scale recreation-sports facility, and

accessory commercial uses. Eventually, they plan to integrate a nine-hole golf course and probably condominium housing on property southwest of Grand River and Beck.

Last week, Novi City Council listened to the proposal and returned it to the commission for consideration in light of several concerns council members raised about the project. Last Wednesday, commission chairperson Ernest Aruffo sounded out planning staff on the concerns one by one. After hearing the consultants' responses, commissioners unanimously recommended the rezoning be approved.

Briefly stated, the questions raised by council were as follows:

□ *What will be Westbrooke Place's impact on Grand River Avenue development, now mostly light-industrial but possibly more suited to offices?*

According to Novi Planning Consultant Brandon Rogers, "If it goes in, it's going to be a catalyst for development on west Grand River from Beck to Taft and from Taft to the Town Center. Much of that land is presently I-1 (light industrial). If

Continued on 9

School hopefuls to meet, debate

Two candidates' nights are scheduled next week for Novi residents interested in hearing school board candidates address the issues.

The League of Women Voters will host a candidates' night at 7:30 p.m. Monday, May 19, at Orchard Hills Elementary School. The forum will be taped by Metrovision.

On Thursday, May 22, the Meadowbrook Glens Homeowners Association will host the candidates at 8 p.m. at Orchard Hills.

Eight candidates are vying for three seats in the June 9 election.

School board incumbent Robert Schram and newcomer Sandra Thornton are seeking election to the full four-year board seat.

Incumbent Ray Byers is being challenged in his bid for the two-year term by John Balagna.

The most contested race is for the one-year seat currently held by newly-appointed trustee Stephen Hitchcock. Hitchcock is being challenged in his bid for the one-year post by Patricia Konedra, Brian Fannon and Jon Dostal.

The candidates' forums are open to the public.



Over
120
 Garage Sale Ads
 In This Week's
 GREEN SHEET!

GREEN SHEET
 Action Ads
 Get Results
 348-3024

BUSINESS 1B
 CLASSIFIEDS 5B
 COMMUNITY NOTES 4C
 EDITORIALS 10A
 ENGAGEMENTS 4C
 LETTERS 11A
 LIVING 1C
 NEARBY 9A
 NOVI BRIEFS 6A
 NOVI CHAMBER 4A
 NOVI HIGHLIGHTS 2C
 OBITUARIES 9A
 PEOPLE 4C
 POLICE BLOTTER 4A
 REC BRIEFS 6C
 SPORTS 5C

EDITORIAL 349-1700
 ADVERTISING 349-1700
 CLASSIFIEDS 348-3024
 DELIVERY 349-3627

GOP candidates huddle at Hilton



Novi News/JERRY ZOLYNSKY

Born-again Republican William Lucas was unavailable, but GOP gubernatorial candidates Richard Chrysler, Colleen Engler, John Lauve and Daniel Murphy attended Monday's debate at the Novi Hilton.

By PHILIP JEROME
 managing editor

Governor James Blanchard came under heavy fire for a variety of alleged transgressions as four of the five Republican candidates for governor debated the issues at the Novi Hilton Monday morning.

Wayne County Executive Bill Lucas was the only Republican gubernatorial candidate who did not show for the debate sponsored by the Novi Chamber of Commerce's Political Action Committee (PAC).

John Lauve, a quality control engineer with General Motors and leader of the unsuccessful Recall Blanchard movement, rapped the governor for purchasing a \$1.6 million helicopter which he called "Tax Wolf" and noted that Michigan still ranks last in the nation as a place to do business, according to the Alexander Grant Report.

Continued on 8

Michigan Week activities set

Whether you call it "The Great Lakes State" or "The Cornbelt State," Michigan residents have plenty of reasons to be proud — and they will take time to celebrate those reasons next week during Michigan Week (May 17-24).

"Michigan Week is a special time each spring to focus attention on Michigan and Novi's resources, heritage and boundless opportunities," said Kathy Crawford, chairman of Novi's Michigan Week festivities.

"It's an occasion for Michiganders to increase their knowledge and appreciation of all that makes Novi and Michigan so great."

The big event, as far as city officials are concerned, will be Mayor's Exchange Day next Monday (May 19). This year Novi has been paired with the City of Portage, a community with a population of 38,157 located near Kalamazoo.

Mayor Patricia Karevich, Council Member Edward Lettinger and Assistant City Manager Craig Klaver will travel to Portage Sunday night and be entertained by officials in that

city. Portage Mayor Charles Marchek, Council Member Ann Hinga and Assistant City Manager Michael Collins will travel to Novi the same evening.

Activities for the Portage dignitaries include dinner at the Country Epicure on Sunday night, a tour of Guardian Photo on Monday morning and tours of the city's police, fire and DPW facilities Monday afternoon.

Here's a list of other Michigan Week activities planned in Novi:

TUESDAY, MAY 20 (Senior Citizens/Government Day): Seniors from the OLHSA Center and Novi's Parks and Recreation program will hold an ice cream social at Faith Community United Presbyterian Church from 1-3 p.m.

WEDNESDAY, MAY 21 (Commerce Day): The Novi Chamber of Commerce is sponsoring a luncheon and tour of the Mohawk Liquor facility. The activity costs \$10 per person and reservations must be made with Chamber Secretary Elaine Cook at 349-3743 by May 19.

The Todd Corporation, an industrial laundry, also will offer a tour. Call Jerry Isengerg at 349-3743 for details.

The Novi Schools' Food Service Department is sponsoring "Parents

Novi Briefs

MAYOR'S EXCHANGE DAY could take on a "glitzy" look in the future if Mayor Patricia Karevich has her way.

With tongue planted firmly in cheek, Karevich announced Monday that she's working on plans for Novi to exchange mayors with Carmel, California, in 1987.

Because such an exchange would entail cross-country travel expenses for the Novi mayor and taxpayers, Karevich said she would volunteer to remain in Novi and personally greet Carmel's new mayor — Clint Eastwood.

SMALL BUSINESS WEEK starts Sunday, May 18. Novi Mayor Patricia Karevich and the Novi City Council have declared.

A proclamation honoring small businesses for their contributions to the American economy and free enterprise system was approved by the city council Monday.

SCHOOL DISTRICT BUDGET WORKSHOPS: The Novi school board has announced its schedule of meetings for discussing the 1986-87 budget. All sessions are open to the public and citizens are encouraged to attend and offer their input.

The preliminary budget is expected to be discussed at the board's regular meeting May 15. A special board meeting for budget discussion is scheduled May 29 at 7:30 p.m. in the Administrative Services Building. A budget hearing will be held at the regular board meeting June 5. Final budget adoption is scheduled at the board's regular meeting June 19.

NOVI'S MEMORIAL DAY PARADE has been set for 10 a.m. to 11:30 a.m. Monday, May 26. The proposed route will begin at Mohawk Drive near Novi Road and I-96 and continue south to Ten Mile, then west to Novi City Hall.

Planners of the parade this year are anticipating greater participation than in previous years.

ROUGE RESCUE '86 DAY is set for June 7. The day-long volunteer project, intended to bring attention to efforts to restore the Rouge River's ecosystem, will be followed by a celebration party this year.

PROCEEDS OF \$800 were raised for the Novi Emergency Food Program thanks to the recent wine and cheese party hosted by Country Place Condominiums. Along with the donations of the sippers and nibblers, St. Julian Winery donated wine, Country Place donated facilities and \$100, and the Country Place Women's Club donated hors d'oeuvres.

PLANS FOR A ONE-STORY office/industrial/warehouse building were approved by Novi planning commissioners last Wednesday. The 14,882-square-foot structure will be built on Vincent Drive in the Vincent Industrial Park.

A WAREHOUSE/OFFICE BUILDING of 44,000 square feet in area will likely be built on a deep, narrow 2.9-acre land parcel just east of Cervi's White House manor at Novi Road and Nine Mile.

Site plans, approved unanimously by the city planning commission last Wednesday, will include a six-foot brick wall along the west side. Offices will be located on the south part of the building facing Nine Mile, with storage facilities in the rear (north).

The north lot line will front the planned Saddle Creek apartment complex, and the city will require screening of that border by either Saddle Creek owners or by the warehouse/office site owner William Damavolites — whoever obtains final site plan approval last.



Novi News/PHILIP JEROME

Police Memorial Day 1986

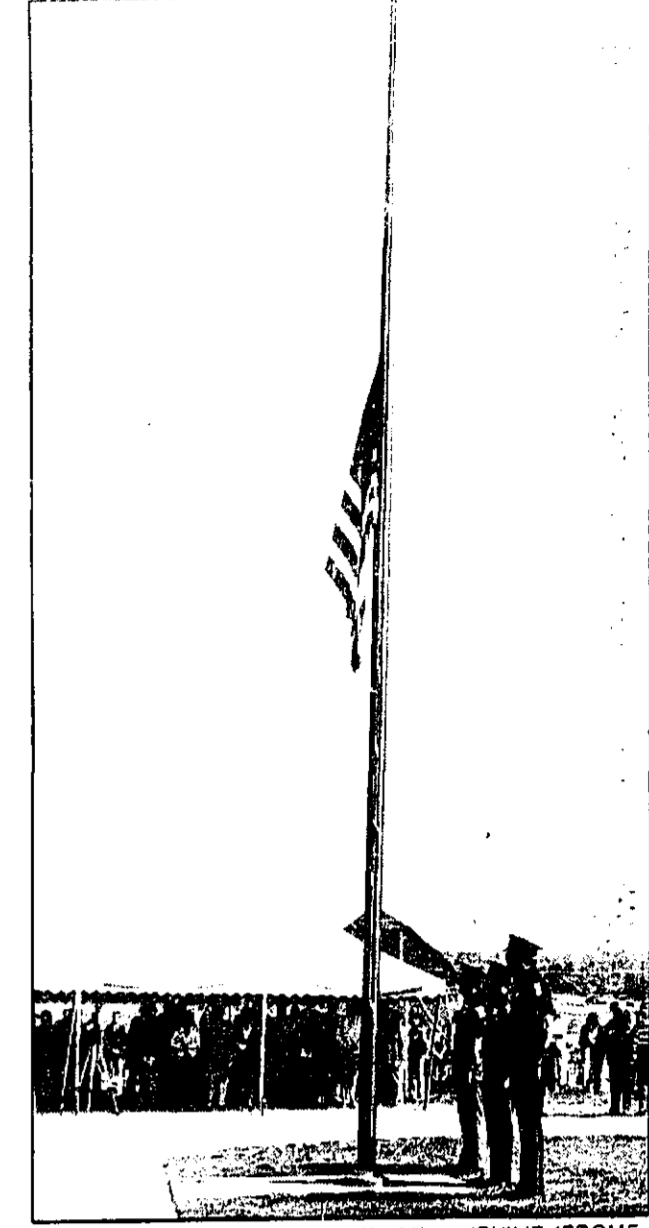

Novi News/PHILIP JEROME

Madonna to host peace symposium

The second annual "Peace in the Nuclear Age" Symposium will be held at the Peace Resource Center on the Madonna College campus in Livonia on Thursday, May 15, at 7 p.m.

The event is designed to bring speakers of local and national renown together to talk about such issues as the strategic implications of Star Wars, the influence of big business on military procurement decisions and such tactics of resistance as the world peace tax fund, civil disobedience and non-violent civilian-based defense.

The evening also will include a children's peace parade of students' art and writings on peace in connection with the Michigan Peace Child Project.

The symposium will begin at 7 p.m. with a keynote address by Clara Vincent of Livonia, a longtime peace activist whose involvement dates back to the 1930s. She became a member of the Women's International League for Peace and

Freedom in 1930 and attended the second international Women's Peace Conference in Warsaw in 1950.

Following the keynote address will be three workshops running simultaneously at 8:30 p.m.

Speakers for the "Star Wars" workshop will be Dr. Dan Axelrod and Captain James Bush. Axelrod is co-author of the soon-to-be released "To Win a Nuclear War: The Pentagon's Secret Strategy." The book demonstrates how U.S. policy makers in over 40 years since the invention of the bomb have always aimed to win a nuclear war.

Bush is a retired U.S. Naval officer who formally served in several command level positions, including nuclear armed vessels.

Speakers for the "Economics" workshop will be John Boies and Michael Oden. Boies, a doctoral candidate at the University of Michigan's Department of Sociology, is widely published in the field, including works on the relationship between U.S.

defense contractors and military policy. Oden has done extensive original research into the effects of defense spending on the economy.

Speakers for the "Resistance" workshop will be Reverend Peter Dougherty, Frances Eliot and Dr. John McCartney. Dougherty is a widely recognized expert on non-violent conflict resolution and civil disobedience. He is a founder/member of Christian Faith & Resistance Community which leads protests at Williams International in Walled Lake. Eliot, Ann Arbor coordinator of the World Peace Tax Fund, lectures extensively on tax resistance as an alternative to taxes for war.

McCartney is director of the Non-Violent Action for National Defense Institute at Mercy College.

The Peace Resource Center is a local organization dedicated to providing educational opportunities and fostering citizen activism around the issues of nuclear disarmament, peace and social justice. For more information call 464-7766.



Novi News/RICK SMITH



Novi News/PHILIP JEROME

CITY OF NOVI NOTICE
SUMMARY AVAILABLE OF FISCAL YEAR 1986-87 BUDGET

All interested persons are hereby notified that a summary of the Fiscal Year 1986-87 Budget of the City of Novi including intended uses of Federal Revenue Sharing Funds is available for public inspection. The Budget Summary and documentation necessary to support the summary are available at the office of the Finance Director, 45225 W. Ten Mile Road, Novi, Michigan, from 8:00 a.m. to 5:00 p.m. Prevaling Eastern Time, Monday thru Friday.

Geraldine Stipp, City Clerk
(5-14-86 NR, NN)

NOTICE OF SPECIAL ASSESSMENT HEARING
CITY OF NOVI
COUNTY OF OAKLAND, MICHIGAN

TAKE NOTICE that the City Council of the City of Novi, Oakland County, Michigan has determined it to be necessary to make the following described public improvement in the City of Novi:

Construction of approximately 1,230 lineal feet of eight (8) inch Sanitary Sewer together with associated manholes and house leads.

The City Council has determined that all of the cost of the above described public improvement shall be assessed against the following described property abutting the above described improvement.

22-27-200-006 22-27-200-007
22-27-200-008 22-27-200-009

NOTICE OF SPECIAL ASSESSMENT HEARING
CITY OF NOVI
COUNTY OF OAKLAND, MICHIGAN

TAKE NOTICE that the City Council of the City of Novi, Oakland County, Michigan has determined it to be necessary to make the following described public improvement in the City of Novi:

Construction of approximately 920 lineal feet of sixteen (16) inch Water Main together with associated valving and fire hydrants.

The City Council has determined that all of the cost of the above described public improvement shall be assessed against the following described property abutting the above described improvement.

22-27-200-006 22-27-200-007
22-27-200-008 22-27-200-009

CITY OF NOVI NOTICE

NOTICE IS HEREBY GIVEN that the City Council has established a Police and Fire Protection Needs Committee to address the needs for Police and Fire Protection. The Committee will be made up of seven (7) residents of the City, one (1) representative of the Commercial Community, one (1) representative of the Industrial Community and one ex-officio staff representative.

Any person interested in serving in this capacity may obtain an application by contacting the City Clerk at 349-4300. Applications should be submitted by May 30th.

Geraldine Stipp, City Clerk
(5-14-86 NR, NN)

TAKE FURTHER NOTICE that the City Council has caused reports concerning said public improvement to be prepared, which reports include necessary plans, profiles, specifications and estimates of cost of such public improvement, a description of the assessment district and other pertinent information, and these reports are on file in the office of the City Clerk and are available for public examination.

TAKE FURTHER NOTICE that the City Council will meet on Monday, June 2, 1986, at 8:00 p.m. EDT or as soon thereafter as the same may be reached, at the Novi Public Library, 45245 W. Ten Mile Road, Novi, Michigan, for the purpose of hearing objections to the making of such public improvement.

THIS NOTICE is given by order of the City Council of the City of Novi, Oakland County, Michigan.

Geraldine Stipp, City Clerk
(5-14-86 NR, NN)

TAKE FURTHER NOTICE that the City Council has caused reports concerning said public improvement to be prepared, which reports include necessary plans, profiles, specifications and estimates of cost of such public improvement, a description of the assessment district and other pertinent information, and these reports are on file in the office of the City Clerk and are available for public examination.

TAKE FURTHER NOTICE that the City Council will meet on Monday, June 2, 1986, at 8:00 p.m. EDT or as soon thereafter as the same may be reached, at the Novi Public Library, 45245 W. Ten Mile Road, Novi, Michigan, for the purpose of hearing objections to the making of such public improvement.

THIS NOTICE is given by order of the City Council of the City of Novi, Oakland County, Michigan.

Geraldine Stipp, City Clerk
(5-14-86 NR, NN)

HIGH BLOOD PRESSURE

Over 60 million people in the United States have hypertension. It is the largest single cause of preventable disability and death. Hypertension is sometimes known as the "Silent Killer" because it often has no symptoms. The cause of hypertension is often unknown, but certain risk factors are well known. With proper evaluation, treatment is usually simple and may help prevent life threatening or disabling conditions such as stroke and heart disease.

For a complete blood pressure evaluation and treatment call Laurel Park Medical Clinic at 464-8222 for an appointment.

37672 Professional Center Drive
Near Six Mile Road and Newburgh
Monday-Saturday with evening hours available

Sweetheart ROSES \$6.99 dozen

Fancy CARNATIONS \$4.99 dozen

Flowering Annuals
Petunias & Marigolds
59¢ Tray \$7.99 Flat of 18

Vegetables
Tomatoes, Peppers, Cauliflower, Cabbage, etc.
49¢ Tray \$7.49 Flat of 18 trays

Tropical Plants
Wide Selection
Large 10" From \$15.99

Hardy Mums
89¢

GERANIUMS 79¢ each
4" Round Plastic Pot Grown from seed

Ground Cover
Pachysandra & Ivy
\$8.99 50 Plants
\$14.99 100 Plants

Peat & Topsoil
40 lb. Bag \$1.49 Reg. \$1.75

Flowers Wired Anywhere • Daily Delivery Metro Area

VILLAGE GREEN 476-4533
Florist & Garden Center
33239 WEST 8 MILE RD., LIVONIA (E. of Farmington Rd.)
Mon.-Sat. 9-8 Sun. 9-4

8 MILE CHARGE BY PHONE WITH YOUR CREDIT CARD

COMPLETE SKIN CARE
MICHAEL J. REDMOND M.D., P.C.
Announces
The Opening of His Office For Treatment of Diseases of the Skin, Hair and Nails
MEDICAL • SURGICAL • COSMETIC

- Acne, Rashes, Skin Irritations
- Warts, Moles, and Skin Growths
- Skin Cancer Detection & Treatment
- Collagen Implant Therapy
- Removal of Spider Leg Veins

FOR APPOINTMENT CALL 464-8400
37672 Professional Center Drive (Located Near 6 Mile & Newburgh) LIVONIA



Novi News/PHILIP JEROME

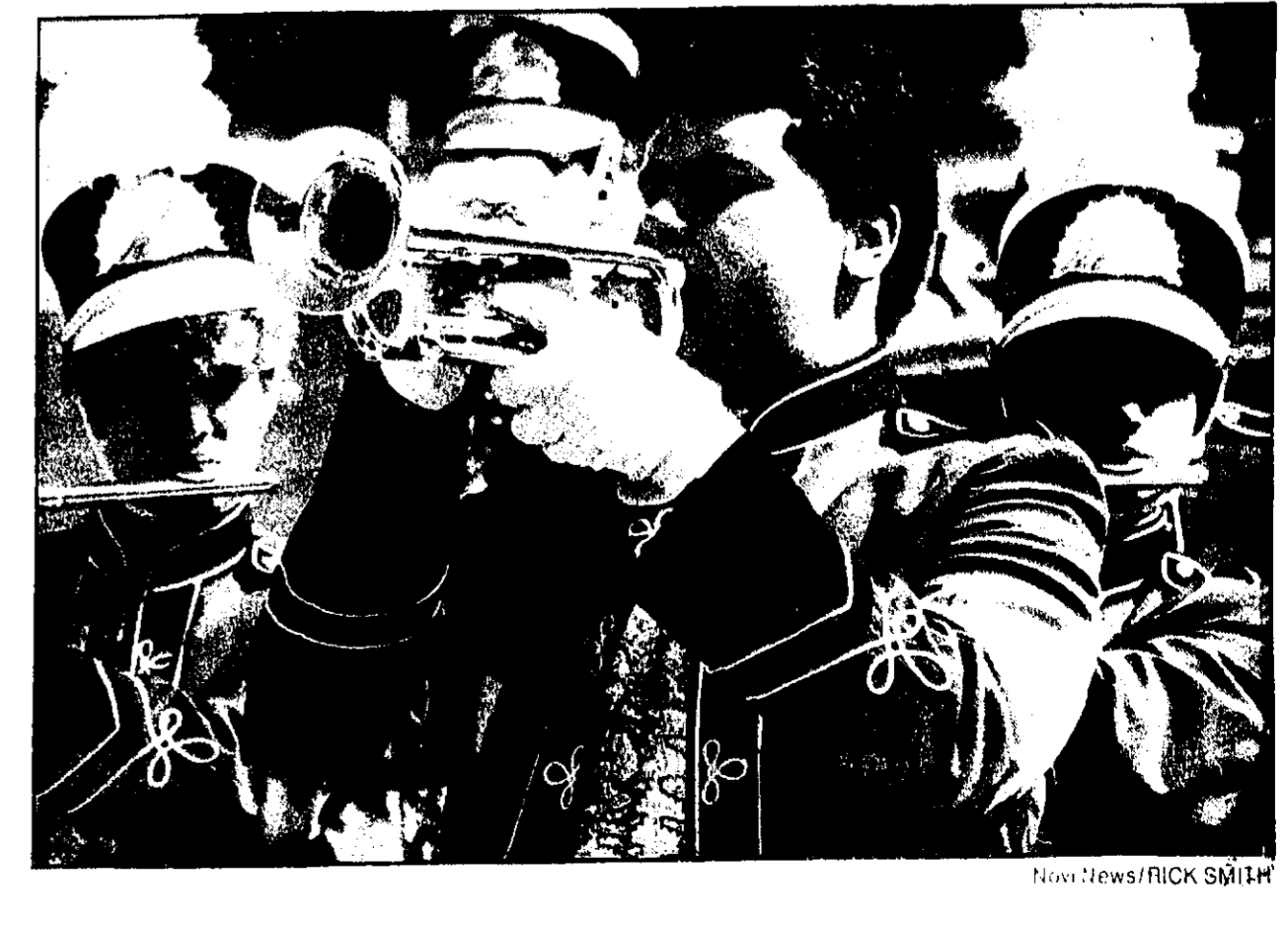

Novi News/RICK SMITH



Novi News/PHILIP JEROME

Truck repair shop gets reluctant OK

Pete Dronchewicz's plans to build a truck and trailer repair facility on the south side of Grand River between Wixom and Beck roads probably beat Novi officials to the punch last Wednesday — much to the chagrin of a neighboring developer.

The location of the proposed facility borders the property that Joseph Gerak and Gloria Geisler have planned as a residential-recreation area. To the north, Gerak intends to build Westbrooke Plaza, an office-hotel-recreation complex. Dronchewicz's site likely was one city planners intended to rezone to align with Master Plan specifications for light industrial zoning — a designation which would not permit outdoor storage of tractors and trailers requiring repair. But since the repair facility site currently is zoned I-2 (general industrial), Dronchewicz is within his rights to build there.

"We've been attempting to get the zoning to agree with the Master Plan," said Commissioner Judy Johnson. "It's difficult to vote for approval when you're establishing a heavy industrial use in an area master planned for light industrial."

Commissioners Joseph Toth and Gary Phillips voted against approval.

Toth said the site plans do not show enough parking area for trucks, trailers or buses which would be stored on the site while awaiting repair.

"They meet the ordinance requirements, but not the requirements of the project they're talking about," said Toth. "I think they've found a loophole in the ordinance."

Toth said he intends to recommend the city revise its zoning ordinance to require more parking for industrial development. "The way I figure it, I-2 districts should provide twice as much parking as they do now, and I-1 districts 1.5 times as much," he added.

Country Epicure plans expansion

Owners of the Country Epicure have obtained approval of plans to build a bake shop and delicatessen on property behind their restaurant at 42050 Grand River.

Plans call for the shops to be added to an existing farmhouse in back of the Country Epicure. In addition, an open-air gazebo and walkway will be built.

Architect Ian Brownley told Novi planning commissioners last Wednesday that owners intend to build a mini-village "appropriate to the scale of the property."

The 2,100 square-foot addition would be the first of three phases part of the shopping area. Phase II calls for another 9,150 square feet of retail space, while Phase III — still in a tentative planning stage — would substantially expand the restaurant, possibly to accommodate banquets. Because of Phase III's sketchy future, commissioners voted to withhold preliminary approval of that part of the site plan.

"The idea is to continue a theme orientation," said Brownley. "Besides the deli and bake shop, maybe it'll be an ice cream parlor, utensils, gourmet items and so forth."

Commissioner Isabel Collins greeted the development enthusiastically. "This could be the most beautiful thing in Novi," she said.

Owners will be required to provide specifics about the usage and capacity of the additional buildings prior to final approval by city planning staff.

High-tech invasion

There was no wiener schnitzel but there was lots of good German beer and apple strudel when groundbreaking ceremonies were held for the Thielenhaus Microfinish Corp. on Nine Mile in Novi last Thursday. Participants in the official ceremonies were (left to right) Mrs. Ernst Thielenhaus; Hans Hermanns, president of the corporation; and Helga Thielenhaus, Mrs. Thielenhaus' daughter. Established in Germany in 1909, the parent company is a pioneer in and one of the world's foremost developers of the microfinish pro-

cess, finishing parts with tolerances to 20-millionths of an inch. Since coming to the United States five years ago, Thielenhaus Microfinish Corp. has grown from a one-man operation to \$15 million in sales in 1986. Thielenhaus has acquired a total of 7.75 acres of land and has the potential of constructing up to 110,000 square feet of office buildings. The first phase of development will contain 27,600 square feet of space and be able to accommodate up to 85 people.

30 years experience

Caswell Modernization

Vinylast

Rigid Vinyl Construction • Siding & Trim
 • Licensed • Free Estimates
 • Insured • We Install

We are the No. 1 Installers in S.E. Michigan

Caswell Modernization Co. Inc.
 "The Replacement Window Specialists"
 Showroom: 9340 Elizabeth Lake Rd.
 Union Lake
698-2081 M-F 8:30-5, Sat 10-4

Medicare Approved

You can be self-reliant again.

EASY-LIFT
 Cushion Lifting Chair

FREE Home Demonstration

If sitting down and standing up by yourself have become difficult or uncomfortable, an EASY-LIFT cushion lifting chair will solve the problem. Just push the control and the unique cushion lifting mechanism provides the gentle lift and support you need. And when it's not lifting or lowering you, the EASY-LIFT is a comfortable chair. And a handsome addition to any room. Choose from several styles, fabrics, and options to make it your EASY-LIFT Cushion Lifting Chair.

Everything Medical Since 1956

FORDSON Health Care Services

Medical Center
 15044 Michigan Ave
 Dearborn, MI 48126
 584-9070

Announcing the Bank-A-Matic/24



Bank with the card that could make you a winner — at Security Bank Oakland County.

Enjoy 24-hour banking and enter to win! Learn just how convenient banking can be — with our new Bank-A-Matic/24 automatic teller service at Security Bank Oakland County.

Your Bank-A-Matic/24 card allows you to make withdrawals, deposits, loan payments, balance inquiries, and to transfer funds from one account to another — with just the touch of a few buttons. It's the easiest way to do most of your banking transactions, 24 hours a day, seven days a week.

And now, to help you discover the convenience of 24-hour banking, Security Bank Oakland County introduces the Bank-A-Matic/24 \$3,000 Giveaway.

A \$500 weekly prize for six weeks. Beginning April 21. Here's how the Giveaway works: Every time you use your Bank-A-Matic/24 card to make a financial transaction, you're automatically entered. The more transactions you make, the more times you're entered. It's that simple!

If you don't have a Bank-A-Matic/24 card yet, come in and get one soon — it's yours when you open a checking or savings account at Security Bank Oakland County. But you should act now. The Bank-A-Matic/24 \$3,000 Giveaway begins April 21 and ends May 30, 1986. Come in today. And bank with the card that could make you a winner.

(Prize not necessarily up to a maximum of \$3,000.00 per week. Balance inquiries do not qualify. Prize is only eligible within 3600 prize drawing promotion. Official game rules are available at any Security Bank Oakland County Branch Office or by writing to Bank-A-Matic/24 \$3,000 Giveaway, P.O. Box 1099, Southfield, Michigan 48035.)

SECURITY BANK
 OAKLAND COUNTY

Novi, Michigan
 A Security Bancorp Bank

Main Office
 41325 Ten Mile Road
 Novi, MI 48050
 (313) 478-4000

Branch Offices
 42393 Nine Mile Road, Novi
 45900 Ten Mile Road, Novi
 30880 Beck Road, Novi
 3111 Baldwin Road, Orion Township
 (Automatic teller service)

You need all the Security you can get.
 Member FDIC

GREEN SHEET

Sliger/Livingston East

Section B
 Wednesday, May 14, 1986

Executive positions opening up in state

Executives at the middle and upper levels could see a growth in job opportunities this year, according to a new survey.

An average of eight positions per company will be filled in 1986. Most of the growth will come in service firms.

Thirteen openings were projected by executives of service firms, while four openings were forecast by manufacturing firms.

There could be a shortage of available talent in Michigan, according to Richard Elwell, president of Elwell & Associates, an executive search firm in Ann Arbor.

"Increased hiring will increase the competition for talent and the organization that succeeds in recruiting the best talent will emerge as the leader in its industry," said Elwell.

The survey was commissioned by Elwell and conducted by Nordaus Research, Inc., of Southfield. Surveyed were presidents, CEOs and other high-level executives of Michigan corporations with sales of \$10 million or more.

"The continuing expansion of existing companies and start-ups of

Nation will celebrate Small Business Week

The nation's 15 million small business owners will be honored during the 22nd annual National Small Business Week (May 18-24).

Under the theme, "Small Business is BIG business in the USA," contributions of small companies will be noted at local and state ceremonies as well as at special activities in Washington, D.C.

Outstanding small business owners from each state, the District of Columbia and Puerto Rico will be singled out for special honors as national examples of success, advocacy and community leadership. The "small business person of the year" will be selected from among the state winners.

Small Business Week, which was proclaimed by President Reagan, is coordinated by the U.S. Small Business Administration.

In addition to the 52 state small business winners, Small Business Advocates of the Year will be honored during the Washington ceremonies. They will include a young entrepreneur, a big business that helped to strengthen small business, a small business exporter and an innovative small business or supporter of small business innovation.

ERA RYMAL SYMES CO.

SALES PERSON OF THE MONTH HELEN SOUTH

YOU OWE IT TO YOUR EQUITY TO CALL US!

478-9130
 41160 W. Ten Mile • NOVI

RYMAL SYMES
 - REALTORS Since 1923 -

FARMINGTON — Distinguished Charm! Super-status brick Condo with swimming pool. One-bedroom with decorator upgrades, gas heat, new carpeting and more for \$34,900.00. Call 478-9130 ERA Rymal Symes

MILFORD — Pure Privacy! Private drive leads to this executive ranch on 10.8 acres with 4 bdr., 2 1/2 baths, formal dining room, study, rec. room, family room with stone fireplace, and doorwall to 16' x 40' indoor pool. If entertaining is part of your lifestyle or job, this is the house for you! \$249,000.00. Call 478-9130 ERA Rymal Symes

FARMINGTON HILLS — Smart brick home featuring country kitchen. Great family area, cheery hearth, decorator upgrades, family room, kitchen appliances included, main-level laundry, woodburning stove, gas heat, fencing, large trees. \$64,900.00. Call 478-9130 ERA Rymal Symes

FARMINGTON — Cute 2 bdr. starter home. Maintenance free, new roof, new furnace & new carpeting in 2 rooms. Nicely decorated, fenced yard and 1 1/2 car garage. Has Buyer Protection Plan. \$35,900.00. Call 478-9130 ERA Rymal Symes

LIVONIA — Lovely Cape Cod decorated in neutral tones. Double-door entry with lg. foyer, bay in formal dining room, family room w/ fireplace, sprinkling system, full basement partially finished and much more! \$130,900.00. Call 478-9130 ERA Rymal Symes

Family Foot Centers
 FREE FOOT CARE

887-5800

Highland Millford Foot Specialists P.C.
 Dr. Lefkowitz, Dr. Steiner, Dr. Richard

Highland
 Across From Slach's
 1183 S. Millford Rd.

FOOT PROBLEMS? Don't Walk in Pain

- Ingrown Toenails
- Diabetic Feet • Heel Pain
- Surgery • Office, Hospital
- Bunions • Hammer Toes
- Corns • Calluses
- Fractures • Sprains
- Asthmatic Feet
- Warts • Hand/Foot
- Child's Feet • Skin Growths
- Sports Medicine • Orthotics

MORN., AFTERNOON, EVE. & SAT. APPOINTMENTS AVAILABLE

MOST INSURANCE ACCEPTED INCLUDING MEDICAID, BLUE CROSS MEDICARE AETNA TRAVELERS, HMO'S, AND AMERICAN OVERSEAS AND ALL OTHER PRIVATE CARRIERS. *EXCLUDES PAY LAB. TREATMENT

WE'VE MOVED! Come See Us At Our New Location!

THIS SUMMER, KELLY WILL HELP 70,000 STUDENTS WORK TOWARD TWO GOALS:

TUITION AND A TAN.

With Kelly Services you can make the most of summer. And still make money for school.

You'll earn tuition while you choose your own assignments: office clerical, marketing or light industrial work. You can take as many assignments as you like, or hold them to a minimum. So you can still spend entire days hunkering in the sun.

Work is almost always available, too. So Kelly is not only ideal for vacations, it's a smart way to spend breaks year round.

And there's an extra benefit. Kelly provides temporary help to 98% of the Fortune 500 firms. So the assignment you take today can help you meet people who could play a big part in your future.

Join the 70,000 other students who work with Kelly Services every year. Just register at one of over 500 Kelly offices nationwide. There's one near your home or school. And it doesn't cost a thing to register. Think ahead. It's a terrific way to earn tuition this summer — and still go back to school with a tan.

KELLY SERVICES

500 W. Main St., Downtown Brighton
 (313) 227-2034

We're Having A SALE!

May 14-May 18 Wed.-Sun.

\$2 OFF

HANGING 16-INCH **MOSS BASKETS**

• VINING GERANIUMS • TUBER BEGONIAS • DOUBLE IMPATIENS

NO LIMIT - WITH THIS COUPON

FOR QUALITY PLANTS...

Brainer's Green House

51701 GRAND RIVER • WIXOM

349-9070

1 1/2 M. West of Wixom Rd.

Business Briefs



FRED SCHULTZ



JERRY HENDERSON

FRED SCHULTZ, a Northville resident and president of National Sales Engineering Corp. in Livonia, was named to a three-year term on the American Machine Tool Distributors' Association (AMTDA) Board of Directors during the association's 81st annual meeting in Scottsdale, Ariz.

Schultz was admitted to the Michigan Bar in 1969. From 1970-73 he served in private practice. In 1973, he became vice president of sales for National Sales Engineering Corporation, until his appointment as president in 1978. He also serves as a director and treasurer of Alliant Machine Tool Corporation, North Kingstown, R.I.

His past involvement with AMTDA includes regional chairman, committee service and a 1985-86 term on the board. He received a BS degree in management from the University of Detroit in 1966 and his J.D. degree in 1969.

He and his wife Sharon have three children: Marlene, 17, Jennifer, 15, and Deborah, 9. Schultz is active in YMCA youth programs and counts golf, skiing, bowling and water sports among his interests. He is a director of Farmington Hills Country Club.

JERRY D. HENDERSON of Northville was named to a newly established sales post by Ford Motor Company's Direct Market Operation, based in Wixom. FDMO coordinates the sales and service programs of Ford dealers in countries where Ford has no operating affiliate.

Henderson, formerly FDMO marketing services manager, has been appointed general sales manager. He joined Ford in 1959 as a Ford Division analyst in the Lansing District Sales Office where he held a series of managerial posts before moving to the division's General Sales Office in 1966 as a market representation coordinator. He was a division general field manager for the Oklahoma City District Sales Office in 1968-70, manager of the Detroit Ford Marketing Institute in 1971, and assistant Detroit District sales manager in 1971-72. He returned to the general sales office in 1972 as sales program manager.

In 1973, he moved to Ford Brazil where he was successively marketing manager and parts and service manager. In 1977 Henderson joined Ford Latin America-Mexico as sales and marketing manager. He was appointed sales and marketing office manager of Ford Venezuela in 1980, and joined FDMO as marketing services manager in 1983.

He holds a bachelor's degree in education from Michigan State University. He was born Oct. 27, 1937, in Kingston, Mich.

THE O'BRIEN CHAPEL of the Ted C. Sullivan Funeral Home is celebrating its 10th anniversary in Novi this month. Sullivan has been a trusted name in funeral service for over 85 years.

Formerly located in Detroit, the chapel opened in Novi on May 2, 1976, with John J. O'Brien as president. The chapel has served many families from Michigan and out-of-state over the past 10 years.

O'Brien is an active member of the National Funeral Directors Association and the Michigan Funeral Directors Association as well as being a consultant to the Michigan Funeral Directors Pre-Need Trust. He also is an active member of the Holy Family Church, Novi Lions Club, Knights of Columbus and the Novi Chamber of Commerce in addition to being a sponsor of Novi Parks and Recreation Department teams and programs.

Newest staff member at the O'Brien Chapel is John P. O'Brien, son of the president. John P. O'Brien holds a BSW degree from Western Michigan University and graduated this spring from Wayne State University's Department of Mortuary Science.

The O'Brien Chapel has become a family affair. John P. O'Brien's three sisters — Bridget, Colleen and Marianne — handle office duties and landscaping responsibilities at the Grand River funeral home, and his brother-in-law, Michael Watt, and mother, Joanne O'Brien, also are on the staff. The only family member not involved is the oldest son, Mark, who will be graduated from the University of Osteopathic Medicine and Health Sciences in Des Moines, Iowa, on May 20.

In addition to celebrating its 10th anniversary in Novi, the O'Brien Chapel was selected by the Novi Chamber of Commerce this year to receive the Landscaping Beautification Award.

DAVID HAWTHORNE of Milford has been named to the AT&T Council of Leaders, an award which recognizes the top three percent of the company's nationwide marketing division for general business.

An account executive for AT&T, Hawthorne is responsible for medium-sized business customers in the Detroit area. He is a graduate of Michigan State University.

JAMES A. MELDRUM of Milford has been appointed branch officer for Comerica Bank's Seven Mile/Telegraph Road office. The announcement was made by Donald R. Mandich, chairman.

Meldrum joined the bank in 1967 as an assistant manager. Since then, he has held positions of increasing responsibilities. Meldrum received his bachelor of business administration in 1967 from Eastern Michigan University. He is currently the third vice president of the Midwest Lions Club.

Comerica Bank is the principal subsidiary of Comerica, Incorporated.



LINDA SUMMERTON of Novi was the first \$500 winner in the \$3,000 Giveaway sponsored by Security Bank Oakland County. Summerton is shown above receiving the check from Security Bank Oakland County's Paul Wilson.

Security Bank Oakland County is giving away \$500 each week during May to a customer utilizing its new Bank-A-Matic/24 automatic teller cards.

The Bank-A-Matic/24 card allows customers to make withdrawals, deposits, loan payments, balance inquiries and to transfer funds from one account to another through the touch of a few buttons. The Bank-A-Matic/24 machines are open 24 hours a day, seven days a week.

Every customer who uses the Bank-A-Matic/24 card to make a financial transaction is automatically entered in the contest. The card is given to anyone who opens a checking or savings account at Security Bank Oakland County.

The Bank-A-Matic/24 \$3,000 Giveaway ends May 30.

N. KELLY SHARKEY has been appointed sales and support manager of The Personnel Department, the new microcomputer personnel software and support services department developed by the Arbor Consulting Group, Inc., of Plymouth, for small and medium-sized businesses, divisions and staffs.

Previously, Sharkey was marketing manager for Total Health Care in Detroit and executive director of the American Dally Association of Michigan. A Northville resident, she is a member of the Adcraft Club, the American Society of Association Executives, the American Society for Training and Development, the Michigan Hospital Public Relations Association and the Professional Women in Sales.

The Arbor Consulting Group, Inc., is a human resources management corporation focusing on career transition, human resources systems and programs for the hourly work force.

GARY UNDERWOOD'S WESTERN SALE

Monday, May 12 thru Saturday, May 17
FREE REFRESHMENTS: PRIZES & FANTASTIC SAVINGS!

<p>1986 ASTRO CONVERSION 7 passenger, overdrive, tilt, cruise, operating package, CL model, 1/2 2118 Was \$16,700 NOW \$15,200</p>	<p>1986 CHEVY SPRINT 2 DOOR Hatchback, auto, rear window defogger, comfort & convenience package, 1/2 372 rust proof package. Was \$6,930 NOW \$6,930</p>	<p>1986 CELEBRITY EUROSPORT 2 DOOR overdrive, V-6, air, loaded, loaded, 1/2 297 Was \$13,764 NOW \$12,577</p>
<p>1986 EXTENDED CAB 4x4 1/2 62152, V-6, overdrive trans., 1000 pound payload, Tahoe Equipment, & much more! Was \$13,108 NOW \$12,287</p>	<p>1986 CHEVY CAVALIER RS 4 door, 5 speed, custom 2 tone rear defogger, alum. wheels, AM/FM Was \$9,312 NOW \$8,707</p>	<p>1986 K-20 PICKUP 4x4 350 V-8, pulse wipers, overdrive, manual locking hubs, extra fuel tank. Was \$14,151 NOW \$12,414</p>
<p>1986 CHEVY NOVA 4 DOOR 1/2 315, 5 speed, 1.6L 2 bbl L4 toyota, P155 blackwalls, cloth buckets. Was \$7,959 NOW \$7,462</p>	<p>1986 CHEVETTE CS 2 DOOR 5 speed, custom CL interior, remote mirror, hatchback. Was \$6,174 NOW \$5,773</p>	<p>1986 CHEVY Z-28 IROC toned port fuel injection, IROC performance package, air, tilt, cruise, power everything. Was \$17,184 NOW \$15,880</p>

We Have All Your Gardening Needs

- Bedding Plants
- Bulk Garden Seeds
- Fertilizer

Large Rhododendron and Azalea Bushes **\$27.95** ea.

Fertilizer 12-12-12 **\$5.75** 50 lb. bag

Wixom Co-operative
49350 Pontiac Trail Wixom 624-2301

PIETILA Bros. Pools Presents
THE CORONADO
THE FINEST POOL MONEY CAN BUY!

This magnificent extruded aluminum deck pool has the massive 12" wide aluminum deck and heavy-duty 2" vertical supports. All of the final extrusion. The Coronado has the finest pool liner available — a 200 lb. vinyl with a smooth, rounded carpeting covers the entire deck, which is also extruded aluminum. The Coronado has two pool ladders for access to the deck and to the pool itself.

Sizes Available —
Full Size Metal On Display In Howell
IN-GROUND POOLS
All Shapes & Sizes Also Available

Open 7 Days A Week
PIETILA POOLS
2075 Grand River 313/476-9678
2075 Grand River 313/476-9678

DECK OUT YOUR PLACE
...with the wood that makes the lasting difference —
OSMOSE **ALL SEASONS WOOD**

New Hudson Lumber
New Hudson 56601 Grand River 437-1423

Flowers For All Occasions

- Weddings
- Funerals
- Showers
- Silk and Fresh

and Much More
Personalized service for all your needs.
Stop by and see us today!

Gift **BON A Shop** **ROSE**

56808 Grand River • New Hudson
One block east of Millford Rd.
437-6465

Big Big Boot and Hat Sale
All Boots 25% Off Our Already Low, Low Price

\$100⁰⁰ Boot Now **\$75⁰⁰**
\$200⁰⁰ Boot Now **\$150⁰⁰**

- Tony Lama Snakes and Lizards
- Texas • Abilene • Acme and • Dan Post Boots

Stetson & Resistol Felts and Straw Hats

\$110⁰⁰ 5x Beaver Now **\$82⁵⁰**
\$55⁰⁰ Felt Now **\$41²⁵**

Sale begins May 16 - May 25

E.R.'s Saddlery Inc.
117 N. Lafayette
South Lyon 437-2821
Hours: M-S 9:30-9; Sun. Noon-5

New John Deere 21-inch deluxe mowers

The top of the line is still inside your budget

The John Deere name has always stood for premium quality. Yet prices are competitive with other deluxe lawn mowers.

And you get a wide choice to suit your exact need: ten 21-in. deluxe models, exclusive to John Deere. Cast aluminum decks; 3 1/2- or 4-hp, 2- or 4-cycle engines. Electric or recoil start. Push-type or self-propelled with variable-speed drive. Automatic blade or engine safety stops. Rear bagger and other attachments available.

Stop in. You don't have to settle for less than a John Deere anymore.

Nothing Runs Like a Deere®

Thesier Equipment Co.
28342 Pontiac Trail South Lyon
One Mile South of I-96 & Kensington Park
Member of the John Deere's "Millionaires Club"

(313) 437-2091
Livingston County Residents (313) 229-6548

We've Corralled A Messa' Trade-Ins For Y'all:

1985 Cadillac Fleetwood	\$21,995	1985 Pontiac T 1000	\$6675
1985 S-10 Blazer	\$10,125	1984 Pontiac Sunbird	\$5925
1984 Chevy Camaro	\$9175	1984 GMC S-Jimmy	\$9325
1983 Olds Ciera	\$6300	1983 AMC Alliance	\$2900
1983 Chevy Van	\$6150	1983 Chevy Hi Cube	\$9200
1982 Ford Escort	\$3050	1981 Plymouth Reliant	\$2750
1981 Chevy Malibu	\$3175	1981 Chevy Citation	\$2975
1981 Chevy Citation	\$2975	1981 Chevy Citation	\$2975
1980 Olds Cutlass	\$2175	1980 Pontiac Phoenix	\$1875
1985 Olds Toronado	SAVE!	1983 Caprice Classic	\$6895

YOU'RE NO. 1 WITH US!

SALES HOURS:
Mon. 8:30 a.m.-9 p.m.
Tue. 8:30 a.m.-9 p.m.
Wed. 8:30 a.m.-9 p.m.
Thur. 8:30 a.m.-9 p.m.
Fri. 8:30 a.m.-6 p.m.
Sat. 9:00 a.m.-3 p.m.

Mr. Goodwrench

MOVING SALE
NOW'S THE TIME TO DEAL!!

Yes, we're moving to our new building and we're selling off present inventory
Yes, Now Is The Time To Deal!!

Nothing Runs Like a Deere®

BAKER'S LAWN & LEISURE
1550 MILFORD RD., HIGHLAND (313)887-2410

GARY UNDERWOOD Chevrolet
603 W. Grand River — Downtown Brighton 229-8800
"Where The People Make The Difference"

GM QUALITY SERVICE PARTS GM
GENERAL MOTORS CORPORATION

DOLL AUCTION
FRIDAY, MAY 16th, 10:00 A.M.
HOWELL RECREATION CENTER
2575 BOND RIVER
HOWELL, MICH.
Dolls including 27 in comp.
Dolls including 27 in comp.

102 Auctions
SALEM HIST. SOC.
PUBLIC AUCTION
SAT JUNE 7th 11 a.m.
Donor's of Consign-Let Us
Sell Your Unneeded Goods...

JERRY DUNCAN'S
AUCTION SERVICE
Farm Estates
Household Antiques
Miscellaneous
437-9175 or 437-9104

EGNAUGH SERVICE
Serving Livingston
County for 17 years.
Estate Antiques and
Furniture.
(517)546-7496

103 Garage &
Rummage Sales
BRIGHTON, May 15, 16
103 Garage &
Rummage Sales
BRIGHTON, May 15, 16

103 Garage &
Rummage Sales
BRIGHTON, May 15, 16
103 Garage &
Rummage Sales
BRIGHTON, May 15, 16

103 Garage &
Rummage Sales
BRIGHTON, May 15, 16
103 Garage &
Rummage Sales
BRIGHTON, May 15, 16

103 Garage &
Rummage Sales
BRIGHTON, May 15, 16
103 Garage &
Rummage Sales
BRIGHTON, May 15, 16

103 Garage &
Rummage Sales
BRIGHTON, May 15, 16
103 Garage &
Rummage Sales
BRIGHTON, May 15, 16

103 Garage &
Rummage Sales
BRIGHTON, May 15, 16
103 Garage &
Rummage Sales
BRIGHTON, May 15, 16

103 Garage &
Rummage Sales
BRIGHTON, May 15, 16
103 Garage &
Rummage Sales
BRIGHTON, May 15, 16

103 Garage &
Rummage Sales
BRIGHTON, May 15, 16
103 Garage &
Rummage Sales
BRIGHTON, May 15, 16

103 Garage &
Rummage Sales
BRIGHTON, May 15, 16
103 Garage &
Rummage Sales
BRIGHTON, May 15, 16

103 Garage &
Rummage Sales
BRIGHTON, May 15, 16
103 Garage &
Rummage Sales
BRIGHTON, May 15, 16

103 Garage &
Rummage Sales
BRIGHTON, May 15, 16
103 Garage &
Rummage Sales
BRIGHTON, May 15, 16

103 Garage &
Rummage Sales
BRIGHTON, May 15, 16
103 Garage &
Rummage Sales
BRIGHTON, May 15, 16

103 Garage &
Rummage Sales
BRIGHTON, May 15, 16
103 Garage &
Rummage Sales
BRIGHTON, May 15, 16

103 Garage &
Rummage Sales
BRIGHTON, May 15, 16
103 Garage &
Rummage Sales
BRIGHTON, May 15, 16

ACCUMULATION
AUCTION
SATURDAY, MAY 17th, 11:00 A.M.
215 MCCARTHY ST.
(Corner of E. Sibby St.)
Victorian chair, French curio cabinet, 5 drawer
chest, 9 pcs. walnut dining set including table, 6
chairs, 2 teacups, china cabinet and buffet, walnut
chest of drawers (pair), 2 chairs, 1 chair, 1
refrigerator, television set, 6 chairs, oak
wardrobe, new electric floor lamp, metal filing
cabinet, sofa, living room chair, end tables,
beds, cabinet stereo receiver w/radio & track
player, Kenmore portable sewing machine, chest
of drawers, girls and boys bikes, table lamps,
misc. chairs, desk, vacuum cleaner, luggage,
beats & h. p. riding mower, quantity of yard tools,
quantity of hand tools, tool boxes, fishing boxes,
poys and pans, software, c.d. glassware, books,
lures and frames, books, oil lamps, lanterns, hand
painted china, fruit jars, and lots more
Not responsible for accidents. Free sale, or free
pickup after deal. Checks accepted with proper
identification.
OWNER: Mr. Midea Hudson
PHONE: (517) 546-7496

SPRING CLEANING AUCTION
SATURDAY, MAY 17, 7 P.M.
WE NEED ROOM! Antiques, Collectibles, Everyday
Household Items, Wall Pump, New Items - Everything
Available For Every Day!
MEL SAUNDERS, 1279 So. Old US-25, Brighton.
We Do Auctions At Our House or Your House!
Call Today - (313) 228-2662 or (313) 224-2707

CHARLES KOEHL, Proprietor
DRAG LINE, P.M. 4.15
Dialysis Center, Home, Hydraulic Control
w/1/2" w/drag scoop & 1/2" drag bucket. Tractor, 3000 lbs.
w/1/2" w/drag scoop & 1/2" drag bucket. Tractor, 3000 lbs.
w/1/2" w/drag scoop & 1/2" drag bucket. Tractor, 3000 lbs.

ANTIQUE AUCTION
MEL SAUNDERS, 1279 So. Old US-25, Brighton.
We Do Auctions At Our House or Your House!
Call Today - (313) 228-2662 or (313) 224-2707

103 Garage &
Rummage Sales
BRIGHTON, May 15, 16
103 Garage &
Rummage Sales
BRIGHTON, May 15, 16

103 Garage &
Rummage Sales
BRIGHTON, May 15, 16
103 Garage &
Rummage Sales
BRIGHTON, May 15, 16

103 Garage &
Rummage Sales
BRIGHTON, May 15, 16
103 Garage &
Rummage Sales
BRIGHTON, May 15, 16

103 Garage &
Rummage Sales
BRIGHTON, May 15, 16
103 Garage &
Rummage Sales
BRIGHTON, May 15, 16

103 Garage &
Rummage Sales
BRIGHTON, May 15, 16
103 Garage &
Rummage Sales
BRIGHTON, May 15, 16

REACH OVER 345,000 POTENTIAL CUSTOMERS EVERY WEDNESDAY AND 136,000 EVERY MONDAY
HOUSEHOLD SERVICE AND BUYERS DIRECTORY
Livingston County Phone 227-4436 or 548-2570 Oakland County 437-4133, 348-3022, 685-8705 or 669-2121 Wayne County 348-3022 Washtenaw County 227-4436

REACH OVER 345,000 POTENTIAL CUSTOMERS EVERY WEDNESDAY AND 136,000 EVERY MONDAY
HOUSEHOLD SERVICE AND BUYERS DIRECTORY
Livingston County Phone 227-4436 or 548-2570 Oakland County 437-4133, 348-3022, 685-8705 or 669-2121 Wayne County 348-3022 Washtenaw County 227-4436

REACH OVER 345,000 POTENTIAL CUSTOMERS EVERY WEDNESDAY AND 136,000 EVERY MONDAY
HOUSEHOLD SERVICE AND BUYERS DIRECTORY
Livingston County Phone 227-4436 or 548-2570 Oakland County 437-4133, 348-3022, 685-8705 or 669-2121 Wayne County 348-3022 Washtenaw County 227-4436

REACH OVER 345,000 POTENTIAL CUSTOMERS EVERY WEDNESDAY AND 136,000 EVERY MONDAY
HOUSEHOLD SERVICE AND BUYERS DIRECTORY
Livingston County Phone 227-4436 or 548-2570 Oakland County 437-4133, 348-3022, 685-8705 or 669-2121 Wayne County 348-3022 Washtenaw County 227-4436

REACH OVER 345,000 POTENTIAL CUSTOMERS EVERY WEDNESDAY AND 136,000 EVERY MONDAY
HOUSEHOLD SERVICE AND BUYERS DIRECTORY
Livingston County Phone 227-4436 or 548-2570 Oakland County 437-4133, 348-3022, 685-8705 or 669-2121 Wayne County 348-3022 Washtenaw County 227-4436

REACH OVER 345,000 POTENTIAL CUSTOMERS EVERY WEDNESDAY AND 136,000 EVERY MONDAY
HOUSEHOLD SERVICE AND BUYERS DIRECTORY
Livingston County Phone 227-4436 or 548-2570 Oakland County 437-4133, 348-3022, 685-8705 or 669-2121 Wayne County 348-3022 Washtenaw County 227-4436

REACH OVER 345,000 POTENTIAL CUSTOMERS EVERY WEDNESDAY AND 136,000 EVERY MONDAY
HOUSEHOLD SERVICE AND BUYERS DIRECTORY
Livingston County Phone 227-4436 or 548-2570 Oakland County 437-4133, 348-3022, 685-8705 or 669-2121 Wayne County 348-3022 Washtenaw County 227-4436

REACH OVER 345,000 POTENTIAL CUSTOMERS EVERY WEDNESDAY AND 136,000 EVERY MONDAY
HOUSEHOLD SERVICE AND BUYERS DIRECTORY
Livingston County Phone 227-4436 or 548-2570 Oakland County 437-4133, 348-3022, 685-8705 or 669-2121 Wayne County 348-3022 Washtenaw County 227-4436

REACH OVER 345,000 POTENTIAL CUSTOMERS EVERY WEDNESDAY AND 136,000 EVERY MONDAY
HOUSEHOLD SERVICE AND BUYERS DIRECTORY
Livingston County Phone 227-4436 or 548-2570 Oakland County 437-4133, 348-3022, 685-8705 or 669-2121 Wayne County 348-3022 Washtenaw County 227-4436

DEADLINE IS FRIDAY
AT 3:30 P.M.

DEADLINE IS FRIDAY
AT 3:30 P.M.

DEADLINE IS FRIDAY
AT 3:30 P.M.

DEADLINE IS FRIDAY
AT 3:30 P.M.

DEADLINE IS FRIDAY
AT 3:30 P.M.

DEADLINE IS FRIDAY
AT 3:30 P.M.

DEADLINE IS FRIDAY
AT 3:30 P.M.

DEADLINE IS FRIDAY
AT 3:30 P.M.

DEADLINE IS FRIDAY
AT 3:30 P.M.

HOUSEHOLD SERVICE AND BUYERS DIRECTORY

Livingston County Phone 227-4436 or 548-2570 Oakland County 437-4133, 348-3022, 685-8705 or 669-2121 Wayne County 348-3022 Washtenaw County 227-4436

Home Maintenance
Handyman
Plumbing
Painting
Roofing
Siding
Flooring
Carpentry
Electric
HVAC
Septic
Well
Pool
Lawn Care
Snow Removal
Garage
Driveway
Fencing
Landscaping
Tree Service
Pest Control
Basement
Attic
Drywall
Scaffolding
Scaffolding
Scaffolding

WINDOW AIR
CONDITIONERS
CLEAN & SERVICE
Lowest Prices Guaranteed
BILL JAMES
PLUMBING & HEATING
NOVI 476-2626

MICHIGAN
ALL PRO
ASPHALT
PAVING
Driveways,
Parking Lots, etc.,
Seal Coating
"All Work Guaranteed"
Free Estimates
(313) 227-7465

BRICK MASON
PATIOS, BRICK, BLOCK
CONSTRUCTION
All types of repair, 18
years experience. Call Craig (313) 437-
1534.

DECKS DECKS
BRICK MASON
PATIOS, BRICK, BLOCK
CONSTRUCTION
All types of repair, 18
years experience. Call Craig (313) 437-
1534.

REPAIRING
REPAIRING
REPAIRING
REPAIRING
REPAIRING
REPAIRING
REPAIRING
REPAIRING

REPAIRING
REPAIRING
REPAIRING
REPAIRING
REPAIRING
REPAIRING
REPAIRING
REPAIRING

REPAIRING
REPAIRING
REPAIRING
REPAIRING
REPAIRING
REPAIRING
REPAIRING
REPAIRING

REPAIRING
REPAIRING
REPAIRING
REPAIRING
REPAIRING
REPAIRING
REPAIRING
REPAIRING

REPAIRING
REPAIRING
REPAIRING
REPAIRING
REPAIRING
REPAIRING
REPAIRING
REPAIRING

ADORA
ASPHALT
SERVICES
PAVING
SEAL COATING
LANDSCAPING
FREE ESTIMATES
JOHN FLEMING
437-5500
JIM TEASDALE
231-3643

C&F CEMENT
ALL TYPES OF
CEMENT WORK
BASEMENTS,
GARAGES,
WALKS,
ETC.
DRIVERS &
COMMERCIAL
30 years experience
(313) 348-2710

ADDITIONS
CARTER
Construction Co.
BRAD, 352-0345 x2

ROOFING
Siding
Waterproofing
Guaranteed
Kitchen & Bath
Remodeling,
Insulated Doors &
Windows and
Much More
(313) 437-4641

SMART SHOPPERS
USE THE
GREEN SHEET
Lee Wholesale Supply
5995 Grand River, New Hudson
437-8844 or 437-5054

GREENVIEW
LAWN
MAINTENANCE
Complete lawn care,
Residential,
Spring Fertilizing,
Mowing, Shrub &
Bed Work, Tree
Trimming,
Complete
Landscaping
(313) 348-0133

GREENVIEW
LAWN
MAINTENANCE
Complete lawn care,
Residential,
Spring Fertilizing,
Mowing, Shrub &
Bed Work, Tree
Trimming,
Complete
Landscaping
(313) 348-0133

GREENVIEW
LAWN
MAINTENANCE
Complete lawn care,
Residential,
Spring Fertilizing,
Mowing, Shrub &
Bed Work, Tree
Trimming,
Complete
Landscaping
(313) 348-0133

GREENVIEW
LAWN
MAINTENANCE
Complete lawn care,
Residential,
Spring Fertilizing,
Mowing, Shrub &
Bed Work, Tree
Trimming,
Complete
Landscaping
(313) 348-0133

MAYHEW'S
SERVICES
RESIDENTIAL
COMMERCIAL
REPAIRS
SEALING
LIME STRIPING
RESURFACING
PAVING
FULLY INSURED
FREE ESTIMATES
(313) 227-0297

MAYHEW'S
SERVICES
RESIDENTIAL
COMMERCIAL
REPAIRS
SEALING
LIME STRIPING
RESURFACING
PAVING
FULLY INSURED
FREE ESTIMATES
(313) 227-0297

MAYHEW'S
SERVICES
RESIDENTIAL
COMMERCIAL
REPAIRS
SEALING
LIME STRIPING
RESURFACING
PAVING
FULLY INSURED
FREE ESTIMATES
(313) 227-0297

MAYHEW'S
SERVICES
RESIDENTIAL
COMMERCIAL
REPAIRS
SEALING
LIME STRIPING
RESURFACING
PAVING
FULLY INSURED
FREE ESTIMATES
(313) 227-0297

MAYHEW'S
SERVICES
RESIDENTIAL
COMMERCIAL
REPAIRS
SEALING
LIME STRIPING
RESURFACING
PAVING
FULLY INSURED
FREE ESTIMATES
(313) 227-0297

MAYHEW'S
SERVICES
RESIDENTIAL
COMMERCIAL
REPAIRS
SEALING
LIME STRIPING
RESURFACING
PAVING
FULLY INSURED
FREE ESTIMATES
(313) 227-0297

MAYHEW'S
SERVICES
RESIDENTIAL
COMMERCIAL
REPAIRS
SEALING
LIME STRIPING
RESURFACING
PAVING
FULLY INSURED
FREE ESTIMATES
(313) 227-0297

MAYHEW'S
SERVICES
RESIDENTIAL
COMMERCIAL
REPAIRS
SEALING
LIME STRIPING
RESURFACING
PAVING
FULLY INSURED
FREE ESTIMATES
(313) 227-0297

MAYHEW'S
SERVICES
RESIDENTIAL
COMMERCIAL
REPAIRS
SEALING
LIME STRIPING
RESURFACING
PAVING
FULLY INSURED
FREE ESTIMATES
(313) 227-0297

MAYHEW'S
SERVICES
RESIDENTIAL
COMMERCIAL
REPAIRS
SEALING
LIME STRIPING
RESURFACING
PAVING
FULLY INSURED
FREE ESTIMATES
(313) 227-0297

MAYHEW'S
SERVICES
RESIDENTIAL
COMMERCIAL
REPAIRS
SEALING
LIME STRIPING
RESURFACING
PAVING
FULLY INSURED
FREE ESTIMATES
(313) 227-0297

MAYHEW'S
SERVICES
RESIDENTIAL
COMMERCIAL
REPAIRS
SEALING
LIME STRIPING
RESURFACING
PAVING
FULLY INSURED
FREE ESTIMATES
(313) 227-0297

MAYHEW'S
SERVICES
RESIDENTIAL
COMMERCIAL
REPAIRS
SEALING
LIME STRIPING
RESURFACING
PAVING
FULLY INSURED
FREE ESTIMATES
(313) 227-0297

MAYHEW'S
SERVICES
RESIDENTIAL
COMMERCIAL
REPAIRS
SEALING
LIME STRIPING
RESURFACING
PAVING
FULLY INSURED
FREE ESTIMATES
(313) 227-0297

MAYHEW'S
SERVICES
RESIDENTIAL
COMMERCIAL
REPAIRS
SEALING
LIME STRIPING
RESURFACING
PAVING
FULLY INSURED
FREE ESTIMATES
(313) 227-0297

MAYHEW'S
SERVICES
RESIDENTIAL
COMMERCIAL
REPAIRS
SEALING
LIME STRIPING
RESURFACING
PAVING
FULLY INSURED
FREE ESTIMATES
(313) 227-0297

MAYHEW'S
SERVICES
RESIDENTIAL
COMMERCIAL
REPAIRS
SEALING
LIME STRIPING
RESURFACING
PAVING
FULLY INSURED
FREE ESTIMATES
(313) 227-0297

MAYHEW'S
SERVICES
RESIDENTIAL
COMMERCIAL
REPAIRS
SEALING
LIME STRIPING
RESURFACING
PAVING
FULLY INSURED
FREE ESTIMATES
(313) 227-0297

165 Help Wanted
CUSTODIAN... Currently accepting applications for full-time custodian...
DENTAL SECRETARY... Our growing General Practice...

165 Help Wanted
EXPERIENCED... PAVE/OPERATOR...
EXPERIENCED... Medical Receptionist...
EXPERIENCED... Lathes hand...

165 Help Wanted
GENERAL shop labor... 12-500 JOBS in all Michigan counties...
NURSE aides needed... Mid State JANITORIAL now accepting applications...

165 Help Wanted
MACHINE JOB SETTER... Good opportunity with well established...
MICHIGAN WORLDWIDE... Looking for young adults to work...

165 Help Wanted
PART-TIME... Will train on the job in the laundry and kitchen...
ORDER PROCESSOR... Applications now being accepted...

165 Help Wanted
LPN OR RN... We are looking for someone with a minimum of 2 years experience...

165 Help Wanted
REGISTERED NURSE... McPherson Community Health Center, a 136-bed acute care general hospital...

165 Help Wanted
FOUR OPENINGS... Sales/field commission...
GYM & SUB BANQUET & LOUNGE... STEEL FABRICATION... THEATRE...

165 Help Wanted
TRANSPORTATION... 201 Motorcycles...
1985 ATC 600. Owner young boy, never raced...

165 Help Wanted
201 Boats & Equipment... 1978 16 ft. aluminum Bass...
1976 16 ft. aluminum Bass... 1977 Yamaha 250 cc. outboard...

165 Help Wanted
COST ACCOUNT CLERK... Person needed in our Howell business office...

165 Help Wanted
EASY ASSEMBLY WORK... \$14.00 per hr. Guaranteed...
GENERAL shop labor... 12-500 JOBS in all Michigan counties...

165 Help Wanted
ORDER PROCESSOR... Applications now being accepted...
LPN OR RN... We are looking for someone with a minimum of 2 years experience...

165 Help Wanted
REGISTERED NURSE... McPherson Community Health Center, a 136-bed acute care general hospital...

165 Help Wanted
FOUR OPENINGS... Sales/field commission...
GYM & SUB BANQUET & LOUNGE... STEEL FABRICATION... THEATRE...

165 Help Wanted
TRANSPORTATION... 201 Motorcycles...
1985 ATC 600. Owner young boy, never raced...

165 Help Wanted
201 Boats & Equipment... 1978 16 ft. aluminum Bass...
1976 16 ft. aluminum Bass... 1977 Yamaha 250 cc. outboard...

165 Help Wanted
215 Campers, Trailers & Equipment... 25' foot Shasta tent bunk house, excellent condition...

165 Help Wanted
215 Campers, Trailers & Equipment... 1978 16 ft. aluminum Bass...
1976 16 ft. aluminum Bass... 1977 Yamaha 250 cc. outboard...

165 Help Wanted
215 Campers, Trailers & Equipment... 25' foot Shasta tent bunk house, excellent condition...

165 Help Wanted
ASSEMBLY LIGHT FACTORY... Our growth has created an opening for an experienced...

165 Help Wanted
OPERATING ROOM HEAD NURSE... McPherson Community Health Center, a 136-bed acute care general hospital...

165 Help Wanted
SECURITY PEOPLE... Full-time, 40 hours per week...
MANAGER needed... Touch of Italy Pizzeria, Full-time...

165 Help Wanted
PART-TIME NURSE... McPherson Community Health Center, a 136-bed acute care general hospital...

165 Help Wanted
ATTENTION! ATTENTION!... Here is your chance to join our largest and most successful...

165 Help Wanted
DURABLE MECHANICAL EQUIPMENT... Durable mechanical equipment for sale...

165 Help Wanted
EARN WHAT YOU ARE WORTH... We are interviewing both licensed and unlicensed individuals...

165 Help Wanted
WONDERLAND MARINE WEST... This Kayak 24' SKIPPER... \$5695

165 Help Wanted
ENCORE... \$14139+... Stock No. 148. Based on 100% Down at 4% Variable for 50 months.

165 Help Wanted
WONDERLAND MARINE WEST... This Kayak 24' SKIPPER... \$5695

165 Help Wanted
WE'VE MOVED... EARN GOOD PAY THE KELLY WAY!

165 Help Wanted
NURSE AIDES... Raised your family? Ready to work outside your home?

165 Help Wanted
NURSE... RN or LPN needed. Patient closed head injury...

165 Help Wanted
MCDONALDS... Experienced cook/service manager or shift leader...

165 Help Wanted
RECEPTIONIST... With over 600 stores nationwide we are progressive...

165 Help Wanted
RECEPTIONIST... With over 600 stores nationwide we are progressive...

165 Help Wanted
RECEPTIONIST... With over 600 stores nationwide we are progressive...

165 Help Wanted
RECEPTIONIST... With over 600 stores nationwide we are progressive...

165 Help Wanted
RECEPTIONIST... With over 600 stores nationwide we are progressive...

165 Help Wanted
RECEPTIONIST... With over 600 stores nationwide we are progressive...

165 Help Wanted
KELLY SERVICES INC... We've Moved... EARN GOOD PAY THE KELLY WAY!

165 Help Wanted
NURSE AIDES... Raised your family? Ready to work outside your home?

165 Help Wanted
NURSE... RN or LPN needed. Patient closed head injury...

165 Help Wanted
MCDONALDS... Experienced cook/service manager or shift leader...

165 Help Wanted
RECEPTIONIST... With over 600 stores nationwide we are progressive...

165 Help Wanted
RECEPTIONIST... With over 600 stores nationwide we are progressive...

165 Help Wanted
RECEPTIONIST... With over 600 stores nationwide we are progressive...

165 Help Wanted
RECEPTIONIST... With over 600 stores nationwide we are progressive...

165 Help Wanted
RECEPTIONIST... With over 600 stores nationwide we are progressive...

165 Help Wanted
RECEPTIONIST... With over 600 stores nationwide we are progressive...

240 Automobiles 240 Automobiles 240 Automobiles 240 Automobiles 240 Automobiles 240 Automobiles 241 Vehicles Under \$1000

1984 CAMARO Rally Sport V-6 auto, loaded, extra... 1978 Corvette White with interior 58,000 miles...

LIVINGSTON COUNTY'S NUMBER ONE USED CAR DEALER. We Buy Clean Cars & Trucks. Call Tom at McDaniel Ford 349-1400.

- 1981 Chevette 2 Dr. ONLY \$1395
1979 Omni 4 dr. auto. ONLY \$1495
1981 Olds Omega 2 Dr. auto. ONLY \$2995
1981 T-Bird Heritage Loaded, leather trim ONLY \$2995
1983 Daton Sentra 2 dr., 4 spd., moonroof. ONLY \$3895
1984 Tempo 2 dr., 4 spd., stereo ONLY \$3995
1984 T-Bird Stereo, auto., p.s., p.b. ONLY \$5895
1982 Mercury Marquis 4 dr., auto, air, stereo ONLY \$5995
1983 Mustang GT T-tops, air, 4 spd., stereo. ONLY \$5995
1983 Buick Park Ave. 4 dr., loaded, stereo, velour. ONLY \$6895
1985 Tempo GL 4 dr., auto, air, cruise, tilt, 15,000 miles, p. locks, stereo cassettes, still under factory warranty. ONLY \$6995
1985 Cougar Full power, stereo, cruise, tilt. ONLY \$9595
1979 Corvette Auto, air, glass tops, leather trim, alum. wheels. ONLY \$9995
1985 Ford Cargo Van 6 cyl., 4 spd., stereo, p.s., p.b. ONLY \$7895
1984 T-Bird V-8, auto, full power, TRX ONLY \$8295
1985 T-Bird V6, auto., air, stereo ONLY \$8995
1984 Merc. Colony Park Sta. Wgn. 10 pass., full power, low miles, stereo, tilt, cruise. ONLY \$8995
1984 Grand Marq. LS 4 dr., every option, low miles. ONLY \$9995
1985 Merc. Colony Park Sta. Wgn. 10 pass., 5,000 miles, still under warranty ONLY \$10,895
1982 Cruise Air 27 Ft. Motor Home Gen., roof, air, awning, 16,000 miles. ONLY \$21,495

HILLTOP FORD MICHIGAN'S LARGEST FORD-LINCOLN MERCURY DEALER. AT THE TOP-OF-THE HILL HOWELL OPEN SATURDAY

1984 Ford Topaz, automatic, air, four cylinder, 29,000 miles... 1985 IROC Camaro Red with T-tops, all options, 8,500 miles...

THE SAVINGS ARE SIMPLY SUPERIOR. CUTLASS CIERA SEDAN. Power locks, tinted windows, body side molding, rear defogger, air, cruise, 2.5 litre, 4 cylinder, no. 428 engine...

5.9% A.P.R. FINANCING AVAILABLE NOW! FREE 300.00 Retail Value DURALINER (Truck Bed Liner) ON ALL 'F' SERIES (EXCEPT FLARESIDE) PICK-UPS SOLD FROM STOCK - ALSO APPLIES TO A, Z & X PLANS

OPEN SATURDAY IN ORDER TO BETTER SERVE OUR CUSTOMERS, SPIKERS SALES DEPT. WILL BE OPEN FROM 10 A.M. UNTIL 4 P.M. BUY or LEASE

OPEN SATURDAY IN ORDER TO BETTER SERVE OUR CUSTOMERS, SPIKERS SALES DEPT. WILL BE OPEN FROM 10 A.M. UNTIL 4 P.M. BUY or LEASE

SPIKER FORD MERCURY. BRING US YOUR BEST DEAL... WE'LL MAKE IT BETTER! 8282 W. Grand River • Brighton 227-1100

1983 Thunderbird Excellent condition. Loaded! Must see! Negotiable. 1975 AMC Gremlin Good condition. Runs great. Am/fm stereo. (517)548-4197.

WE WANT YOUR BUSINESS! Give Us A Try! "The Best Kept Secret in Oakland County for 50 Years" FEIGLEY MOTOR SALES BUICK OLDS

FEIGLEY MOTOR SALES BUICK OLDS. 750 G. M. Rd., Milford. 684-3005

5.9% FIXED RATE ANNUAL PERCENTAGE RATE FINANCING. NOW AVAILABLE ON ALL NEW RANGER PICKUPS! INCLUDING REGULAR CABS, SUPER CABS, 2-WHEEL AND 4-WHEEL DRIVES, AND 'S' MODELS - PRICED FROM \$6195 + TAX. OVER 50 RANGERS NOW IN STOCK!

IT'S AS EASY AS 1-2-3. 1. LOW PRICES 2. GREAT SELECTION 3. LOW FINANCING RATES. We Have It All! 5.9% ON SELECT MODELS. Example: 1986 OLDS CUTLASS CIERA-2 Dr. Was \$12,878.00 Now \$11,488

WE WANT YOUR BUSINESS! Give Us A Try! "The Best Kept Secret in Oakland County for 50 Years" FEIGLEY MOTOR SALES BUICK OLDS

FEIGLEY MOTOR SALES BUICK OLDS. 750 G. M. Rd., Milford. 684-3005

5.9% FIXED RATE ANNUAL PERCENTAGE RATE FINANCING. NOW AVAILABLE ON ALL NEW RANGER PICKUPS! INCLUDING REGULAR CABS, SUPER CABS, 2-WHEEL AND 4-WHEEL DRIVES, AND 'S' MODELS - PRICED FROM \$6195 + TAX. OVER 50 RANGERS NOW IN STOCK!

USED CAR SPECIALS from Mitchell Chevy-Olds. '85 Ciera 4 dr. air, auto., p.s., p.b., cruise 4 door, moonroof. \$8295

- '85 Olds Omega Loaded. \$9495
'84 Chevy S-10 P.s., p.b., radio, 4 door. \$4995
'85 Olds Ciera Loaded, only 12,000 miles. \$9195
'83 Chevy Citation Light blue, 4 door. \$4495
'80 Pontiac Bonneville Loaded, clean, V6. \$3995
'84 Pontiac Sunbird Air, p.s., p.b., auto., stereo. \$5995
'83 Cavalier Station wagon, 4 speed. \$3995
TRANSPORTATION SPECIAL
'77 Monte Carlo 62,000 miles, air, auto. \$1795
'80 Chevy Citation Auto., p.s., p.b., stereo, cruise. \$1995
'76 Chevy Beauville Van \$1995

Mitchell Chevrolet-Olds 307 W. Grand River Farmville 517-223-1129

1979 Ford LTD. 8 passenger wagon, heavy duty suspension. 1975 Ford LTD station wagon. 1975 Olds Omega. 1975 Olds Omega. 1975 Olds Omega.

SUNSHINE USED CARS 453-3600. Financing Available SPECIALS. 1980 AMC Eagle Station Wagon 4x4 \$2888**

CARS • WAGONS • TRUCKS. '82 Corvette T-tops, loaded. YOU MUST SEE THIS ONE! \$10,995

WALDECKER PONTIAC • BUICK. 7885 W. GRAND RIVER • BRIGHTON MI • 227-1761. Over 50 Quality Pre-Owned Cars To Choose From. 6.9% ANNUAL PERCENTAGE RATE AVAILABLE.



Clean out your garage with a garage sale and clean up on savings with the help of a classified ad in the **Monday Green Sheet** and/or the **Wednesday Green Sheet**. Beat the rush and call us before 3:30 p.m. on Friday with your garage sale ad.



Special

When you place your garage sale ad in the **Monday or Wednesday Green Sheets**, you're entitled to a free garage sale kit. Printed in eye-catching green, the kit includes two signs, two directional arrows, a ledger and tips for a successful sale. It's all yours. All you have to do is place your ad and pick it up.

Clean Out (and Up)

You can place your ad in the **Monday Green Sheet**, which is delivered free every Monday to over 49,000 homes in Livingston County, South Lyon and Milford, or you can place your ad in the **Wednesday Green Sheet**, which reaches over 125,000 homes in Livingston County, South Lyon, Milford, Dexter, Northville and Novi.

Or call us before 3:30 p.m. on Friday and you can place your ad in both the **Monday and Wednesday Green Sheets**.

- Brighton (313) 227-4436
- Dexter (313) 426-5032
- Fowlerville (517) 548-2570
- Livingston County (517) 548-2570
- Milford (313) 685-8705
- Northville (313) 348-3022
- Novi (313) 348-3024
- Piackney (313) 227-4437
- South Lyon (313) 437-4133

the NOVI NEWS

ing

MILLIONAIRES:
Athletic Boosters
slate Millionaires Party/2C

NOVI HISTORY:
Staman addresses
Novi Historical Society/3C

1C

TOP SCHOLARS:
Novi Honors Society
inducts 25 new members/3C

SONG CONCERT:
Agape Singers host
concert and magic show/3C

WEDNESDAY
MAY 14
1986

Foiling The Faux-Pas

An easy guide to restaurant *savoir-faire*

By Maureen Naszradi

Proper etiquette for dining out has evolved from stuffy requirements to comfortable practicality. Still, from keeping a reservation to how much to tip to whether to ask for a doggie bag, dining out today with proper etiquette requires a whole set of personal guidelines. No matter which restaurant you decide on, your manners will be noticed by those you dine with and are served by.

Kass Allie, manager and maitre d' of the Crystal Swan restaurant in the Novi Hilton, said manners begin at the door. "My staff takes all the steps necessary to ensure that the customers have everything they need to complement their good manners," he says.

One attempt at proper manners that Allie has noticed often works to the discomfort of a customer. By politely allowing a female dining companion to sit down at a booth first, many men inadvertently force her awkwardly to slide quite a distance before both can be comfortably seated. He says the restaurant staff attempts to divert this process by pulling the tablecloth back or encouraging the male customer to enter on the opposite side of an enjoyable dinner.

Once seated, area restaurateurs agree that most people are ordering for themselves rather than traditionally deferring to men for both orders. Exceptions to this rule might be ordering ahead of time for a large group, deferring to the guest of honor, or letting someone else order for you.

Achille Bianchi, maitre d' at Chez Raphael in Novi, says 15 percent of his customers order dinner without asking for the menu. Because of the restaurant staff's familiarity with the Meadowbrook Country Club members, dining room manager Marcia Weaver says, "We know the member, so we know who the guest is, so we would approach the guest first (when taking orders)."

Ordering from the wife list calls for etiquette for a tradition reserved. The host of the party or the person who orders the wine, if different, can expect to be presented with the bottle, offered an opportunity to sniff the cork, given a taste for approval, and required to give the nod before the other guests are served.

At Chez Raphael, 60 percent of the guests go on Bianchi's suggestion without looking at a wine list. He says diners are familiar with the tasting procedure. "Today, people are very knowledgeable about fine dining and fine wines," he says.

An aspect of etiquette less conspicuous than tasting wine, and therefore often overlooked, is the manner in which diners address the staff. More appropriate than calling "waiter" or "waitress" is to address your server as "sir," "ma'am" or "miss," depending on his or her age. Allie acknowledges, however, that "waiter" is not derogatory because it is a profession.

At Meadowbrook, Weaver says, politeness is never a problem due, again, to the familiarity. Also, she says, "Our waitresses have name tags they are required to wear at all times, so we encourage addressing them by their names."

At Chez Raphael, Bianchi says he hears, "a bit of everything," depending on the relationship established between the server and the customer. Allie says his staff tries to create a certain professional distance while still emphasizing personal attention to detail.

If something goes awry during your evening, not only is it within the confines of proper etiquette to alert immediately your server or the maitre d', but it is encouraged. Whether your complaint is about the meat or the service, Allie says, you are doing no one a favor by not telling the restaurant. Mindful that the maitre d' can not hover over every table and that the servers are human, he says that constructive criticism benefits the restaurant.

Following the meal, the check is presented to the person acting as host. Most restaurants will accommodate requests regarding the presentation of the bill — such as who receives it, whether it will be settled at a later date, or whether it is to be divided among the diners. Area restaurateurs report that separate checks are not frequently requested, but stress the importance of forewarning the server when they are. This practice is discouraged at the Crystal Swan, says Allie, to avoid servers' having to juggle many checks among tables. "They would have to spend too much time with the checks instead of with their customers," he

explains. Proper etiquette calls for a tip to be included on the check. The amount left should reflect the service and the quality of the meal, says Allie. However, if there is a problem, diners should try to determine whether it was the server's fault. If the server had no control, a manager should be contacted and allowed to make amends by removing an item from the check or buying the customer a drink or dessert, says Allie.

At Meadowbrook Country Club, a set percentage of the check total automatically is added as the tip, says Weaver. However, members can add an extra amount if they want. Both Allie and Bianchi report that most customers leave at least 15 percent of the check total as a tip.

When attended by many members of the restaurant's staff, the question of whom to tip arises. At Chez Raphael, the tip on the check is shared by the waiter or waitress, the bartender, the busboy and the wine steward. Tipping the maitre d', which is sometimes done, would require a separate amount.

Chez Raphael maitre d' Bianchi says he is sometimes tipped in appreciation of an enjoyable dinner for which he may have helped select something on the menu or an accompanying wine. Allie at the Crystal Swan said he too is tipped in appreciation through arranging things like a special dessert or flowers.

But, Allie, says, "The days when the maitre d' was tipped before the meal to buy a good table are over." Any tipping is done following the meal today, he says. In addition to tipping, Allie explains he appreciates other methods of expressing satisfaction with the restaurant. "It can be a sincere thank you, a handshake or specific comments about the restaurant," he says.

Bianchi says he has seen an overall improvement in manners in recent years, though specific courtesies, such as standing each time a woman leaves or returns to the table, are seen less often. Allie says he is seeing a trend in etiquette emphasizing comfort rather than stuffiness. Both restaurateurs try to stress comfort while maintaining the ambiance of a class restaurant.

Although most diners are well-mannered, Allie says he still sees some extreme violations of proper etiquette. The no-nos include putting too much food in your mouth at once, talking with your mouth full, talking too loudly, making unsolicited comments to other diners or disturbing neighboring tables in any way.

On occasion, when diners see other customers with whom they are acquainted, there is a proper way to greet them. Approach the table before or between courses so that the meal will not be interrupted. Also, take into consideration the employees navigating among the tables so as not to hinder their work.

Bianchi does not discourage this practice because he feels it is part of the customer's enjoyment of the evening.

The breach of manners that Allie finds most distasteful is some people's smoking habits. Although what individuals do at their own table is their own business, he says as a rule never smoke while there is any food on the table for the consideration of the other diners seated at your table.

"A good restaurant makes it as easy as possible to practice good manners," according to Allie. Related to that policy is the continuing debate over whether it is proper to eat anything with your fingers. Whereas eating a steak that way would be somewhat out of line, Allie says some food, like shrimp cocktail, is designed to be eaten that way, so go ahead.

Related to etiquette, but less debated, is when children should accompany parents to the restaurant. Weaver says Meadowbrook has no problem with children's behavior or manners. However, at the Crystal Swan, precautions are taken.

"Although we don't discourage bringing children, when a reservation is made, we warn that a child has to be well-behaved or we will ask that the child be taken out of the restaurant until the behavior changes so as not to disturb other customers," he points out.

In addition to general manners to be exercised in a restaurant, other codes of etiquette should be followed. Most restaurants have some type of dress code. At Chez Raphael and the Crystal Swan, a jacket is required of men. Meadowbrook requires a coat and tie for evening

dining and has a supply of both to accommodate an unprepared guest. The Crystal Swan also has some extra jackets, but reserves them for more urgent situations only, such as a single member of a group without the appropriate attire. Also related to attire, coat checks are available in most restaurants.

Both men and women, including fur coats, are encouraged to check out if there is a possibility they might be in the way, draped over a chair or otherwise stored at the table. Prior to dining at a restaurant, making reservations is encouraged and sometimes required. How much

in advance depends on the restaurant. At Chez Raphael, reservations for Saturday nights must be made six weeks in advance, though during the week 5-6 hours prior will suffice. Most restaurants have same-day availability. When making a reservation, Allie suggests the customer ask for an availability rather than demanding a specific time, although such requests are usually available. A problem common to all restaurants is reservations made but not kept. Although it does not happen too often at Chez Raphael, Bianchi says there is nothing they can do but absorb the loss when it does. According to Allie, restaurants often overbook reservations in order to prevent the loss resulting from a table left vacant

waiting for guests to show up. "It's very important for people to remember that when they do make a reservation, if something comes up, they should offer the courtesy of a call to cancel that reservation because, in a limited space restaurant, you are holding that space for someone and you could be letting someone use it," said Weaver. Meadowbrook's policy is to hold the table for 45 minutes and call the member while the Crystal Swan affords 15 before designating the table to another customer.

In an attempt to combat the no show problem, Allie said, some restaurants require a credit card number at the time a reservation is made so that in the event the guests fail to appear, a charge is made to their account.



Photo illustration by Jerry Zohnsky

No-Shows

Restaurateurs, customers lose

By JEAN DAY

No shows — those persons who make reservations or appointments, fail to keep them but don't cancel — are becoming increasingly common and costly, especially to small businesses.

The problem of restaurant patrons who fail to honor reservations is not limited to popular restaurants in New York and metropolitan Detroit — it extends to restaurants like Elizabeth's in Northville.

In fact, because the restaurant known for its fine French cuisine is located in a house at 227 Hutton with seating limited to about 60, the situation here is even more acute.

Owners Doug and Elizabeth Campbell note that in serving 60 diners "our profit margin is eight dinners."

"To point out how serious the no-show problem is at Elizabeth's Doug Campbell says that four persons not showing costs the restaurant \$120.

"And you have to think of the waiters and waitresses who lose their tips," he adds. "It's not a small thing," he stresses, noting that no shows cost the restaurant \$3,000 last year.

Campbell admits the situation is worse at Elizabeth's than at restaurants like MacKinnon's at 126 East Main in downtown Northville because there is virtually no walk-in traffic to fill the empty tables.

"Tom MacKinnon admits that 'it's not that much of a problem' at his restaurant because he overbooks reservations by 10 percent. He says, 'It's just part of the business and you're always going to have a table or two of no shows.' MacKinnon says he keeps a list of persons who make reservations and do not show if this has happened two or three times. He anticipates that maybe he will begin to take telephone numbers to confirm reservations on special occasions, such as New Year's Eve. "Ours is a bit unique," Doug and Beth Campbell point out of Elizabeth's policy of

taking telephone numbers with reservations and asking patrons to reconfirm that they are coming.

"It just takes one phone call," Doug says pointing out that he and his wife run the restaurant and are the chefs as well. There is no office staff to take and confirm reservations. On a recent evening, he recalls, he had 60 confirmed reservations — and four did not show even after confirming. He notes also that two patrons who showed up did not stay that evening when they learned they could not bring in their own wine bottle. The restaurant does not have a liquor license but has been attempting to obtain one.

He says that, if a reservation is not confirmed, he tries to do so early the morning of the day for which it has been made. "If we can't reach the person, we have to make the decision on whether to prepare," the Campbells say.

The Campbells have computerized their reservation system by reservation name and telephone number. In so doing, they have been able to keep track of those who made reservations and did not show or call later to explain why.

When a no-show patron calls again to make a reservation, a check later reveals this, Campbell says, explaining that he then does not accept the confirmation. It is this policy that has caused the Campbells public relations problems as turn-away customers have been irritated.

But Campbell says, "we're not here to create enemies." He emphasizes that the policies have been instituted to help the restaurant stay in business. Genitt's Hole in the Wall Italian restaurant at 100 East Main caters to groups with its popular Italian dinners and has very few no shows, less than five percent. Kathy McLeod who handles reservations reports. She attributes this to the fact that the restaurant requires a substantial deposit for any group larger than eight. Usually the cancellation or no show is because of illness.

she says, with only the ill member of the party not coming.

Novi Hilton manager Gary Selbert says no shows are "not really" a problem in the hotel's Crystal Swan restaurant because telephone numbers and names are taken with reservations. "Whenever we can, we call back and confirm," he explains, adding that the policy "gives us the opportunity to resell space." This is especially important for buffets for such special occasions as Easter and Mother's Day.

"Oh, sure, we have no shows," says Keith Famie, chef of Chez Raphael at the Sheraton Oaks, "but that is expected — we always overbook. He adds that "the problem is not as great (at Chez Raphael) as at some restaurants because, when our customers cancel, they usually call."

Several stylish New York restaurants surveyed in a New York Times article earlier this year said their experiences with no shows reflected an industry-wide problem that affects restaurants of all types and sizes.

Giuseppe Bruno, a co-owner of Sestina, said the average Saturday night no show rate is 20 percent, and slightly less on other days.

He reported that the restaurant would be closed on New Year's Eve this year after several parties failed to arrive, including one table for eight that had been confirmed and reconfirmed and which resulted in a loss of \$700 to \$800 last New Year's Eve.

A big restaurant can make up for no shows by overbooking a little and making other adjustments, Joseph Reyers, the maitre d'hotel at La Cote Basque in New York, was quoted as observing. The small restaurant, he said, gets burned most severely. The no-show problem facing restaurants is similar to that facing airlines that in charter situations also have found that requiring deposits or prepayments is the safest way to operate.

Walled Lake hosts blood drive

The Walled Lake Community Education Department will hold a blood drive at Walled Lake Central High School on Thursday, May 15, from 2:30 to 8 p.m.

Community Notes

TRAFFIC PATROLS: The Novi Police Department is sponsoring a spring theater event called "Portraits of Women," a collection of readings taken from plays, short stories and news written for, and about women.

PORTRAITS OF WOMEN: The Womencenter of Oakland Community College (OCC) is sponsoring a spring theater event called "Portraits of Women," a collection of readings taken from plays, short stories and news written for, and about women.

VOLUNTEERS: The American Cancer Society of Oakland County needs volunteer drivers willing to transport patients to area hospitals between the hours of 8 a.m. and 5 p.m.

CANCER SUPPORT: Henry Ford Hospital's West Bloomfield Center will hold a free "Focus on Living" group at 7:30 p.m. the second Tuesday of each month.

EMBROIDERERS GUILD: The Farmington Hills chapter of the Embroiders Guild of America meets the first Wednesday of each month at 10 a.m. in the Faith Covenant Church at the corner of Fourteen Mile and Drake Road in Farmington Hills.

WESTACRES LIBRARY: A program entitled "On an Even Keel: Boating Safety for All Hands" will be presented at the Westacres branch of the West Bloomfield Township Library on Tuesday, June 3, at 7:30 p.m.

People

Two Novi residents — J. MICHAEL WINNER and SANDRA SANGOT — have been inducted into the Schoolcraft College chapter of the national honor fraternity, Phi Theta Kappa.

JIM YOUNG of Novi has been elected for membership into Tau Beta Pi, the national engineering honor society. A 1983 graduate of Novi High School, he is the son of Mr. and Mrs. Norman Young of Balcombe in Novi.

DANIEL BRINKER of Novi is participating in Kalamazoo College's career development internship program. A Novi High School graduate, he is the son of Mr. and Mrs. William D. Brinker of Mill Stream Lane.

the NOVI NEWS Sports

Novi netters stunned by tough KVC squads

The season is growing longer and the wins harder to come by for the Novi tennis squad.

Three straight losses last week dropped the Wildcats' record to 4-9 overall and 2-9 in the KVC. On May 6, Howell had little trouble in a 5-2 win over Novi and then two more defeats to Lakeland (4-3) and Milford (7-0) wrapped up a week that Coach Jim Newbold would very much like to forget.

After winning at a 500 clip for the first half of the season, the Wildcats are now way below that and have now dropped five of the last six. "I'm just hoping the kids can get it together for the regionals and maybe a few of them can get into the second or third rounds," Newbold said. "The main thing is that the underclassmen get exposure to this type of competition so they will be better prepared next year."

Newbold: 'Some of our scorers look bad, but if you examine it closely, we are winning our share of points but losing the real important points. It seems like every time it gets to deuce, we end up on the short end of it.'

The season is growing longer and the wins harder to come by for the Novi tennis squad. Three straight losses last week dropped the Wildcats' record to 4-9 overall and 2-9 in the KVC. On May 6, Howell had little trouble in a 5-2 win over Novi and then two more defeats to Lakeland (4-3) and Milford (7-0) wrapped up a week that Coach Jim Newbold would very much like to forget.

"I thought we would do a lot better in this one," Newbold said. "Again, in the tight points we seemed to blow it. If you look at the scores, there are a lot of 6-4 sets. In a lot of those, it was tied 4-4 and then we just let it slip away." Boksha looked sharp in a routine 6-4, 6-2 win at first singles against Howell's Bob Hyson 6-3, 6-3. The other win came from the doubling team of Darrin Beyea and Eric Cupp who slipped by Jerry Schultz and Mark Bolten 6-4, 7-6.

HOPES FADING: Novi thinclads lose chances for KVC victory/6C	SHOCKER: Lowly Hartland nine takes two from Wildcats/8C
TAMMY SHINES: Onfrey sparkles as Ladycats show strength/7C	ULTRA-MARATHON: City officials plan in 24-hour running event/8C

5C
WEDNESDAY MAY 14 1986



Novi's Tom Wigley goes high to return a shot.

Schram sparkles for Novi thinclads

If it weren't for Dave Pletcher at Milford High School, Novi's Brian Schram would be the KVC's top high jumper.

All it really means is that Schram will have to wait until next season before he is able to claim high jumping honors. Currently, Pletcher has topped the 6'7" mark, while Schram's top jump is 6'2". The difference is that Pletcher is a senior and will be long gone next year. Schram, on the other hand, is just a sophomore and is guaranteed to improve with each successive season.

As a team, the Wildcats placed fourth out of nine teams, but more importantly, topped all but one KVC team in the process. "We beat Howell, Lakeland, South Lyon and Milford," Novi Coach Bob Smith said. "It was a very productive meet and it gives us hope for the future."

Western inducts 54 honor students

WALLED LAKE — Fifty-four seniors and juniors have been inducted into the Walled Lake Western High School chapter of the National Honor Society.

Joseph Decker, Renee Ebert, Cathy Erdody, Laurie Floto, John Gilbert, Renee Hainer, Eric Hamilton, Duane Harvey and Jodi Hoepke. Other juniors inducted into the society were Shari Hunter, Colleen Jacobsen, Jill Junnola, Jeff Kingston, Michael Kodj, David Mensch, Jody Neumann, Sue Pasquantonio, Lorri Perry, Wendy Reimer, Sam Rowen Jr., Jim Schneider, Bernice Seikalar, David Singh, Garth Skovgaard, John Caldwell, Dawn Campion, Lorrie Capecchia, Meissa Champion, Malinda Cole, Erin Cooper, Shawn Cottrell, Scott Coulter, Wendy Cross,

Novi slates kindergarten round-ups

Novi Community Schools has announced the tentative schedules of this year's "Kindergarten Round-Up" for children who will be heading to the public school classroom for the first time next fall.

The engagement of Paula Jeanne Ginn of Novi to Gregory Neal Mason of Swartz Creek is announced by her parents, Mr. and Mrs. William L. Ginn Sr. of Ridge Road East in Novi.

Engagement

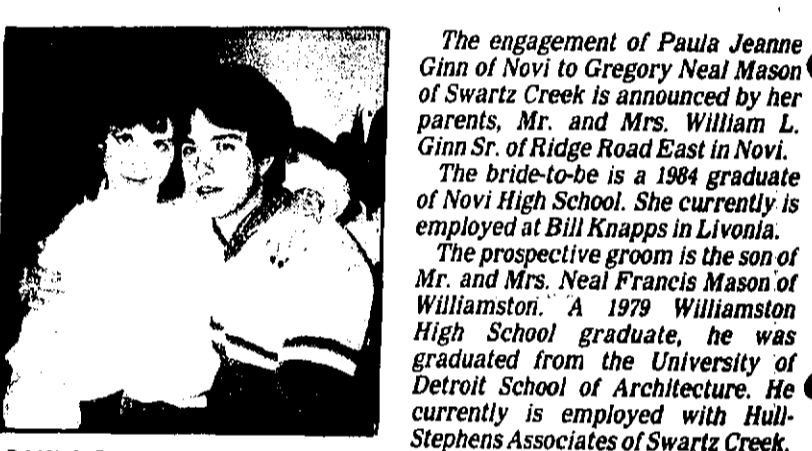

PAULA GINN and GREGORY MASON

Age 30 to 60?
You may save big money on your auto insurance.

Married or single, qualified men and women may save plenty on car insurance with Farmers exclusive 30/50 Auto Package.

Jim Storm
43320 W. 7 Mile
(across from Little Caesar's)
Northville
349-6810

The Sign Of A Quality Home.
"SOLD!"

If you have a higher priced home, one whose quality and specialness you wouldn't trust to just any real estate firm, consider the advantages of marketing it with my CENTURY 21 office.

Jim Storm
43320 W. 7 Mile
(across from Little Caesar's)
Northville
349-6810

BROAD WERNER
Marketing Consultant
Associate Broker
Business 313/452-9605

AH-H-H, SPRING!

IT'S SPRING — AND THE HOT DAYS OF SUMMER WILL SOON BE HERE. BUT NEVER FEAR! CASABLANCA FANS — THE SUPER FANS THAT HELP YOU "KEEP YOUR COOL" — ARE HERE RIGHT NOW.

CASABLANCA FAN COMPANY

10 DAY SALE
SALE ENDS MAY 24

OUR FULL RANGE OF EASY-TO-INSTALL, SLUMBER-QUIET® FANS — FROM OUR STANDARD 3-SPEED TO THE INCREDIBLE, PROGRAMMABLE INTEL-TOUCH® — ARE ALL AFFORDABLE DURING THIS MIGHTY 10-DAY SALE.

CASABLANCA FANS CARRY A 10-YEAR WARRANTY.

STARTING AS LOW AS \$175.00

BROSE ELECTRICAL CONSTRUCTION, INC.
37400 W. 7 MILE ROAD, LIVONIA, MI 48152 • (313) 464-2211

TWELVE OAKS TIRE CO.
22900 Grand River
Novi
348-9900

Michelin • Goodyear • Kelly Springfield

USED TIRES
Truck Tire Road Service

Laurel FURNITURE

OAK DINING SET \$599.98
Reg. \$999.98

Includes 42" Round Table, 1-1/2" Apron Leaf, 4 Bow-back Oak Chairs. Light or Dark Finish.

584 W. ANN ARBOR TRAIL, PLYMOUTH 483-4700

POOL SERVICE

FREE ESTIMATES AND QUOTES

SHOPE AND COMPARE SIZE AND STYLE FOR EVERY BUDGET

FREE IN-GROUND SURVIV

DEEP END AVAILABLE

DISTRIBUTION OF winter pools

MAINTENANCE AVAILABLE

CARE-FREE ALUMINUM POOL WITH DECKS

FULL SIZE INDOOR DISPLAY

SERVICE SPECIALISTS
ALL ABOVE GROUND RECTANGULAR IN-GROUND WINTER POOLS

FREE HOME INSPECTIONS
WE SERVICE ALL AREAS

CHEMICALS • SUPPLIES • ACCESSORIES

528-3620

1974 E. WATLES RD. (17 MILE) WEST OF JOHN R. - TROY

Casterline Funeral Home, Inc.

SERVING YOU FOR 3 GENERATIONS

Funeral planning on pre-need, cremation services available, assisting families with benefits, domestic & foreign shipping & receiving.

122 West Dunlap Street, Northville, MI 48167
(313) 349-0611

RAY J. CASTERLINE 1893-1952
FREDA A. CASTERLINE - RAY J. CASTERLINE II

The Funeral Service:
an effective way to meet genuine needs

19091 NORTHVILLE ROAD
NORTHVILLE 48167

ROSS B. NORTHROP & SON
FUNERAL DIRECTORS

22401 GRAND RIVER
OLD REDFORD 531-0537

The death of a loved one is an extremely difficult time. Our professional staff offers assistance and support to ease the anxiety of grief. Your needs are of primary importance when making funeral arrangements.

Our trademark for 76 years has been caring, quality service. We continue in that tradition.

Wolmanized

Pressure-Treated Lumber
We have treated lumber for all your outdoor projects! All our top quality material is guaranteed for life against rot & decay.

Ponderosa Pine is the best material for your projects. It is treated to a .40 retention & has many advantages over Yellow Pine.

- Better Appearance
- Easier to Cut
- Less likely to split or warp

WE STOCK 2" Dimension Lumber Landscape Timbers Peeler Cores Fence Boards

Delivery Available • **Package Pricing**

NORTHVILLE LUMBER CO.
313-349-0220

OPEN 7 DAYS
Mon-Fri 9-5
Saturday 8-5
Sunday 10-7

Curtis Mathes FOUR YEAR WARRANTY

\$10,000 Search!

For the oldest working Curtis Mathes TV. And any old TV is worth up to \$300 with the purchase of a new Curtis Mathes. Offer ends May 31st.

20" TV MONITOR \$38 per month

Stereo TV \$42 per month

24 MO. REVOLVING CHARGE

Stereo \$26 per month

VCR \$499

Easy Monthly Financing Available

Curtis Mathes HOME ENTERTAINMENT CENTER
A little more expensive...but worth it!

WESTLAND 34794 WARREN ROAD (313) 525-5110

ANN ARBOR KROGER-PERRY CENTER 4703 WASHTEWAN AVE (313) 434-1333

HOURS MON-FRI 10-9, SAT 10-8, SUN 12-5

Wildcats of the Week



KELLI O'NEILL

Kelli O'Neill has been a dream come true for Chris Ceresa, coach of the Novi girls' track team.

Against Hartland in a dual meet last week, O'Neill broke her own school record in the shot put (33'6") and topped this season's best effort in the discus (91'3") as well. The two efforts were only good for second place finishes, but that hardly lessens the accomplishment.

Against Howell two days later, O'Neill placed first in the same two events despite having to battle a brisk head wind.

For her outstanding work last week and throughout the season, O'Neill has been selected as a "Wildcat of the Week."



FRANZ SAMSON

Franz Samson has a tendency to peak at the end of the season. After a slow start, Samson is beginning to flex his muscles in both the shot put and discus — just in time for the league and state meets.

For the first time this season, Samson won both events against Hartland on May 6. His throw of 41'11" in the shot put was his best of the season as was his effort in the discus. Samson topped his previous season best mark by a whopping 20 feet to win the event with an effort of 129'2".

He followed it up with a pair of seconds against Howell — a 41'1" in the shot and a 114'4" in the discus.

For his efforts, Samson has been selected as a "Wildcat of the Week."

Sport Lines

SUZANNE BECKMAN is a member of the varsity softball team at Northwood Institute. A 1983 Novi High School graduate, she is the daughter of Robert and Mary Beckman of Stonehenge in Novi.

Beckman, who plays second and third base, lettered as a freshman and has been a starter in both her sophomore and junior seasons.

She was a standout softball player during her prep career at Novi, winning All-Area honors during her senior year. Beckman is a junior at Northwood.

Sport Lines is designed to carry news about individual accomplishments in sports and recreational activities. Anyone wishing to report news about golf, fishing, hunting, bowling or other recreational or athletic pursuits may call Phil Jerome at 349-1700.

Title hopes fade for Novi nine

By NEIL GEOGHEGAN
staff writer

What began as a very promising week, ended in disaster for the Novi baseball squad.

Heading into the big May 5 doubleheader with Lakeland, the Wildcats were just one-half game out of first place in the KVC race. The way Novi Coach Gar Frantz had it figured, if the team could somehow win the opener, they should have no trouble pulling out the second one — not with pitching ace Jeff Tanderys on the mound.

The Wildcats did win the first game, an 11-10 slugfest and everything looked peachy. But the unlikely happened in the nightcap as the Eagles tagged Tanderys with his first loss of the campaign, a 4-0 shutout.

"I guess nothing is for sure," Frantz said. "I guess we let up a bit with Jeff pitching and it cost us."

Then came a twinbill with cellar-dwelling Hartland — a team that had yet to win a KVC game. With a 4-2 record heading in and destiny in its own hands, Novi dropped both ends of the doubleheader, 11-5 and 7-3, thus ruining any real chances of a shot at the KVC title.

"If we would have swept Hartland, we'd probably be in the driver's seat," Frantz said. "Now, we have to win all the rest of our games and hope for a tie."

The first game with Lakeland was

a high-scoring affair with Novi (9-8 overall, 4-4 in KVC) fighting from behind most of the way. Wildcat starter Brent Daniels was roughed up for five runs in the first, the big blow a two-run homer by the KVC home run leader Darryl Noren.

But Novi put on an offensive show of its own in bottom of the first to tie it up. Paul Spranitis lead off with a double and scored on a single by Greg Giorgio. Steve Shankel then singled and two more runs scored following a hit-batter and a sacrifice by Mike Bobbish. The fourth and fifth runs scored as Tanderys emptied the bases with a double to tie it up.

Lakeland took the lead again with a run in the second, but the Wildcats came back to tie it with another leadoff double by Spranitis and another RBI hit by Giorgio.

Novi finally grabbed the lead with two runs in the third, including a solo homer by Tanderys, and added another in the fourth to go up 9-6.

But the Lakeland assault wasn't over yet as they added two in the fifth on three hits to make it 9-8. Three consecutive hits by Novi's Dave Skown, Giorgio and Shankel upped the margin to 11-8 and the Eagles' two runs in the sixth just weren't enough. Samolin came on in short relief and put Lakeland down 1-2-3 in the seventh for the win.

Coming off a 13-hit game in the opener, the Wildcats could buy a hit off Eagle pitcher Fred Charles in the

nightcap. The only blemish on Charles' pitching line was a fourth-inning bunt single by Spranitis.

"It wasn't like (Charles) was overpowering us," Frantz said. "He only had four strike outs, but seemed to get the outs when he needed them."

Meanwhile, Tanderys was having control problems. In the second inning, three walks and a throwing error (by Tanderys) helped Lakeland score the game's first run without a hit. Later in the fifth, a questionable call at home plate and a triple by Noren pushed the lead to 4-0.

Despite only giving up three hits, Tanderys was saddled with the loss as Novi went down in order the final two innings.

"Lakeland is the best hitting team in the league — no doubt about it," Frantz asserted. "We knew they would be tough, but it wasn't until the sweep at Hartland that we were really in trouble."

Daniels only lasted 1½ innings in the opener as Hartland exploded for six runs in the second inning, wiping out a 2-0 Novi lead. Frantz brought Samolin in to get the final two outs of the inning but then went to Giorgio because Samolin was scheduled to start the second game.

"Brent didn't pitch all that bad," Frantz said. "We had a lot of errors. I just don't think we were mentally ready to play that day."

In the third, Giorgio and Shankel had back-to-back singles and

Tanderys drove them both in with a double to cut it to 7-4, but Hartland scored four more off Giorgio later in the inning to put it out of reach.

"It's hard to put your finger on, but basically we just didn't play well," Frantz explained.

In the nightcap, Samolin was shaky in three innings of work, giving up seven runs and eight hits before Keith Motyka came in to put out the fire. In the final three innings, Motyka surrendered just one hit and no runs, but Novi didn't really put any offense together until the last inning when they trailed 7-1. Andy Trombly singled and scored on a hit by Spranitis who later scored on a hit by Giorgio — the two runs changed the score but not the outcome.

"It seems like we never generate any offense when the pressure isn't on," Frantz complained. "We never get rallies going with two outs and nobody on."

Now, with a pair of doubleheaders against tough Howell and South Lyon remaining on the schedule, all Novi can hope for is a sweep in the four and some help along the way.

"The league is so even," Frantz said. "If we win the rest, there will probably be a big jam at the top of the standings, but you never know."

"We're not in a good position now because we can't win it all by ourselves. We need help from other teams and you sure can't count on that."

City official races in 'ultra-marathon'

By NEIL GEOGHEGAN
staff writer

Jim Wahl uses outlines, designs, arrangements, concepts and strategies everyday in his job as planning director for the City of Novi, but few realize his favorite hobby also requires a great deal of planning.

Wahl is a runner. Not short runs or sprints, either. He loves the long runs. The longer the better.

For the fourth straight year, Wahl has participated in what is probably the most enduring competitive run available — the 24-hour marathon. On May 4, Wahl travelled to Rochester, N.Y. for the Strong Children's Fund Ultra-Marathon and ran for a whole day along with 12 other individuals.

"There were quite a few relay teams, but only 12 of us ran it as individuals — we didn't have any help," Wahl reported.

With experience and some solid

pre-race planning, Wahl overtook a majority of the runners in the last 12 hours of the event and placed third overall.

"In this kind of event, everybody has his own system," he said. "From experience you find out what works for you. I was trying to run 48 or 50 minutes an hour and then take a break."

"That was getting me just over four miles an hour and I stayed consistent with that almost the whole race. It worked pretty well."

Wahl's relatively conservative system put him in an early hole after 12 hours as he found himself running next to last. As the other runners started to fade because they had pushed too hard in the early going, Wahl started to move up and eventually passed seven of them.

"There were guys who were 20 or 30 miles ahead of me at the halfway point, but if your body ties up you're finished real fast," he said. Some of the other guys pushed too hard and

attrition took over.

"It's not as grueling as you think — if you have a system and it works right. Regular marathons are usually more draining because you are running harder."

Wahl should know about marathons — he is one of the busiest marathon runners in Oakland County. In just four years, he's completed in 42 marathons.

"I'd say Doug Curtis is probably the only marathoner who runs more than I do in the county," Wahl estimated.

As the end of the 24 hours drew close, Wahl felt he had saved enough energy to run the final six or eight miles without stopping. But with one mile left, his energy was gone and he was forced to walk most of the way.

"At the end, I was totally exhausted and they had to carry me in to the locker room on a stretcher," he reported. "I was running pretty conservatively, but you have to watch your energy levels very closely."

In the 24-hour span, Wahl had covered 101 miles, topping his previous best mark of 85.

"The 100 miles is kind of like a benchmark," he said. "It's like hitting 300 in baseball — it's something that everybody in this type of running is trying for."

Wahl began running seven years ago to keep fit. Now it has developed into a much more time-consuming hobby that requires a lot of dedication. The reason he became involved in the 24-hour ultra-marathon is because it's always been a fascination.

"Very long runs that sometimes lasted several days used to be a big event in the 1800s," Wahl pointed out. "And now, it's coming back."

For the first time, Wahl plans to run two 24-hour events in the same year. His next ultra-marathon will be in Monroe, Mich., in August.

You can be sure Wahl's planning his strategy right now.

GARDEN PLANTS

100% MONEY-BACK GUARANTEE

Super Jumbo Geraniums

\$2.25
4 1/2" pot

10" Hanging Baskets

(All Colors)

- Non-Stop Begonias
- Hybrid Impatiens
- Fuchsias
- Ivy Geraniums

\$12.95

Impatiens and Begonias

(All Colors)

Pack of 4 \$1.00
Flat of 48 \$10.00

All Kinds of Vegetable Plants

Pack of 4 75¢
Flat \$7.00

Largest Selection in the area

Annuals
From Alyssum to Zinnias
Pack of 4 **85¢**
Flat of 48 **\$8.00**

Dinser's Greenhouse
—Novi
"Quality Growers for 75 years"
Wixom Road at 10 Mile
Novi
349-1320

RAINY-DAY SPECIALS
Rainy Days are Bargain Days!
Stop in on any rainy day and receive a variety of random selection specials!

Open 7 DAYS

Avis SuperValue weeks will make your day.

SuperValue Weekly Rates

\$95 \$115 \$135

- | | | |
|---------|------------------------|----------------------|
| Arizona | California | Connecticut |
| Florida | Colorado | Delaware |
| Hawaii | Georgia | District of Columbia |
| Houston | Illinois | Idaho |
| | Indiana | Kansas |
| | Iowa | Maine |
| | Kentucky | Maryland |
| | Louisiana | Massachusetts |
| | Michigan | Missouri |
| | Minnesota | Nebraska |
| | Mississippi | New Hampshire |
| | Nevada | Pennsylvania |
| | New Mexico | Rhode Island |
| | North Carolina | Upstate New York |
| | Ohio | Utah |
| | Oklahoma | Vermont |
| | Oregon | Virginia |
| | South Carolina | West Virginia |
| | Tennessee | |
| | Texas (except Houston) | |
| | Washington | |
| | Wisconsin | |

Rates apply to the rental of a Chevrolet Chevette or a similar subcompact group car.

Avis SuperValue Rates are available across America. And they're backed by our famous "We try harder" spirit! For details, see your travel consultant or call us at 1-800-331-1212.



So easy.™

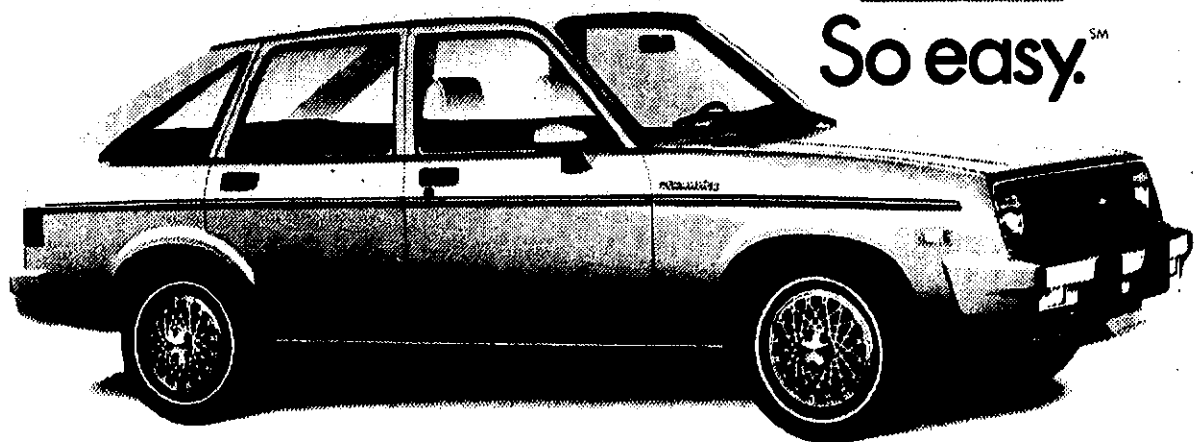

Avis features GM cars. Chevrolet Chevette

7 day advance reservation required. Cars subject to availability. These nondiscriminatory rates are available at participating U.S. locations and subject to change without notice. Surcharge/blackout periods may apply. Cars must be rented for a minimum of 5 consecutive days at a higher rate will apply. Saturday night/sunday return in Florida. Same city return, same state return in Florida. There is an additional per mile charge in excess of the free mileage allowance. Refueling service charges, taxes, optional coverages not included. © 1986 Avis Rent A Car System, Inc. - Avis

ADVERTISING SUPPLEMENT TO: Macomb Daily, Observer & Eccentric, Mellus Newspapers, News Herald, Community News, Sliger Newspapers, Royal Oak Tribune, Dearborn Press & Club, Advisor and Oakland Press.



**HURRY!
SALE ENDS
JUNE 1ST!**



MASTER CARD &
VISA WELCOME

*Start your summer
at Pine's
On!*

Save \$500

Rustique semi-transparent wood preservative oil stain or solid hide latex stain.

- Top Quality
- Satisfaction Guaranteed

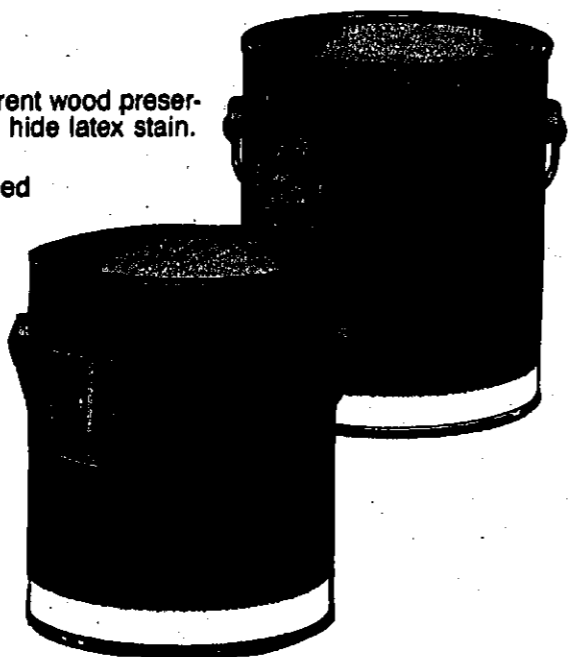

999
Reg. \$14.99

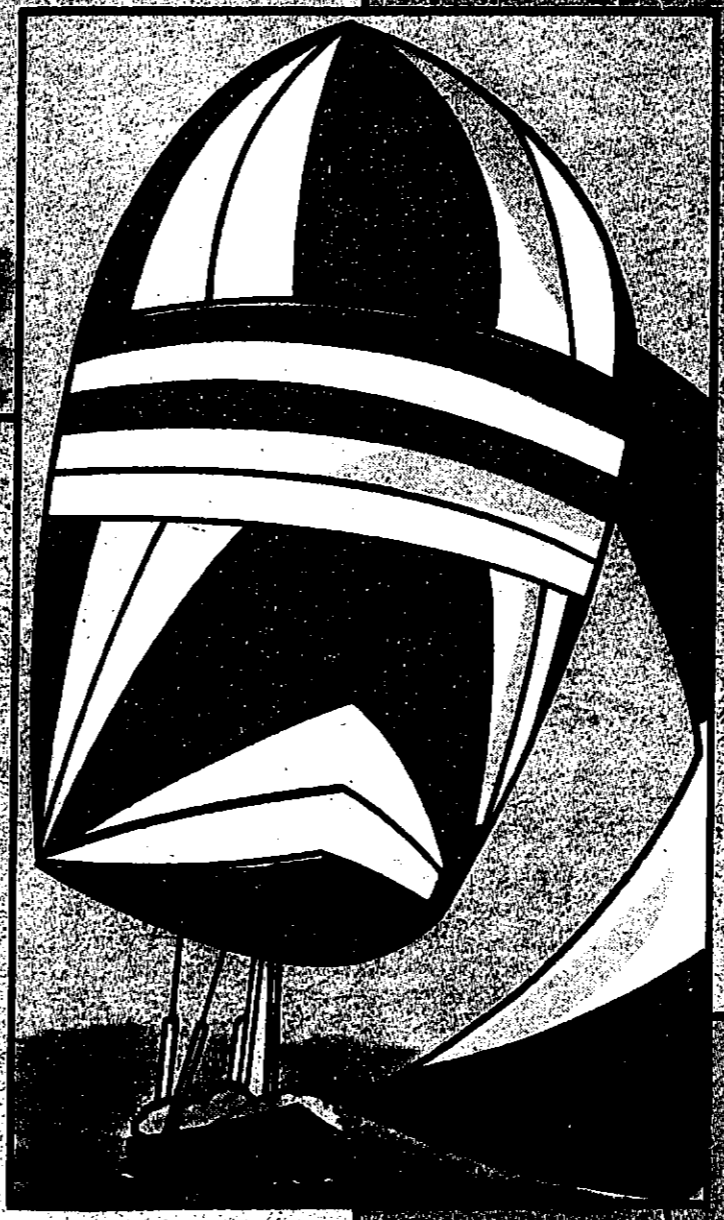

**PINE
CASHWAY
LUMBER**

**WE WILL NOT
BE UNDERSOLD!**

Bring in any competitor's current ad and we guarantee to match the advertised price on the identical in-stock item. Cash & carry sales only. No sales to dealers.



**ALL DECKED OUT WITH PRESERVATIVE
PRESSURE-TREATED LUMBER**

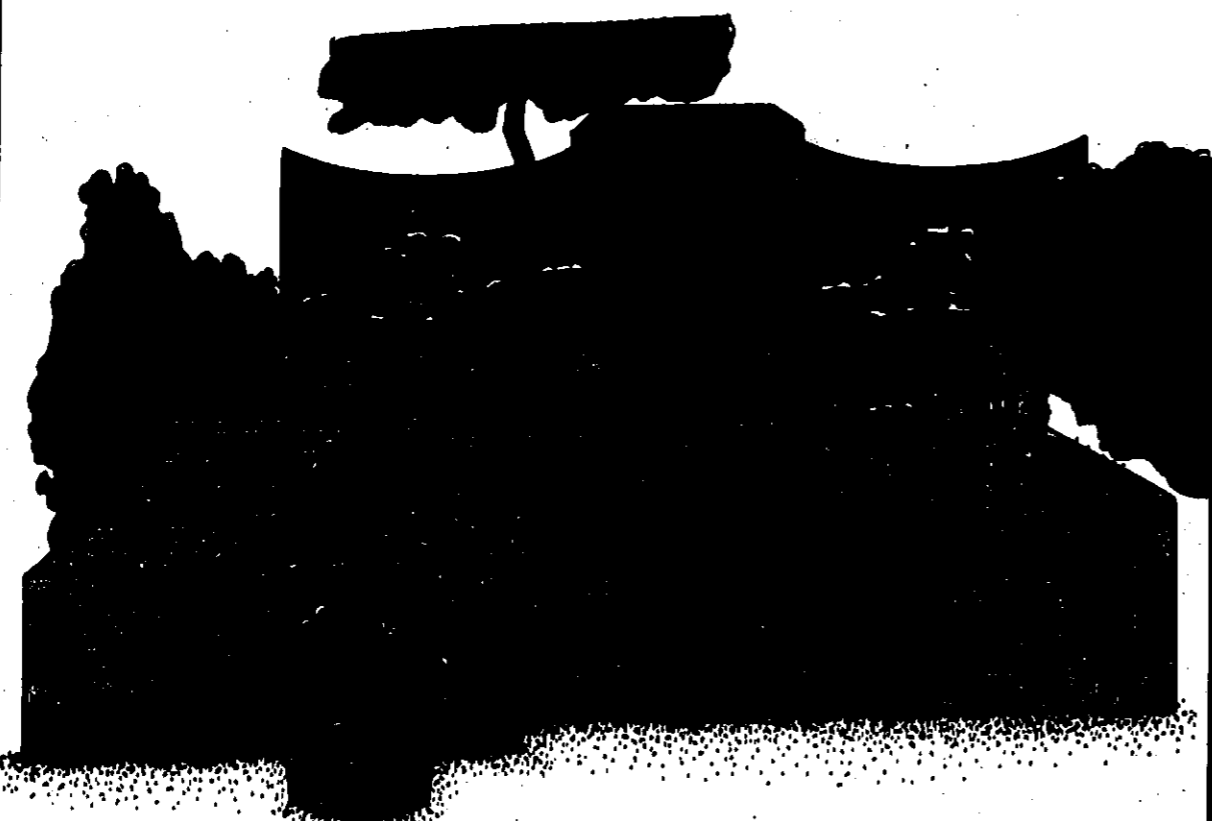

10'x14' DECK ONLY	12'x12' DECK ONLY	16'x16' DECK ONLY
21439	24550	40575

Decks include: pressure-treated posts, joists, beams and 5/4x6 deck boards and nails.

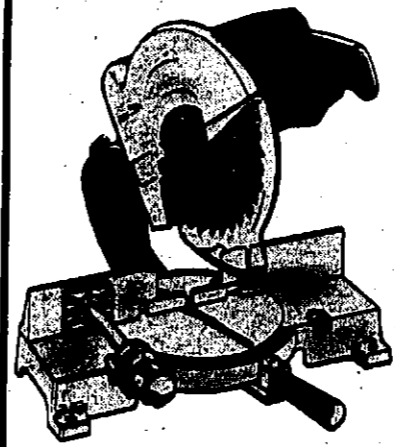

Makita

TABLE SAW

- Powerful 12 amp, 4500 rpm motor
- See-thru blade guard with anti-kick back safety device
- Removable switch key for added safety. #2708

Your
Choice
19900

**POWER MITER
BOX**

- Double insulated
- Powerful 12 amp hi-tech motor •4100 rpm. #LS-1000

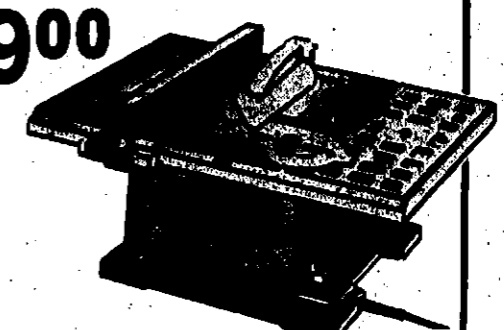

PINE CASHWAY LUMBER

Swings-N-Things

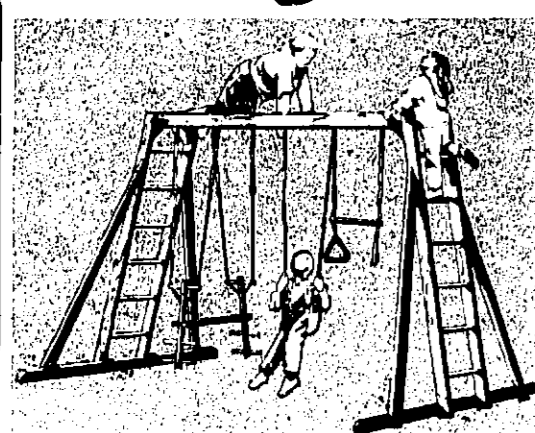

Sturdily designed and constructed for years of outdoor fun. All parts pre-cut; bolt holes pre-drilled. NO cutting or drilling. Kit includes long-lasting, pressure-treated woods; pre-assembled ladders and swing units; all hardware, etc.

Model ST-1
Swings-N-Ladders
269⁹⁵

Model ST-3
Swings-N-Fort
469⁹⁵

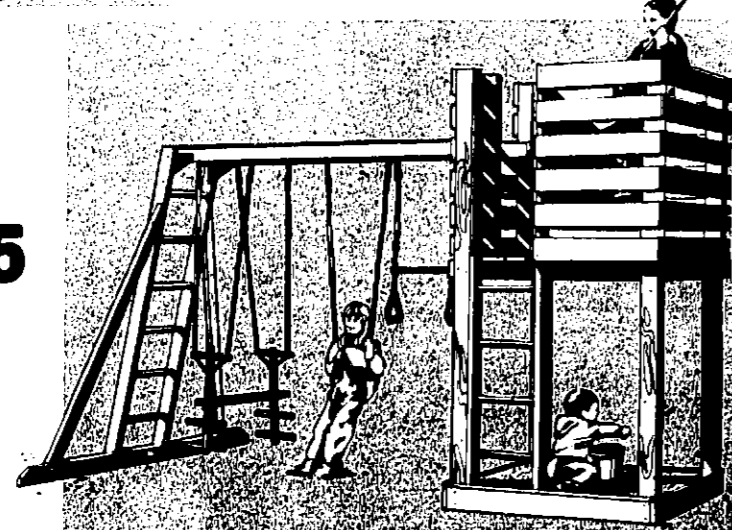

GARDEN HOSES & ACCESSORIES

HOSE HANGER
129

NYLON REINFORCED GARDEN HOSES
5/8" x 50' **599**
5/8" x 75' **899**

OSCILLATING SPRINKLER
Meinor #GN61
499

PISTOL GRIP HOSE NOZZLE
#4324
179

FAN SPRAY NOZZLE
#4321
199

SPIKE SPRINKLER
#6207
695

CEMENT, MORTAR & SAND

Redi-Mix Cement **244** 80 Lb.

Redi-Mix Mortar **244** 80 Lb.

Play Sand **199** 50 Lb.



ornyte FIBERGLASS PANELS

WEATHERTUF
Green, white or yellow.

26" x 96" **485**
26" x 120" **595**
26" x 144" **725**

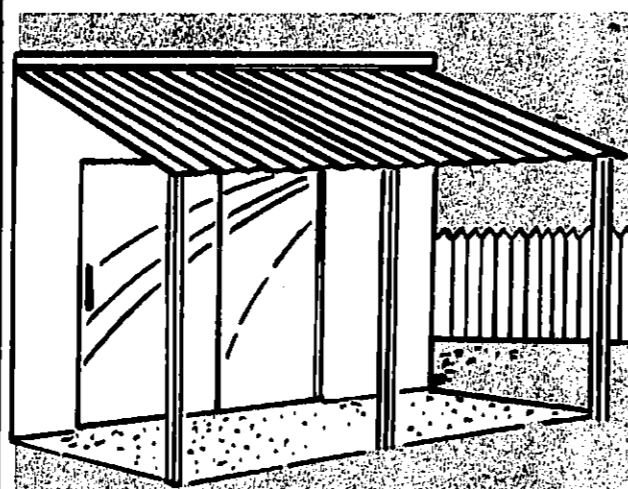

SOLAR GRO
Build your own greenhouse.

26" x 96" **698**
26" x 120" **865**
26" x 144" **1045**

LAWN & GARDEN TOOLS

WHEELBARROWS

5 cu. ft. **2988** 4 cu. ft. **2388**

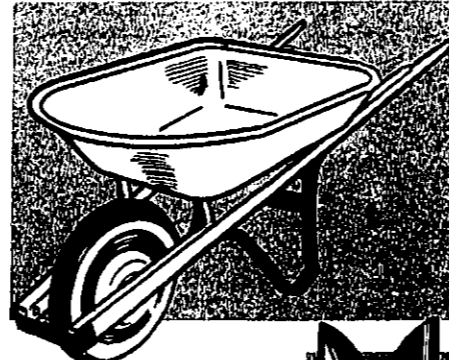

TREE PRUNER
1695 #4146

POST HOLE DIGGER
687

PRUNING SHEARS
#4135 **387**
#4137 **487**

HEDGE SHEARS
#4110 **587**

4 PIECE TOOL SET
#4209 **198**

LOPPING SHEARS
#4111 **487**

GARDEN TOOLS

AMES
LAWN AND GARDEN TOOLS

• Long Handled Square Point Shovel • Garden Bow Rake • Cultivator • Long Handled Round Point Shovel.

Your Choice
695



PINE CASHWAY LUMBER

FIX-UP PROJECTS

PINE CASHWAY LUMBER

GARAGES

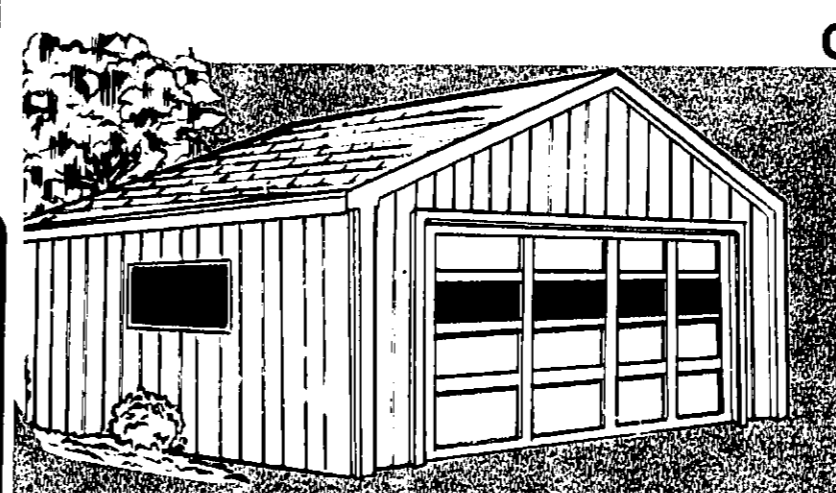

Standard packages include: •Shingles •Nails •2x6 rafters •16" O.C. standard & better lumber •4x8-7/16" structure board roof sheathing •4x8 19/32" rustic T-1-11 fir siding.

20'x20' STANDARD PKG. **\$949** 22'x22' STANDARD PKG. **\$1089** 24'x24' STANDARD PKG. **\$1229**

Deluxe packages include: •Shingles •Nails •Engineered roof trusses •16" O.C. standard & better lumber •4x8 7/16" structure board roof sheathing •4x8 19/32" rustic T-1-11 fir siding •Aluminum window •Pre-hung service door with key lock •Drip edge.

20'x20' DELUXE PKG. **\$1199** 22'x22' DELUXE PKG. **\$1319** 24'x24' DELUXE PKG. **\$1499**

(Overhead door not included - but available.)

DELUXE BARN KITS

You've got it made with Parrott overlay patterns. Kit comes complete with shingles, fir siding, nails, hardware and templates that make it an easy do-it-yourself job. Available in almost any size to fit your need.

8'x8' KIT
\$255

10'x12' KIT
\$395

12'x16' KIT
\$535

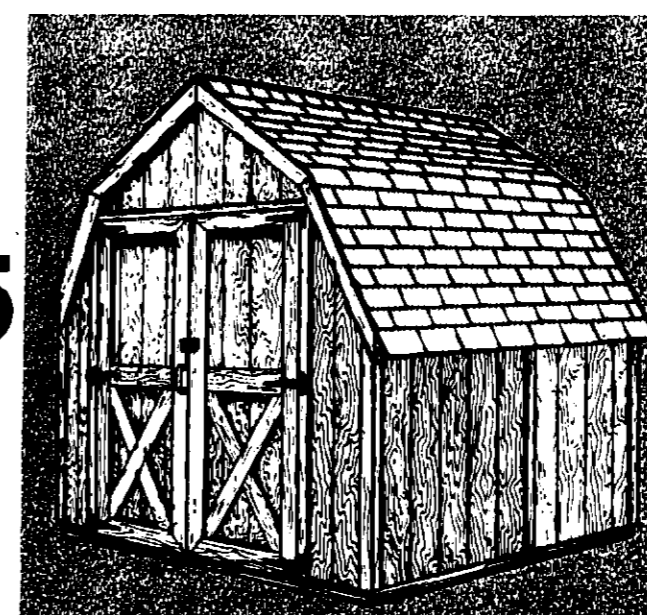

EASY-UP

SAWHORSE KIT
•Sturdy-made from high quality construction lumber •Assembles in seconds •Legs fold up for easy storage.

495 #599972

VINYL GUTTER

•Strong, durable-won't scratch or dent •Never rusts, rots or corrodes •never needs painting •Snaps on tight...won't leak.

Brown or White 10' Gutter

378 #581739

RAIN MASTER

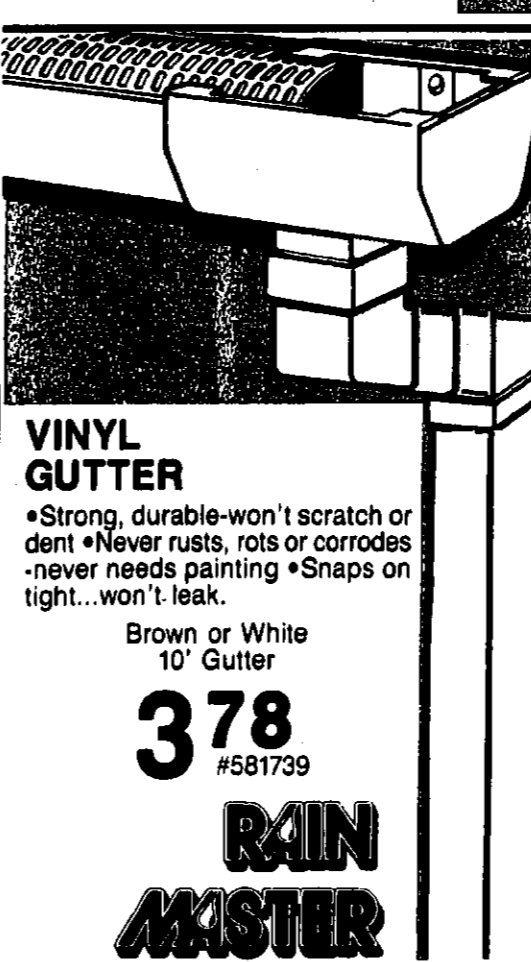

CertainTeed

GLASSGUARD® ASPHALT SHINGLES

•20 year limited warranty
•7 popular colors
•U.L. class "A" fire rating
•Self-sealing, U.L. rated for wind resistance

699 BDL.

\$20.97 sq.

WE WILL TAKE 5% OFF ANY CURRENTLY ADVERTISED LOWER PRICE

for #1 grade shingles. Bring in the ad - and save! Cash & carry only. Quantities limited to normal household use.

Glassguard® is an asphalt shingle with a high-tech glass mat.

POLE BUILDINGS



Economy packages include galvanized steel and professional blueprints. Standard packages include painted steel, prehung service door and professional blueprints.

20'x24'x8' Economy Package
\$1199

24'x32'x8' Economy Package
\$1679

20'x24'x8' Standard Package
\$1579

24'x32'x8' Standard Package
\$1999

24'x32'x10' Standard Package
\$2199

30'x40'x8' Standard Package
\$2759

30'x40'x10' Standard Package
\$2959

30'x56'x10' Standard Package
\$3699

30'x64'x10' Standard Package
\$4099

40'x64'x10' Standard Package
\$5599

40'x64'x12' Standard Package
\$5999

40'x80'x12' Standard package
\$6999

60'x64'x14' Standard Package
\$9999

EZ BREEZE™ WHOLE HOUSE CENTRAL FAN

•Quick and simple to install •Mounts in attic or wall •Permanently lubricated •No maintenance •Variable speed •Shutters included.

1/4 H.P. - 24" #598917

139⁹⁵

1/2 H.P. - 30" #598909

159⁹⁵

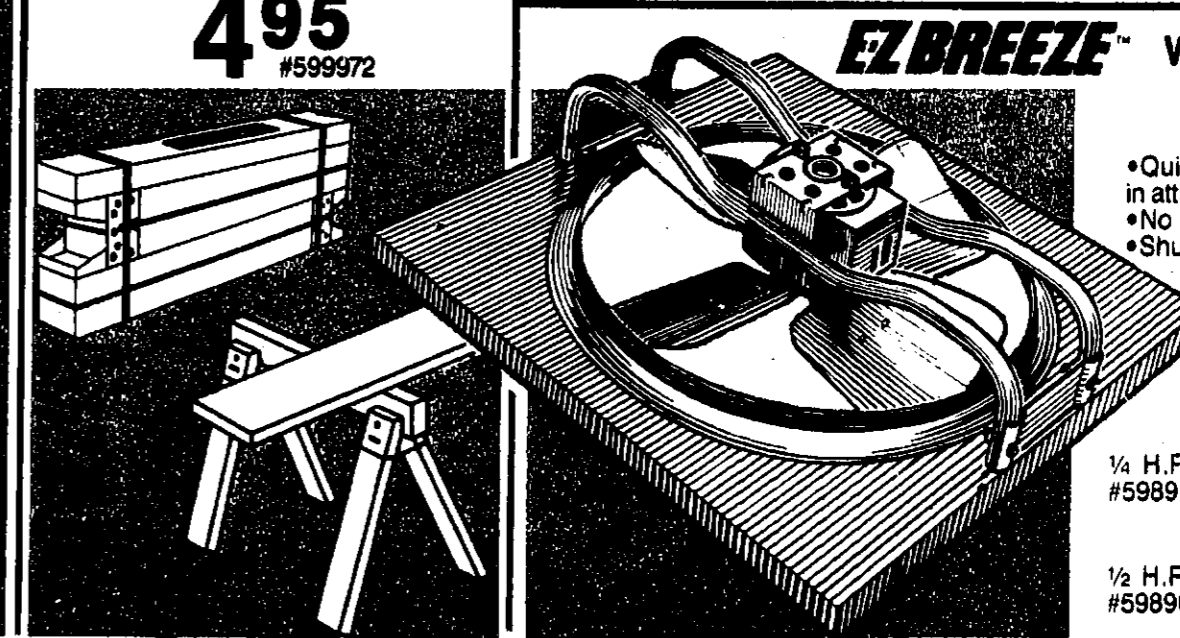

**PINE
CASHWAY
LUMBER**

ENJOY THE GREAT OUTDOORS

**PINE
CASHWAY
LUMBER**

SWING GLIDER

Easy to assemble kit includes all lumber and hardware needed to make this attractive 5 ft. patio glider.



5675
With Treated Lumber 5995

PICNIC TABLE

Heavy construction with frame and five 2x10-8'.

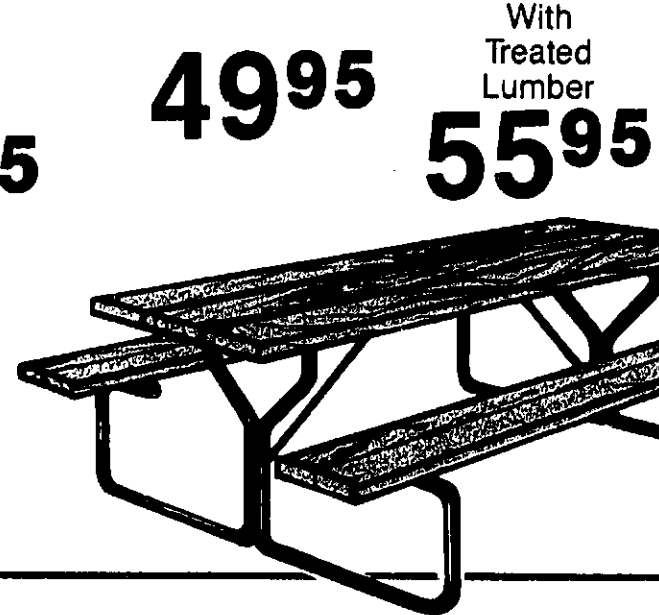

4995
With Treated Lumber 5595

PATIO FURNITURE GENESIS COLLECTION

5 Pc. Set 18995

Includes: 4 chairs and fiberglass table. Priced separately:
Chairs \$44.95
Fiberglass Table \$64.95
Textaline Umbrella \$69.95
The Genesis Group can also be purchased with a glass top table — priced separately at \$79.95

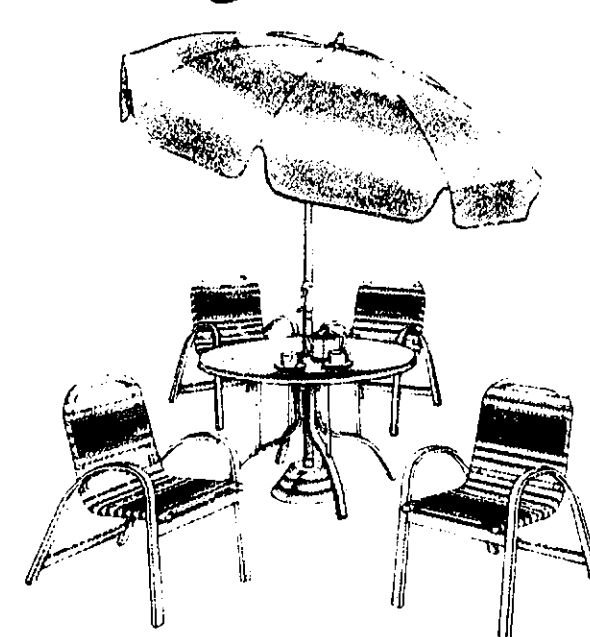

FIAM LOUNGE CHAIR

The ultimate in backyard seating! This cloth chair has multiple positions for cool, summer relaxation.

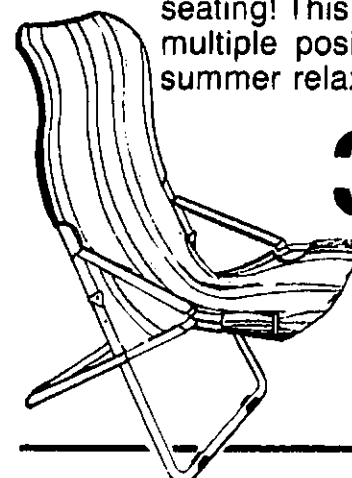

3995

P.V.C. COLLECTION

5 Pc. Set 27975

Includes: 4 chairs and fiberglass table. Priced Separately:
Chairs \$64.95
Fiberglass Table \$74.95
Textaline Umbrella \$69.95

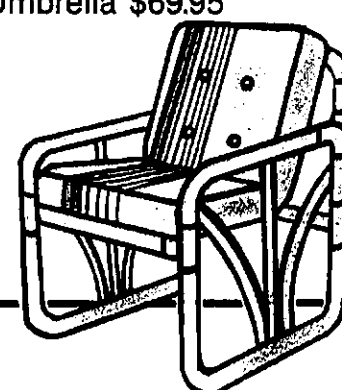

A YEAR 'ROUND INDOOR-OUTDOOR PLAYHOUSE!

•Easy to assemble... everything is pre-cut •Features window grilles, shutters, half door and flower box •60" wide x 48" deep x 54" high.

10995

KID-RABIN

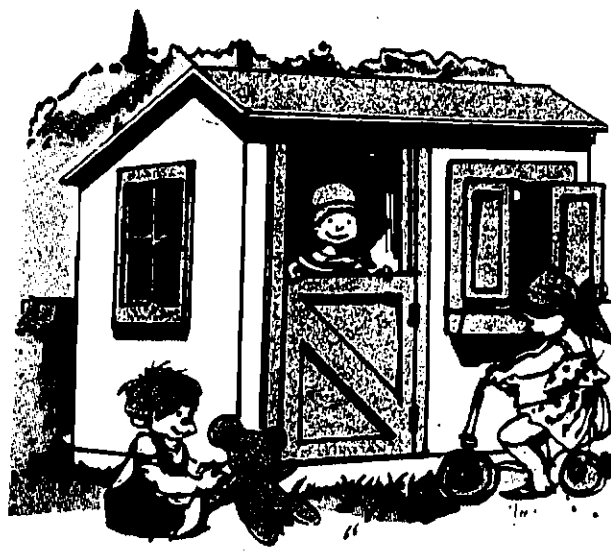

STOCKADE FENCE

#2054 Spruce 6'x8' 1799

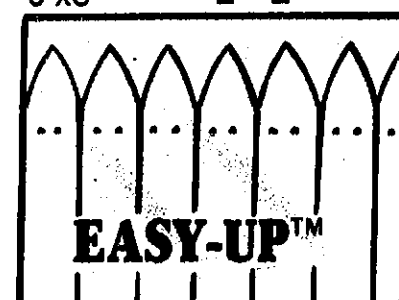

DOG-EAR FENCE

#583340 Pressure-Treated 6'x8' 2699

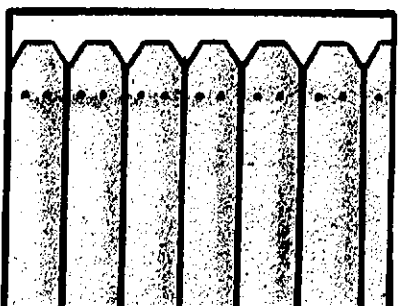

CONCAVE SHADOWBOX

#606618 Pressure-Treated 6'x8' 3395

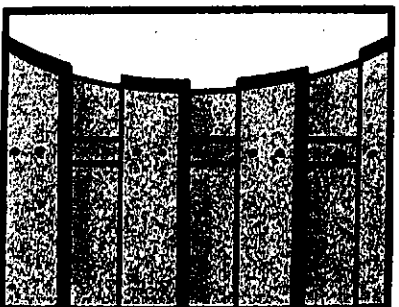

CONVEX SHADOWBOX

#606596 Pressure-Treated 6'x8' 3395

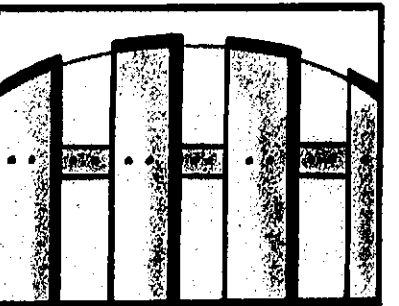

LATTICE PANELS

Pressure-Treated. 24x96 48x96 699 1295



ALL DECKED OUT WITH PRESERVATIVE PRESSURE-TREATED LUMBER!

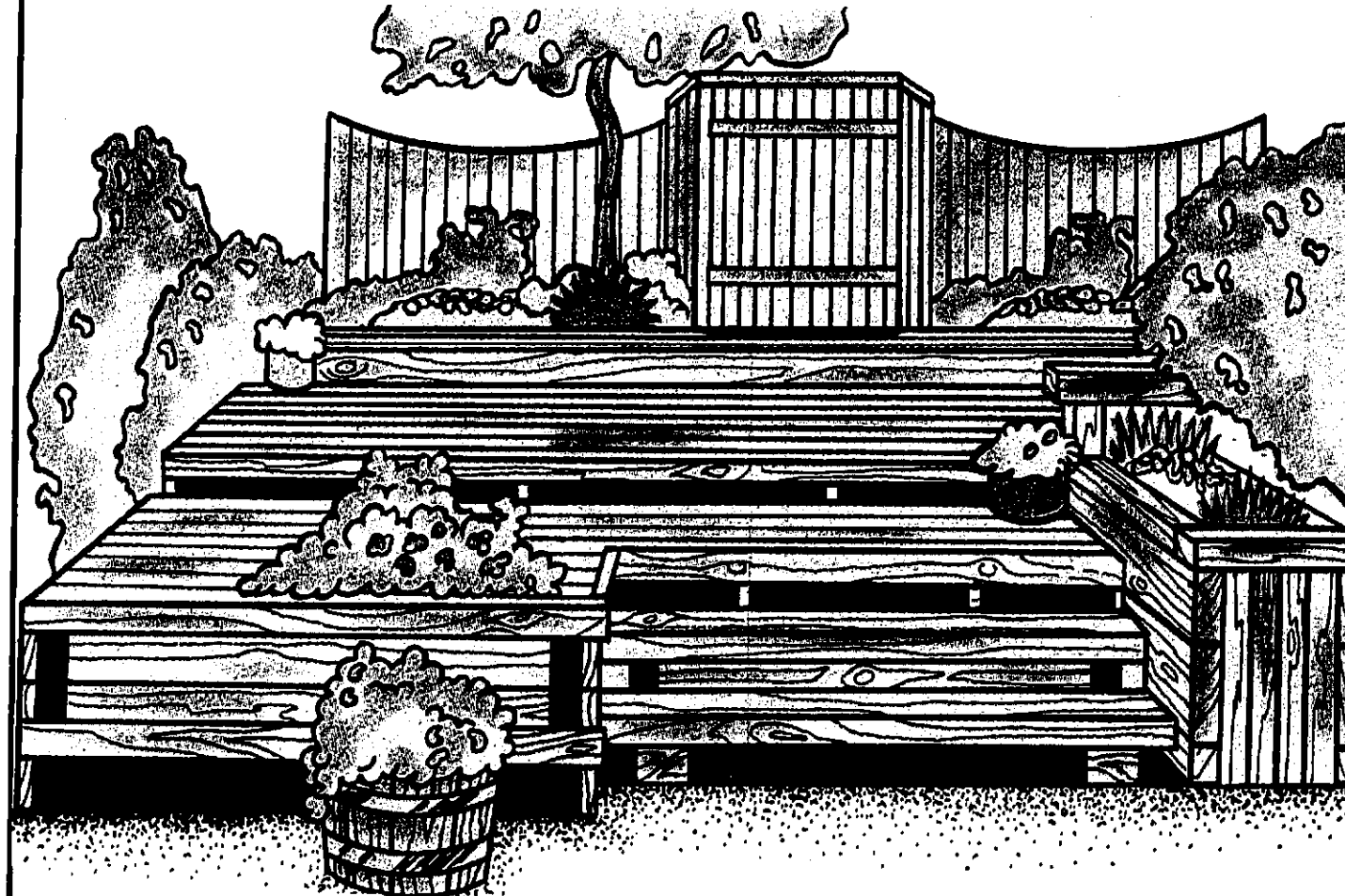

10'x14' DECK ONLY 21439
12'x12' DECK ONLY 24550
16'x16' DECK ONLY 40575

Decks Include: Pressure-Treated posts, joists, beams and 5/4x6 deck boards and nails.

	8'	10'	12'	14'	16'
2x4	2.19	2.79	3.59	3.99	4.99
2x6	3.49	4.39	5.69	6.75	7.69
2x8	4.49	5.69	7.99	8.89	9.95
2x10	5.99	7.89	9.95	11.85	13.55
2x12	7.95	10.25	12.95	14.39	16.95
4x4	3.99	5.99	7.19		

TREATED DECK BOARDS

Exclusive! Select quality — it was manufactured for us — the grade was picked by us. We're so proud of this lumber, we put our name on it. 30 year guarantee.

8 Ft. 309 10 Ft. 379 12 Ft. 459
14 Ft. 539 16 Ft. 619

TREATED BOARDS

Make your own fence — repair your eaves — dozens of uses, with long-lasting results.

1x4 21¢ Lin. 1x6 32¢ Lin.
2x2 19¢ Lin.

CYPRESS MULCH

For landscaping or garden trim. #583286 229

DuPont Landscape Fabric

For healthier plants with less work. •Impedes weed growth •Lets water pass through to thirsty plant roots •Chemically inert.
3'x50' 988 3'x100' 1888



4 FT. DECK RAILING POSTS

4"x4"x4 ft. Pressure treated. #606553 339

PINE BARK NUGGETS

For landscaping or garden trim. #607630 299 3 Cu. Ft.

BASKETWEAVE

#606626 Pressure-Treated 6'x8' 3295

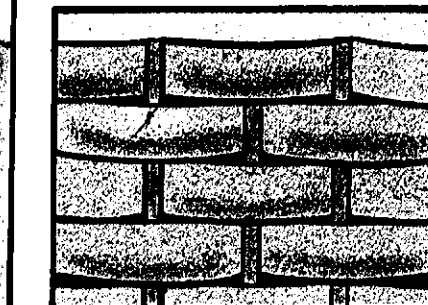

MODIFIED FRENCH GOTHIC FENCE

#606588 Pressure-Treated 6'x8' 2799

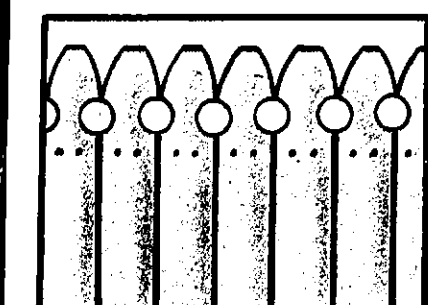

SPACED PICKET FENCE

#583332 Spruce 42"x96" 995

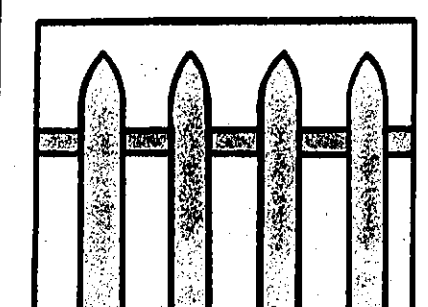

FRENCH GOTHIC RANDOM SPACED PICKET TREATED

42"x96" 1195

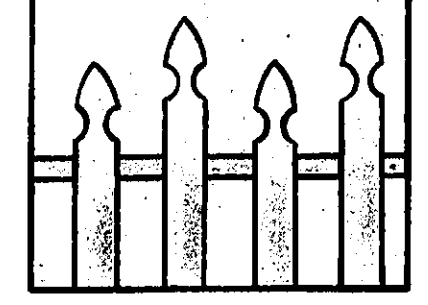

CEDAR SPLIT RAIL FENCE

8 ft. section includes: One post and two 8 ft. rails. 1295

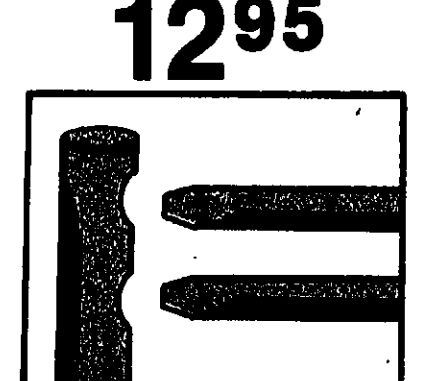

Pay Dirt Tarp

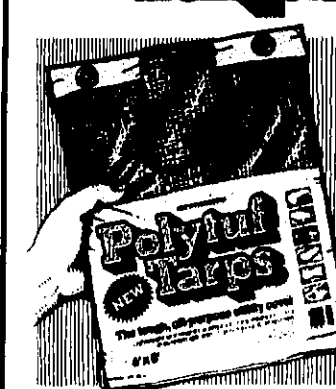

3'x18' 299
6'x8' 399
8'x10' 499
9'x12' 699
12'x14' 999
10'x18' 1099

•Rugged woven polyethylene fabric laminated with polyethylene film. •Grommets every three feet with rope sewn into hem for added strength. •For boats, cars, furniture, machinery and more.

STO-A-WAY

Easy-to-assemble complete kit, 24"x48"x36" high. Use a Sto-A-Way for:
•Garbage cans
•Grill accessories
•Lawn and garden tools
...or general storage anywhere!

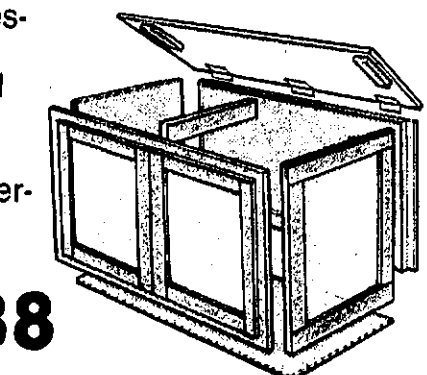

5688

TREATED DECK SQUARES

Build a walkway, a patio or an entire deck with CCA pressure treated deck squares.

32"x32" 995 Each #606634

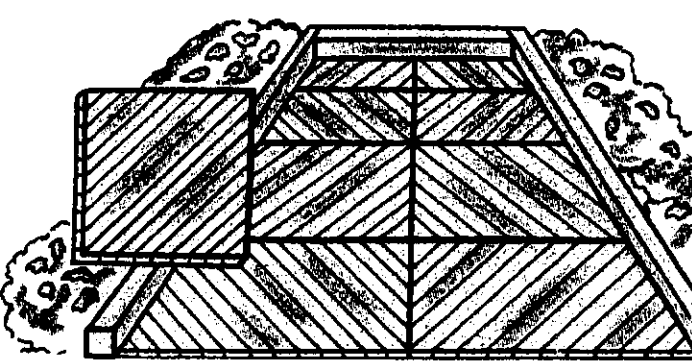

PATIO BLOCKS

•Slate finished tops •Self spacing •No mortar or tools required.

Canyon STONE

12"x12" 149
16"x16" 249
24"x24" 449

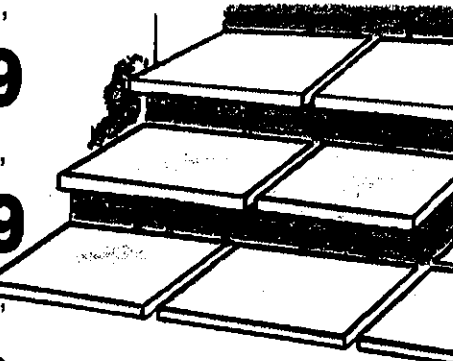

WHISKEY BARRELS

Oak half barrels. Perfect for planters or garden furniture. 695 #587923

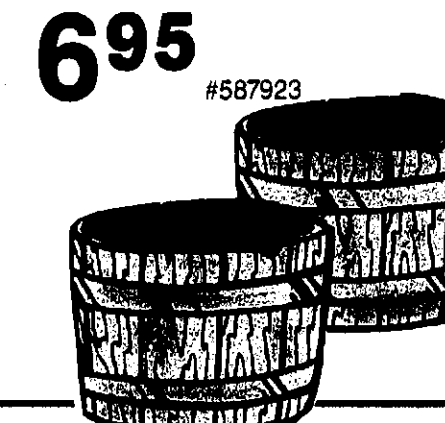

LANDSCAPE TIMBERS

Rough sawn. Preservative, pressure-treated.

4x4-8' 359
3x5-8' 519
4x6-8' 849
6x6-8' 1159

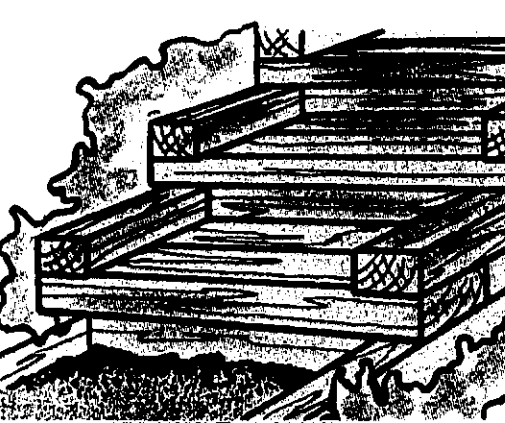

HANDY HUT

Easy-to-assemble, complete kits. •Everything is pre-cut... nothing to saw •Doors are pre-assembled and pre-hung. •Handy hangers automatically align frame.

8'x8' Kit 19900 #583529
10'x12' Kit 39900 #583510

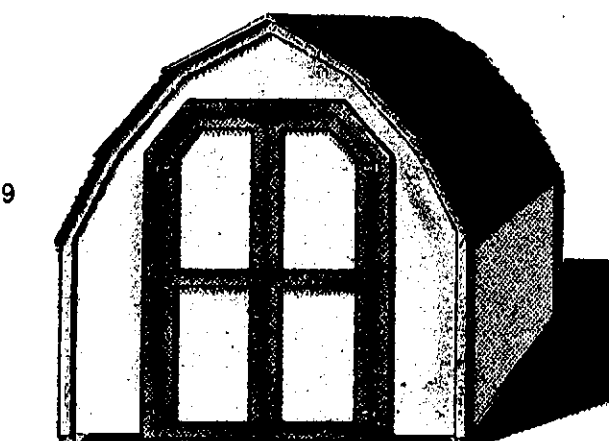

PINE CASHWAY LUMBER

REPAIR-REDO

PINE CASHWAY LUMBER

POWER TOOLS

Skil Twist
CORDLESS SCREWDRIVER
 • 1/4" hex collet • Phillip/slotted bit included • Stores in handy recharging stand.
1999 #2105

SKIL
CORDLESS DRILL/SCREWDRIVER
 • 230 RPM/Reversible • 3 hour recharge • Charging stand with bit storage to keep tool always ready.
3499 #2125-02

SKIL
CORDLESS DRILL KIT
 • Solid state electronic variable speed control • Recharges in 1 hour or less • Fits custom carrying case and extra power pak included.
10494 #2725-02

SKIL
7 1/4" CIRCULAR SAW
 • Powerful, high torque motor, 2 1/8 H.P., 4600 RPM • Textured front and rear handles
3995 #5150

SKIL
3/8" VARIABLE SPEED, REV. HAMMER DRILL
 • Two tools in one-variable speed drilling action 0-2,600 rpm and 1-40,000 bpm for concrete and masonry hammering.
3695 #6425

SKIL
BELT SANDER
 • 3"x18" belt, 3/4 h.p. • Dust bag dust collector • Large 15 3/8 square inch sanding pad.
4999 #7313

SKIL
VARIABLE SPEED JIGSAW
 • 30 amp, 1/2 h.p. • Variable speed 0-3200 spm • 0-45° foot tilts left or right.
3499 #4235

Makita

Makita
CORDLESS DRILL W/FLASHLIGHT
 • Kit includes rechargeable drill and flashlight, plastic tool case, chuck key, philips bit, drill chuck, charger and battery.
8888 #6010 DL

Makita
CORDLESS JIG SAW
 • 2700 spm for fast, smooth cutting action • Powerful 9.6 vdc one hour fast charge battery with automatic cut-off charger.
8888 #4300 DW

winter seal OF FLINT INC.
WINDOWS
 • Quality certified • FHA approved thermal break • Maintenance free • Simple installation • No storm windows needed.
NOW 40% OFF

SIZE	LIST	SALE
3/0-2/0	102.23	61.34
3/0-3/0	130.38	78.23
4/0-3/0	154.14	92.48
4/0-4/0	191.73	115.04

Sale prices include screen. All other stock units at similar savings.

THE ORIGINAL ATRIUM DOOR
 A beautiful and logical alternative to aluminum siding doors! • 3/4" glass and thermal break saves energy • Self-draining oak sill • For replacement or new construction • Includes screen and solid brass mortice lock • #581674, 6/0x6/8
53900
 (Grills not included)

POWER TOOL ACCESSORIES

VERMONT AMERICAN
7-7/8" CARBIDE BLADE
 • 16 Tungsten Carbide teeth
399

SABER SAW BLADES
3 PIECE CIRCULAR SAW BLADE SET
 Includes: cut off/rip blade, chisel tooth blade & plywood panel blade.
129 #30034
499 #26406

PINE CASHWAY LUMBER

REMODEL-RENEW

PINE CASHWAY LUMBER

LATEX WALL PAINT PRIMER
 Promotes adhesion of top-coat. For use on wallboard, plaster, sheetrock, masonry, wood and primed metal.
969 2 Gal.

SAVE \$121
WHITE LATEX WALL PAINT
 For use on wallboard, plaster, sheetrock, masonry, wood and primed metal.
478 Gal. Reg. \$5.99

SAVE \$300
SATIN FLAT LATEX ENAMEL
 • Playroom tough and living room beautiful • Spatter resistant • Easily washable.
999 Gal. Reg. \$12.99

SAVE \$400
SATIN TONE SEMI-GLOSS LATEX ENAMEL
 • Wipe clean beauty is easy to use finish for walls and trim.
1299 Gal. Reg. \$16.99

SAVE \$300
GUARDIAN LATEX HOUSE PAINT
 • Blister resistant • Mildew resistant • Hundreds of colors.
999 Gal. Reg. \$12.99

SAVE \$210
LATEX REDWOOD STAIN
 Renews life in lawn furniture, picnic tables and decks. Water clean-up.
299 Gal. Reg. \$5.09

OLYMPIC STAIN
SEMI-TRANSPARENT
WOOD PRESERVATIVE

white latex Wall Paint

SATIN TONE SEMI-GLOSS LATEX ENAMEL

GUARDIAN LATEX HOUSE PAINT

LATEX REDWOOD STAIN

OLYMPIC STAIN
SEMI-TRANSPARENT
WOOD PRESERVATIVE

WOOD SCREEN DOORS

30" or 32"
2495

36"
2695

EXTERIOR STEEL DOORS

The energy-efficient answer to drafty, ill-fitting entry doors. Already bored for lockset. Prehung in a wood frame.

PLAIN PD-1 32" or 36"
9995

6 PANEL DE-21 32" or 36"
10995

CROSSBUCK DE-51 32" or 36"
15995

White
 32" or 36" Crossbuck
 32" or 36" Traditional
 36" Full-View, Sgl. Glz.
18800

Brown
 32" or 36" Crossbuck
 32" or 36" Traditional
 36" Full-View, Sgl. Glz.
19800

SAVE \$500 SEMI-TRANSPARENT STAIN
 • Real oil stain • Lets color, grain and texture of wood show. Reg. \$17.99 gal. NOW **1299**

SAVE \$500 SOLID OIL STAIN
 • Hides color and grain of new wood. • Penetrates to protect. Reg. \$17.99 Gal. NOW **1299**

SAVE \$500 CLEAR WOOD PRESERVATIVE
 • For all above ground wood • Helps protect against rot, mildew, and moisture damage. Reg. \$13.99 Gal. NOW **899**

MAXIMUM PROTECTION AGAINST THE ELEMENTS . . . RUST-OLEUM PRIMERS AND TOPCOATS

Spray
288

Quart
549

Standard Colors

BUILDING SUPPLIES

	8	10	12	14	16	18	20
2x4	1.29	1.99	2.55	2.95	3.89	4.59	5.09
2x6	2.45	2.99	3.55	4.35	5.29	6.09	7.05
2x8	3.69	4.59	5.65	6.45	7.49	9.09	10.45
2x10	4.79	5.99	7.35	8.75	11.19	12.59	13.99
2x12	6.99	8.65	10.59	11.99	15.79	18.49	18.95

2x4's
Stud Grade
7 Ft. 8 Ft.
99¢ 129
Economy Grade
7 Ft. 8 Ft.
79¢ 89¢

STRUCTURE BOARD
Structural sheathing. APA rated. The smart man's building panel — does most jobs better than plywood and costs less.
4x8-1/4" 4x8-7/16" 4x8-3/4" T&G
399 699 1339

4x8	G.I.S. EXTERIOR GRADE	CDX SHEATHING	PARTICLE BOARD
1/4"	5.99		
3/8"	10.79	9.99	5.15
1/2"	12.95	7.59	5.60
5/8"	16.99	11.99	6.55
3/4"	17.99	15.79	8.45

*All good-one-side plywood is Western Douglas Fir
**Nominal thickness—may be 1/32 less

LAUAN UNDERLAYMENT
4x8-1/4" **619**
(Nominal 1/4")

DRYWALL
4x8-3/8" **439**
4x8-1/2" **439**

JOINT COMPOUND
Joint or topping compound **897** 5 Gal.
DRYWALL PRIMER **969** 2 Gal.

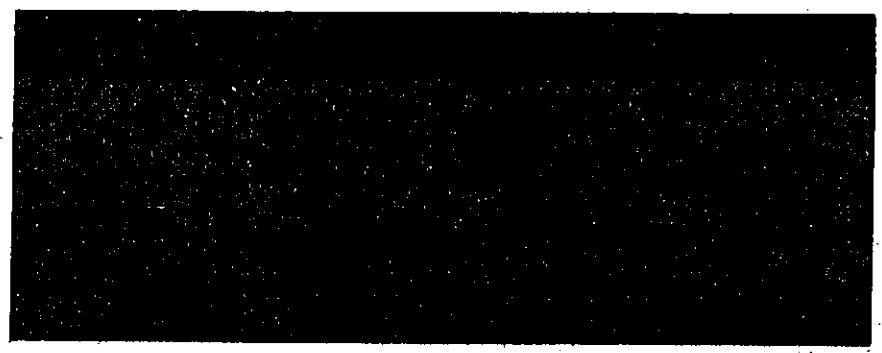

SUPER SPECIAL!
4x8-19/32" Natural Rustic
Tex. 1-11, 8" o.c.
#583197 **1399**

TREATED PLYWOOD
Good-one-side
4x8-1/2" **1495** #588911
4x8-3/4" **1995** #588938

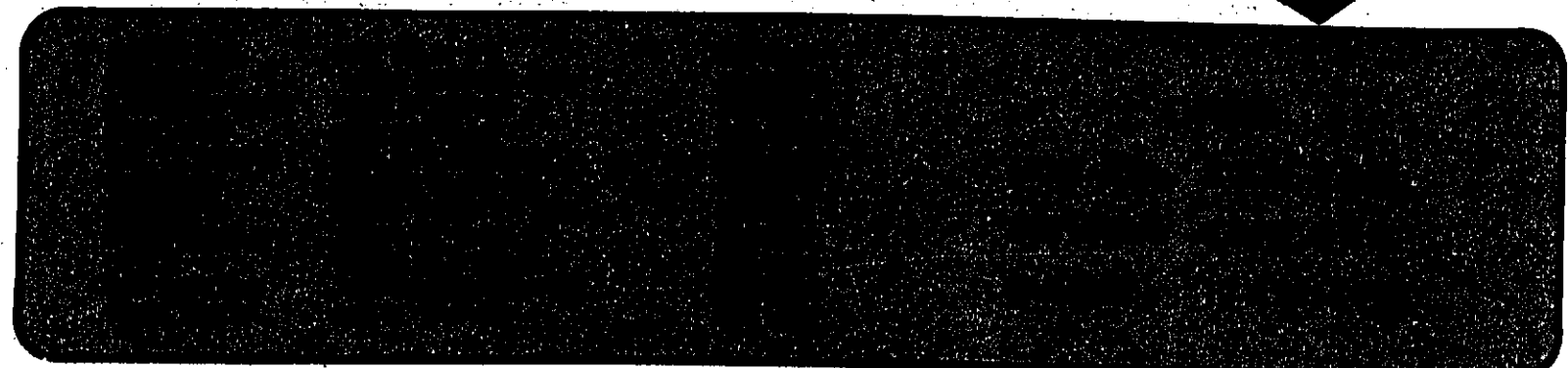
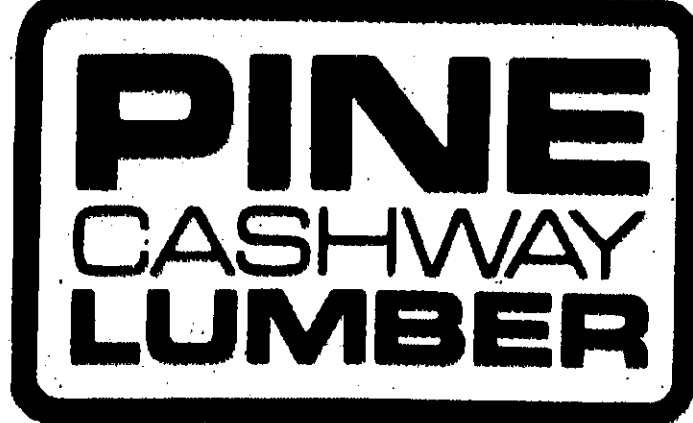
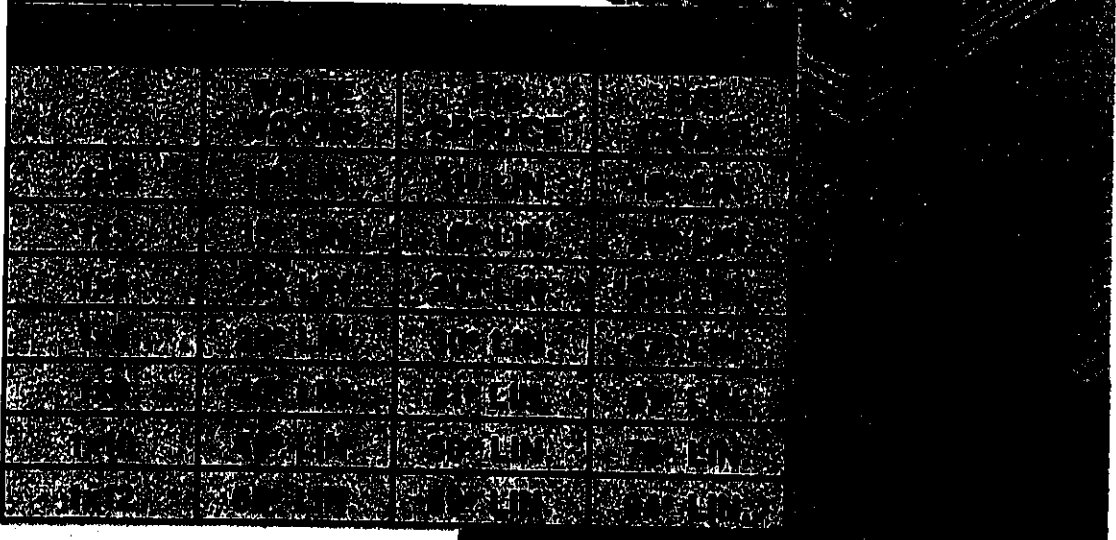

CASH & CARRY PRICES GOOD THRU JUNE 1, 1988
SOME ITEMS MAY NOT BE AVAILABLE AT ALL LOCATIONS. ALL ITEMS CASH & CARRY. NO SALES TO DELAERS.

never knowingly
undersold
Since 1969

drapery-boutique

fashion, selection and
value always at drapery boutique

PULL
OUT SUPPLEMENT
& SAVE



drapery boutique always offers
you exceptional values!

from **20%** to **75%** savings

- Bedspreads • Comforters • Custom draperies • Shower Curtains
- Vertical Blinds • Horizontal Blinds
- Bath Accessories • Towels • Rugs
- Sheets • Wallpaper • Carpeting
- Furniture • etc., etc., etc., and much, much more!

Offer Begins Thurs., May 7, 1986 thru Sat., May 31, 1986

COUPON

Special Order Wallpaper

47% off

47% off 150 selected Special Order books. 40% off all other Special Order books in our library. Coupon must be presented at time of order only. No charges accepted. Min. order \$50.00 at sale price, otherwise discount is only 35%. Freight and Handling added. Offer expires Sat., May 31, 1986. Our library consists of over 1200 Famous books and companies. *WALLPAPER FABRICS 20% OFF

COUPON

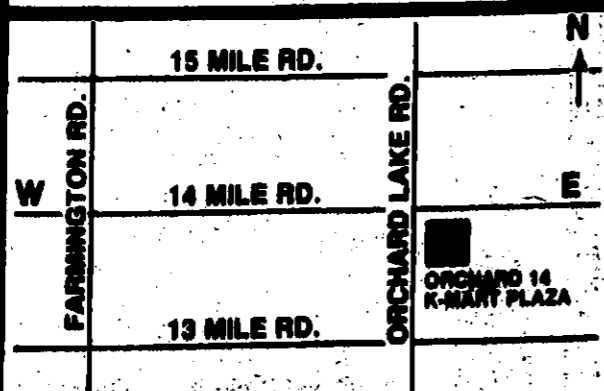

ORCHARD & 14 MILE CENTER

30858 Orchard Lake Road
Farmington
(313) 626-4313
Daily 9:30-6:00
Mon. & Thurs. 9:30-6:00
Open Sun. 12:00-4:00

GRAND RIVER & HAGGERTY Pepper Square

39253 Grand River
Farmington Hills, Pepper Square
(313) 478-3133
Daily 9:30-6:00
Open Sun. 12:00-4:00

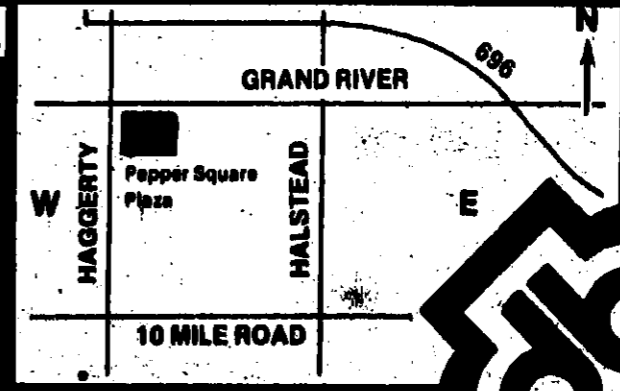

drapery boutique



drapery boutique

never knowingly undersold

Since 1969

we've got your windows covered!

CUSTOM DRAPERIES

SAVE **40% to 63% Off**

on "your choice" in stock fabrics.

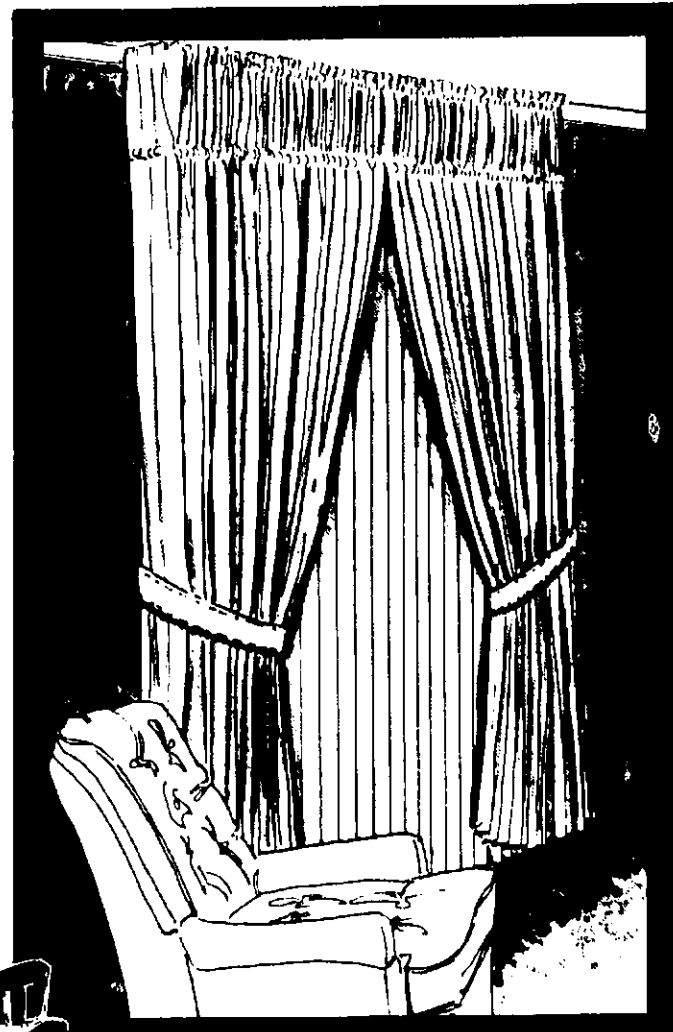

SHEERS

SAVE UP TO **61%**

48" wide Compare **\$388**
\$5.00 to \$10.00 Per Yard Your Choice

ANTIQUE SATINS

SAVE UP TO **57%**

48" wide Compare **\$688**
\$10.00 to \$16.00 Per Yard Your Choice

CASEMENTS

SAVE UP TO **63%**

48" wide Compare **\$888**
\$12.50 to \$24.00 Per Yard Your Choice

DESIGNER PRINTS

SAVE UP TO **65%**

48" to 54" wide Compare **\$1088**
\$15.00 to \$28.00 Per Yard

NO FREIGHT • NO HANDLING CHARGES

HORIZONTAL BLINDS

MICRO 1/2" MINI **67 1/2% OFF**

1" HEAVY DUTY **68% OFF**

1" BALI BLIND **65% OFF**

NO FREIGHT • NO HANDLING CHARGES

custom drapery designs - our specialty!

drapery boutique

ORCHARD & 14 MILE CENTER

GRAND RIVER & HAGGERTY ROADS
Pepper Square Plaza

PLEATED SHADES

Sola-Rite & Louver-Draper

50% OFF PLUS 25% OFF THAT

NO FREIGHT • NO HANDLING CHARGES

Wood Horizontal 1" & 2" Blinds

SAVE **70%**

R.C. Woven Woods
Roman Fold Design

SAVE **50%**

NO FREIGHT • NO HANDLING CHARGES

Window Shades

Fiberglass	SIZE	COMPARE	db	SAVE UP TO
White	37 1/4 x 6	24.00	13 ⁸⁸	47% Cut while you wait!
Ivory	46 1/4 x 6	33.00	17 ⁸⁸	
Champagne	55 1/4 x 6	49.00	25 ⁸⁸	
	73 1/4 x 6	59.00	36 ⁸⁸	

NO FREIGHT • NO HANDLING CHARGES

Scalloped Window Shades

Blackout Insulated Fiberglass	SIZE	COMPARE	db	SAVE UP TO
White	37 1/4 x 6'	35.00	19 ⁸⁸	47% Cut while you wait!
Ivory	46 1/4 x 6'	50.00	27 ⁸⁸	
	55 1/4 x 6'	70.00	37 ⁸⁸	
	73 1/4 x 6'	85.00	45 ⁸⁸	

NO FREIGHT • NO HANDLING CHARGES

CONCORD Horizontal Blinds

SAVE **72% OFF**

Other Custom Sizes at Equal Savings!

Widths up to 112"	NO FREIGHT • NO HANDLING CHARGES					
	23"	29"	36"	48"	62"	72"
Lengths up to 108"	42	17.64	20.44	24.64	30.52	39.48
	48	19.04	22.40	26.88	33.60	43.40
	54	20.72	24.36	29.12	36.40	47.04
	60	22.12	26.04	31.64	39.48	50.96

This chart reflects net prices after 72% discount

never knowingly undersold

drapery boutique

Since 1969

we've got stacks & stacks of Dakota deals!

Scalloped - Ruffled Edge Comforter

Compare **\$200.00** to **\$67.88**
TWIN 275.00 **87.88**
FULL 300.00 **97.88**
QUEEN 340.00 **107.88**

- "Soft Sheen" finish
- Wildflowers quilt design
- Rich decorator colors
- Polyester fiberfill
- Matching pillow shams & dust ruffles available at savings!

Solid Color Elegance!

S.T. DIAGON BEDSPREAD

Compare **\$135.00** to **\$67.88**
TWIN 200.00 **89.88**
FULL 235.00 **97.88**
QUEEN 270.00 **115.88**

SAVE UP TO **56%**

"WINDROWS" BEDSPREADS & COMFORTERS

Compare **\$225.00-250.00** to **\$69.88-99.88**
TWIN \$225.00-250.00 **\$79.88-99.88**
FULL \$275.00-300.00 **\$109.88-119.88**
QUEEN \$300.00-325.00 **\$119.88-129.88**
KING \$350.00-375.00

Duvet Comforter Covers

Available in stock, Twin, Full, Queen, King Sizes in assorted solids & designs

"MELODY" FLORAL DESIGN BEDSPREADS & COMFORTERS

Compare **\$225.00-250.00** to **\$79.88-89.88**
TWIN \$225.00-250.00 **\$89.88-99.88**
FULL \$275.00-300.00 **\$99.88-109.88**
QUEEN \$300.00-325.00 **\$109.88-109.88**
KING \$350.00-375.00

REFLECTIONS COMFORTER

Compare **\$180.00** to **\$59.88**
TWIN 220.00 **73.88**
FULL 250.00 **83.88**
QUEEN 275.00 **89.88**
KING

• Matching Pillow shams & dust ruffles available at savings.

Solid Color Elegance

our values on comforters are superb!

ORCHARD & 14 MILE CENTER

drapery boutique

GRAND RIVER & HAGGERTY ROADS
Pepper Square Plaza

never knowingly undersold

drapery-boutique

Since 1969

we've gotcha covered on vertical blinds

COMMERCIAL BIDS for Vertical & Horizontal Blinds and Draperies. Please call 855-5144 ask for Mr. Bob Pettito.

Vertical Blinds

Compare our Quality, Selection, Service and Price before buying. BECAUSE NOT ALL VERTICAL BLINDS ARE CREATED EQUAL

SAVE UP TO **75%**

NO FREIGHT NO HANDLING CHARGES

Discount	75% Off	75% Off	75% Off	75% Off	75% Off	75% Off
Pattern & Style	Shade Cloth	Canada	Kirk	Sunlite	Granite	Cedar
Width & Height	Compare	db	Compare	db	Compare	db
47 x 48 1 Way	163.00	40⁷⁵	191.00	47⁷⁵	191.00	47⁷⁵
72 x 84 1 Way	313.00	78²⁵	416.00	104⁰⁰	416.00	104⁰⁰
109 x 84 1 Way	465.00	116²⁵	623.00	155⁷⁵	623.00	155⁷⁵
100 x 84 2 Way	422.00	105⁰⁰	568.00	142⁰⁰	568.00	142⁰⁰
119 x 84 2 Way	495.00	123⁷⁵	667.00	166⁷⁵	667.00	166⁷⁵
84" W x 84" H one way draw fits 6' doorway	Compare \$360.00 db	\$89⁸⁸	Compare \$483.00 db	\$120⁷⁵	Compare \$483.00 db	\$120⁷⁵
			Compare \$483.00 db	\$120⁷⁵	Compare \$483.00 db	\$98⁷⁵
				Compare \$395.00 db	Compare \$395.00 db	\$98⁷⁵

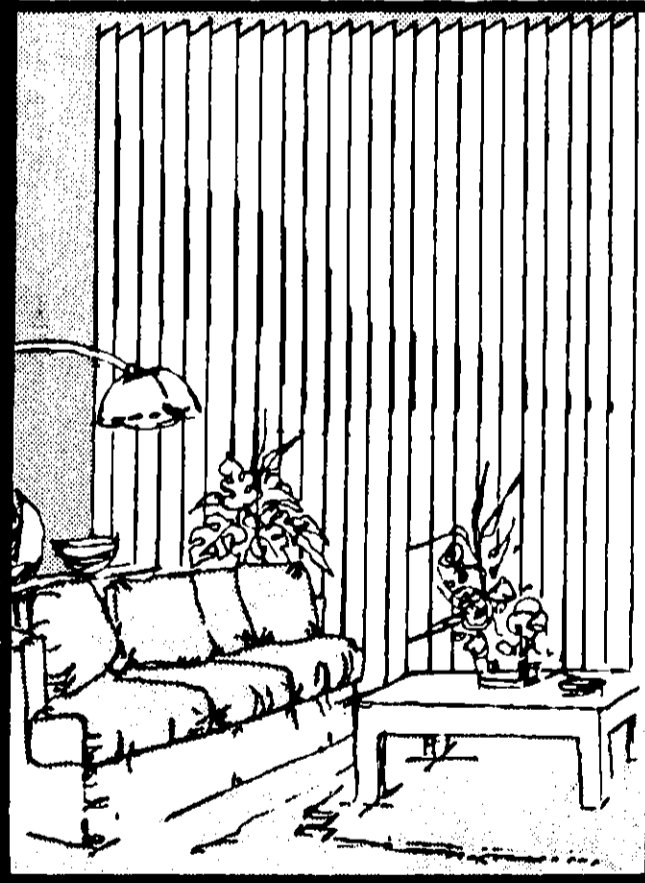

ALL OTHER CUSTOM SIZES AT EQUAL SAVINGS

Compare our Quality, Selection, Service and Price Before Buying...because... There are NO FREIGHT or HANDLING Charges

Heavy Duty Tracking System with self-aligning clutch memory system with a 60 month limited warranty.

Visit our unique Design Studio - our huge selection of Vertical Blind louver materials will meet your desired window decor with direct factory savings!



Vertical Blinds fit Doorwalls and Windows

Measuring, Installation & Design Service at Nominal Charge

NO FREIGHT • NO HANDLING CHARGES

CUSTOM VERTICAL BLINDS 2" Wide Vanes

Selected: •P.V.C. •Aluminums •Decorator Shade Fabrics

the look of drapery - the new fashion accent!

SAVE UP TO **65%**

SIZE	P.V.C. C-Curve	Aluminum Curve	Shade Cloths
Wd. & Hgt.	Compare	db	Compare
21 x 48 1 W	87.00	30⁴⁵	87.00
35 x 48 1 W	108.00	37⁰⁰	108.00
47 x 48 1 W	136.00	47⁰⁰	136.00
60 x 48 1 W	165.00	57⁷⁵	165.00

ALL OTHER CUSTOM SIZES AT EQUAL SAVINGS

NEW Vertical Blinds SAVE UP TO **75%**

Great Selection Doorwall - 72" wide SIZE 84" W x 84" H Doorwall - 96" wide SIZE 109" W x 84" H

DISCOUNT	72%	75%	73%	75%
Pattern	Capri Fabric	Spicer Fabric	Ribbed Curve P.V.C.	P.V.C. Flat
SIZE	db	db	db	db
84" W x 84" H one way draw left or right fits 6' doorway	1314	88⁰⁰	1395	98⁰⁰
109" W x 84" H one way draw left or right fits 6' doorway	1404	108⁰⁰	1510	127⁰⁰

our values on vertical blinds are superb!

ORCHARD & 14 MILE CENTER

GRAND RIVER & HAGGERTY ROADS Pepper Square Plaza

Fashion with Value Always!

never knowingly undersold

drapery-boutique

Since 1969

we've gotcha covered on vertical blinds

more special values on

custom Vertical Blinds

SAVE UP TO **78%** NO FREIGHT NO HANDLING CHARGES

Aluminum	Macrame	Flat Style P.V.C.			
20 Fashion Colors	10 Elegant Patterns/Colors	White, Ivory, Tan			
SAVE UP TO 78%	SAVE 75%	SAVE UP TO 73%			
NO FREIGHT OR HANDLING CHARGE	NO FREIGHT OR HANDLING CHARGE	NO FREIGHT OR HANDLING CHARGE			
SIZE	ALUMINUM	SIZE	MACRAME	SIZE	P.V.C. FLAT
Width & Height	Compare	db	Width & Height	Compare	db
35 x 84 1 Way	\$123.00	30⁷⁵	47 x 48 1 Way	\$317.00	79²⁵
47 x 84 1 Way	157.00	39²⁵	72 x 84 1 Way	688.00	172⁰⁰
59 x 84 1 Way	190.00	47⁵⁰	97 x 84 1 Way	853.00	213²⁵
72 x 84 1 Way	225.00	49⁸⁸	109 x 84 1 Way	963.00	240⁷⁵
109 x 84 1 Way	333.00	83²⁵	100 x 84 2 Way	865.00	216²⁵
			119 x 84 2 Way	1032.00	258⁰⁰
84" wide x 84" high one way draw fits 6' doorway	Compare \$259.00 db	\$59⁸⁸	84" wide x 84" high one way draw fits 6' doorway	Compare \$750.00 db	\$187⁵⁰
			84" wide x 84" high one way draw fits 6' doorway	Compare \$248.00 db	NOW \$66⁹⁶

ALL OTHER SIZES ARE AVAILABLE AT EQUAL SAVINGS

Compare our Quality, Selection, Service and Price Before Buying...Because... There are NO FREIGHT or HANDLING Charges.

We use a **Heavy Duty Tracking System** with self-aligning clutch memory system with a 60 month limited warranty. Measuring, Installation & Design Service at Nominal Charge.

and we have more and more special values to offer on

custom Vertical Blinds

SAVE UP TO **75%** NO FREIGHT NO HANDLING CHARGES

LOBOS	SHADE CLOTH	SPICER	SHADE CLOTH	S-CURVE P.V.C.	
Unique textured weave		Most famous cloth		The look of draperies	
SAVE 75%		SAVE 75%		SAVE 75%	
NO FREIGHT NO HANDLING CHARGES		NO FREIGHT NO HANDLING CHARGES		NO FREIGHT NO HANDLING CHARGES	
SIZE	LOBOS	SIZE	SPICER	SIZE	S-CURVE P.V.C.
Width & Height	Compare	db	Width & Height	Compare	db
47 x 48 1 Way	\$191.00	47⁷⁵	47 x 48 1 Way	\$172.00	43⁰⁰
72 x 84 1 Way	416.00	104⁰⁰	72 x 84 1 Way	341.00	85²⁵
97 x 84 1 Way	551.00	137⁷⁵	97 x 84 1 Way	449.00	112²⁵
109 x 84 1 Way	623.00	155⁷⁵	109 x 84 1 Way	510.00	127⁵⁰
100 x 84 2 Way	568.00	142⁰⁰	100 x 84 2 Way	462.00	115⁵⁰
119 x 84 2 Way	667.00	166⁷⁵	119 x 84 2 Way	544.00	136⁰⁰
84" wide x 84" high one way draw fits 6' doorway	Compare \$483.00 db	\$120⁷⁵	84" wide x 84" high one way draw fits 6' doorway	Compare \$395.00 db	\$98⁷⁵
			84" wide x 84" high one way draw fits 6' doorway	Compare \$287.00 db	\$71⁷⁵

ALL OTHER SIZES ARE AVAILABLE AT EQUAL SAVINGS

our values on vertical blinds are superb!

ORCHARD & 14 MILE CENTER

GRAND RIVER & HAGGERTY ROADS Pepper Square Plaza

Fashion with Value Always!

drapery-boutique

never knowingly undersold

Since 1969

we've got stacks & stacks of bedcovers!

"SWISHEE" TOSS DECORATIVE PILLOWS
25 COLORS

Excellent for sofas, chairs, or beds, in rich high fashion decorator colors.

18" SIZE \$6.88 ea.
Compare \$16.00

"CAMBRIC" Fabric Comforter

SAVE UP TO 71%

- 100% Cotton Cover
- 830 Thread Count
- Extra Fill
- Reversible Design
- Ecru Hi-Tech Color
- Great Value

Compare \$37.88

32 oz. 149.00
45 oz. 199.00

TWIN FULL/QUEEN KING

Allure Comforters Solid Color - Reversible

Reversible - Deluxe Extra Fill Polyester Fiberfill - Rich Fashion Colors & Designs - Matching Shams & Dust Ruffles Available

COMPARE \$79.00

TWIN 88.00
FULL 119.00
QUEEN 129.00
KING 195.00

SPECIAL SAVINGS!

COMPARE \$32.88
42.88
56.88
59.88

NEW "DYNASTY" Bedspread

COMPARE \$100.00

TWIN 130.00
FULL 170.00
QUEEN 195.00
KING 195.00

COMPARE \$76.88
100.88
130.88
150.88

"ULTRA" "Super Solid" Comforters

Reversible - Deluxe Fill Polyester Fiberfill

COMPARE \$79.00

TWIN \$25.88
FULL/QUEEN \$36.88
KING \$44.88

150 PIECES AVAILABLE

Duvet Comforter Covers

Outline Quilted
Uniquely designed
7 oz. polyester fiberfill
Hi-tech colors.
Solid Colors

Available in Twin, Full, Queen, King
In assorted styles and colors.

our values on comforters are superb!

ORCHARD & 14 MILE CENTER

drapery boutique

GRAND RIVER & HAGGERTY ROADS
Pepper Square Plaza



drapery-boutique

never knowingly undersold

Since 1969

bath decor and "necessary accents"

<p>Cannon Royal Family of fine quality</p> <p>Terry Towels</p> <ul style="list-style-type: none"> • Super Values • Fashion Colors <table border="1"> <tr><th>Compare</th><th>db</th></tr> <tr><td>Bath \$10.00</td><td>\$4.88</td></tr> <tr><td>Hand 7.00</td><td>3.88</td></tr> <tr><td>Wash 3.00</td><td>1.88</td></tr> <tr><td>Fingertip N/A</td><td>—</td></tr> <tr><td>Tubmat N/A</td><td>—</td></tr> <tr><td>Bath-Sheet N/A</td><td>—</td></tr> </table>	Compare	db	Bath \$10.00	\$4.88	Hand 7.00	3.88	Wash 3.00	1.88	Fingertip N/A	—	Tubmat N/A	—	Bath-Sheet N/A	—	<p>ROYAL DELITE TERRY</p> <p>Save UP TO 50%</p> <table border="1"> <tr><th>Compare</th><th>db</th></tr> <tr><td>Bath \$12.00</td><td>\$6.88</td></tr> <tr><td>Hand 8.00</td><td>5.48</td></tr> <tr><td>Wash 3.50</td><td>2.48</td></tr> <tr><td>Fingertip 3.50</td><td>2.48</td></tr> <tr><td>Tub Mat 18.00</td><td>12.48</td></tr> <tr><td>Bath-Sheet 30.00</td><td>18.88</td></tr> </table>	Compare	db	Bath \$12.00	\$6.88	Hand 8.00	5.48	Wash 3.50	2.48	Fingertip 3.50	2.48	Tub Mat 18.00	12.48	Bath-Sheet 30.00	18.88	<p>ROYAL CLASSIC TERRY</p> <p>Save UP TO 43%</p> <table border="1"> <tr><th>Compare</th><th>db</th></tr> <tr><td>Bath \$12.00</td><td>\$6.88</td></tr> <tr><td>Hand 8.00</td><td>5.48</td></tr> <tr><td>Wash 3.50</td><td>2.48</td></tr> <tr><td>Fingertip 3.50</td><td>2.48</td></tr> <tr><td>Tub Mat 18.00</td><td>12.48</td></tr> <tr><td>Bath-Sheet 30.00</td><td>18.88</td></tr> </table>	Compare	db	Bath \$12.00	\$6.88	Hand 8.00	5.48	Wash 3.50	2.48	Fingertip 3.50	2.48	Tub Mat 18.00	12.48	Bath-Sheet 30.00	18.88	<p>ROYAL TOUCH SOFT TERRY</p> <p>Save UP TO 47%</p> <table border="1"> <tr><th>Compare</th><th>db</th></tr> <tr><td>Bath \$14.00</td><td>\$9.88</td></tr> <tr><td>Hand 12.00</td><td>7.88</td></tr> <tr><td>Wash 5.00</td><td>3.48</td></tr> <tr><td>Fingertip N/A</td><td>—</td></tr> <tr><td>Tub Mat 21.00</td><td>15.88</td></tr> <tr><td>Bath-Sheet 30.00</td><td>23.88</td></tr> </table>	Compare	db	Bath \$14.00	\$9.88	Hand 12.00	7.88	Wash 5.00	3.48	Fingertip N/A	—	Tub Mat 21.00	15.88	Bath-Sheet 30.00	23.88	<p>Terry 36" x 72" Bath Sheets</p> <ul style="list-style-type: none"> • Super Size 36 x 72 approx. • Assorted Decorator Colors • Thick Terry • Slightly Irregular <p>SPECIAL PURCHASE SUPER-SIZE TOWEL TERRY BOTH SIDES</p> <p>Compare \$24.99</p> <p>\$10.88</p>
Compare	db																																																											
Bath \$10.00	\$4.88																																																											
Hand 7.00	3.88																																																											
Wash 3.00	1.88																																																											
Fingertip N/A	—																																																											
Tubmat N/A	—																																																											
Bath-Sheet N/A	—																																																											
Compare	db																																																											
Bath \$12.00	\$6.88																																																											
Hand 8.00	5.48																																																											
Wash 3.50	2.48																																																											
Fingertip 3.50	2.48																																																											
Tub Mat 18.00	12.48																																																											
Bath-Sheet 30.00	18.88																																																											
Compare	db																																																											
Bath \$12.00	\$6.88																																																											
Hand 8.00	5.48																																																											
Wash 3.50	2.48																																																											
Fingertip 3.50	2.48																																																											
Tub Mat 18.00	12.48																																																											
Bath-Sheet 30.00	18.88																																																											
Compare	db																																																											
Bath \$14.00	\$9.88																																																											
Hand 12.00	7.88																																																											
Wash 5.00	3.48																																																											
Fingertip N/A	—																																																											
Tub Mat 21.00	15.88																																																											
Bath-Sheet 30.00	23.88																																																											
<p>BATH RUGS & WALL TO WALL CARPETS OVAL & OBLONG DESIGNS</p> <p>24 Fashion Decorator Colors UP TO</p> <p>40% OFF RETAIL</p>	<p>"Bonus" Bed Pillow 2 for the price of 1</p> <p>White Polyester Fiberfill Bone China Cover</p> <table border="1"> <tr><th>Standard</th><th>Queen</th><th>King</th></tr> <tr><td>Reg. \$13.00 EA.</td><td>Reg. \$14.00 EA.</td><td>Reg. \$20.00 EA.</td></tr> </table> <p>Standard 2/\$13.88 Queen 2/\$15.88 King 2/\$17.88</p>	Standard	Queen	King	Reg. \$13.00 EA.	Reg. \$14.00 EA.	Reg. \$20.00 EA.	<p>100% Cotton Sheets Designed Sheet Sets*</p> <p>SAVE UP TO 30%</p> <table border="1"> <tr><th>Compare</th><th>db</th></tr> <tr><td>TWIN \$40.00 SET</td><td>\$29.88 SET</td></tr> <tr><td>FULL 65.00 SET</td><td>\$49.88 SET</td></tr> <tr><td>QUEEN 80.00 SET</td><td>\$59.88 SET</td></tr> <tr><td>KING 90.00 SET</td><td>\$69.88 SET</td></tr> </table> <p>*Includes top and bottom sheets & pillow case.</p>	Compare	db	TWIN \$40.00 SET	\$29.88 SET	FULL 65.00 SET	\$49.88 SET	QUEEN 80.00 SET	\$59.88 SET	KING 90.00 SET	\$69.88 SET																																										
Standard	Queen	King																																																										
Reg. \$13.00 EA.	Reg. \$14.00 EA.	Reg. \$20.00 EA.																																																										
Compare	db																																																											
TWIN \$40.00 SET	\$29.88 SET																																																											
FULL 65.00 SET	\$49.88 SET																																																											
QUEEN 80.00 SET	\$59.88 SET																																																											
KING 90.00 SET	\$69.88 SET																																																											
<p>Shower Curtains</p> <p>SAVE UP TO</p> <p>25%</p> <p>VINYLS FABRICS COTTONS</p>	<p>Contemporary Bath Decor Accessories</p> <p>SAVE UP TO 25%</p> <p>art deco design in a rainbow of colors</p> <table border="1"> <tr><th>Compare</th><th>db</th></tr> <tr><td>Wastebasket \$12.49</td><td>\$9.88</td></tr> <tr><td>Tissue Holder 8.99</td><td>6.88</td></tr> <tr><td>Tumbler 2.49</td><td>1.88</td></tr> <tr><td>Soap Dish 3.98</td><td>2.88</td></tr> <tr><td>Combo Toothbrush 7.49</td><td>5.88</td></tr> <tr><td>Soap Dispenser 4.99</td><td>3.88</td></tr> </table>	Compare	db	Wastebasket \$12.49	\$9.88	Tissue Holder 8.99	6.88	Tumbler 2.49	1.88	Soap Dish 3.98	2.88	Combo Toothbrush 7.49	5.88	Soap Dispenser 4.99	3.88	<p>Lamps Lamps Lamps</p> <p>SAVE UP TO</p> <p>50%</p> <p>Styling With Unbeatable Savings!!</p> <p>We have searched and searched to bring the selection of decorator lamps that will please your every possible taste! Along with savings that will please your pocket.</p>																																												
Compare	db																																																											
Wastebasket \$12.49	\$9.88																																																											
Tissue Holder 8.99	6.88																																																											
Tumbler 2.49	1.88																																																											
Soap Dish 3.98	2.88																																																											
Combo Toothbrush 7.49	5.88																																																											
Soap Dispenser 4.99	3.88																																																											

Shop Our Unique Bath Shop For Big Selection & Low Prices

ORCHARD & 14 MILE CENTER

drapery boutique

GRAND RIVER & HAGGERTY ROADS
Pepper Square Plaza



never knowingly
undersold

drapery-boutique

Since 1969

"Bargains Galore"

Wallpaper
Clear
Edge
Guards
4' and 8' sizes
Protect your corners

drapery boutique

drapery boutique COUPON

**Wallpaper
Edge Guards**

4' clear 8' clear
Reg. \$2.99 Reg. \$3.99

\$1.88 \$3.88
ea.

Present coupon at purchase only.
Offer expires Sat., May 31, 1988.

**JUMBO SLEEP
PILLOW**
20" X 29"
SIZE

Compare at \$12.00
GREAT BUY!

- 100% Fortrel polyester
- Fiberfill - hypo allergenic
- Fluffy - odor free

drapery boutique

drapery boutique COUPON

JUMBO SLEEP PILLOW
20" X 29" SIZE

\$6.88
ea.

LIMIT 4

Present coupon at purchase only.
No returns accepted.
Offer expires Sat., May 31, 1988.

White
**Zippered
Pillow
Protectors**
Polyester-Cotton-Washable
Protect your pillows.

drapery boutique

drapery boutique COUPON

**Zippered Pillow
Protectors**

Compare

Standard	\$3.99	\$1.88
Queen	4.49	2.88
King	4.99	2.88

Present coupon at purchase only.
Offer expires Sat., May 31, 1988.

Caddy Corner

White or Almond
Excellent Space Saver

Compare
at
\$13.99

drapery boutique

drapery boutique COUPON

Caddy Corner
Regular \$13.99

\$6.88
ea.

LIMIT 4

Present coupon at purchase only.
Offer expires Sat., May 31, 1988.

**6 Plastic
Hangers**
LIMIT 12 Decorator Colors

drapery boutique

drapery boutique COUPON

6 Plastic Hangers
Decorator Colors

78¢
FOR 6 HANGERS

LIMIT 12

Present coupon at purchase only.
Offer expires Sat., May 31, 1988.

**Colored
Shower Curtain
Magnetic Liners**

Compare **\$6.99**
at

LIMIT 3

drapery boutique

drapery boutique COUPON

**Shower Curtain
Magnetic Liners**

\$2.88
ea.

LIMIT 3

Present coupon at purchase only.
Offer expires Sat., May 31, 1988.

White-Ivory
**SHOWER
CADDY**

- Unique Honeycomb water drains
- Spacious
- Utility hooks
- Durable
- Installs instantly

Compare at \$9.00

drapery boutique

drapery boutique COUPON

SHOWER CADDY
White or Ivory

\$6.88
EA.

LIMIT 2

Present coupon at purchase only.
Offer expires Sat., May 31, 1988.

Wallpaper
— In Stock —

Mix or Match any
Number of rolls in
any combination
of patterns with
savings to 60%
on our everyday low price

drapery boutique

drapery boutique COUPON

**Wallpaper In Stock
Rebate**

Total Purchase	Instant Rebate
up to \$100.00	5%
up to \$150.00	10%
up to \$250.00	15%
up to \$300.00	20%

Present coupon at purchase only.
Offer expires Sat., May 31, 1988.

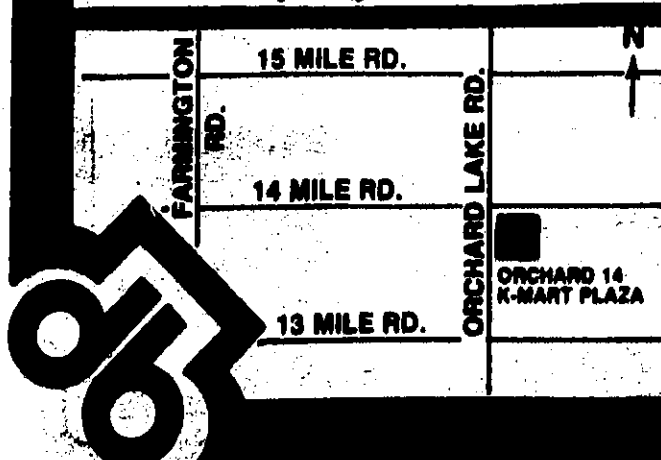

ORCHARD & 14 MILE CENTER

30858 Orchard Lake Road
Farmington
(313) 626-4313
Daily 9:30-6:00
Mon. & Thurs. 9:30-6:00
Open Sun. 12:00-4:00

GRAND RIVER & HAGGERTY Pepper Square

39253 Grand River
Farmington Hills, Pepper Square
(313) 478-3133
Daily 9:30-6:00
Open Sun. 12:00-4:00

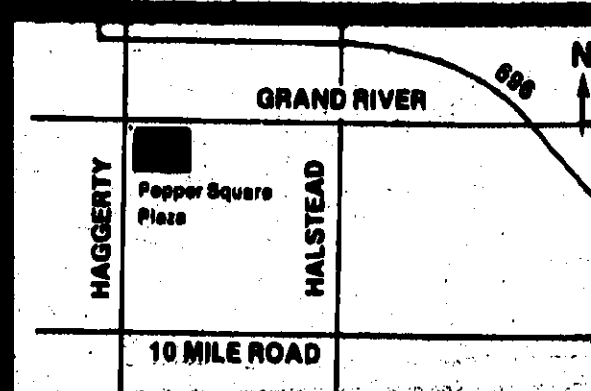

drapery boutique