

Hoad & Sons
Book Bindery
Springport, MI 49284

35¢
WEDNESDAY
November 5, 1986
Volume 31
Number 28
Three Sections
Plus Supplements

the NOVI NEWS

also serving Wixom and Walled Lake

Living POLICE AND THEIR GUNS: TOOLS OF THE TRADE/1C

Sports WILDCAT GRIDDEES JUST MISS PLAYOFFS/4C

Opinions TIME IS NEEDED TO STUDY SUPER SEWER/12A

City postpones action on rezoning issue

By PHILIP JEROME
managing editor

The controversy surrounding plans to develop an industrial subdivision immediately west of the Meadowbrook Lake subdivision will continue awhile longer.

The Novi City Council voted 5-2 Monday (Nov. 3) to table consideration of a request to rezone the 49-acre parcel from its current I-1 (light industrial) classification to an R-4 (single-family residential) designation.

Purpose of the delay? To give a special subcommittee composed of Meadowbrook Lake residents, the property owners and city officials an opportunity to work out an amendment to the I-1 zoning district that would make the light industrial classification more acceptable to abutting property owners.

The tabling action was opposed by Council Members Nancy Covert and Arlen Schroeder.

Covert maintained that council's refusal to act on the rezoning re-

quest put the Meadowbrook Lake residents in a "Catch 22" situation.

"When we say we won't rezone it for residential use, we're putting these residents in the position of having to work out the best compromise possible for themselves," she charged. "I have a problem with that."

Schroeder opposed the motion to table action on the rezoning request on the grounds that he believed the proposed single-family classification should be approved.

"If I were living in one of those

houses over there (abutting the proposed industrial subdivision), I would look at this (proposed industrial subdivision) exactly as they're looking at it," he said. "If an industrial subdivision were proposed next to my neighborhood, my neighbors would be furious, too."

At issue is a proposal to develop a 25-lot industrial subdivision on a 49-acre parcel on the north side of Nine Mile. The parcel lies between the Meadowbrook Lake subdivision on the east and the C&O railroad tracks on the west.

Meadowbrook Lake residents are opposed to having industrial development immediately adjacent to their homes and have suggested that the property be rezoned to a residential classification, noting that a residential designation is proposed on the city's master plan for land use development.

Although the Novi Planning Commission had already recommended tentative preliminary plat approval for the industrial subdivision, the city council asked the commission to consider rezoning the property to

the residential classification due to the potentially adverse impact on a residential subdivision.

Both the planning commission and Planning Consultant Brandon Rogers have advised the council that the light industrial classification should be retained.

The council's decision to table consideration of the rezoning request came on the recommendation of Rogers who said he is working with a special subcommittee that

Continued on 8

Voters reject charter change

Novi voters have rejected a proposed charter amendment that would change the way in which the city's mayor is elected.

Specifically, voters turned down the proposal by a margin of 3,220 to 1,971.

As a result, the citizens of Novi will continue to elect someone to serve as mayor every other year. The next mayoral election is slated for November 1987.

The proposed charter amendment called for the city council to elect one of its own members to serve as mayor for a two-year term. Under terms of the proposal, the general public would elect seven city council members, who in turn would select one of their own members to serve a two-year term as mayor.

Results rolled in slowly during Tuesday's general election.

In fact, Novi City Clerk Geraldine Stipp reported that not one of the city's 10 precincts had reported results as late as 10 p.m. — approximately the same time that Republican William Lucas was conceding victory in the gubernatorial race to incumbent Democrat James Blanchard.

In other races, Novi voters:
□ Backed William Broomfield's bid for re-election to his 18th District seat in the U.S. Congress. Broomfield received 4,441 votes to 1,883 for Democratic challenger Gary Kohut.

□ Gave Republican Frank Brock a narrow 3,350 to 3,217 edge over Democratic incumbent Jack Faxon

in the race for the 15th District seat in the State Senate.

□ Endorsed Willis Bullard's bid for re-election to the 60th District seat in the State House of Representatives. Bullard received 4,128 votes while Democratic challenger Marshall Spinner received 2,000 votes.

□ Gave Republican incumbent John Calandro a vote of support in his bid to win re-election to the 24th District seat on the Oakland County Board of Commissioners. Calandro received 4,086 votes, while Democrat Leo Foley was named on 2,022 ballots.

The vote totals are unofficial and represent only the Novi portion of the overall districts.

Some 7,201 of Novi's 17,705 registered voters showed up at the polls — a voter turnout of approximately 41 percent.

In Novi, voter rejection of the proposed charter amendment culminates a process which began after the November 1985 mayoral race in which current Mayor Patricia Karevich unseated former Mayor Robert Schmid.

Proponents of the charter proposal argued that having the mayor elected by the city council would, in effect, put the city in the same position as school boards throughout the state.

The proposed charter amendment was strongly opposed by two former mayors of the city — Schmid, who served from 1981-85, and Robert Daley, who served from 1973-75.



Novi News/CHRIS BOYD

Doing his duty

Eugene Lynch wasn't the first Novi resident to show up at the polls Tuesday morning, but he was there bright and early to do his civic duty, nevertheless. A resident of Novi for the past 13 years,

Lynch said he has been voting regularly for the past 50 years. He cast his first vote in the 1936 presidential election, and he even remembers the name of the candidate he voted for — Alf Landon.

Tougher standards proposed to protect trees

By PHILIP JEROME
managing editor

When there's an "oops" at his appliance store, Ollie Fretter has an "oops" sale.

When a developer in Novi has an "oops" involving the restrictions of the city's Woodlands Protection Ordinance, City Council Member Edward Leininger believes there also should be an "oops" sale.

But instead of cutting prices, Leininger would like to double the fine for either intentional or unintentional removal of protected trees.

"We've had an incident in the city

just recently where some trees were removed 'by accident,'" said Leininger, referring to property adjacent to the Meadowbrook Glens subdivision.

"It's too easy for the fellows driving these machines to get too close to these trees and nick them enough to effectively destroy them," he said.

"There's an 'oops' here and an 'oops' there, and pretty soon you have a lot fewer trees than you thought you were getting. In case of an 'oops,' we should have some sort of double indemnity clause in the ordinance," maintained the council member.

Leininger made his comments during a review of proposed amendments to the Woodlands Protection at the Nov. 3 city council meeting.

Although the council did not add an "oops" clause as recommended by Leininger, it did grant consensus approval for the proposed amendments to be set for public hearing in order to add them to the ordinance.

Ernest Aruffo, chairman of the Woodlands Implementation Committee, told council that the committee has held 15 sessions to attempt to eliminate the loopholes in the existing Woodlands Ordinance. "Our committee has looked at a lot of hypothetical situations and

we've also take a lot of field trips to review actual conditions," said Aruffo. "I think we've finally got it (Woodlands Ordinance) in the condition you wanted it to be in when it was first adopted."

Aruffo also noted that the committee has received considerable citizen input. "It's remarkable the interest people have in preserving our woods... particularly when they hear the wood cutter at work next to their property," observed Aruffo.

The committee has proposed a total of 10 amendments to the Woodlands Ordinance. Those proposed amendments include:

□ Historic/Specimen Trees: The amendment provides procedures and criteria for designating historic and specimen trees.

□ No Tree Affidavit: The ordinance has been amended slightly to change the phrase "no tree verification" to "no tree affidavit."

□ Forest Management Use Permits: The proposal has been added to require a Forest Management Use Permit for professional forestry work.

□ Emergency Actions: The amendment provides an exception for emergency actions to protect public health or safety, or to prevent damage to property. Replace-

ment trees may be required when the tree damages exceed that necessitated by the emergency situation.

□ Use Permit Applications: Proposed are a number of changes relative to the information that must be provided with a use permit application site plan. One section has been revised to clarify the manner of noting tree locations on the site plan. Another section has been revised to indicate that permanent protection of remaining trees may be required. Another section requires that utilities be depicted on

Continued on 9

Vigil at memorial

A 24-hour vigil is planned Saturday, Nov. 8, at the POW/MIA memorial in Oakland Hills Memorial Gardens at Twelve Mile and Novi Road.

Sponsored by Chapter 154 of the Vietnam Veterans of America, the event will include the posting of colors, a wreath presentation, a candlelight ceremony, the changing of the guard every hour and the reading of the 75 names contained on the "Michigan Remembers" memorial plaque.

The vigil will begin at this Saturday, Nov. 8, at 5 p.m. and conclude Sunday, Nov. 9, at 5 p.m. with a 21-gun salute and a closing ceremony.

For information about the vigil, call Bob Deckers of the Vietnam Veterans of America at 1-774-7000 or 399-0243.

In addition to this weekend's vigil in Novi, area residents will have an opportunity to view a replica of the Vietnam War memorial, half the size of the monument in Washington, D.C.

The replica will be available for public viewing for six days beginning Veteran's Day, Nov. 11, at the coliseum at the Michigan State Fairgrounds at Eight Mile and Woodward Avenue.

The memorial contains more than 58,000 names of men and women who died, or are missing in action, in the Vietnam War.

The memorial will be on view from 2-9 p.m. Tuesday-Friday, Nov. 11-14, noon to 9 p.m. Saturday, Nov. 15, and noon to 5 p.m. Sunday, Nov. 16.

No admission will be charged.

New & Used
Cars — Vans — Trucks

Over
425



Advertised in the
GREEN SHEET

348-3024

inside

BUSINESS CLASSIFIEDS 1B
EDITORIALS 1C
LIVING 1C
MICHELE FECHT 13A
NEARBY 6A
NOVI BRIEFS 4A
NOVI HIGHLIGHTS 2C
PHIL JEROME 12A
POLICE BLOTTER 4A
REC BRIEFS 5C
SPORTS 4C

EDITORIAL 349-1700
ADVERTISING 349-1700
CLASSIFIEDS 349-3024
DELIVERY 349-3627

Suspects nabbed on B&E charges

Two suspects in a breaking-and-entering case managed to elude a police barricade and then raced away from pursuing officers in a high-speed chase through rural Washtenaw County only to be arrested later that same day in Detroit's sixth precinct.

Facing charges are Timothy Tatum, 18, of Novi and Paul Puckett, 17, of Walled Lake. Both men were arraigned before a magistrate in Washtenaw County on charges of "breaking and entering of an occupied building with intent to commit larceny therein". Bail was set at \$2,000 cash or surety bond with 10 percent permitted.

Tatum posted bond and was released Wednesday, Oct. 29, while Puckett posted bond and was released Thursday, Oct. 30.

Pretrial examinations have been scheduled for both suspects. Police Chief Lee BeGole called the apprehension of the two suspects an outstanding example of police work.

The case began at approximately 10:15 a.m. on Monday, Oct. 27, when Novi Police Detective Ralph Fluhart received a telephone call from a friend who lives in Lyon Township.

Continued on 9

City Council tables industrial subdivision plans

Continued from Page 1
includes representatives of both the proposed developers and homeowners to develop an amendment to the I-1 zoning ordinance.

"Our joint committee has been working on this for some time and it's our feeling that the I-1 district can be adopted to make it more acceptable," said Rogers.
"With one or two more working sessions, I believe we can amend the I-1 district to make it acceptable to both Meadowbrook Lake and the developers."

ments to the ordinance will provide for three tiers of uses in the industrial district. He said one tier of uses (research facilities, for example) would be permitted anywhere within the I-1 district. A second tier (warehousing and assembly halls) would be prohibited immediately adjacent to abutting residential. And a third tier (manufacturing operations) would be permitted even further away from abutting residential.

"We have agreements on a lot of issues, but there's still some disagreement on which uses are permitted in each tier," said Rogers. "Mr. Bowman thinks I've put too many uses in the 'no-no' district."

Areas of agreement include a reduction of maximum building heights from 40 to 25 feet and a prohibition on loading docks on exterior rear walls that face residential districts.

Although Covert and Schroeder favored the request to rezone the property to a residential classification, the rest of the council members indicated that they believed the property should retain its light industrial classification.

Mayor Patricia Karevich noted that approval of the rezoning would resolve the concerns of the Meadowbrook Lake residents, but would merely shift the problem of residential abutting industrial uses to the west.

"If we did rezone it, the people who would live in these new houses would be living next to the industrial uses which already exist on the west side of the railroad tracks," she said. "We'd merely be shifting the problem."

"If we are able to amend the I-1 zoning classification to make it more compatible with abutting residential uses, we'll be taking steps to address this problem which exists in 32 additional locations throughout the community," she added.

Council Member Ronald Watson expressed similar sentiments. "The direction to repair the I-1 district so that it can co-exist adjacent to residential is the proper way to go," he said. "I think it's possible to find residential-friendly uses in an I-1 district that will be compatible with abutting residential subdivisions."

The ultimate motion to table consideration of the zoning request to work on an amendment to the I-1 zoning classification was criticized by Covert who called it "a step backwards."

Covert's criticism prompted a strong rebuttal from Council Member Hugh Crawford. "It's certainly not a step backwards to permit a committee of citizens, developers and city officials to continue work toward a positive conclusion to their mutual concerns," he said.

30% OFF all CARTER'S and OSHKOSH

20% OFF all HEALTH-TEX every day

Make Crowley's your first and only stop for famous-name children's clothing at big savings every day. We know the value of a dollar. That's why our buyers scour the market to bring you the newest in quality children's clothing at prices that are some of the lowest you'll find anywhere, day in and day out. For selection, savings and a policy that guarantees satisfaction... head for the Children's Depts. at all Crowley's stores.

EXAMPLE

OSHKOSH OVERALL \$25

LESS 30% 7.50

YOU PAY ONLY 17.50

AT CROWLEY'S

Shop tonight till 9 p.m. at Westborn, Macomb, Livonia, Lakeside, Farmington, Universal, Tel-Twelve, Wildwood Plaza and Flint. Grand River open till 7 p.m., New Center One till 6 p.m., Birmingham till 5:30 p.m.

YOU RANG?

NEED HELP?
Over Extended Exec? Harried Housewife? Limited Mobility? Call YOU RANG Personal Shopping Service. We Will Lighten Your Load. Call Glenna Long Northville 349-7344

Floor Covering

- Tile
- Carpeting
- Formica

100's of samples
145 E. Cady - Northville 349-4480

Hundreds of **MUSIC BOXES**

SPECIAL PRICE

11165 Europa Rd., Southgate 283-8790

FAMILY HEALTH

Ask The Doctor

Dr. George Pappas
Certified in Family Medicine

QUESTION: How is hypertension (high blood pressure) diagnosed and can it be treated without the use of medication?

ANSWER: Although high blood pressure is easy to diagnose it often goes undiagnosed for years unless found in a routine blood pressure reading or physical examination. Hypertension seldom gives warning signs or symptoms.

Blood pressure can be lowered in a number of ways. If your pressure is only slightly high, lifestyle changes may be enough to bring it within the normal range; you may not need any medication.

The following are some self-help tips in the prevention and treatment of hypertension.

1. Lose weight if necessary.
2. No smoking.
3. Decrease salt in your diet.
4. Decrease fat in your diet.
5. Restrict alcohol consumption.
6. Restrict caffeine.
7. Get regular exercise.
8. Get regular medical check-ups.

If your blood pressure is not adequately controlled after reasonable efforts with life style changes, there should be no hesitation in proceeding directly to drug therapy.

FAMILY HEALTH CARE CENTER, P.C.
420-4400

FAMILY MEDICINE
INTERNAL MEDICINE
OBSTETRICS & GYNECOLOGY
PEDIATRICS
RADIOLOGY
PSYCHOTHERAPY

40666 5 MILE, PLYMOUTH

Area Briefs

NEW HOME CONSTRUCTION is setting a record in West Bloomfield. The 979 residential permits issued in the first nine months of this year already exceed the 958 issued during all of 1985.

Township Building Director Russell Crites attributed the jump to construction of multiple housing units. Some 633 of the 979 permits issued were for multiple housing units.

AN INCREASE IN BURGLARIES is being reported in West Bloomfield Township for the first eight months of 1986. Crime reports show that burglaries are up 50 percent over the comparable period last year.

NO LEGAL OPPOSITION TO A TIFA DISTRICT for downtown Farmington will be initiated by the Farmington Public Schools. Although school officials did not offer a vote of confidence for establishment of the Downtown Development Authority (DDA), they voted a motion to initiate legal action against the City of Farmington's DDA on a 5-2 vote.

IMPROVED SECURITY FOR STUDENTS is needed in Southfield high schools to help prevent attacks on students which have surfaced again in recent weeks.

REPLACEMENT CREDITS: The amendment provides that landscaping trees shall not be considered for replacement credit purposes. In addition, replacement tree location is to be such as to best enhance, preserve and protect

Novi teen arrested after chase

Continued from Page 1

The man told Fluhart he had just received a call from his wife about a suspicious incident at their home.

"His wife told him that a young man had just come up to their door and asked directions to Johns Road," said Fluhart. "The woman was suspicious about the request, but managed to slammer out an answer and then watched the young man get back into the car with another individual."

"She came up with a very good description of the suspects and the vehicle they were driving, including the license plate number."

Fluhart said he has been investigating for quite some time a series of breaking-and-enterings which have a similar modus operandi in the north end of Novi and has developed a prime suspect and a good description of the suspect's car, including the license plate number.

"When the man mentioned the license plate number of the car that stopped by his house that morning, it set off an alarm in my head," said Fluhart. "I know my suspect's license plate number by heart, and the number of the car at the Lyon Township home was the same one

discovered the suspects had broken into the rear of the house and removed a large quantity of personal property from the interior."

"In light of the situation, we decided to attempt to make apprehension in our unmarked surveillance vehicles," said Fluhart.

As soon as the suspects left the residence, Fluhart radioed ahead to Officer Al Rasmussen who pulled his car across the road ahead of the suspects' vehicle to establish a roadblock.

"We were converging on the area from all directions, but the suspects spun around the roadblock, almost hitting Rasmussen in the process, and proceeded ahead at a high rate of speed," said Fluhart.

"The suspects were driving what appeared to be a high-powered Chevrolet Camaro, and all we had was our small-engine surveillance vehicles," Fluhart continued.

"It wasn't much of a contest. We managed to maintain sight of them for maybe two miles, but they were pulling steadily away from us and we lost sight of them on Napier Road and broke off the chase between 1 and 2 p.m."

Continued from Page 1

the plan. Another section deletes references to protective barriers.

REVIEW STANDARDS: Proposed

Report of Condition
Consolidating Domestic and Foreign Subsidiaries of the **Michigan National Bank - West Metro**

of Livonia in the state of Michigan, at the close of business on September 30, 1986 published in response to call made by Comptroller of the Currency, under title 12, United States Code, Section 161. Charter Number 15444 Comptroller of the Currency 7th District.

Statement of Resources and Liabilities		Thousands of Dollars
Cash and balances due from depository institutions	15,127	
Noninterest-bearing balances and currency and coin	NONE	
Interest-bearing balances	97,378	
Securities		
Federal funds sold and securities purchased under agreements to resell in domestic offices of the bank and of its Edge and Agreement subsidiaries, and in IBFs	21,000	
Loans and lease financing receivables:		
Loans and leases, net of unearned income	233,652	
LESS: Allowance for loan and lease losses	2,602	
LESS: Allocated transfer risk reserve	NONE	
Loans and leases, net of unearned income, allowance, and reserve	231,050	
Assets held in trading accounts	NONE	
Premises and fixed assets (including capitalized leases)	3,600	
Other real estate owned	601	
Investments in unconsolidated subsidiaries and associated companies	NONE	
Customers' liability to this bank on acceptances outstanding	NONE	
Intangible assets	NONE	
Other assets	3,419	
Total assets	372,175	
LIABILITIES		
Deposits:		
In domestic offices	333,584	
Noninterest-bearing	67,144	
Interest-bearing	266,440	
In foreign offices, Edge and Agreement subsidiaries, and IBFs	NONE	
Noninterest-bearing	NONE	
Interest-bearing	NONE	
Federal funds purchased and securities sold under agreements to repurchase in domestic offices of the bank and of its Edge and Agreement subsidiaries, and in IBFs	1,900	
Demand notes issued to the U.S. Treasury	5,132	
Other borrowed money	NONE	
Mortgage indebtedness and obligations under capitalized leases	1,690	
Bank's liability on acceptances executed and outstanding	NONE	
Notes and debentures subordinated to deposits	700	
Other liabilities	6,583	
Total liabilities	349,589	
Limited-life preferred stock	NONE	
EQUITY CAPITAL		
Perpetual preferred stock	NONE	
Common stock	2,830	
Surplus	2,830	
Undivided profits and capital reserves	16,826	
Cumulative foreign currency translation adjustments	NONE	
Total equity capital	22,586	
Total liabilities, limited-life preferred stock, and equity capital	372,175	

I, John M. Kilde, Accounting Manager of the above-named bank do hereby declare that this Report of Condition is true and correct to the best of my knowledge and belief.

John M. Kilde
Signature
October 30, 1986

We, the undersigned directors, attest to the correctness of this statement of resources and liabilities. We declare that it has been examined by us, and to the best of our knowledge and belief has been prepared in conformance with the instructions and is true and correct.

Lawrence L. Gladeburn
David L. Griffin
Bob D. Mills

FANS ARE FINE FOR WINTER, TOO!

CASABLANCA

DELTA II 4-BLADE / 3-SPEED VARIOUS BLADE STYLES. SEE COLORS BELOW.

IF YOU THINK OF FANS AS RELIEF FOR SUMMER HEAT, TRY THINKING OF THEM AS RELIEF FROM WINTER'S HEATING BILLS. CASABLANCA REVERSE CYCLE FANS BANISH "BIG BILLS BLUES".

HEAT RISES — AND IS WASTED NEAR THE CEILING. REVERSE CYCLE FANS FORCE HEATED AIR DOWNWARD TO YOUR LIVING AREA. THEY SAVE ENERGY AND KEEP YOU COMFY. TRYING IS BELIEVING. BEFORE THE FIRST OF WINTER'S CHILLING BLASTS, INSTALL CASABLANCA AND "PUT IT IN REVERSE".

SALE PRICES START AT (LIGHT KITS OPTIONAL) \$175⁰⁰

LADY DELTA 5-BLADE / 3-SPEED

ANTIQUE BRASS, BRIGHT BRASS, ANTIQUE WHITE, FERRARI RED, DESIGNER GREY, MAUVE, SNOW WHITE AND BRIGHT BRASS COMBINATION

SALE ENDS NOV. 15

Lighting Fixtures For Every Decor • Wiring Supplies And Light Bulbs

BROSE ELECTRICAL CONSTRUCTION, INC.

37400 W. 7 MILE ROAD LIVONIA, MI 48152 • (313) 464-2211

MON. - TUE. WED. SAT. 9:30-6:00 THURS. FRI. 9:30-6:00

Classic Interiors 7TH ANNUAL

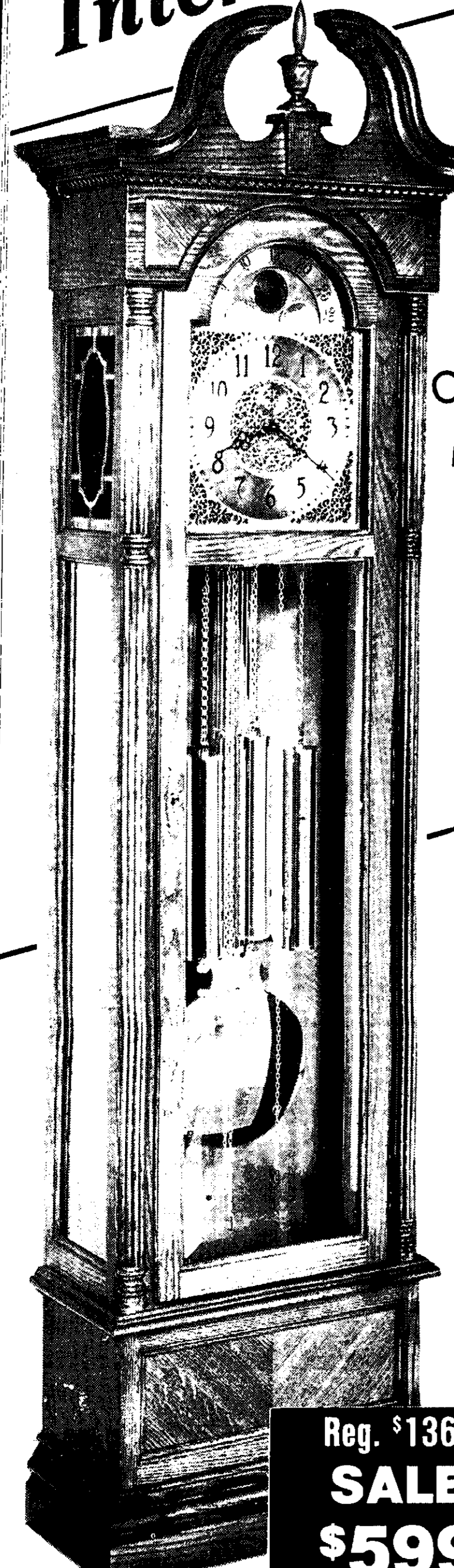

**TRUCKLOAD SALE
HOWARD MILLER CLOCKS
SAVE 30 TO 50%**

ONCE A YEAR — THIS IS THE ONLY FACTORY AUTHORIZED SALE OF HOWARD MILLER CLOCKS IN THE DETROIT METROPOLITAN AREA. A SPECIAL ARRANGEMENT WITH THE MANUFACTURER ENABLES US TO OFFER THESE CLOCKS AND MORE AT INCREDIBLE SAVINGS. SALE ENDS SAT., NOV. 8TH.

ASK ABOUT OUR HOLIDAY DELIVERY PLAN. OVER 100 MODELS OF GRANDFATHER, WALL, AND MANTEL CLOCKS TO CHOOSE FROM.



Reg. \$1360
SALE \$599
HT. 80 7/8"

Reg. \$1250
SALE \$799
HT. 79"

Reg. \$1895
SALE \$999
HT. 87 3/8"

Reg. \$1595
SALE \$999
HT. 78"

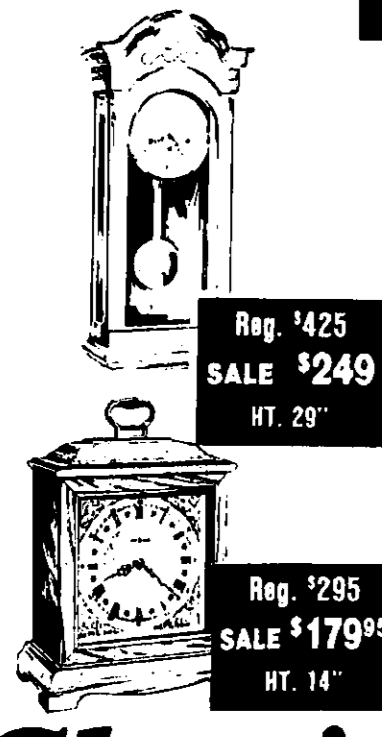

Reg. \$425
SALE \$249
HT. 29"



Reg. \$540
SALE \$399
HT. 33 1/2"



Reg. \$2,500
SALE \$1,499
HT. 85 1/2"



Reg. \$1,995
SALE \$1,299
HT. 80 1/2"

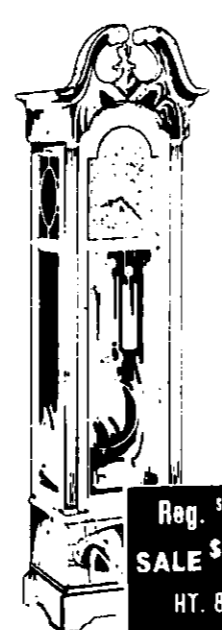

Reg. \$1,895
SALE \$1,099
HT. 83 1/2"



Reg. \$1,895
SALE \$999
HT. 83 1/2"

Classic Interiors



Member Interior Design Society Since 1937

20292 Middlebelt South of 8 Mile, Livonia, MI 474-6900

Mon., Thurs. & Fri. 9:30-9:00
Tues., Wed., Sat. 9:30-5:30

GREEN SHEET

Sliger/Livingston East

Want Ads INSIDE

Section B

Wednesday, November 5, 1986

Northville firm expands in new direction

Reef Mfg. breaks ground with calibration company

By NEIL GEOGHEGAN
Northville manufacturer, inventor and community benefactor Jan Reef died a year and a half ago, but the company he founded, Reef Manufacturing, continues to grow.
On Nov. 1, Reef's widow Nelly was on hand for the ribbon-cutting ceremony marking the grand opening of the Reef Calibration Service. The new service is a stab at diversifying the already successful and highly respected gauge manufacturing business.
Reef's daughter Marge Cinader, one of the major supporters behind the expansion along with plant manager Mike Bishop, said her father would have been very supportive of the new service and that's one of the reasons the company has pursued the idea.
"He would have just loved it," she said. "He was in the inventing end of the business and never even mentioned anything about calibration, but if he were here today, he'd be in glory over all this."
Jan Reef, a native of the Netherlands, launched the Northville business in 1941, and ever since the company has manufactured the Reef gauge. The gauge is designed to measure the accuracy of materials used and manufactured by numerous industries, including the automotive and aircraft industries.

"The new calibration service is separate from the gauges, but it's all related," Cinader reported. "We just wanted to diversify and add to the gauging."
According to Bishop, who is in charge of the new service, the calibration can measure the accuracy of materials to the millionth of an inch. It has much more sophisticated measurement capabilities than the gauges.
"We plan to do dimensional calibration," Bishop explained. "It's the same field as the gauges, but a different area."
Bishop was certified in the Navy as a calibration specialist, and it was through coaxing from him that the board of directors at Reef decided to take his suggestion and expand the business.
"I was a laboratory technician in the Navy and, when I got out, I tried to find a job in the calibration area but the jobs were few and far between. I knew we had space in the warehouse and so I began talking with Marge (Cinader) about the possibilities. Before I knew it, it has materialized."
Cinader pointed out that an area of the existing warehouse wasn't being used, so it has been converted into a laboratory to handle the new service. As a result, no addition to the existing and aircraft industries.

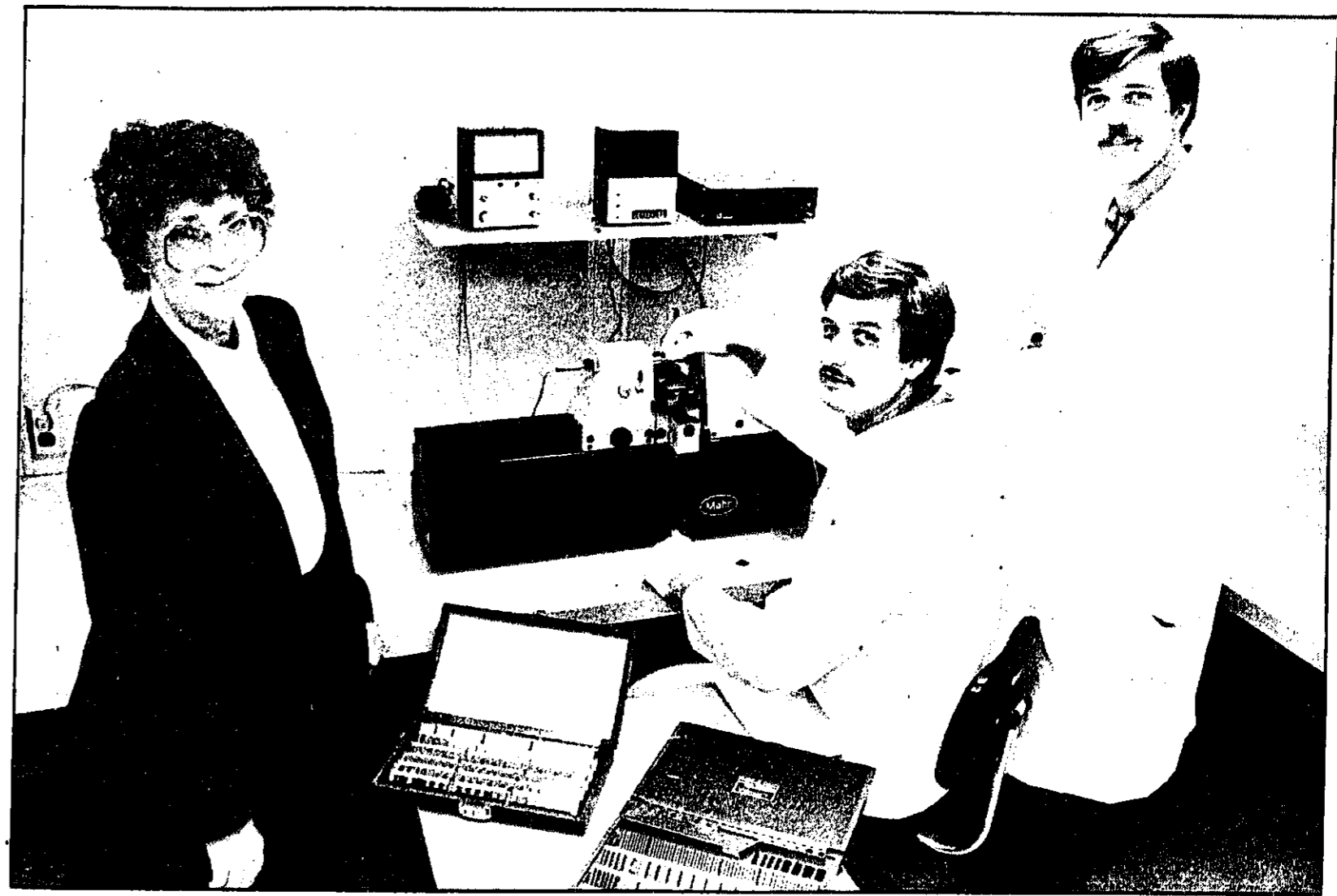

Reef Mfg. President Marge Cinader, Quality Controller Brian Pope and Plant Manager Mike Bishop demonstrate an electronic calibration machine at the company's headquarters in Northville. Photo by CHRIS BOYD

South Lyon Collision
Unibody Specialists
Professional Painting
Precision Bodywork
SPECIAL Rustproofing and Steam Cleaning
Cars & Small Trucks **\$95.00**
150 E. McHattie South Lyon
437-6100 or 437-3222

People Power
helps prevent birth defects
Support March of Dimes

Pelonis Portable Disc Furnaces
Heats 20' x 20' room for under \$1.00 a day • Money back guarantee
• Seasoned Firewood • Super K Kerosene
• Replacement Heater Wicks & Accessories
Fletcher & Rickard Landscape Supply Inc.
Open 7 Days Hours: Mon-Sat. 9-5 54001 Grand River
437-8009 Sun. 11-3 New Hudson

Sunflower Seed Black 100 lb. \$21.00	Wild Bird Mix 100 lb. \$14.40
---	--

• Sunflower • Wild Bird Mix • Finch Mix • Thistle • Hearts • Millet • Peanuts • Suet Cakes • Feeders
Wixom Co-Operative
49350 Pontiac Trail Wixom 624-2301

\$10.00 OFF ANY SERVICE CALL
AIR SUPPLY SYSTEMS
Heating & Air Conditioning
632-7757
Sales, Cleaning, Service
Custom Sheet Metal
Offer Good With Ad Thru '86 One Per Customer

CUSTOM DEER PROCESSING
THE Village Butcher Shop
(313) 684-6677 or (313) 685-0606

Family Foot Centers
FREE FOOT EXAM
MORN., AFTERNOON, EVE. & SAT. APPOINTMENTS AVAILABLE
887-5800
Highland Millford Foot Specialists P.C.
Dr. Lefkowitz, Dr. Steiner, Dr. Richard
• Ingrown Toenails • Diabetic Feet • Heel Pain • Arthritis Injury • Surgery - Office, Hospital
• Bunions • Fractures • Sprains • Anatomic Feet
• Warts - Hard/Foot • Child's Feet • Skin Growths • Sports Medicine • Orthotics
MOST INSURANCE ACCEPTED INCLUDING MEDICAID. BLUE CROSS, MEDICARE, AETNA, HANCOCK, AMERICAN COMMUNITY AND ALL OTHER PRIVATE CARRIERS. EXCLUDES X-RAY LAB TREATMENT

SEVERSON'S MILL & FARM SUPPLY
58675 Shelpo Rd., New Hudson, MI 48165
Live Stock (313) 437-1723 Mon.-Sat. 9-6
Hauling • Large Dealer • Complete Pet Supplies • Complete Line of Commercial Feeds
We carry lam's dog & cat food
Save, Buy in 500 lb. lot's

Lafayette Party Store
264 N. Lafayette, South Lyon 437-3666
"Under New Ownership"
Deli-Cold Kegs-Beer-Discount Wine Dept.-Party Trays-3 and 6ft. Subs-Pkg. Liquor

Sliced Bacon \$1.99 lb. Limit 6 lbs. with this coupon-expires 11-30-86	Coke Products 2 liters \$1.09 plus dep. Limit 4 with this coupon-expires 11-30-86	Party Trays Special \$2.59 person Choose 4 meats, 4 cheeses with this coupon expires 11-30-86
Eckrigh Bologna Reg., Garlic, Beef \$1.99 lb. Limit 3 lbs. with this coupon-expires 11-30-86	Gourmet Turkey Breast \$3.19 lb. Limit 6 lbs. with this coupon-expires 11-30-86	Corned Beef Round \$2.99 lb. Limit 4 lbs. with this coupon-expires 11-30-86
Gallo All Flavors \$5.79 3 liters No limit with this coupon-expires 11-30-86	Rheintanz Pilsporter Michelsberg 2/\$5.00 4 liters Limit 6 with this coupon-expires 11-30-86	Inglonook All Flavors \$5.79 3 liters No limit with this coupon-expires 11-30-86
J. Roget 750 ml. Champagne 2/\$4.50 All flavors Limit 6 with this coupon-expires 11-30-86	Carlo Rossi All Flavors \$5.79 4 liters No limit with this coupon-expires 11-30-86	Tosti Asti Spumanti \$5.99 Limit 4 with this coupon-expires 11-30-86
Paul Masson 3 liters \$5.99 All flavors No limit with this coupon-expires 11-30-86	Coors Reg. & Light \$4.99 12 pk. btls. plus dep. Limit 2 with this coupon-expires 11-30-86	Almaden 3 liters \$5.99 All flavors No limit with this coupon-expires 11-30-86

\$5.00 OFF With This Ad 125 Gals. Minimum Expires 11-12-86
39 Years Prompt, Dependable Service
No. 1 & No. 2 Fuel Oil
Diesel Fuel • Kerosene
Hydraulic Oils & Lubricants
24 Hour Burner Service Available
Call now for our "Low Cost" price quote
CHAIN OIL CO.
348-8733 933-6356
VOLUME DISCOUNTS 24 Hour Line



LOWELL RICHCREEK LAWRENCE BORRUSCH

LOWELL RICHCREEK of Northville has been named Vice President, Marketing, for the Reinforced Plastics Division of DiversiTech General, a subsidiary of GenCorp. He will be headquartered in the division's Southfield sales office...

LAWRENCE BORRUSCH of Northville has been promoted by Arbor Drugs to the newly-created position of Pharmacy Operations Supervisor. The promotion was announced by Arbor Drugs President Eugene Applebaum...

DR. KENNETH D. POSS, foot specialist, has announced the association of Dr. Randy H. Bernstein into his practice of podiatric medicine and surgery. Dr. Bernstein is a surgical staff member at Botsford General Hospital in Farmington Hills...



AMOS STACKHOUSE of Northville accepts Ford Parts and Service Division's 1986 Service Engineering Office Technical Award from General Manager Joe Kordick. Stackhouse, an engineer in the Advanced Service Engineering Department at Ford's Service Research Center in Dearborn...



CORR-PACK, INC. of Northville has been named by the Burroughs Corporation as one of its top Michigan suppliers for 1985. Gary Begin (center), president of Corr-Pack, is shown in the picture above accepting a Supplier Excellence Award in Burroughs world headquarters in Detroit...

THE NORTHVILLE KINDER-CARE Learning Center was the recipient of the Kinder-Care Learning Centers, Inc. "Best of Care Award 1986" for the district. The Northville center is located at 20675 Silver Springs Drive. "Best of Care" awards are presented at the district, regional and corporate levels to centers that have excelled in meeting requirements set forth by corporate offices...

WE SELL ONLY PREMIUM WINTERIZED FUELS. FISHER FUEL. ASK ABOUT VOLUME DISCOUNT 74¢. FUEL OIL No. 2. 150 Gallon Minimum. Exp. 11/12/86. SATURDAY DELIVERIES. MENTION COUPON WHEN ORDERING & RECEIVE 5 GALS. FREE!!!

HILLTOP FORD WINTER IS COMING! SNOW PLOW HEADQUARTERS. The "Big Red" by WESTERN. FULL POWER FEATURES. 50 in Stock-Ready for Delivery-More Coming. HILLTOP FORD & MERCURY INC.

Support March of Dimes BIRTH DEFECTS FOUNDATION.

INVENTORY CLEARANCE SALE. On All New & Used Lawn & Garden Equipment In Stock. JOHN DEERE logo.

SNOW THROWERS. Regular \$450 Save \$65. Sale \$385. NEW JOHN DEERE 520 SNOW BLOWER. Regular \$664 Save \$114. Sale \$550.

LAWN SWEEPERS. Attach a 36 inch lawn sweeper to your lawn tractor or riding mower and save hours of raking. HOURS \$30. PORTABLE GENERATOR SPECIAL. 4000 W - Large Enough For Most Homes!! Regular \$1385 Save \$207. Sale \$1178.

OUR LOWEST PRICES THIS YEAR! 3 FINANCING PROGRAMS*: 1. 20% Down with No Interest until 4/1/87 and No Payments until 5/1/87. 2. First of America Financing with No Money Down and Lower Monthly Payments. 3. John Deere Credit Card with 90 Days Interest Free. Approved Credit And Terms.

Thesier's YOUR JOHN DEERE LAWN AND GARDEN HEADQUARTERS. Member of The John Deere's "Millionaire's Club Circle of Excellence". 28342 Pontiac Trail South Lyon (313) 437-2091 Livingston County Residents (313) 229-6348

Tips for investing in the stock market

Some people know when to make a move in the stock market by the position of the planets. Others depend on intuition.

- Money Management tips: 1. Buy what you know. 2. Don't hold on to losers. 3. Don't invest more than you can afford to lose. 4. Be sure to get some goals. 5. Be realistic.

Existing home sales still exceed 1985 levels

While slipping below the pace of a month earlier, area existing home sales in September continued well ahead of those in 1985, according to a report from MetroMLS.

Reef Mfg. expanding

Continued from 1. "We had the area so we figured, 'Why not use it,'" Clander said. Reef Manufacturing sent out a brochure to potential customers about the new calibration service in September and a company catalog went out in October.

Donald E. McNabb Company Carpet Remnants. over 200 Wool Berber Remnants Now 50% off. Used Auto Show Carpet \$1.00 to \$4.50 per sq. yd. Now 10% off. Capture Carpet Spot & Soil Remover.

Women entrepreneurs to get help from state

Women entrepreneurs will have better access to state services, government contracts and capital under changes in the Michigan Commerce Department, according to Director Doug Ross. Ross announced the expansion of the department's Office of Women Business Owners (OWBO) when he addressed the National Association of Women Business Owners in Southfield.

Snowmobile Service Center. Authorized Dealer. Service • Parts • Accessories. 17 Year Professional Experience. BAKER'S LAWN & LEISURE. 1155 S. Milford Rd. (313) 887-2410

SUPAFLU CHIMNEY LINING SYSTEMS. INSULATES AND REINFORCES MAXIMUM CHIMNEYS WITHOUT REBUILDING. Financing Available with Approved Credit. BAKER'S LAWN & LEISURE. (313) 887-2410

YAMAHA We make the difference. Toro Announces an Innovation That Will Change The Shape of Snow Throwing. TORO logo.

Wicked wheels. The curve. TORO logo. Haven't you done without a Toro long enough?

BAKER'S LAWN & LEISURE. 1155 Milford Rd., Highland (313) 887-2410. YAMAHA We make the difference. BAKER'S LAWN & LEISURE. 1155 Milford Rd. (313) 887-2410

Employee 'leasing' a new alternative for small businesses

Many small employers in Michigan, particularly in the southeast, have discovered an alternative to hiring a worker.

These business owners are turning to "employee leasing" to satisfy their human resources needs. Like most sound business practices, employee leasing is based on a simple concept—contract labor.

Michigan's employee leasing boom is the result of a seemingly endless barrage of non-productive, frequently governmentally-initiated regulations and paperwork. By contracting with an employee leasing company, small business owners shelter themselves from this barrage.

The way it works seems so simple it is hard to believe that nobody thought of it sooner. A small employer simply transfers his contract employees to the leasing company of his choice, then instantly leases them back. Now all the liabilities of being an employer rest with the leasing company.

"The concept of employee leasing is so simple that people have difficulty comprehending that it's legal," said Gregory Parker, president of Southfield's Amstaff, Inc. "Of course, it is legal, and many large

companies have used similar arrangements extensively over the past quarter century. As a matter of fact, the federal government is currently the largest leaser of workers in the country."

"Aside from the administrative problems that leasing can eliminate," Parker continued, "small companies also can access significantly better benefits for their workers. Since the leasing company purchases benefits on a much larger scale, the per capita cost is significantly reduced."

Parker said Amstaff, Inc., currently provides medical, dental, life, vision and \$3 prescription cards to its workers. In addition, everyone is eligible to participate in a 401-k salary reduction pension plan and direct deposit of pay. The company is exploring the use of a plan which allows employees to pay for child care, deductibles, additional life insurance, etc. with non-taxable wages, which saves a lot of money in April.

Jerry Matson of Matson Heating, Inc., a heating and cooling contractor with offices in Pontiac and Flint, uses employee leasing and says things

qualify for the chance to win one of three grand prizes. First prize is a weekend for two at Chuck Muer's River Crab Inn, including dinner on Saturday night and brunch on Sunday; second prize is a miniature Wurlitzer jukebox that plays 565 hits; and third prize is dinner for two at any Chuck Muer Charley's restaurant.

Charley's restaurants to celebrate the '50s

Northville Charley's and all other Charley's restaurants of C. A. Muer Corporation in the Metropolitan Detroit area are reviving the fun, licks and foos of the '50s in an "All-American Barbecue" promotion through Nov. 20.

Bobby socks, poodle skirts, hula-boops, luzzy dice, Mouseketeer ears, Pat's Domino, jukeboxes and penny candy are being featured.

The All-American Barbecue menu, available at lunch and dinner, offers combinations of barbecued shrimp, ribs, chicken, fish and steak entrees priced from \$6.95 for Rik's ribs tails (barbecued rib brisket served with fries) to \$12.95 for Be-Boppin' Char-grilled Tuna Kabob (yellow-fin tuna char-grilled on a skewer with red bell pepper and herb butter sauce served with Cajun style rice).

Northville Charley's adds that diners who order from the All-American Barbecue menu can participate in the All-American Trivia Quiz, which features questions regarding '50s music and television. Those who answer at least 10 of the 15 ques-

tions qualify for the chance to win one of three grand prizes. First prize is a weekend for two at Chuck Muer's River Crab Inn, including dinner on Saturday night and brunch on Sunday; second prize is a miniature Wurlitzer jukebox that plays 565 hits; and third prize is dinner for two at any Chuck Muer Charley's restaurant.

In addition to the Northville Charley's there also are Charley's restaurants in Bloomfield, Southfield, Fairlane in Dearborn, Van Dyke in Warren, Eastside in Harper Woods, Upton in Madison Heights, Livonia, Wayne and Short Hills, N.J.

Cool Cats in the trivia quiz will be able to answer such questions as "What was The Ed Sullivan Show previously called?" and "What was the clown's name on Howdy Doody?" while they finish their meals with "Peppermint Twist" (a peppermint ice cream sundae) or "Blueberry Hill" (blueberry pie with French vanilla ice cream).

Amstaff said the concept of employee leasing is flourishing in Michigan. The industry itself is still young. A leasing arrangement should be carefully researched with strong emphasis on a company's experience and understanding of the law. State and local rules and regulations can vary tremendously. In most cases, a locally-based company has greater flexibility and understanding of these situations, Parker maintained.

Parker said it's wise to be careful when explaining a leasing arrangement. He noted that Amstaff, Inc., is a member of the National Staff Leasing Association, which polices the association and the industry.

While leasing is used in a wide variety of businesses, it does not work for everyone. If you are a small business owner, though, it is probably worth your time to investigate this blossoming, new service industry.

Experts in Washington, D.C. are predicting as many as 10 million individuals may be employed under leaseback arrangements by 1990. At present, it is estimated that 400,000 to 425,000 workers are being leased.

Amstaff said the concept of employee leasing is flourishing in Michigan. The industry itself is still young. A leasing arrangement should be carefully researched with strong emphasis on a company's experience and understanding of the law. State and local rules and regulations can vary tremendously. In most cases, a locally-based company has greater flexibility and understanding of these situations, Parker maintained.

Parker said it's wise to be careful when explaining a leasing arrangement. He noted that Amstaff, Inc., is a member of the National Staff Leasing Association, which polices the association and the industry.

While leasing is used in a wide variety of businesses, it does not work for everyone. If you are a small business owner, though, it is probably worth your time to investigate this blossoming, new service industry.

Experts in Washington, D.C. are predicting as many as 10 million individuals may be employed under leaseback arrangements by 1990. At present, it is estimated that 400,000 to 425,000 workers are being leased.

Amstaff said the concept of employee leasing is flourishing in Michigan. The industry itself is still young. A leasing arrangement should be carefully researched with strong emphasis on a company's experience and understanding of the law. State and local rules and regulations can vary tremendously. In most cases, a locally-based company has greater flexibility and understanding of these situations, Parker maintained.

Parker said it's wise to be careful when explaining a leasing arrangement. He noted that Amstaff, Inc., is a member of the National Staff Leasing Association, which polices the association and the industry.

SAVE 40-65% Gigantic Firestone Warehouse Sale

Limited Time Only Firestone SUPREME 3 years/50,000 miles \$26.88

Table with columns: SIZE, DESCRIPTION, REG. SALE, SIZE, DESCRIPTION, REG. SALE. Lists various Firestone tire models and prices.

MONROE SHOCKS BY MONROE. HEAVY DUTY SHOCKS \$14.88. GAS-MAXIMUM SHOCKS \$18.88. GAS-MAXIMUM SHOCKS \$24.88.

MILFORD HOWELL. Spartan Tire 304 N. Main 684-5251. Budget Tire 222 W. Grand River 517-548-1230.

One local call places a want ad in over 125,465 homes through the following newspapers & Shopping Guides: Northville Record, Novi News, South Lyon Herald, Milford Times, Brighton Argus, Pinckney Post Shopping Guide, Hartland Herald Shopping Guide, Fowlerville Review Shopping Guide, Livingston County Press, Monday Green Sheet.

RATES WEDNESDAY GREEN SHEET PLUS 3 ACTION ADS 10 Words for \$5.74. Contract Rates Available.

CLASSIFIED DISPLAY. Want ads may be placed until 5:30 p.m. Friday for that week's edition. Report any error immediately.

absolutely FREE. 001 Absolutely Free. Beautiful female kitten. 002 Absolutely Free. Naughy fudge and matchmaker. 003 Absolutely Free. Housedresses: Get equity on your home.

001 Absolutely Free. 2 Guinea pigs, with cage included. 002 Absolutely Free. Living room chairs. 003 Absolutely Free. Precious kittens.

004 Absolutely Free. 2 Hondas motorcycles. 005 Absolutely Free. 45 months female Affectionate kittens.

006 Absolutely Free. 2-year-old male German Shepherd. 007 Absolutely Free. 2-year-old female German Shepherd.

008 Absolutely Free. 2-year-old male German Shepherd. 009 Absolutely Free. 2-year-old female German Shepherd.

Sliger/Livingston Publications GREEN SHEET EAST CLASSIFIED ACTION ADS

DEER PROCESSING AT OZIE'S. Custom cutting Hartland area. DISCOVER Discovery Toys. LOTTERY Calendar: Brother Rice High School. DEER PROCESSING AT OZIE'S.

DEER PROCESSING AT OZIE'S. Custom cutting Hartland area. DISCOVER Discovery Toys. LOTTERY Calendar: Brother Rice High School.

DEER PROCESSING AT OZIE'S. Custom cutting Hartland area. DISCOVER Discovery Toys. LOTTERY Calendar: Brother Rice High School.

DEER PROCESSING AT OZIE'S. Custom cutting Hartland area. DISCOVER Discovery Toys. LOTTERY Calendar: Brother Rice High School.

DEER PROCESSING AT OZIE'S. Custom cutting Hartland area. DISCOVER Discovery Toys. LOTTERY Calendar: Brother Rice High School.

DEER PROCESSING AT OZIE'S. Custom cutting Hartland area. DISCOVER Discovery Toys. LOTTERY Calendar: Brother Rice High School.

DEER PROCESSING AT OZIE'S. Custom cutting Hartland area. DISCOVER Discovery Toys. LOTTERY Calendar: Brother Rice High School.

LOT OWNERS! Complete Price \$49,990. HUNDREDS OF PLANS. YOURS OR OURS. BLACKBURN BUILDERS.

Century 21. 1ST OFFERING on this condo - Very nice lowhouse features 2 bedrooms with large walk-in closets.

Century 21. FABULOUS QUAD LEVEL features 4 bedrooms, 2 baths, family room with fireplace.

Century 21. OUTSTANDING ADULT COMMUNITY CO-OP - 2 bedroom ranch features 2 baths, large living room.

Century 21. WATER FRONT. Come to our island and make it yours. Surrounded by water.

Century 21. 3 BEDROOM, 1 1/2 BATH BRICK & ALUMINUM CRANK UP on a large plot.

Century 21. 4313 W. Seven Mile (Highland Lakes Shopping Center) Northville 349-1212.

Malik. Building a reputation for excellence. (313) 229-8010.

"MICHIGAN'S LARGEST REAL ESTATE COMPANY"

Deere Season is on!

Compact Diesel Utility Tractors 9 Mos. Interest FREE! Plus \$400.00 Off Any Implement. Buy a "100" series and receive a FREE front mount blade worth \$199.00. Buy a "200" series and receive a 46" mid mount mower worth \$799.00 FREE. Buy a "420 or 430 receive a FREE 60" mid mount mower worth \$1,299.00. Register To Win 550 Generator Or Chainsaw Drawing On Nov. 22nd at our Public Open House. Ingram Equipment Co. 7200 W. Grand River Brighton, MI 48116 Phone - (313) 227-6550. FREE Pick Up and Delivery on Tractor Service. Call Our Service Dept. For Details.

Compact Diesel Utility Tractors 9 Mos. Interest FREE! Plus \$400.00 Off Any Implement. Buy a "100" series and receive a FREE front mount blade worth \$199.00.

Compact Diesel Utility Tractors 9 Mos. Interest FREE! Plus \$400.00 Off Any Implement. Buy a "200" series and receive a 46" mid mount mower worth \$799.00 FREE.

Compact Diesel Utility Tractors 9 Mos. Interest FREE! Plus \$400.00 Off Any Implement. Buy a "420 or 430 receive a FREE 60" mid mount mower worth \$1,299.00.

Free Pair of Leather gloves & 6 pack of oil with any chainsaw. Free wide angle wedge and leather gloves with a 52 logsplitter.

Buy a 420 or 430 receive a FREE 60" mid mount mower worth \$1,299.00.

FREE 46" mid mount mower with a 316 tractor FREE 50" mid mount mower with a 318 or 332.

Buy any generator and receive a FREE 2 1/2 gal. gas can full of gas.

Register To Win 550 Generator Or Chainsaw Drawing On Nov. 22nd at our Public Open House. Ingram Equipment Co. 7200 W. Grand River Brighton, MI 48116 Phone - (313) 227-6550. FREE Pick Up and Delivery on Tractor Service. Call Our Service Dept. For Details.

FREE pair of Leather gloves and FREE electric start with any self propelled snow thrower! STORE HOURS: M-F 8:00 a.m.-5:30 p.m., Thurs. 8:00 a.m.-7:00 p.m., Sat. 9:30 a.m.-3:30 p.m., Closed Sundays.

James C. Cutler Realty 103-105 Rayson, Northville 349-4030. LYON - First time reduced - \$129,900. Extensive deck and porch overlooking rear property.

HAVE YOUR KIDS GONE BACK TO SCHOOL? Now it's your turn. Consider career training for yourself! Data & Word Processing. CALL PONAC BUSINESS INSTITUTE FARMINGTON NOW 476-3145.

Real Estate One INC. Call for FREE "How to Buy a Home" Brochure. NORTHVILLE • NOVI 348-6430. Great starter or retirement Condo in popular Now complex.

NICHOLS REALTY INC. 41074 W. Seven Mile Rd., Northville. 348-3044

REAL ESTATE FOR SALE

016 Found

021 Houses

021 Houses

021 Houses

021 Houses

021 Houses

024 Condominiums For Sale

025 Mobile Homes For Sale

031 Vacant Property For Sale

061 Houses For Rent

064 Apartments For Rent

074 Living Quarters To Share

080 Office Space

101 Antiques

102 Antiques

A Few Prime Lots Still Available! In the Beautiful Woodlake Village Subdivision

ARBOR DEVELOPMENT CO. Offering many different plans & front yards to choose from with 1, 2 or 2 1/2 baths and 2.30 acre lots.

021 Houses

021 Houses

021 Houses

021 Houses

021 Houses

024 Condominiums For Sale

025 Mobile Homes For Sale

031 Vacant Property For Sale

061 Houses For Rent

064 Apartments For Rent

074 Living Quarters To Share

080 Office Space

101 Antiques

102 Antiques

J.R. Hayner REAL ESTATE 227-5400

021 Houses

021 Houses

021 Houses

021 Houses

024 Condominiums For Sale

025 Mobile Homes For Sale

031 Vacant Property For Sale

061 Houses For Rent

064 Apartments For Rent

074 Living Quarters To Share

080 Office Space

101 Antiques

102 Antiques

021 Houses

021 Houses

021 Houses

021 Houses

024 Condominiums For Sale

025 Mobile Homes For Sale

031 Vacant Property For Sale

061 Houses For Rent

064 Apartments For Rent

074 Living Quarters To Share

080 Office Space

101 Antiques

102 Antiques

021 Houses

021 Houses

021 Houses

021 Houses

024 Condominiums For Sale

025 Mobile Homes For Sale

031 Vacant Property For Sale

061 Houses For Rent

064 Apartments For Rent

074 Living Quarters To Share

080 Office Space

101 Antiques

102 Antiques

021 Houses

021 Houses

021 Houses

021 Houses

024 Condominiums For Sale

025 Mobile Homes For Sale

031 Vacant Property For Sale

061 Houses For Rent

064 Apartments For Rent

074 Living Quarters To Share

080 Office Space

101 Antiques

102 Antiques

REFINANCE NOW

021 Houses

021 Houses

021 Houses

024 Condominiums For Sale

025 Mobile Homes For Sale

031 Vacant Property For Sale

061 Houses For Rent

064 Apartments For Rent

074 Living Quarters To Share

080 Office Space

101 Antiques

102 Antiques

021 Houses

021 Houses

021 Houses

021 Houses

024 Condominiums For Sale

025 Mobile Homes For Sale

031 Vacant Property For Sale

061 Houses For Rent

064 Apartments For Rent

074 Living Quarters To Share

080 Office Space

101 Antiques

102 Antiques

COUNTRY FOLK ART SHOW & SALE

Antique Furniture

AMCON FOOD AUCTION

ANN ARBOR ANTIQUES MARKET

HOUSEHOLD

101 Antiques

ESTATE AUCTION

NOVING REAL ESTATE, INC. 201 S. Lafayette

Carol Mason Realty

DO NOT RENT FOR BOY!

Century 21

Century 21

Century 21

DO NOT RENT FOR BOY!

Century 21

Century 21

Century 21

DO NOT RENT FOR BOY!

Century 21

Century 21

Century 21

DO NOT RENT FOR BOY!

Century 21

Century 21

Century 21

DO NOT RENT FOR BOY!

Century 21

Century 21

Century 21

AT GLOBAL'S NEW LOCATION IN NORTHFIELD ESTATES

NEW OWNERS NEW MANAGEMENT PINE HILL APTS.

ESTATE AUCTION Saturday, November 8, 1986 - 10:30 a.m.

REACH OVER 165,000 POTENTIAL CUSTOMERS EVERY WEDNESDAY AND 136,000 EVERY MONDAY
HOUSEHOLD SERVICE AND BUYERS DIRECTORY
DEADLINE IS FRIDAY AT 3:30 P.M.

102 Auctions
103 Garage & Rummage Sales
104 Household Goods
105 Firewood and Coal
107 Miscellaneous
108 Lawn & Garden Care and Equipment

ANGEL AQUARIUM
MAINTENANCE & SALES
RESTAURANTS & SALES
ESTIMATES
517-546-1798

ANGEL AQUARIUM
MAINTENANCE & SALES
RESTAURANTS & SALES
ESTIMATES
517-546-1798

ANGEL AQUARIUM
MAINTENANCE & SALES
RESTAURANTS & SALES
ESTIMATES
517-546-1798

ANGEL AQUARIUM
MAINTENANCE & SALES
RESTAURANTS & SALES
ESTIMATES
517-546-1798

ANGEL AQUARIUM
MAINTENANCE & SALES
RESTAURANTS & SALES
ESTIMATES
517-546-1798

ANGEL AQUARIUM
MAINTENANCE & SALES
RESTAURANTS & SALES
ESTIMATES
517-546-1798

ANGEL AQUARIUM
MAINTENANCE & SALES
RESTAURANTS & SALES
ESTIMATES
517-546-1798

ANGEL AQUARIUM
MAINTENANCE & SALES
RESTAURANTS & SALES
ESTIMATES
517-546-1798

ANGEL AQUARIUM
MAINTENANCE & SALES
RESTAURANTS & SALES
ESTIMATES
517-546-1798

ANGEL AQUARIUM
MAINTENANCE & SALES
RESTAURANTS & SALES
ESTIMATES
517-546-1798

ANGEL AQUARIUM
MAINTENANCE & SALES
RESTAURANTS & SALES
ESTIMATES
517-546-1798

ANGEL AQUARIUM
MAINTENANCE & SALES
RESTAURANTS & SALES
ESTIMATES
517-546-1798

ANGEL AQUARIUM
MAINTENANCE & SALES
RESTAURANTS & SALES
ESTIMATES
517-546-1798

ANGEL AQUARIUM
MAINTENANCE & SALES
RESTAURANTS & SALES
ESTIMATES
517-546-1798

ANGEL AQUARIUM
MAINTENANCE & SALES
RESTAURANTS & SALES
ESTIMATES
517-546-1798

ANGEL AQUARIUM
MAINTENANCE & SALES
RESTAURANTS & SALES
ESTIMATES
517-546-1798

ANGEL AQUARIUM
MAINTENANCE & SALES
RESTAURANTS & SALES
ESTIMATES
517-546-1798

ANGEL AQUARIUM
MAINTENANCE & SALES
RESTAURANTS & SALES
ESTIMATES
517-546-1798

ANGEL AQUARIUM
MAINTENANCE & SALES
RESTAURANTS & SALES
ESTIMATES
517-546-1798

ANGEL AQUARIUM
MAINTENANCE & SALES
RESTAURANTS & SALES
ESTIMATES
517-546-1798

ANGEL AQUARIUM
MAINTENANCE & SALES
RESTAURANTS & SALES
ESTIMATES
517-546-1798

ANGEL AQUARIUM
MAINTENANCE & SALES
RESTAURANTS & SALES
ESTIMATES
517-546-1798

ANGEL AQUARIUM
MAINTENANCE & SALES
RESTAURANTS & SALES
ESTIMATES
517-546-1798

ANGEL AQUARIUM
MAINTENANCE & SALES
RESTAURANTS & SALES
ESTIMATES
517-546-1798

ANGEL AQUARIUM
MAINTENANCE & SALES
RESTAURANTS & SALES
ESTIMATES
517-546-1798

ANGEL AQUARIUM
MAINTENANCE & SALES
RESTAURANTS & SALES
ESTIMATES
517-546-1798

ANGEL AQUARIUM
MAINTENANCE & SALES
RESTAURANTS & SALES
ESTIMATES
517-546-1798

ANGEL AQUARIUM
MAINTENANCE & SALES
RESTAURANTS & SALES
ESTIMATES
517-546-1798

ANGEL AQUARIUM
MAINTENANCE & SALES
RESTAURANTS & SALES
ESTIMATES
517-546-1798

ANGEL AQUARIUM
MAINTENANCE & SALES
RESTAURANTS & SALES
ESTIMATES
517-546-1798

ANGEL AQUARIUM
MAINTENANCE & SALES
RESTAURANTS & SALES
ESTIMATES
517-546-1798

ANGEL AQUARIUM
MAINTENANCE & SALES
RESTAURANTS & SALES
ESTIMATES
517-546-1798

ANGEL AQUARIUM
MAINTENANCE & SALES
RESTAURANTS & SALES
ESTIMATES
517-546-1798

ANGEL AQUARIUM
MAINTENANCE & SALES
RESTAURANTS & SALES
ESTIMATES
517-546-1798

ANGEL AQUARIUM
MAINTENANCE & SALES
RESTAURANTS & SALES
ESTIMATES
517-546-1798

ANGEL AQUARIUM
MAINTENANCE & SALES
RESTAURANTS & SALES
ESTIMATES
517-546-1798

ANGEL AQUARIUM
MAINTENANCE & SALES
RESTAURANTS & SALES
ESTIMATES
517-546-1798

ANGEL AQUARIUM
MAINTENANCE & SALES
RESTAURANTS & SALES
ESTIMATES
517-546-1798

ANGEL AQUARIUM
MAINTENANCE & SALES
RESTAURANTS & SALES
ESTIMATES
517-546-1798

ANGEL AQUARIUM
MAINTENANCE & SALES
RESTAURANTS & SALES
ESTIMATES
517-546-1798

102 Auctions
103 Garage & Rummage Sales
104 Household Goods
105 Firewood and Coal
107 Miscellaneous
108 Lawn & Garden Care and Equipment

102 Auctions
103 Garage & Rummage Sales
104 Household Goods
105 Firewood and Coal
107 Miscellaneous
108 Lawn & Garden Care and Equipment

102 Auctions
103 Garage & Rummage Sales
104 Household Goods
105 Firewood and Coal
107 Miscellaneous
108 Lawn & Garden Care and Equipment

165 Help Wanted
166 Help Wanted Sales
170 Situations Wanted
HOME HEALTH AID: Certified Home Health Aide, Call (313)231-8029.

175 Snowmobiles
175 Campers, Trailers & Equipment
CAMPER For shorted pickup. Packed inside with light. Very good condition. \$200 or best offer.

225 Autos Wanted
JUNK Vehicles towed free. Local only. Call used parts. A-1's, (517)546-2520.

230 Trucks
1978 Ford N ton Supercab. 4 speed, power brakes, power steering, undercoated. 1981 GMC Jimmy V-6.

233 4 Wheel Drive Vehicles
1986 GMC Jimmy V-6, F.I., automatic, air, power windows, 4 door, black vinyl interior, door locks.

WAITPERSONS
Taxes & tips, hours, food & drink. Part-time, full-time. Apply in person.

BOAT AUCTION
Saturday, November 8, 10 a.m. State Fairgrounds, Detroit. Huge Fall Savings! Due to their excellent new boat sales and huge overstock of high-quality used boats.

STEVENS' WANTS WRECKED and JUNK CARS
CASH PAID (313)887-1482
VALVE Grinding, 4 cylinder Engines, 4 cylinder, 2 1/2 inch, \$30.

GARY UNDERWOOD USED CARS
904 E. Grand River Howell, MI 48043 517-548-5190
OPEN MON. & THURS. 8:30-9:00 TUES.-WED.-FRI. 8:30-6:00; SAT. 9:00-3:00

AFFORDABLE USED CARS
1981 Pontiac Bonneville, 2 door, P.B., P.S., air, cruise, stereo, delog, land top, prem. W/W, sport mirrors.

USED CAR LOW PRICE ZONE
STOP
THIS WEEK'S SPECIAL
1975 Champion 25 Ft. Mini Home ONLY \$7995

167 Business Opportunities
HEALTH Food Store for sale in Milford. \$25,000 incl. inventory and all equipment.

175 Snowmobiles
1978 Yamaha V-Max. Low mileage. Excellent condition. Call (313)487-5189.

225 Autos Wanted
JUNK Vehicles towed free. Local only. Call used parts. A-1's, (517)546-2520.

230 Trucks
1978 Ford N ton Supercab. 4 speed, power brakes, power steering, undercoated. 1981 GMC Jimmy V-6.

AFFORDABLE USED CARS
1981 Pontiac Bonneville, 2 door, P.B., P.S., air, cruise, stereo, delog, land top, prem. W/W, sport mirrors.

'86 IZUZI \$5995
'83 NISSAN PICK-UP \$3995
'84 GMC CONVERSION VAN \$12,995
'85 DODGE VAN \$8995
'83 GMC 1/2 TON PICK-UP \$5995
'84 CHEVROLET S-10 BLAZERS \$8495
'84 DODGE CARAVAN \$7995
'83 GMC CONVERSION VAN \$9995
'84 CHEVROLET S-10 PICK-UP \$6995

BUILDING LICENSE SEMINAR
Building trades - homeowning - apartment owners - prepare for the November election. Seven years experience. Jim Klausmeyer, 887-3034.

WONDERLAND MARINE WEST 'It's The Best Time To Buy' Super Out-Of-Season Discounts
STARCRRAFT BOATS WINTER STORAGE
Inside & Outside Rates 5795 E. Grand River (313)546-5122

Knights Auto Supply
4500 GRAND RIVER (1 BLOCK WEST OF I-94) NOV, MICHI, GRAND BLVD. PHOENIX 348-1250
BATTERY & CHARGING SYSTEM SPECIALS
HEAVY DUTY JUMPER CABLES \$9.49
CHAMPION BATTERY CAR-TRUCK-IMPORTS

233 4 Wheel Drive Vehicles
1978 Ford N ton Supercab. 4 speed, power brakes, power steering, undercoated. 1981 GMC Jimmy V-6.

AFFORDABLE USED CARS
1981 Pontiac Bonneville, 2 door, P.B., P.S., air, cruise, stereo, delog, land top, prem. W/W, sport mirrors.

CARS Feature Car Of The Week
1985 Cadillac Sedan Deville \$14,995
'85 RIVIERA \$13,495
'84 DELTA '88' BROUGHAM \$7995
'84 HONDA CRX \$6995
'84 OLDS FIRENZA \$6495
'84 BONNEVILLE \$7595
'86 BUICK SKYLARK LTD. \$9995
'84 BUICK SKYLARKS \$5995
'85 BUICK CENTURY \$8995
'84 BUICK SKYHAWK \$6995
'85 RENAULT ENCORE '81' \$3995
'84 OLDS CIERRA WGN. \$7495
'82 SKYLARK \$4995
'84 PONTIAC 6000 \$7995
'84 T-1000 \$4295
'82 CHRYSLER LeBARON \$4995
'83 FORD LTD \$6295

170 Situations Wanted
All cleaning ladies. Generat or parties. Mrs. Ross, (313)87-1197.

215 Campers, Trailers & Equipment
10 1/2 Foot camper. Sleeps 4 self contained. \$2,800. (313)229-8662 after 5 p.m.

225 Autos Wanted
JUNK Vehicles towed free. Local only. Call used parts. A-1's, (517)546-2520.

230 Trucks
1978 Ford N ton Supercab. 4 speed, power brakes, power steering, undercoated. 1981 GMC Jimmy V-6.

AFFORDABLE USED CARS
1981 Pontiac Bonneville, 2 door, P.B., P.S., air, cruise, stereo, delog, land top, prem. W/W, sport mirrors.

1986 Lincoln Continental
1985 Cougar
1984 Olds Toro
1984 Lincoln
1985 Olds Custom Cruiser

SUPERIOR'S FALL SAVINGS
1000 Lb. Pay Load
1987 S-15
Now Only \$6935
SUPERIOR CADILLAC OLDS-GMC
8282 West Grand River, Brighton
SALE HOURS: 9-8 Monday & Thursday, 9-8 Tuesday, Wednesday, Friday Open Saturday 11-3

McIntyres
SUPERIOR CADILLAC OLDS-GMC
Now Only \$6935
4 cyl., 4 speed
Prices Good 'til 11-8-86
227-1100
Where The People Make The Difference

Drive A New Car For \$3.46 A Day!
Mr. Goodwrench
603 W. Grand River, Downtown Brighton 229-8800

81, 82, 83, 84 CHEVROLET Beauville VANS
Now Loaded Call Now!
FARMINGTON HILLS AUTO SALES
10 Mile-Chester-Lake Rd. 471-2880

1984 Ford Crown Victoria
1978 Corvette
1985 Mustang GT
1986 Tempo GL
1985 Mustang GT
1984 Mercury Grand Marquis
1985 Mercury Grand Marquis

HILL TOP FORD
MICHIGAN'S LARGEST FORD-LINCOLN MERCURY DEALER
7885 W. GRAND RIVER • BRIGHTON MI
227-1761
Hours: Mon & Thurs. 9-9
Tues., Wed & Fri 9-6
SAT. 10-6

WALDECKER
PONTIAC • BUICK
7885 W. GRAND RIVER • BRIGHTON MI
227-1761
Hours: Mon & Thurs. 9-9
Tues., Wed & Fri 9-6
SAT. 10-6

SUPERIOR'S No Gimmick Sale
Just the Best Cars at the Best Prices
9.7% available on 86 Custom Cruiser
1979 Mercury Marquis 302 engine, runs very good, fully powered, new exhaust system, four new tires, built in 1981, \$1,400 or best offer. (313)229-4933

14,995
1979 Mercury Cougar, automatic, burgundy, runs good, 120,000 miles, available options, factory extra \$4,500 more.

16,995
1986 Cadillac Coupe 4 cylinder, 5 speed, full power, air, cassette, sunroof, alloy wheels, 120,000 miles.

8,995
1979 Plymouth Horizon TC3 Call for details evenings or weekends. (313)887-6786

10,995
1980 Buick Century, Black, 4 door, 60,000 miles, Excellent running condition. No rust. Must see! \$2,800. (313)229-4933

14,995
1981 Buick Century Limited 4 door, automatic, excellent condition. (313)229-4933

15,495
1981 Buick Century Limited 4 door, automatic, excellent condition. (313)229-4933

15,495
1981 Buick Century Limited 4 door, automatic, excellent condition. (313)229-4933

15,495
1981 Buick Century Limited 4 door, automatic, excellent condition. (313)229-4933

240 Automobiles
1979 Mercury Marquis 302 engine, runs very good, fully powered, new exhaust system, four new tires, built in 1981, \$1,400 or best offer. (313)229-4933

240 Automobiles
1980 Olds Omega blue air conditioning, excellent condition. (313)229-4933

240 Automobiles
1980 Pontiac Sunbird 70,000 miles, runs good. \$1,200. (313)229-4933

240 Automobiles
1979 Mercury Marquis 302 engine, runs very good, fully powered, new exhaust system, four new tires, built in 1981, \$1,400 or best offer. (313)229-4933

240 Automobiles
1980 Buick Century Limited 4 door, automatic, excellent condition. (313)229-4933

240 Automobiles
1981 Buick Century Limited 4 door, automatic, excellent condition. (313)229-4933

240 Automobiles
1981 Buick Century Limited 4 door, automatic, excellent condition. (313)229-4933

240 Automobiles
1981 Buick Century Limited 4 door, automatic, excellent condition. (313)229-4933

241 Vehicles Under \$1000
1985 Escort Excellent condition, runs good, \$4,000 or best offer. (313)229-4933

1985 Escort 2 door, 4 speed, air, radio, delogger, excellent condition. Low mileage. (313)229-4933

1985 Ford Crown Victoria 4 door, fully loaded, 44,000 highway miles, \$8,000 or best offer. (313)229-4933

1985 Toyota LS Sharp! Loaded! 2 door, 5 year UNLIMITED MILEAGE WARRANTY. \$6,800 or offer. (313)229-4933

1985 Volvo 740 GLE 2 door, 5 speed, air, cruise, am/fm stereo cassette, \$6,000. (313)229-4933

1985 Nissan 300ZX Excellent condition. Loaded. 24,000 miles. (313)229-4933

1985 Buick Regal 4 door, 60,000 miles, excellent condition. (313)229-4933

1985 Chevrolet 2 door, loaded, priced to sell. \$4,200. (313)229-4933

1985 Olds Cutlass Supreme 4 door, air, stereo, wires, tilt, cruise, 66,000 highway miles, squeaky clean. \$6,200. (313)229-4933

1985 Olds Cutlass Supreme 4 door, air, stereo, wires, tilt, cruise, 66,000 highway miles, squeaky clean. \$6,200. (313)229-4933

1985 Olds Cutlass Supreme 4 door, air, stereo, wires, tilt, cruise, 66,000 highway miles, squeaky clean. \$6,200. (313)229-4933

GOBBLE UP THESE SAVINGS!

'85 S-10 Blazer 4x4, loaded \$10,995	'85 MT. CARLOS \$10,495	'85 ASTRO VAN 5 pass., auto., air \$9995
'85 CAPRICE WAGON \$8995	'85 PONT. 6000 SE \$8695	'84 S-10 P.U. Auto. \$5695
'85 PONT. 6000 SE \$8695	'84 BUICK REGAL \$7995	'84 CELEBRITY WAGON \$5995
'84 BUICK REGAL \$7995	'83 BUICK REGAL \$6995	'84 CITATION 4 DR. \$5695
'84 CELEBRITY WAGON \$5995	'84 CAMARO \$4995	'80 FIREBIRD \$2895
'84 CITATION 4 DR. \$5695	'80 FIREBIRD \$2895	'83 CHEVETTE \$2195
'82 Chev. Pickup 1/2 ton \$5295	'83 CHEVETTE \$2195	'82 Ford F-150 Pickup, auto. \$2995

Dick Morris
CHEVROLET
"Your Favorite Metro Chevrolet Dealer"
2199 Haggerty • Walled Lake
624-4500
MON. AND THURS. TIL 9 P.M.
TUES., WED., FRI. TIL 6 P.M.

The '87s are moving in and were moving them out.

Dodge
CARS TRUCKS

You can't afford to wait. Head for the Dodge Boys right now and check out the exciting line-up of new 1987 Dodge cars and trucks.

You'll see the new Dodge Shadow, a superbly equipped new breed of compact car. You'll see the new Dodge Dakota, the first true mid-sized pickup ever made. Plus, you'll see all the other great Dodge cars and trucks for 1987. They're in... but they're moving out - fast! Right now, at the Dodge Boys.

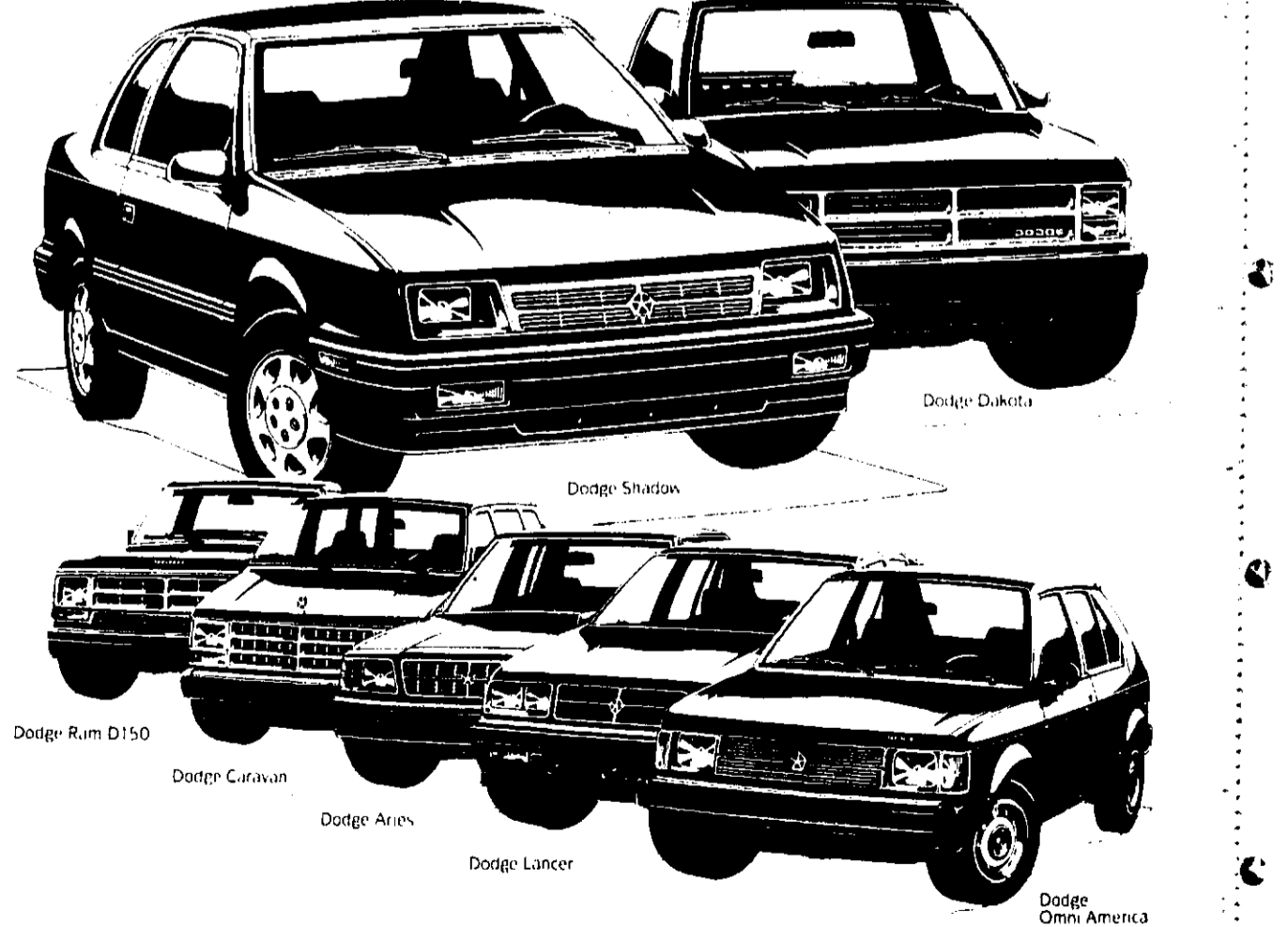

Buckle Up For Safety

JOHN COLONE
CHRYSLER, PLYMOUTH, DODGE, INC.
1295 E. M-36
Pinckney, Michigan
Telephone 878-3154, 878-6086

Dodge Boys
DIVISION OF CHRYSLER MOTORS
Setting new standards of performance.

You've got to be kidding sale!

Check Our Values

1979 Coupe DeVille \$2999	84 Topaz \$3999
'83 VW GTI \$4599	81 Chevy Van \$3999
85 Crown Vic Wagon \$9999	85 Crown Vic \$8999
83 Grand Prix \$4999	84 Gran Marquis-LS \$9999
1981 Pontiac T-1000 \$2499	1978 Chev. C-30 Stake \$4999
84 Escort Wagon \$3999	'84 Horizon \$2299
80 Cutlass Supreme \$2399	1985 F-250 Pick-Up \$9999
1982 Escort \$2499	'83 Crown Vic \$6999
85 Escort \$4999	'84 EXP \$4999
1986 Aerostar XL \$11,999	1983 F-250 Pick-Up \$6999

NEW "SIMPLIFIED" TAX LAWS TO COST CAR BUYERS THOUSANDS!

Come in to John Colone's TODAY! Cut Your Best Deal And Get The Best Tax Advantage NOW!

Over 20 1986 Cars & Trucks in Stock SAVE-SAVE-SAVE

"ONLY 1 LEFT!"
1986 W-150 4x4 Black, auto., V-6, snow plow available!
\$11,895

PLYMOUTH VOYAGER
Still nothing like it! **\$9987***

PLYMOUTH HORIZON AMERICA
One of the Best small car values from America or Japan **\$5787***

QUALITY PRE-OWNED SPECIALS - MUST HAVE AD FOR ADVERTISED PRICE!

1986 Dodge Ram Charger Loaded, 2 to choose "SAVE" \$3995	1985 Buick Skyhawk Air, auto., p.s., p.b., am/fm. \$5995	1985 Plymouth Reliant Wagon Air, auto., p.s., p.b., am/fm. \$8595	1984 Dodge Charger Super nice 2nd car. \$3995	1984 Dodge Omni Nice 2nd car, only 32,000 mi. \$3995	1983 Dodge "600" Air, auto., p.s., p.b., am/fm, cruise. \$4995
1986 Dodge Ram Air, p.s., p.b., am/fm. \$7295	1985 Chrysler 5th Avenue Loaded, Only 13,000 mi. \$8995	1984 Dodge Daytona 5 spd., p.s., p.b. \$5295	1984 Chrysler LeBaron Air, auto., p.s., p.b., cruise \$5495	1982 Buick Riviera Loaded, nice! \$7995	1982 Buick Station Wagon Loaded, nice! \$4995

JOHN COLONE
CHRYSLER, PLYMOUTH, DODGE, INC.
1295 E. M36 • Pinckney
878-3154 - 878-6086

SERVICE HOURS:
M-F 9 a.m. - 9 p.m.
Sat. 9 a.m. - 12 noon

BUSINESS HOURS:
M-F 8 a.m. - 8 p.m.
Sat. 9 a.m. - 3 p.m.

WARNING! Low Price Zone Ahead BRIGHTON BARGAINS

1987 PONTIAC 1000
\$9995
48 month lease, \$500 down payment - \$250 security deposit due at delivery. Total monthly payments, \$4,797.50.

1986 BUICK CENTURY
\$9995
48 month lease, \$500 down payment - \$250 security deposit due at delivery. Total monthly payments, \$4,797.50.

1987 PONTIAC GRAND AM
\$17495
48 month lease, \$500 down payment - \$250 security deposit due at delivery. Total monthly payments, \$4,797.50.

1987 BUICK LESABRE
\$23995
48 month lease, \$500 down payment - \$250 security deposit due at delivery. Total monthly payments, \$4,797.50.

SOME '86 MODELS STILL AVAILABLE AT EVEN GREATER SAVINGS!

WALDECKER
GRAND RIVER
1295 E. M-36
Pinckney, Michigan
Telephone 878-3154, 878-6086

THE NEW HOME OF WALDECKER PONTIAC-BUICK
7885 W. GRAND RIVER BRIGHTON MI 227-1761

ROOT FOR THE UNDERDOG.

Hurt, alone, unwanted. They are the victims of tragic accidents or intentional cruelty. Unfortunately, the Michigan Humane Society handles scores of these sad cases daily, receiving hundreds of calls reporting animals in distress. Our rescue vans are on the road thirteen hours a day, seven days a week. But our goal is around-the-clock vigilance. These rescue efforts and medical attention take money. More than we have. Won't you please help these underdogs? They deserve a fighting chance.

Give to the Michigan Humane Society.
7401 Chrysler Dr., Detroit, MI 48211

Detroit 872-3400
Westland 721-7300
Auburn Hts. 852-7420

MICHIGAN HUMANE SOCIETY

PHOTO: Courtesy of Massachusetts Society for Prevention of Cruelty to Animals.

240 Automobiles 241 Vehicles Under \$1000. WHAT IS THE BARGAIN BARREL? DON'T WAIT UNTIL MONDAY!

SPIKER LARGEST VOLUME FORD-MERCURY DEALERSHIP IN SOUTHEASTERN MICHIGAN FOR 19 CONTINUOUS YEARS

SUPER MARKET SAVINGS 200 1986 - 1987 FORD'S • MERCURY'S • FORD TRUCKS IMMEDIATE DELIVERY

SPECIAL SAVINGS 1986 DEMO'S Only 6 Left!!

BUY OR LEASE ORDER YOURS TODAY A, B X & Z PLANS WELCOME



SELLING FORDS AND MERCURYS SINCE 1950 BRING US YOUR BEST DEAL... WE'LL MAKE IT BETTER

SPIKER FORD MERCURY 130 S. Milford Road, Milford 684-1715 or 963-6587

1973 Pontiac Rusty runs good. 1976 Chevy Nova Mechanically sound. 1977 Mercury Marquis for parts.

UNCLE LOU IS HAVING A VERY SPECIAL ORDER SALE!

BRAND NEW '87 CHEVETTE 2 DOOR HATCHBACK \$4829* BRAND NEW SPECIAL FACTORY ORDERED '87's CHEVETTE 4 DOOR HATCHBACK \$5300

Lou LaRiche CHEVROLET Switch to LaRiche

HOME COMING Come Home Safe

1977 Chevy Monza 2 door. 1977 Dodge 5500 or best offer. 1977 Thunderbird \$750, very clean.

Get A WHALE OF A DEAL!

From FEIGLEY MOTOR SALES

Table listing car models and prices: 1979 Olds Toronado \$3495, 1979 Mustang \$2495, 1979 Buick LeSabre 2 Dr. \$2995, 1983 Chevrolet Celebrity \$4495, 1982 Escort L 2 Dr. \$2495, 1985 Chevrolet Impala 4 Dr. \$6995.

FEIGLEY MOTOR SALES BUICK OLDS 750 G.M. Rd., Milford, 684-3005

1978 Chevrolet 2 door, 4 speed. Excellent winter car. 1978 Ford LTD. Fairchild chauffeur \$600.

OUR SECRET OF SUCCESS AT BRIGHTON CHRYSLER PLYMOUTH • DODGE

LET US PROVE THAT NEW DODGES COST LESS IN BRIGHTON

NEW 1987 DODGE OMNI AMERICA AIR CONDITIONED, AUTOMATIC DISCOUNT PACKAGE FRONT WHEEL DRIVE \$7333

BRIGHTON CHRYSLER • PLYMOUTH • DODGE 9827 E. Grand River, Brighton 229-4100

240 Automobiles 240 Automobiles 240 Automobiles 240 Automobiles

DODGE TRUCK HEADQUARTERS TRY TRUCKIN!

THE ALL NEW '87 DAKOTA "AMERICA'S ONLY MID SIZE PICKUP" \$14901* NEW '87 RAM 50 \$11722*

NEW '87 W-150 4X4 \$26298* NEW '87 D150 \$16641* NEW '87 W250 SNOW PLOW \$5000 REBATE

PLUS! Duraliner Bed Liner**!! AT NO ADDITIONAL COST - MUST PRESENT AD AT TIME OF PURCHASE.

241 Vehicles Under \$1000. 1973 Pontiac Rusty runs good. 1976 Chevy Nova Mechanically sound.

WILSON FORD & MERCURY Dealer Incentive Means Extra Savings For You...

1987 Ranger XLT \$7599* 1986 F-150 Pick Up \$7895* 1987 Ranger "S" PICK-UP \$6395*

WILSON FORD & MERCURY 8704 W. Grand River • Brighton • 227-1171

241 Vehicles Under \$1000. 1977 Mercury Marquis for parts. 1977 Datsun 2802, 2 plus 2 5 in. g. brakes.

THE PRIDE IS BACK!

BRIGHTON CHRYSLER PROVES IT FOR 1987, THE PRIDE IS BACK, BORN IN AMERICA

Plymouth Sundance \$7799* Chrysler LeBaron GTS \$9,533*

BRIGHTON CHRYSLER PLYMOUTH DODGE 9827 E. Grand River 229-4100

Give a hoot. Don't pollute. Forest Service, U.S.D.A.

Don't Miss It! MONDAY GREEN SHEET

"Chocked Full" of Values from Your Favorite Retailers & Food Stores

Delivered to over 49,000 homes in Livingston County, South Lyon & Milford Areas

Reach This Growing Market With Your Classified Ad

To place your classified ad: Brighton, Pinckney or Hartland (313)227-4436

Classified Crafts PLANS AND PATTERNS

MODULAR DECKING. Very easy decking modules are much simpler than long-plank decking.

ARBOR TRELLIS. Yard trellis displays flowers and climbing greenery.

Classified Crafts Dept. C-48178 Box 1000 Bixby, OK 74008

1987 Ranger XLT 114 inch wheel base, XLT trim, fuel injection, 2.3 liter engine.

F-SERIES FORD TRUCKS with Manual Transmission \$500 Add Discount With Automatic Transmission \$300 Add Discount

1986 F-150 Pick Up 300 CID, 4 speed overdrive, cloth seats, tach, headlamps.

1987 Ranger "S" PICK-UP Twin I-Beam front end, 2.0 L engine, 5 speed manual transmission.

Look! Oct. 20 to Nov. 15th Buy a 1986 or 87 Ranger Pickup and Receive a FREE BED LINER \$300 Value

See It Today! 1987 RANGER "S" PICK-UP

1987 Ranger "S" PICK-UP \$6395* Plus shipping tax, title

WILSON FORD & MERCURY 8704 W. Grand River • Brighton • 227-1171

AND YOU GET CHRYSLER'S FAMOUS 5/50 PROTECTION PLAN. Protects powertrain and against outer body rust-through.

THE PRIDE IS BACK - THE EXCITEMENT'S NEW. SEE US TODAY.

BRIGHTON CHRYSLER PLYMOUTH DODGE 9827 E. Grand River 229-4100

One local call places your classified ad in over 49,000 homes every Monday throughout Livingston County and the South Lyon and Milford areas...

Map showing locations: Fowlerville, Hartland, Howell, Brighton, Pinckney, South Lyon, Milford.

Monday Green Sheet Delivered to over 49,000 homes in Livingston County and the South Lyon and Milford areas

Monday Green Sheet DECEMBER 2



A Class Act

When you're selling dancing lessons, renting tuxedos or just advertising a new top hat, you'll need to pick the right partner to help you get out on the town. That's where we step in. We're the advertising Publications, publishers of the Green Sheet and related ads.

Through the Green Sheet, we can give your ad a receptive audience. For just \$5.74 (non-commercial rate) we will place your 10-word classified ad in the Wednesday Green Sheet Plus Three. The Wednesday Green Sheet Plus Three is the classified section which appears in four of our six community newspapers. The "Plus Three" includes three shopping guides in Fowlerville, Hartland and Pinckney.

With just one local phone call, we can place your ad in the Wednesday Green Sheet Plus Three and your advertising message will play in over 65,000 households in Livingston County, Brighton, North Lyon, Milford, Northville and Novi.

If you're looking to saturate a specific area on Monday with your ad, we have three other shopping guides, all available to provide total market coverage. They are the Mon-

day Green Sheet, serving Livingston County, South Lyon and Milford; the Green Sheet Shopping Guide, serving Dexter and Chelsea; and the Highland Shopping Guide. Again, just one phone call will put your ad in the spotlight.

For your convenience, you can place your classified ad in the Green Sheet or our shopping guides through any one of these local phone numbers:

Brighton	(313) 227-4436
Dexter	(313) 428-5222
Fowlerville	(313) 548-2570
Hartland	(313) 227-4436
Livingston County	(313) 548-2570
Milford	(313) 665-8705
Northville	(313) 348-3022
Novi	(313) 348-3022
Pinckney	(313) 227-4437
South Lyon	(313) 437-4133

Don't wait for the last minute on this great advertising medium. Our phones get busier as the deadlines get nearer so it helps if you call early. The deadline for the Wednesday Green Sheet Plus Three is 3:30 p.m. Monday. The Monday Green Sheet deadline is noon Friday. The deadlines for the Green Sheet Shopping Guide (for Dexter and Chelsea) and the Highland Shopping Guide is noon Wednesday.

Don't get your toes stepped on. Call Sliger-Livingston. We're a real 'class act'.

Sliger/Livingston Publications, Inc.

the NOVI NEWS

Living

JOB SEARCH:
Novi Jaycees offer 'job search' workshop/2C

CHILD PSYCHOLOGY:
Co-op Nursery hosts expert on child discipline/2C

CHORALAIRES:
Tickets available for Choralaires concert/2C

CHRISTMAS VISIONS:
Meadowbrook Church schedules holiday bazaar/3C

1C
WEDNESDAY
November 5,
1986

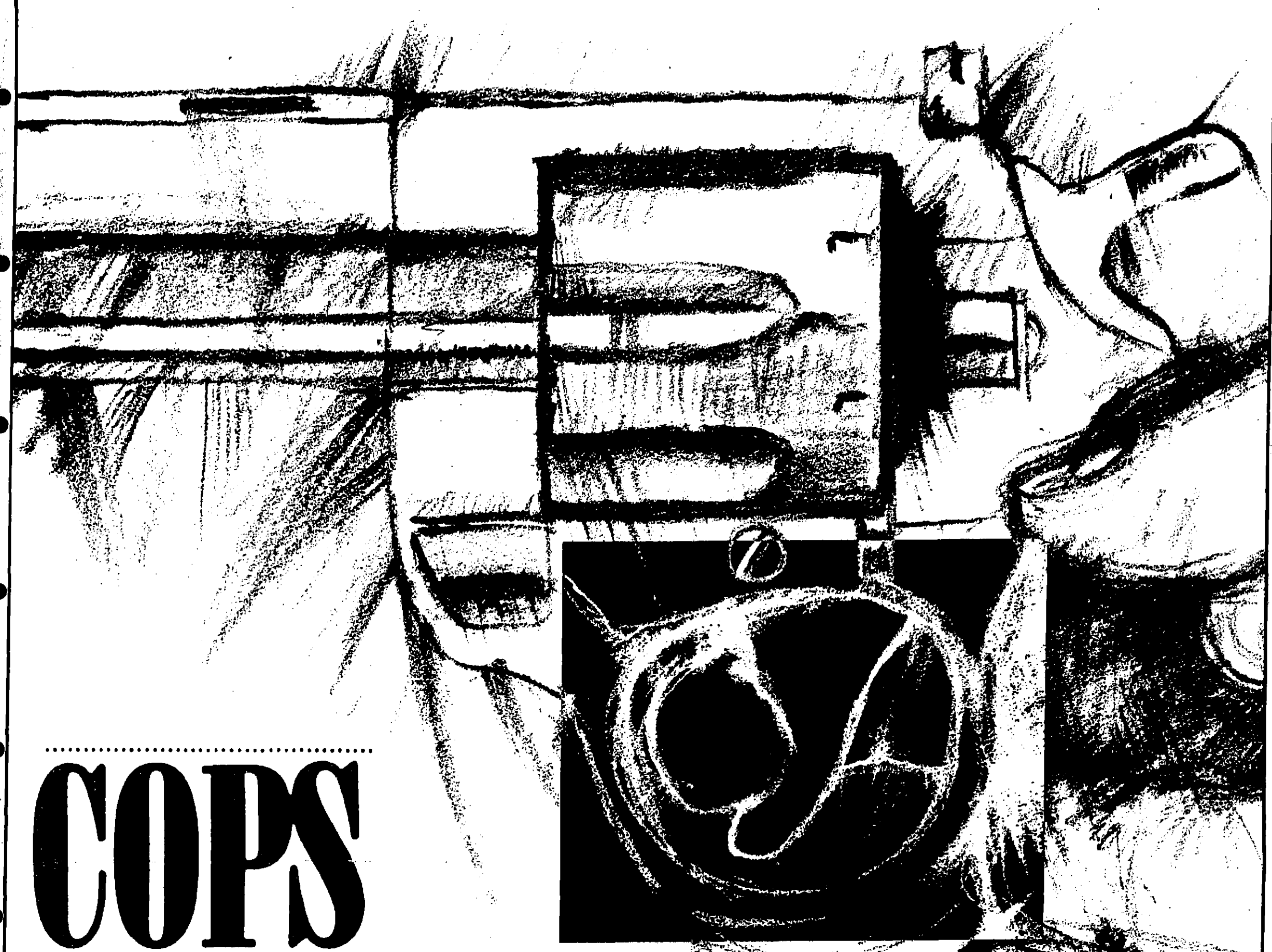

COPS & GUNS

Revolver is a necessary but seldom-used tool of the trade

Art/page design by JEFFREY LAPINSKI



"You're a big man when you've got that gun."

It's a phrase police officers don't hear very often . . . and hear too often.

"It sort of gets under your skin when somebody says something like that," commented one local police officer recently. "It's like they're challenging you."

"They don't understand the role of a gun in police work. They don't understand that the last thing a cop wants to do is have to take that gun out of its holster."

"Some people have the impression police are gun happy . . . that they get a kick out of carrying that gun around on their hips all day. But that's simply not the case. In fact, the opposite is true."

"The basic rule is that you only take the gun out of its holster to protect your own life or to protect somebody else's life."

"Plus, whenever you take the gun out of the holster, you're prepared to use it. It's sort of a last resort."

How often do local law enforcement officers use their guns? Have they ever been shot at? What is the role of the gun in police work?

We decided to ask four local police officers those questions and others. Officers were selected at random from the Novi, Northville and Northville Township police departments as well as the Michigan State Police Post in Northville. No effort was made to seek out officers who may have been involved in shooting incidents at one time or another during their careers.

The following story is comprised of the answers we received when we asked cops to talk about their guns:

LT. ROBERT STARNES
Novi Police Department

Bob Starnes has been an officer with the Novi Police Department more than 20 years. He currently serves as commander of the road patrol.

"Honestly, I don't recall any of our officers . . . wait, I have to retract a little of that. We use our guns when responding to B&E alarms or B&Es in progress. We'll use them for that. But as far as pointing them at somebody, it's strictly taboo."

"The only time our officers use their guns is at the (shooting) range, and even there it's strictly, strictly supervised."

"I just don't recall a time that any of our officers have ever used their guns in the line of . . . No, there was an incident several years ago. Remember the hold-up at the bank on Novi Road near 'Twelve Oaks'? The robber was holding the bank manager hostage. Several officers responded to the call — McGregor, Jelly, and Jelly had his opportunity to fire off a shot and he took it."

"As soon as he fired, the robber threw his gun to the ground and gave up. Released the manager. He apparently didn't expect the officer to shoot."

"That was a case where it was totally justified. Bank robbery. Federal offense. Citizen held captive. Clear shot."

"There was a big embankment behind the robber and the hostage. The only place the bullet could have gone was into the embankment. The one shot the officer took was sufficient to do the job and end the crisis. I'm sure he (the robber) heard the bullet going by him."

"We would never even consider shooting a gun if the bullet might hit a bystander. We don't even fire warning shots. Whenever your shot your gun, the bullet has to go somewhere. If you shoot a round into the air, it's going to come down some place. Even when you shoot at the ground, there's a chance the bullet could hit a rock and ricochet."

"T.V. hypes things up so much. In a one-hour T.V. show, it seems like Don Johnson fires off several hundred rounds. Many officers go through their entire careers without ever firing a shot in the line of duty . . . many without ever taking the gun out of their holsters."

"There's absolutely no horseplay with a gun. Never. You'll never see an officer practicing quick draws. As the commanding officer, if I walk into the squad room and see horseplay with a gun, the officer will be immediately suspended. Guns are dangerous."

"You have to understand police. A gun is nothing more to a police officer than a hammer is to a carpenter. It's a tool of the trade. It's like building a house, you can't do your job without it. At the end of the day, he puts his gun away just like the carpenter puts away his hammer."

"I personally have had my gun out of its holster only once in the line of duty. A few years ago we had a call about some kids . . . not kids, people in their early 20s . . . trying to cash in some money at the Novi Road Big Boy. And they had a gun. I was in a one-man unit and drove over behind the restaurant — and there they were. There was a guy standing there with a gun."

"Obviously, my first thought was to disarm him. I pulled my gun out for a grand total of maybe five seconds. Just long enough to get his gun. Then mine went right back in the holster."

"That's the safest place for it."

SGT. GARY CALLENDER
Northville Police Department

Gary Callender has been an officer with the Northville Police Department for 12 years.

"I've drawn my gun on many occasions. I think all our officers have because you don't know what type of situation you are going to get into, especially on bank alarms or B&Es in progress. Certain instances it's only intelligent to pull the weapon prior to going in, but I've never shot at anyone."

"I've only been shot at once. The call came in to back up Novi police. There was a mental patient with a gun in the woods. I was walking on the railroad tracks on Novi Road, just north of Eight Mile, and the guy took a shot at me. It whizzed by my head. He popped up and threw the gun down so there was obviously no need to neutralize him."

"There wasn't a whole lot I could do to him because his story was that he was shooting at a rabbit and the bullet ricocheted off the creek by my head."

"That was the only time, but once is enough. I spent 13 months in Vietnam so I know what a round sounds like when it goes by your head."

"Sometimes pointing the gun at somebody is an absolute necessity, but we never have it in a cocked position. We train this so there are no accidental misfires. I won't point it at anyone unless I have reason to use lethal force."

"I am a firearms range instructor, and I think work at the range is great. We do night-fire, we do day-fire, we do on-duty, off-duty, shotgun, rifle — whatever weapons we have in this department we train each officer."

"To our department and most others, warning shots are prohibited. The problem with it is if you shoot a warning shot up in the air it has to come down somewhere and, with policemen's luck, it's going to wind up in somebody's head."

"About one percent of what you see on T.V. is maybe true. The best T.V. show was probably Barney Miller. Contrary to popular belief, it's not all glamor. We go on some really ugly rounds like accident runs, death runs, things like that. On T.V., they are involved in a shooting and back on the streets in 10 minutes. In reality, when you shoot at somebody and hit them, you are automatically, without any questions, suspended. They have to have a full investigation before you are cleared."

"One of the craziest shows I ever saw was Adam 12 — they were involved in two or three shootings, a couple of breaking and enterings in progress and an armed robbery, all in a half-hour. But if televi-

sion actually showed what police work is like, you'd be bored. Nobody would watch it."

"Having a gun is a necessity due to the fact I don't know if the 'bad guy' got one. If I knew they didn't have one, I wouldn't wear one."

SGT. JOHN SHERMAN
Northville Township Police

Sgt. John Sherman has been an officer with the Northville Township police department for 10 1/2 years. He currently is in charge of firearm training for the department, officer-in-charge of the special operations team (SOT) and coordinator of the reserve officers training program.

"It would be extremely regrettable if a police officer killed someone with his weapon, but when an officer pulls his firearm, he is doing nothing more than taking the final step toward stopping an aggressive action."

"I have never shot anyone, but I have pulled my firearm — a department-issued Smith and Wesson Model 65 — on a number of occasions."

Continued on 3

the NOVI NEWS

Sports

SCALPED:
Milford's Redskins shut down Novi cagers/5C

PIECE OF CAKE:
Wildcat swimmers stroke past Chelsea/6C

PROGRESS:
Cross-country coach happy with ninth place/7C

TITLE NO. TWO:
Hansen savors 2nd conference tennis title/8C

4C
WEDNESDAY
November 5,
1986

It's close, but Wildcats hang on 12-7

By NEIL GEOGHEGAN
staff writer

Friday's gridiron clash between Novi and Northville illustrated why high school football can be so great. Novi's heart-pounding 12-7 victory was decided on the game's final play, climaxing a contest that had all the ups and downs, struggles, heroics and emotions of most great athletic events.

With just two wins this season, Northville was a heavy underdog with nothing to lose. Coach Darrel Schumacher's squad played its best game of the season, fighting valiantly all evening and gaining a lot of respect along the way.

With just two wins this season, Northville was a heavy underdog with nothing to lose. Coach Darrel Schumacher's squad played its best game of the season, fighting valiantly all evening and gaining a lot of respect along the way.

Friday's gridiron clash between Novi and Northville illustrated why high school football can be so great. Novi's heart-pounding 12-7 victory was decided on the game's final play, climaxing a contest that had all the ups and downs, struggles, heroics and emotions of most great athletic events.

With just two wins this season, Northville was a heavy underdog with nothing to lose. Coach Darrel Schumacher's squad played its best game of the season, fighting valiantly all evening and gaining a lot of respect along the way.

With just two wins this season, Northville was a heavy underdog with nothing to lose. Coach Darrel Schumacher's squad played its best game of the season, fighting valiantly all evening and gaining a lot of respect along the way.



Kurt Schuster (68) provides an escort for Novi quarterback Jeff Tanderys

Everett edges Novi out of spot in grid playoffs

For the second straight season, Howell High School found a way to prevent a fellow Kensington Valley Conference (KVC) school making it into the MHSAA Class A (football) playoffs.

In 1985, the Highlanders handed South Lyon its only loss of the season, denying the Lions a spot in the playoffs. And this year the Highlanders did it again—to Novi. Howell fell two points shy of beating Lansing Everett last Friday, knocking Novi out of the state playoff picture.

For the second straight season, Howell High School found a way to prevent a fellow Kensington Valley Conference (KVC) school making it into the MHSAA Class A (football) playoffs.

In 1985, the Highlanders handed South Lyon its only loss of the season, denying the Lions a spot in the playoffs. And this year the Highlanders did it again—to Novi. Howell fell two points shy of beating Lansing Everett last Friday, knocking Novi out of the state playoff picture.

For the second straight season, Howell High School found a way to prevent a fellow Kensington Valley Conference (KVC) school making it into the MHSAA Class A (football) playoffs.

In 1985, the Highlanders handed South Lyon its only loss of the season, denying the Lions a spot in the playoffs. And this year the Highlanders did it again—to Novi. Howell fell two points shy of beating Lansing Everett last Friday, knocking Novi out of the state playoff picture.

For the second straight season, Howell High School found a way to prevent a fellow Kensington Valley Conference (KVC) school making it into the MHSAA Class A (football) playoffs.

In 1985, the Highlanders handed South Lyon its only loss of the season, denying the Lions a spot in the playoffs. And this year the Highlanders did it again—to Novi. Howell fell two points shy of beating Lansing Everett last Friday, knocking Novi out of the state playoff picture.

For the second straight season, Howell High School found a way to prevent a fellow Kensington Valley Conference (KVC) school making it into the MHSAA Class A (football) playoffs.

In 1985, the Highlanders handed South Lyon its only loss of the season, denying the Lions a spot in the playoffs. And this year the Highlanders did it again—to Novi. Howell fell two points shy of beating Lansing Everett last Friday, knocking Novi out of the state playoff picture.



Scott Pfeiffer looms as one of the future stars on the Wildcat soccer team

Future is bright for Novi kickers

A season-ending loss to Bloomfield Hills Lusher dropped the Novi soccer squad below the 500 mark, but the setback just wasn't that important to Coach Nick Valenti.

Instead of being remembered as the season his team fell a game short of winning at least half its games, Valenti will always recall 1986 as a key year in the process of building the Wildcat soccer program.

A season-ending loss to Bloomfield Hills Lusher dropped the Novi soccer squad below the 500 mark, but the setback just wasn't that important to Coach Nick Valenti.

Instead of being remembered as the season his team fell a game short of winning at least half its games, Valenti will always recall 1986 as a key year in the process of building the Wildcat soccer program.

A season-ending loss to Bloomfield Hills Lusher dropped the Novi soccer squad below the 500 mark, but the setback just wasn't that important to Coach Nick Valenti.

Instead of being remembered as the season his team fell a game short of winning at least half its games, Valenti will always recall 1986 as a key year in the process of building the Wildcat soccer program.

Rec Briefs

MILLIONAIRES PARTY: The Novi High School Athletic Boosters will present a Millionaires' Party on Saturday, Nov. 8, at the Holy Family Church on Meadowbrook Road between Ten Mile and Grand River.

A HIGH-TECH BASKETBALL CLINIC will be held at University of Detroit High School on Tuesday, Nov. 11, at 7 p.m. The high school is located at 8000 South Cambridge, one block south of Seven Mile, between Livernois and Wyoming in Detroit.

THREE-ON-THREE BASKETBALL: The Novi Parks and Recreation Department is now accepting team entries into the three-on-three basketball league in two divisions: 18-and-over and 30-and-over.

EQUIPMENT SALE: The sixth annual used sports and recreation equipment sale will be held Dec. 6 from 10 a.m. to 1 p.m. at Novi Upper Elementary School.

MOTORCYCLE SAFETY: Schoolcraft College's Continuing Education program will offer weekend courses on Motorcycle Safety on Nov. 7 and Dec. 5. The three-day courses are approved by the State of Michigan and include classroom and range instruction for inexperienced motorcyclists of any age.

Milford slows down Wildcat five

By NEIL GEOGHEGAN
staff writer

Ayotte: '... when you take Maloney out of our line-up it's like taking one of our two main pistons out of our engine.'

Novi's basketball squad blew a perfect chance to break away from the four-team race for second place in the Kensington Valley Conference (KVC), dropping a 56-41 decision to Milford last Thursday.

As a result, the Wildcats saw their KVC record drop to 4-4, leaving the battle for the runner-up spot behind uncatchable South Lyon still up in the air.

The Redskins were, as Novi Coach Bill Ayotte noted, the better team on Thursday. But that isn't surprising because Sandy Maloney, the Wildcats' second leading scorer and rebounder, was forced to miss the game with the flu. Without the senior swing player, Novi was restricted both offensively and defensively.

Novi's basketball squad blew a perfect chance to break away from the four-team race for second place in the Kensington Valley Conference (KVC), dropping a 56-41 decision to Milford last Thursday.

As a result, the Wildcats saw their KVC record drop to 4-4, leaving the battle for the runner-up spot behind uncatchable South Lyon still up in the air.

The Redskins were, as Novi Coach Bill Ayotte noted, the better team on Thursday. But that isn't surprising because Sandy Maloney, the Wildcats' second leading scorer and rebounder, was forced to miss the game with the flu. Without the senior swing player, Novi was restricted both offensively and defensively.

Novi's basketball squad blew a perfect chance to break away from the four-team race for second place in the Kensington Valley Conference (KVC), dropping a 56-41 decision to Milford last Thursday.

As a result, the Wildcats saw their KVC record drop to 4-4, leaving the battle for the runner-up spot behind uncatchable South Lyon still up in the air.

The Redskins were, as Novi Coach Bill Ayotte noted, the better team on Thursday. But that isn't surprising because Sandy Maloney, the Wildcats' second leading scorer and rebounder, was forced to miss the game with the flu. Without the senior swing player, Novi was restricted both offensively and defensively.

Bartling claims prize in grid contest

With several "top 20" teams going head to head, it was a tough week for entrants in the Novi News/Northville Record football contest.

But that didn't stop Todd Bartling of Northville from doing an exemplary job. Bartling missed just two games to end up all alone in first place and win the \$15 first prize in the weekly grid game.

With several "top 20" teams going head to head, it was a tough week for entrants in the Novi News/Northville Record football contest.

But that didn't stop Todd Bartling of Northville from doing an exemplary job. Bartling missed just two games to end up all alone in first place and win the \$15 first prize in the weekly grid game.

With several "top 20" teams going head to head, it was a tough week for entrants in the Novi News/Northville Record football contest.

But that didn't stop Todd Bartling of Northville from doing an exemplary job. Bartling missed just two games to end up all alone in first place and win the \$15 first prize in the weekly grid game.

Age 30 to 60? You may save big money on your auto insurance.

Married or single, qualified men and women may save plenty on car insurance with Farmers exclusive 30/60 Auto Package.

Why not check with Farmers Today!

Jim Storm
43320 W. 7 Mile (across from Little Caesar's)
Northville 348-8510

"Don't Procrastinate... Insulate!"
For Greater Energy Savings
Insulation Special \$325
Per 1000 sq. ft. Ceiling
7" Blown Fiberglass (R-19)

JONES
INSULATION & SUPPLIES, INC.
Call 348-9880
Blanket Insulation Available

GET READY FOR WINTER WITH A-1 Transmissions

• FREE ROAD TEST • FREE HOIST CHECK • 100% PARTS & LABOR WARRANTY. WE HONOR ALL COMPETITORS COUPONS AND MOST EXTENDED WARRANTY CONTRACTS.

Exclusive at A-1... NEW FACTORY CLUTCH ASSEMBLIES & RE-BUILTS AVAILABLE

ALL AUTOMATICS AND STICK SHIFTS AND OVERDRIVES

SPECIALTY TRANSMISSION COOLERS

FRONT & REAR BEARINGS

FRONT DRIVE AXLES FOR ALL CARS \$69.95 + PARTS

CUSTOMER ASSURANCE PROGRAM
A-1 Transmissions policies have been and will always be, to allow our customers:

• To be present while transmission or other component is removed from vehicle.
• Watch while transmission or other component is being Custom Rebuilt.

TRANSMISSION PAN \$9.95
Special PLUS-FLUID AND FILTER
MUST PRESENT COUPON FOR OFFER - EXPIRES 11-22-86

A-1 Transmissions
YOUR COMPLETE ONE-STOP DRIVE TRAIN SPECIALISTS
OF LIVONIA, INC.
20595 MIDDLEBELT • NOV1 - 349-3266 LIVONIA 478-5010

NORTHVILLE RECORD AND NOVI NEWS FOOTBALL CONTEST

1st PRIZE \$15
2nd PRIZE \$10
3rd PRIZE \$5

ENTER TODAY...

CONTEST RULES

Take a plain piece of paper and number down the left hand side from 1 to 15.
You will notice that each square below is also numbered from 1 to 15 and each contains a football game to be staged this coming weekend. To complete your entry you must do the following:
(1) After each number on your paper write the name of the sponsor of the corresponding squares.
(2) Following the sponsor's name - write the name of the winning team.
(3) In addition, you must pick the total points scored on the outcome of the game in square 15. This will be used in the case of a tie and then the contestant whose score is closest to the actual score will be declared the winner.

Be sure to write your name, address and phone number plainly on your piece of paper (your entry). In case of a tie, prize money will be split. NOTE: Only ONE ENTRY per HOUSEHOLD family per week. Prize money paid only to name on entry. PLEASE do not enter several times using friends names. Such entries will be disqualified if discovered.
Copies of the contest will be posted at the Northville Record office at 104 W. Main, each week.
Entries should be addressed "Football Contest," Northville Record, 104 W. Main, Northville and must be postmarked or brought to our office no later than 4 p.m. each Friday.
Employees of the Northville Record and The Novi News or sponsoring merchants are not eligible.

Schrader's Home Furnishings Specializing in Country Furnishings 111 N. Center • Northville 348-1838	"We Make Believers" McDonald Ford NEW/USED CARS & TRUCKS 558 W. Seven Mile Northville • 349-1400	Orin Jewelers Inc. FREE EAR PIERCING 101 E. Main • Northville 348-6940	QUALITY PAINTING & PAPERHANGING DECORATING BY DAN WALLPAPER, PAINT, WINDOWS SALES & INSTALLATION DAN OR KAREN 481 W. 7 MILE RD. NORTHVILLE, MI 48161
1. Michigan at Purdue PAUL W. CLANCY, D.D.S., P.C. Office: (313) 348-3650 Res: (313) 455-3755	2. Indiana at Michigan State GREEN'S HOME CENTER 107 N. Center Northville • 348-7110 Mon. - Fri. 9:00 A.M. - 7 P.M. • Sat. 10:00 A.M. - 5:00 P.M.	3. Northwestern at Ohio State TRUCK TIRES 2450 W. 8 Mile at Middlebelt Kentucky Lump Coal 10 lb. Anthracite Coal 13 lb. Coke 15 lb. Phone 474-4922 Hours: M-F 8:30-5:30; Sat 8:30-1:30	4. Iowa at Illinois TWELVE OAKS TIRE CO. 42890 Grand River Novi • 348-9599 Michelle Goodyear • Kelly Springfield USED TIRES Truck Tire Road Service
5. Minnesota at Wisconsin Northville Gallery of Flowers Fresh Flowers For All Occasions Come Visit Our Store For upcoming Holiday Free Delivery 135 E. Cady 349-3811	6. SMU at Notre Dame PIZZA Cutter 340 N. Center St. Ribs • Chicken • Pizza • Pasta For The Best Pizza A Round or Square 348-3333	7. Miami (FLA.) at Pittsburgh NORTHVILLE TRAVEL PLANS Lots of convenient Parking 112 W. Main St. Northville • 348-7200	8. Maryland at Penn State Floor Covering TILE • CARPETING • FORMICA 100's of Samples 145 E. Cady • Northville 349-4480
9. Missouri at Oklahoma Johnny Spot CALL 349-0044 595-4646 QUALITY Carpet & Upholstery Cleaners	10. Washington at Oregon State Mich. State Bears U of M Bears TRADER TOMS Highland Lakes Shopping Center 348-8333	11. California at Arizona State Tie Breaker Game: Score:	12. LSU at Alabama 13. Arkansas at Baylor 14. Florida State at South Carolina 15. Stanford at UCLA - Tiebreaker

Continued on 7

Wildcats hang tough to thwart Northville, 12-7

Continued from 4

they do it right, somebody should get freed up — it was Joe (Miskovich)." Novi took advantage of a fumbled punt just before the half to score the game's first points, and added the second touchdown to take a 12-0 lead early in the third quarter after a poor Northville punt gave them good field position. The Mustangs scored the final points after a long drive midway through the fourth quarter. It all set the stage for the final-second heroics.

"It was probably our best game," Schumacher said. "I was extremely pleased with the way the kids played, but we just couldn't finish it off. Our players are extremely disappointed because they honestly felt they could win the ball game — it was very heartbreaking."

The first quarter went according to plans with Novi moving the ball offensively and stopping Novi cold on defense. But the Cats hurt themselves with penalties and mistakes, and the Mustangs held on. "During that span we sort of got lulled to sleep," Osborne said. "Then all of the sudden things got turned around and the longer the game went on, the more confident they got."

Northville put together a 66-yard drive in the second quarter, with the aid of a roughing the kicker call against Novi. With a first and goal at the 14, Mustang quarterback Scott Stevens tossed an interception to Neil Garry in the end zone. Ironically, it was Garry who was flagged for the roughing penalty that kept the drive alive.

With time running out in the half, Novi got a big break and capitalized. Matt Hubert fumbled a Wildcat punt and Jason Korte pounced on the loose ball at the Northville 43 with less than two minutes remaining. On fourth down, Novi quarterback Jeff Tanderys hit Scott Wladishkin with a clutch 27-yard pass that moved the ball to the 16 with 21 seconds left. Tanderys then connected to flanker Brian Schram on the next play for the T.D.

"We knew when (Novi) gets in close, they like to go to Schram because he has good height and jumping ability," Schumacher said. "I'm convinced we had it defended very well, he was double-teamed and just made a nice play."

Mike McGuffin's point-after attempt was blocked by Jeff Hamilton

and the half ended at 6-0.

Novi scored again in the third quarter after a high snap led to a 17-yard Mustang punt and gave the Wildcats the ball on the Northville 36. Randy Parker snared a 20-yard pass from Tanderys on a third down play and tight end Bill Yankowski caught the touchdown pass over the middle from 13 yards out. Again, the quick Novi strike ended on a sour note as the two-point conversion attempt failed.

The Mustang scoring drive started at their own 25 and was kept alive by a pass interference penalty against the Wildcats. With just less than seven minutes left in the game, Sylvestre bolted into the end zone untouched on a 10-yard quarterback bootleg, then kicked the extra point to narrow the gap to 12-7.

The Northville defense held Novi in check down the stretch and gave the offense possession two more times. With 1:41 left on the clock, the Mustangs started at their own 25 and drove down the field.

Wildcat defender Matt Kamish dropped a potential game-ending interception early in the drive. And Sylvestre kept the drive alive with three clutch pass completions. On fourth-and-11 at the 42, he hit Mike Yard for 30 yards down to the Novi 28. On the next play, Greg Kozler caught a 16-yard sideline pass moving it down to the 12 with 40 seconds left. Hubert then grabbed the third throw, eluded a couple of tacklers and was upended by Wildcat defensive back Dave Senkbell just two yards from victory. "He was upset about the dropped

punt and tried everything humanly possible to score the winning touchdown," Schumacher said about Hubert. "I give the kid a lot of credit."

After an incomplete pass that stopped the clock, Miskovich sacked Sylvestre to end the game.

"Northville had a great night," Osborne said. "To their credit, after we had them 12-0, they never quit. Their defense shut us down and played very well. (Mustang linebacker) Tony Briningstool is an exceptional player."

Mustang runner Mike Yard over-shadowed Novi's 1,000-yard rusher Joel Finzel by gaining 77 yards in 19 carries. Finzel was held below 100 yards for only the second time this season with 61 yards on 23 carries.

Hansen reflects on back-to-back KVC net titles

Looking back, Jim Hansen is very proud of his team's two consecutive Kensington Valley Conference (KVC) titles.

The coach of the Novi Wildcat tennis team is hard-pressed, however, to put one ahead of the other. But Hansen readily admits it's the type of dilemma he doesn't mind facing.

So far, in nearly one and a third seasons of league play, Hansen stands head and shoulders above his Wildcat coaching counterparts with two KVC titles. The only other coach with a title is football coach John Osborne.

"I'm happy for both teams," he said. "This one (1986) had only four players who had a full year of varsity tennis experience — the other six came from the J.V.'s and did an excellent job. We weren't the favorites like we were last season. A year ago (1985), we were expected to win, but sometimes it's very hard to get the first one."

Although it's not a contest between coaches, Hansen's success is an indication of how rarely two KVC championships come along. As any coach will admit, two in a row is very difficult.

Novi's 8-3 overall record and 7-2 league mark for the season are very impressive, but Hansen believed the team was capable of turning out wins like that.

"It's an excellent record, but I thought heading in that we had a chance to do well," he said. "The whole season came down to a win over Milford in a dual meet and finishing first in the KVC Meet. Everybody hit when they had to hit, and we somehow managed to slip by Milford and win (the KVC title)."

Singles players Judy Piotrowicz, Laura Maloney and Kathy Belor were all instrumental in the successful season, especially when tournament time rolled around. Piotrowicz had a fine 10-2 mark against league opponents at second singles and then finished second at second singles in the KVC Meet. For the last two years, the

junior has a combined record of 25-7, a pretty high winning percentage.

"Judy played well for us, but I was counting on her," Hansen said. "She was very consistent and generally a sure bet to help us score points."

Maloney (8-4 mark in KVC) and Belor (7-6) didn't have as impressive numbers, but both peaked at the end of the season to provide some key wins in the drive for the title.

"They both played their best at the end of the year and if it wasn't for either one's efforts, we couldn't have won the title," Hansen pointed out.

The top doubles team of Michele Benoit and Sandy Bragg were without a doubt the league's top team. They grabbed the KVC title at first doubles, went undefeated in league play (11-0) and were the perennial top seed.

"They were one of the best doubles teams in the KVC that I've seen in my three years as coach," Hansen said. The second doubles squad of Kim Dasher and Lisa

Latham were also among the KVC elite and proved it in the league championships. In three sets they upended Milford's top-seeded duo to grab the Wildcats' second flight title. Dasher was 12-0 against KVC opponents and Latham, slowed by injuries much of the campaign, was 6-0.

"Kim had three different partners because of Lisa's injuries and she blended well with all of them," Hansen noted.

Perhaps the biggest surprise was the play of Angel Ianni and Michelle Marckwardt at third doubles. Up until the end of the regular season, these two were rotated in every other meet with Renee Lindow and Lisa Kramer, but came on full time in post season play and staged two key upsets.

"We had a great year because all the players seemed to rise to the occasion when the pressure was really on," Hansen said.

I Can't Believe it's Me!

And it could be you with safe, one-day cosmetic enhancement.

- Specializing in lipo-suction
- Nose reconstruction
- Face lift
- Breast contouring
- Tummy Tucks
- Dermabrasion and chemical peel
- Collagen skin contouring
- Ear, chin and scar correction
- Choose out-patient clinic or hospital treatment
- Insurance accepted in many cases

Grosse Pointe Cosmetic Surgery, P.C.

Dr. John W. Harrison
Board Certified • Member, American Society of Cosmetic Surgeons
For free consultation, call (313) 463-2711

your home this dry?*

Recommended Relative Humidity 35%
Sahara Desert 20%
Death Valley 10%
Average Heated Home 18%

stop winter dryness in your home with an

Aprilaire HUMIDIFIER
M. F. DOWNS ENG. INC.
BIRMINGHAM, MI 642-1882
A & S HEATING & COOLING ROCHESTER, MI 852-5515

SKIS Sale Priced \$29⁹⁵ & up

BOOTS Sale Priced \$19⁹⁵ & up

BINDINGS Sale Priced \$9⁹⁵ & up

Over 4,000 sets of skis, boots, bindings, poles and a whole store of winter clothing at special prices.

Benchmark 477-8116

32715 GRAND RIVER, FARMINGTON Between Farmington Rd. & Orchard Lake
OPEN NOON-8 p.m. M-F
10-5 p.m. SAT. • NOON-5 p.m. SUN.

POLYPROPYLENE UNDERWEAR
Light Weight SALE BUY 1 GET 1 FREE

Leaf Relief
Year End Close Out Specials

ECHO

Model 52
5 H.P. B & S

ECHO PB 210
Reg. 169⁰⁰ While they last **\$129⁰⁰**

FAMOUS GIANT-VAC'S

GIANT-BLO

Parker

30" \$229
36" \$269
36" Heavy Duty \$329

You're in the driver's seat... when it comes to "fine-tuning" your lawn... as you wheel along on your tractor with this professional-model sweeper in tow. Its three-foot wide brushing area equals the cleaning capacity of our largest unit. Its anti-wrap reel assures top performance. And its heavy-duty construction smooths out the roughest terrain. The TRAILLETTE features the E-Z Dump basket (which collapses for compact storage)...and many other Parker extras.

MARK'S SMALL ENGINE
16959 Northville Road Northville 349-3860

In Dearborn WE ARE MICHIGAN

LINDA E. FISHER, PH.D.
Professor of Biological Science and Virus Researcher

"My research keeps me on the leading edge of new discoveries in my field. What I learn in the lab today will be incorporated into my classroom teaching tomorrow."

RICHARD ROEHL, PH.D.
Professor of Economics and Energy Policy Researcher

"It is the interdisciplinary collegial spirit among faculty and students at UM-D that makes teaching and research both exciting and rewarding. Here we have the resources of a great university and the environment of a small college."

AT THE UNIVERSITY OF MICHIGAN-DEARBORN, our faculty is our most important resource. Whether advancing the frontiers of knowledge in the lab or teaching that knowledge in the classroom, the goal is always excellence. Accept the challenge at The University of Michigan-Dearborn.

um The University of Michigan-Dearborn
Office of Admissions
Dearborn, Michigan 48128-1491
(313) 593-5100

* The University of Michigan-Dearborn is an affirmative action/nondiscriminatory institution.

drapery-boutique

**fashion, selection
and value always
at drapery boutique**

SAVE 20% to 75% OFF
from

- Bedspreads • Comforters • Sheets • Pillows
- Custom Draperies • Vertical Blinds • Mini Blinds
- Pleated Shades • Window Shades • Rugs
- Shower Curtains • Towels • Bath Accessories
- Tablecloths • Wallpaper • Carpets • Furniture
- Lamps • Accessories • etc., etc. and much more!

Ready to go... Take with

VERTICAL BLINDS

"TAKE WITH"
84" WIDE X 84" HIGH
FITS 6' DOORWALL PROPERLY
Ready to go — hang today!

\$5488 TAKE WITH PVC

COMPARE AT: \$24000

IN STOCK! 109" W x 84" H
FITS 8' DOORWALL

\$7888 PVC WHITE-IVORY
TAKE WITH

COMPARE AT: \$30000

DISCOUNT PATTERN	76%	77%	75%
84W x 84H - FITS 6' Doorwall	Capri Fabric \$6888	Spicer Fabric \$8888	Rib Curve PVC \$7288
109W x 84H - FITS 8' Doorwall	\$8888	\$11788	\$8888

Visit our complete showroom of "In-Stock"
Ready-to-go "Take With Verticals"
NO FREIGHT OR HANDLING CHARGE

never knowingly undersold Since 1969

drapery boutique always offers exceptional values!

SPECIAL ORDER

Wallpaper

47% off

47% off 150 selected Special Order books. 40% off all other Special Order books in our library. Coupon must be presented at time of order only. No charges accepted. Min. order \$50.00 at sale price, otherwise discount is only 35%. Freight and Handling added. Offer expires Sat. November 30th, 1986. Our library consists of over 1200 famous books and companies.

Wallpaper fabrics 50% off.

OFFER BEGINS THURS.
NOVEMBER 4, 1986 THRU
SATURDAY, NOVEMBER 30, 1986

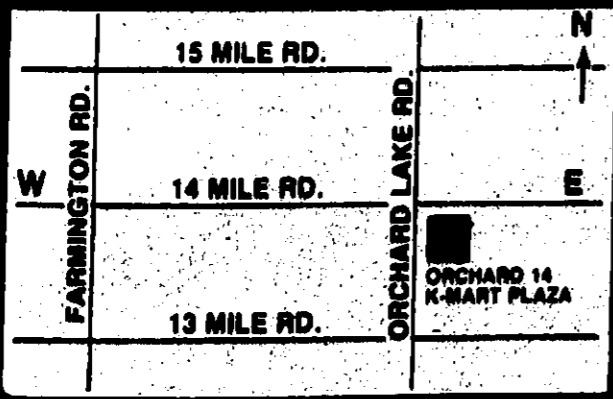

ORCHARD & 14 MILE CENTER
30858 Orchard Lake Road
Farmington Hills
(313) 626-4313
Daily 9:30-6:00
Mon & Thurs 9:30-8:30
Open Sun 12:00-4:00

GRAND RIVER & HAGGERTY Pepper Square
39253 Grand River
Farmington Hills
(313) 478-3133
Daily 9:30-6:00
Mon & Thurs 9:30-8:30
Open Sun 12:00-4:00

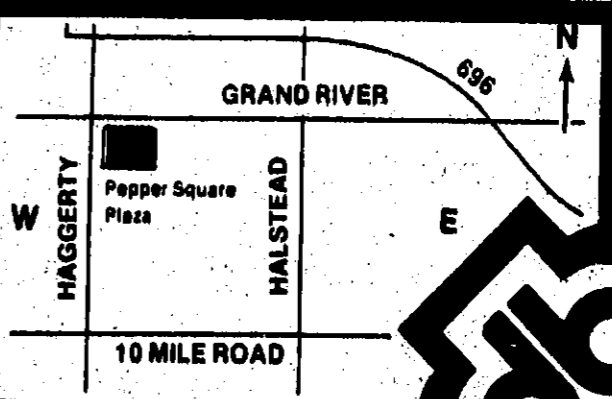

Fashion with Value Always!

drapery boutique



drapery-boutique

PAGE 2

never knowingly undersold

Since 1969

we've got your windows covered!

FREE LINING WITH THE PURCHASE OF **CUSTOM DRAPERIES**

Select any of our "IN STOCK" drapery fabrics and receive Free Lining with the purchase of Custom Draperies.

Styling With Imagination

SHEERS
Per Yard and up
\$3.88

ANTIQUE SATINS
Per Yard and up
\$6.88

CASEMENTS
Per Yard and up
\$8.88

DESIGNER PRINTS
Per Yard and up
\$10.88

You'll love the beauty of your custom draperies, at a savings that would make Scrooge reach for his change purse.

All previous orders excluded. All fabrics sold "as is" basis.

PLEATED SHADES

- SOLARE 65%
- LOUVER DRAPE 65%
- VERASOL 1" and 1/2" 60%
- GARBER PLEAT 60%
- DUETTE 1" and 1/2" 55%

newest fashion in window decor

NO FREIGHT • NO HANDLING CHARGES

Wood Horizontal 1" & 2" Blinds
SAVE 70%

A.C. Woven Woods
SAVE 50%

Roman Fold Design

NO FREIGHT • NO HANDLING CHARGES

Window Shades
SAVE UP TO 47%

Blackout-Insulated Fiberglass

White	Ivory	Champagne
37 1/4 x 6 25.00	46 1/4 x 6 34.00	55 1/4 x 6 49.00
73 1/4 x 6 59.00		

NO FREIGHT • NO HANDLING CHARGES

CONCORD 1" Mini Blinds **SAVE 75% OFF ALL SIZES**

NO FREIGHT • NO HANDLING CHARGES

Widths up to 112"	23"	29"	36"	48"	62"	72"
42	16.75	20.00	24.00	30.50	39.25	44.50
48	18.25	21.75	26.50	33.75	43.50	49.25
54	19.75	23.75	29.00	37.00	47.50	54.25
60	21.50	25.75	31.50	40.25	51.75	59.00

This chart reflects net prices after 75% discount

NO FREIGHT • NO HANDLING CHARGES

BALI 1" CLASSIC Blinds **70% OFF ALL SIZES**

108 Designer Colors

NO FREIGHT • NO HANDLING CHARGES

Widths up to 142"	23"	29"	36"	48"	62"
42	20.10	24.00	28.80	36.60	47.10
48	21.90	26.10	31.80	40.50	52.20
54	23.70	28.50	34.80	44.40	57.00
60	25.80	30.90	37.80	48.30	62.10

This chart reflects prices after 70% discount

NO FREIGHT • NO HANDLING CHARGES

ORCHARD & 14 MILE CENTER

custom drapery designs - our specialty!
drapery boutique

GRAND RIVER & HAGGERTY ROADS
Pepper Square Plaza

drapery-boutique

PAGE 3

never knowingly undersold

Since 1969

we've got stacks & stacks of Super deals!

SAVE UP TO 65%

"FAN FARE" Bedspreads & Comforters

"Another Dakotah Value"

	Compare	db	Compare	db
TWIN	\$370.00	\$159 ⁰⁰	\$300.00	\$139 ⁰⁰
FULL	420.00	183 ⁰⁰	390.00	163 ⁰⁰
QUEEN	490.00	209 ⁰⁰	450.00	179 ⁰⁰
KING	520.00	224 ⁰⁰	490.00	204 ⁰⁰

Bedspreads & Comforters **SAVE UP TO 75%**

1st. quality in stock

YOUR CHOICE \$69⁸⁸ (TWIN or FULL)

YOUR CHOICE \$79⁸⁸ (QUEEN or KING)

Compare TWIN \$250-\$275, FULL \$250-\$325, QUEEN \$275-\$350, KING \$325-\$400

Limited quantities and sizes 150 pieces

S.T. DIAGON BEDSPREAD
—angelled design—
—new custom extra fiberfill—

	Compare	db
TWIN	\$165.00	\$77 ⁸⁸
FULL	225.00	98 ⁸⁸
QUEEN	255.00	118 ⁸⁸
KING	285.00	128 ⁸⁸

Ultra Comforters —Super Buys—

Reversible - Deluxe Extra Fill - Polyester Fiberfill - Rich Fashion Colors & Designs

	COMPARE	db
TWIN	\$79.00	\$25 ⁸⁸
FULL/QUEEN	89.00	36 ⁸⁸
KING	99.00	44 ⁸⁸

Special Savings

100% polyester fiberfill. Rich textured colors. Frame design stitch...

	COMPARE	db
TWIN	\$90.00	\$28 ⁸⁸
FULL	110.00	34 ⁸⁸
QUEEN	125.00	39 ⁸⁸
KING	135.00	45 ⁸⁸

Soft and Sensuous **Flannel - Suede Solid Color - Reversible Comforters**

SAVE UP TO 70%

ORCHARD & 14 MILE CENTER

our values on comforters are superb!
drapery boutique

GRAND RIVER & HAGGERTY ROADS
Pepper Square Plaza

drapery boutique

VERTICAL BLINDS

PAGE 4

Visit our unique Design Studio - our huge selection of Vertical Blind Lower materials will meet your desired window decor with direct factory savings!

Compare our Quality, Selection, Service and Price before buying.
No freight - No Handling Charges

SAVE UP TO 78%
NO FREIGHT
NO HANDLING CHARGES

DISCOUNT	75% all sizes	75% all sizes	75% all sizes	75% all sizes	78% all sizes	78% all sizes
Pattern & Style	Shade Cloth	Canada	Kirk	Suede I & II	Cedar	Clouds
Width & Height	Compare	Compare	Compare	Compare	Compare	Compare
47 x 48 1 Way	\$163	\$40 ⁷⁵	\$191	\$47 ⁷⁵	\$136	\$34 ⁰⁰
72 x 84 1 Way	\$313	\$78 ²⁵	\$416	\$104 ⁰⁰	\$273	\$68 ²⁵
109 x 84 1 Way	\$465	\$116 ²⁵	\$623	\$155 ⁷⁵	\$404	\$101 ⁰⁰
100 x 84 2 Way	\$422	\$105 ⁵⁰	\$583	\$142 ⁰⁰	\$365	\$91 ²⁵
119 x 84 2 Way	\$495	\$123 ⁷⁵	\$667	\$166 ⁷⁵	\$430	\$107 ⁵⁰
84" W x 84" H one way draw fits 6' doorway	Compare \$360 db \$89 ⁸⁸	Compare \$483 db \$120 ⁷⁵	Compare \$483 db \$120 ⁷⁵	Compare \$314 db \$78 ⁵⁰	Compare \$395 db \$86 ⁹⁰	Compare \$314 db \$68 ⁸⁸

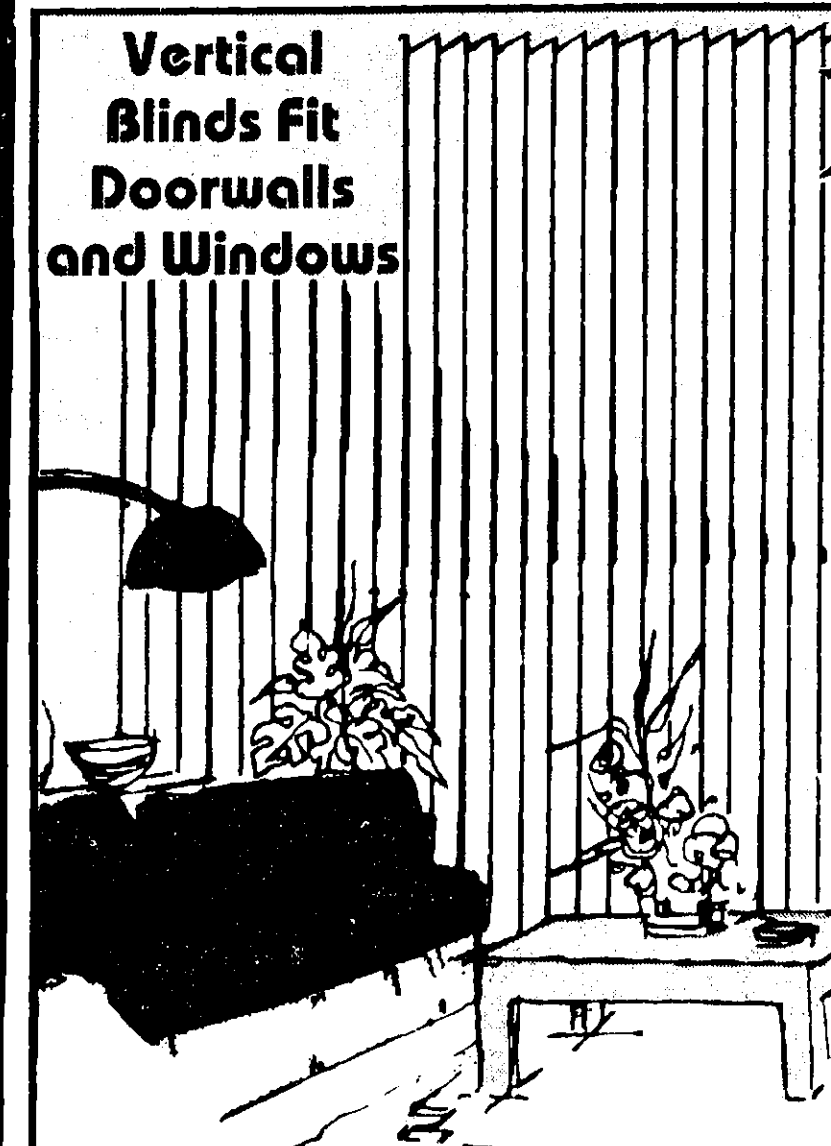

Vertical Blinds Fit Doorwalls and Windows

SAVE 65%
2" WIDE VANES!
CUSTOM VERTICAL BLINDS

Selected P.V.C. - Aluminum Decorator Shade Fabrics
The look of drapery - the new fashion accent!
All other sizes at 65% Savings

DISCOUNT	65% All Sizes	65% All Sizes	65% All Sizes
SIZE	P.V.C. C-Curve	Aluminum Curve	Shade Cloths
Width & Height	Compare	Compare	Compare
21 x 48 one way	\$87	\$30 ⁴⁵	\$111
35 x 48 one way	\$108	\$37 ⁰⁰	\$133
47 x 48 one way	\$136	\$47 ⁰⁰	\$170
60 x 48 one way	Compare \$165 \$57 ⁷⁵	Compare \$165 \$57 ⁷⁵	Compare \$207 \$72 ⁴⁵

READY-MADE IN STOCK 1" ALUMINUM MINI* BLINDS by BALI

SIZE	db price	SIZE	db price	SIZE	db price
23 x 42	\$14 ⁸⁸	31 x 64	\$26 ⁸⁸	36 x 64	\$29 ⁸⁸
23 x 64	\$21 ⁸⁸	32 x 64	\$26 ⁸⁸	48 x 64	\$36 ⁸⁸
27 x 64	\$24 ⁸⁸	33 x 64	\$27 ⁸⁸	60 x 64	\$46 ⁸⁸
29 x 64	\$25 ⁸⁸	34 x 64	\$27 ⁸⁸		
30 x 64	\$25 ⁸⁸	35 x 64	\$28 ⁸⁸		

*NO FREIGHT
*NO HANDLING CHARGES
*White and Vanilla

IN STOCK TAKE WITH VERTICAL BLINDS
Visit Our Complete In-Stock, Take-With Selection!

DISCOUNT	78%	78%	77%	75%	78%	78%
PATTERN	Capri	Clouds	Spicer	Kirk	Macrame Natural	Alb Curve P.V.C.
SIZE	Compare	Compare	Compare	Compare	Compare	Compare
84 w x 84 h one way draw left or right Fits 6' doorway	\$314	\$68 ⁸⁸	\$314	\$68 ⁸⁸	\$385	\$88 ⁸⁸
109 w x 84 h one way draw left or right Fits 6' doorway	\$404	\$88 ⁸⁸	\$404	\$88 ⁸⁸	\$510	\$117 ⁸⁸

OUR VERTICAL BLIND PRICES...ARE LIKE BUYING WHOLESALE!

drapery boutique

WE'VE GOTCHA COVERED ON VERTICAL BLINDS

PAGE 5

COMMERCIAL BIDS for Vertical & Horizontal Blinds and Draperies
Please call 855-5144 Ask for Mr. Bob Pietila

Compare our Quality, Selection, Service and Price before buying.
No freight - No Handling Charges

Since 1969
SAVE UP TO 78%
NO FREIGHT
NO HANDLING CHARGES

OUR VERTICAL BLIND PRICES...ARE LIKE BUYING WHOLESALE!

Patterns	Aluminum 20 Fashion Colors	Macrame 20 Elegant Patterns/Colors	P.V.C. Flat White, Ivory, Tan	Quebec Fabric No. 14 & 15
Discount	Save Up To 78%	Save All Sizes 75%	Save Up To 73%	Save All Sizes 75%
Width & Height	Compare	Compare	Compare	Compare
35 x 84 1 Way	\$123	\$30 ⁷⁵	\$324	\$81 ⁰⁰
47 x 84 1 Way	\$157	\$39 ²⁵	\$468	\$117 ⁰⁰
59 x 84 1 Way	\$190	\$47 ⁵⁰	\$578	\$144 ⁵⁰
72 x 84 1 Way	\$225	\$49 ⁸⁸	\$688	\$172 ⁰⁰
109 x 84 1 Way	\$333	\$83 ²⁵	\$963	\$240 ⁷⁵
84" W x 84" H one way draw fits 6' doorway	Compare \$259.00 db \$59 ⁸⁸	Compare \$760.00 db \$187 ⁵⁰	Compare \$248.00 db \$66 ⁹⁶	Compare \$483.00 db \$120 ⁷⁵

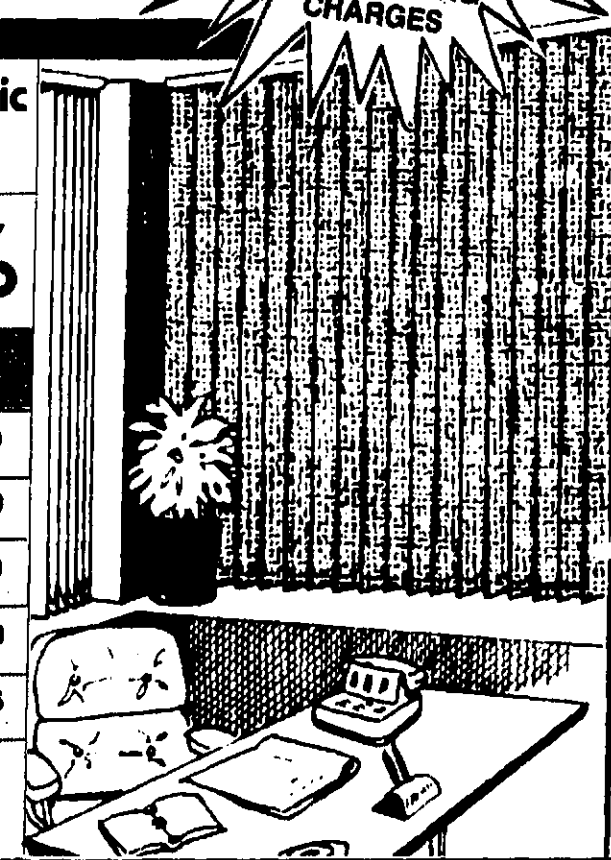

Compare Our Quality, Selection, Service and Price Before Buying. There are NO FREIGHT or HANDLING CHARGES. We use a Heavy Duty Tracking System with self-aligning clutch memory system with a 36-month limited warranty. Measuring, Installation & Design Service at Nominal Charge.

and we have more, and more special values to offer on custom Vertical Blinds SAVE UP TO 78%

SPECIAL PURCHASE SAVE 77% ALL SIZES
"MACRAME" NATURAL CUSTOM VERTICAL BLINDS
COMPARE \$483
85w x 84h ONE WAY Fits 6' doorway
\$111⁰⁹
COMPARE \$623
109w x 84h ONE WAY Fits 6' doorway
\$143²⁹
All other custom sizes at equal savings!

Patterns	Capri Fabric Unique texture & weave	Spicer SHADE CLOTH Most famous cloth	S-Curve P.V.C. The look of draperies
Discount	Save All Sizes 78%	Save All Sizes 77%	Save All Sizes 75%
Width & Height	Compare	Compare	Compare
47 x 48 1 Way	\$136	\$29 ²²	\$172
59 x 84 1 Way	\$229	\$50 ³⁰	\$296
72 x 84 1 Way	\$273	\$60 ⁰⁶	\$341
97 x 84 1 Way	\$356	\$78 ³²	\$449
109 x 84 1 Way	\$404	\$88 ⁸⁸	\$510
84" W x 84" H one way draw fits 6' doorway	Compare \$314.00 db \$68 ⁸⁸	Compare \$395.00 db \$90 ⁸⁵	Compare \$287.00 db \$71 ⁷⁵

OUR VERTICAL BLIND PRICES...ARE LIKE BUYING WHOLESALE!

ORCHARD & 14 MILE CENTER

drapery boutique

GRAND RIVER & HAGGERTY ROADS
Pepper Square Plaza



drapery-boutique

PAGE 6

never knowingly undersold

Since 1969

we've got stacks & stacks of bedcovers!

"SATIN CLOUDS" CUSTOM BEDSPREAD

the sensuous romantic look!



NEW

NEW

SAVE **30%**

FULL
QUEEN
KING

Compare **\$310.00**
db **\$219⁸⁸**
\$239⁸⁸
\$249⁸⁸

DYNASTY

•uniquely quilted
•outline quilted •70% polyester fiberfill •Hi-tech colors •solid colors

BEDSPREADS		COMFORTERS	
Compare	db	Compare	db
TWIN \$97.00	\$75⁸⁸	TWIN \$83.00	\$63⁸⁸
FULL 130.00	\$99⁸⁸	FULL 113.00	\$86⁸⁸
QUEEN 169.00	\$129⁸⁸	QUEEN 139.00	\$106⁸⁸
KING 195.00	\$149⁸⁸	KING 165.00	\$126⁸⁸

BENTLEY

•outline-quilted
•custom fiberfill
•graceful paint stroke motif
•out-standing design

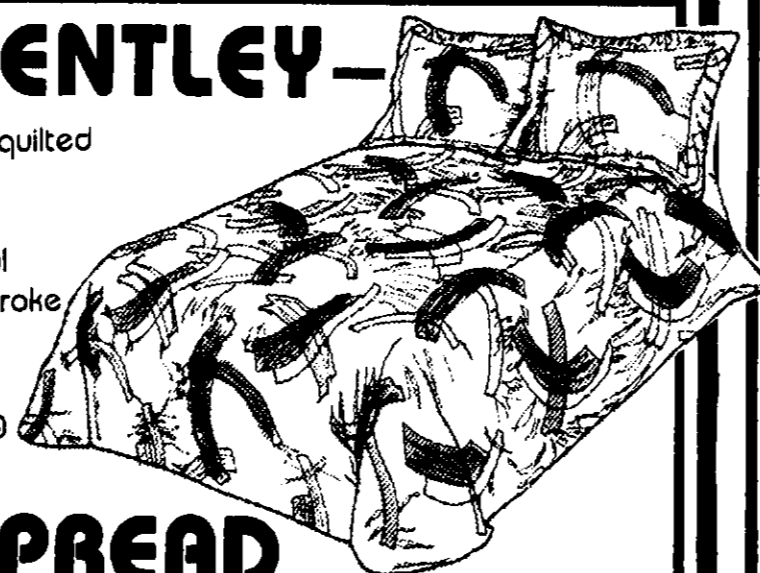

BEDSPREAD

	COMPARE	db
TWIN	\$120.00	\$79⁸⁸
FULL	130.00	\$99⁸⁸
QUEEN	169.00	\$129⁸⁸
KING	195.00	\$149⁸⁸

Duvet Comforter & Blanket Covers Available in stock, Twin, Full, Queen, King Sizes In assorted styles and colors.

IN STOCK

our values on comforters are superb!

ORCHARD & 14 MILE CENTER

drapery boutique

GRAND RIVER & HAGGERTY ROADS
Pepper Square Plaza



Fashion with Value Always!

drapery-boutique

PAGE 7

never knowingly undersold

Since 1969

bath decor and "necessary accents"



Cannon Royal Family

of Fine Quality



Terry Towels
Super Values
Fashion Colors

ROYAL CLASSIC TERRY	ROYAL PRECISION RIBBED TERRY	ROYAL TOUCH SOFT TERRY	MAGNIFICENCE TERRY EXTRA LARGE TOWELS
Save UP TO 43%	Save UP TO 36%	Save UP TO 34%	Save UP TO 31%
Compare	db	Compare	db
Bath \$12.00	\$6⁸⁸	Bath \$12.00	\$7⁸⁸
Hand 8.00	5⁴⁸	Hand 9.00	5⁸⁸
Wash 3.50	2⁶⁸	Wash 4.50	2⁸⁸
Fingertip 3.50	2⁸⁸	Fingertip N/A	—
Tub mat 18.00	12⁸⁸	Tubmat N/A	—
Bath-Sheet 30.00	18⁸⁸	Bath-Sheet N/A	—
		Bath-Sheet 31.00	23⁸⁸
			Bath-Sheet N/A

NOSTALGIA COTTON MATTRESS PADS

•100% COTTON COVER •SLIGHTLY IMPERFECT
•BONDED POLYESTER FIBERFILL

	Compare	db		Compare	db
TWIN	\$28.00	\$14⁸⁸	QUEEN	\$40.00	\$21⁸⁸
FULL	\$35.00	\$18⁸⁸	KING	\$48.00	\$28⁸⁸



FAMOUS "SERENE" Sleep Pillows

•100% Celanese Fortrel fiberfill
•Hypo-non-allergenic

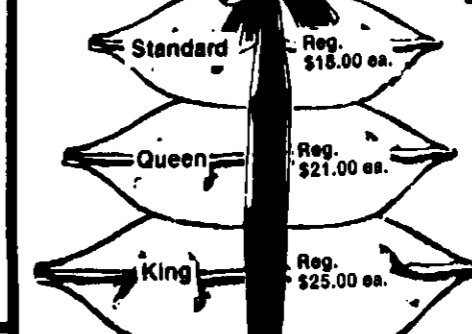

	Compare	db
STANDARD	\$18.00	\$13⁸⁸
QUEEN	21.00	\$15⁸⁸
KING	25.00	\$18⁸⁸

Shower Curtains

SAVE **25%-50%**
Special Select Group

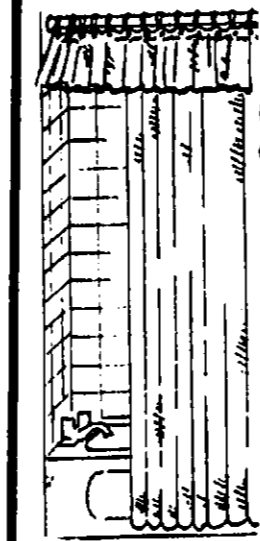

VINYLS
FABRICS
COTTONS

Classic Lucite SLEEK 'N SLIM BATH ACCESSORIES

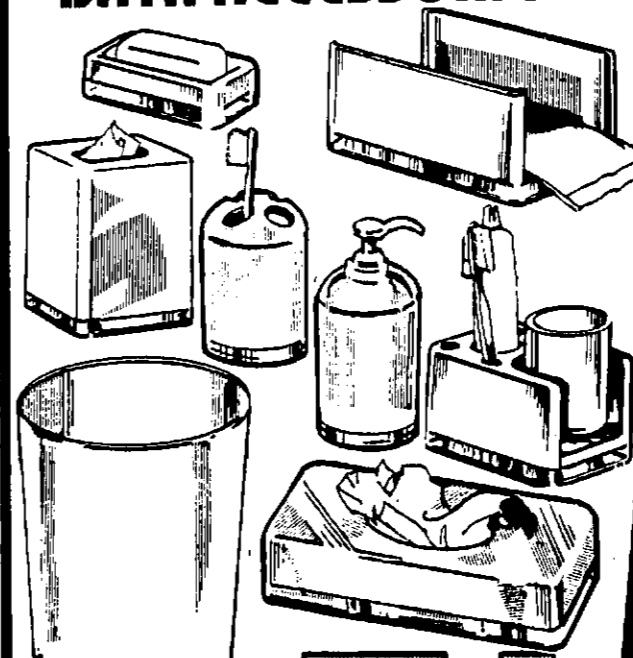

	Compare	db
Basket	\$20.00	\$15⁸⁸
Tissue	\$13.00	9⁸⁸
Boutique	\$12.00	8⁸⁸
Caddy	\$10.00	7⁸⁸
Toothbrush Holder	\$10.00	7⁸⁸
Lotion	\$7.50	5⁸⁸
Soap dish	\$7.00	5⁴⁸
Tumbler	\$4.00	2⁸⁸

BATH RUGS AND WALL to WALL CARPETS

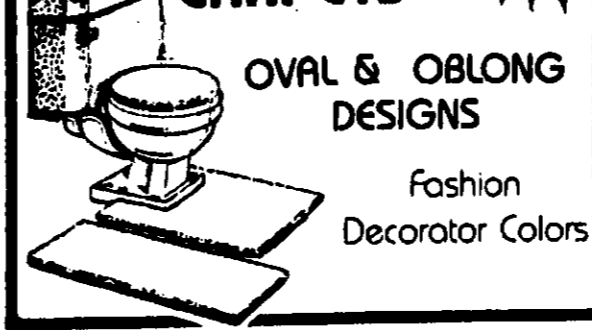

SAVE UP TO **40%**
Fashion Decorator Colors

"For the ultimate in sleep comfort"

Grand-flannel sheets from Fab

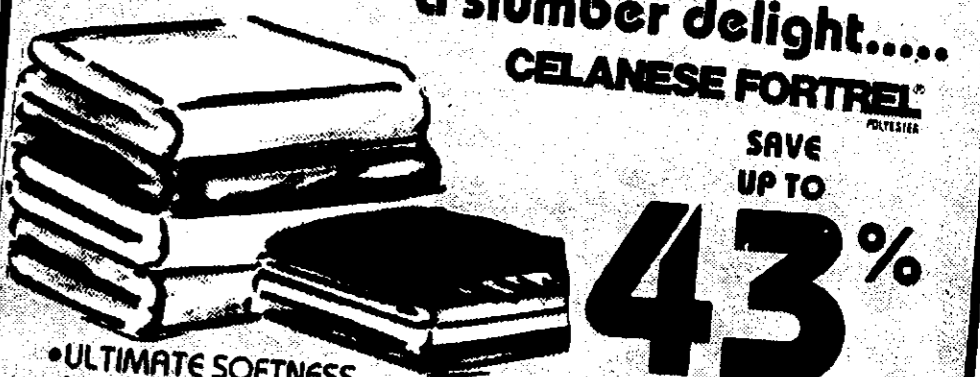

CELANESE FORTREL

SAVE UP TO **43%**

•ULTIMATE SOFTNESS
•NON ALLERGENIC
•NO PILLING OR SHEDDING

	compare	db
TWIN	\$19.00	\$10⁸⁸
FULL	\$22.00	\$14⁸⁸
QUEEN	\$28.00	\$17⁸⁸
KING	\$33.00	\$20⁸⁸
STANDARD CASES	\$14.00 pair	\$9⁸⁸ pair
KING CASES	\$17.00 pair	\$12⁸⁸ pair

Shop Our Unique Bath Shop For Big Selection & Low Prices

ORCHARD & 14 MILE CENTER

drapery boutique

GRAND RIVER & HAGGERTY ROADS
Pepper Square Plaza



Fashion with Value Always!

drapery boutique

never knowingly undersold

"Bargains Galore"

Colored Shower Curtain Magnetic Liners

Compare at **\$6.99**

drapery boutique COUPON

SHOWER CURTAIN MAGNETIC LINERS

\$2.88

LIMIT 3
Present coupon at purchase only. Offer expires Sat., Nov. 30, 1988.

Wallpaper
— In Stock —

Mix or Match any Number of rolls in any combination of patterns with savings to 60% on our everyday low price

drapery boutique COUPON

In Stock Wallpaper Rebate

Total Purchase Instant Rebate
up to \$100.00 5%
up to \$150.00 10%
up to \$250.00 15%
up to \$300.00 20%

Present coupon at purchase only. Offer expires Sat., Nov. 30, 1988.

White Zippered Pillow Protectors

Polyester-Cotton-Washable
Protect your pillows.

drapery boutique COUPON

ZIPPERED PILLOW PROTECTORS

Compare at \$2.99
Standard \$2.00
Queen \$2.49
King \$2.99

Present coupon at purchase only. Offer expires Sat., Nov. 30, 1988.

SHADOW BOX WALLSHELF
— Clear Lucite —

two heavy brilliant cubes, 12" square for use in any room.

Compare at \$29.00

drapery boutique COUPON

SHADOW BOX WALL SHELF
— Clear Lucite —

\$17.88

LIMIT 3
Present coupon at purchase only. Offer expires Sat., Nov. 30, 1988.

Wallpaper Clear Edge Guards

4' and 8' sizes
Protect your corners

drapery boutique COUPON

Wallpaper Edge Guards

4' size \$1.88
8' size \$3.88

Present coupon at purchase only. Offer expires Sat., Nov. 30, 1988.

CLEAR LIBRARY MAGAZINE RACK
Wall hang or place 2 units together for floor use.

Compare Single Unit \$15.00

drapery boutique COUPON

CLEAR LIBRARY MAGAZINE RACK

\$9.88

Present coupon at purchase only. Offer expires Sat., Nov. 30, 1988.

BLANKET & COMFORTER DUVET COVERS

ASST SOLID COLORS AND HI-TECH DESIGNS

Compare TWIN \$35.00
Compare QUEEN \$42.00
Compare FULL \$37.50
Compare KING \$47.50

drapery boutique COUPON

BLANKET & COMFORTER DUVET COVERS

\$19.88

Present coupon at purchase only. Offer expires Sat., Nov. 30, 1988.

Lucite clear 2 SHELF UNIT WITH TOWEL HOLDER

COMPARE \$24.00

drapery boutique COUPON

LUCITE CLEAR 2 SHELF UNIT

\$15.88

LIMIT 3
Present coupon at purchase only. Offer expires Sat., Nov. 30, 1988.

"Bargains Galore"

Since 1969

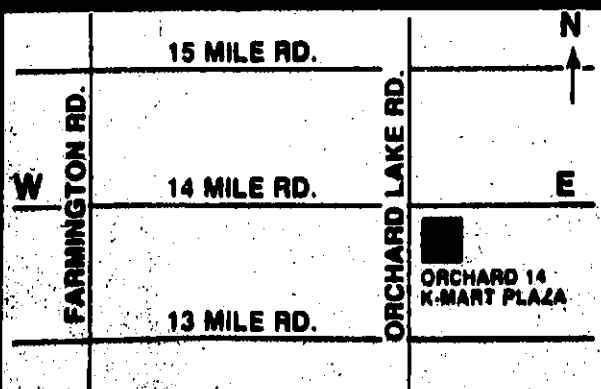

ORCHARD & 14 MILE CENTER

30858 Orchard Lake Road
Farmington Hills
(313) 626-4313
Daily 9:30-6:00
Mon & Thurs 9:30-8:10
Open Sun 12:00-4:00

GRAND RIVER & HAGGERTY

39253 Grand River
Farmington Hills
(313) 478-3133
Daily 9:30-6:00
Mon & Thurs 9:30-8:30
Open Sun 12:00-4:00

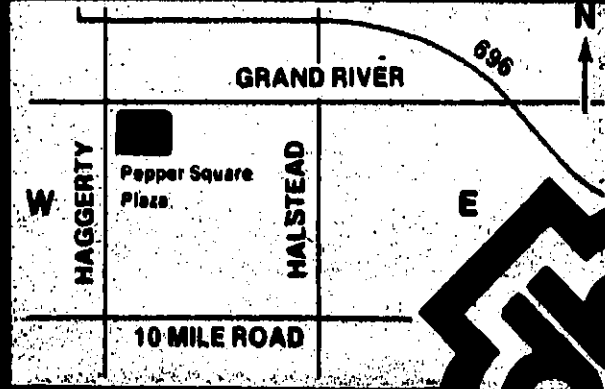

drapery boutique





Herman's we are sports
WORLD OF SPORTING GOODS

Sale now through Nov. 15, 1986

ANNUAL SKI MARATHON SALE

We Welcome the American Express Card



SAVE 20% TO 40%



ENTIRE STOCK OF
DOWNHILL SKIS REDUCED

\$30 TO \$65 OFF reg. and orig. prices

• ROSSIGNOL • K2 • HEAD • FISCHER • DYNASTAR

ENTIRE STOCK OF MEN'S AND WOMEN'S
SKI BOOTS REDUCED

\$20 TO \$40 OFF reg. and orig. prices

• NORDICA
• SALOMON
• RAICHLE

ENTIRE STOCK OF MEN'S AND WOMEN'S
SKIWEAR REDUCED

20% TO 25% OFF reg. and orig. prices

• WHITE STAG
• SLALOM • GERRY
• ALPINE DESIGNS
• PROFILE • SNUGLER
• HERMAN'S

• EVERY SKI PARKA • EVERY SKI VEST • EVERY BIB PANT
• EVERY STRETCH PANT • EVERY SKI SWEATER
• EVERY SKI SUIT • EVERY CROSS-COUNTRY SHELL

herman's
WORLD OF SPORTING GOODS

ANNUAL SKI

SAVE 20%

ENTIRE STOCK OF DOWNHILL SKI PACKAGES

All Packages Include:
• SKIS • POLES
• BINDINGS
(Mounting extra)

Choose from a wide variety of models from:
• ROSSIGNOL • K2 • HEAD • FISCHER • DYNASTAR
Packages for all levels of skiing ability: beginning, intermediate and expert.

**EVERY BINDING
IN OUR STOCK**

Beginning, intermediate, advanced.
• SALOMON • TYROLIA

ENTIRE STOCK OF CROSS-COUNTRY SKI PACKAGES

All Packages Include:
• SKIS • BOOTS
• BINDINGS • POLES
(mounting extra)

• JARVINEN • TRAK • ROSSIGNOL • FISCHER

**ENTIRE STOCK OF CAR RACKS AND
SKI LUGGAGE!** Assorted racks plus
ski, boot, cargo bags and fanny packs. Hurry!

**COMPLETE SKI TUNE-UP
AND MOUNTING SPECIAL**
Purchase any ski package and receive all this...
• Expert ski tune-up • Hot wax • Set up edges, tip, tail
• Personalized ski engraving
our reg. low price, \$22.....NOW \$15

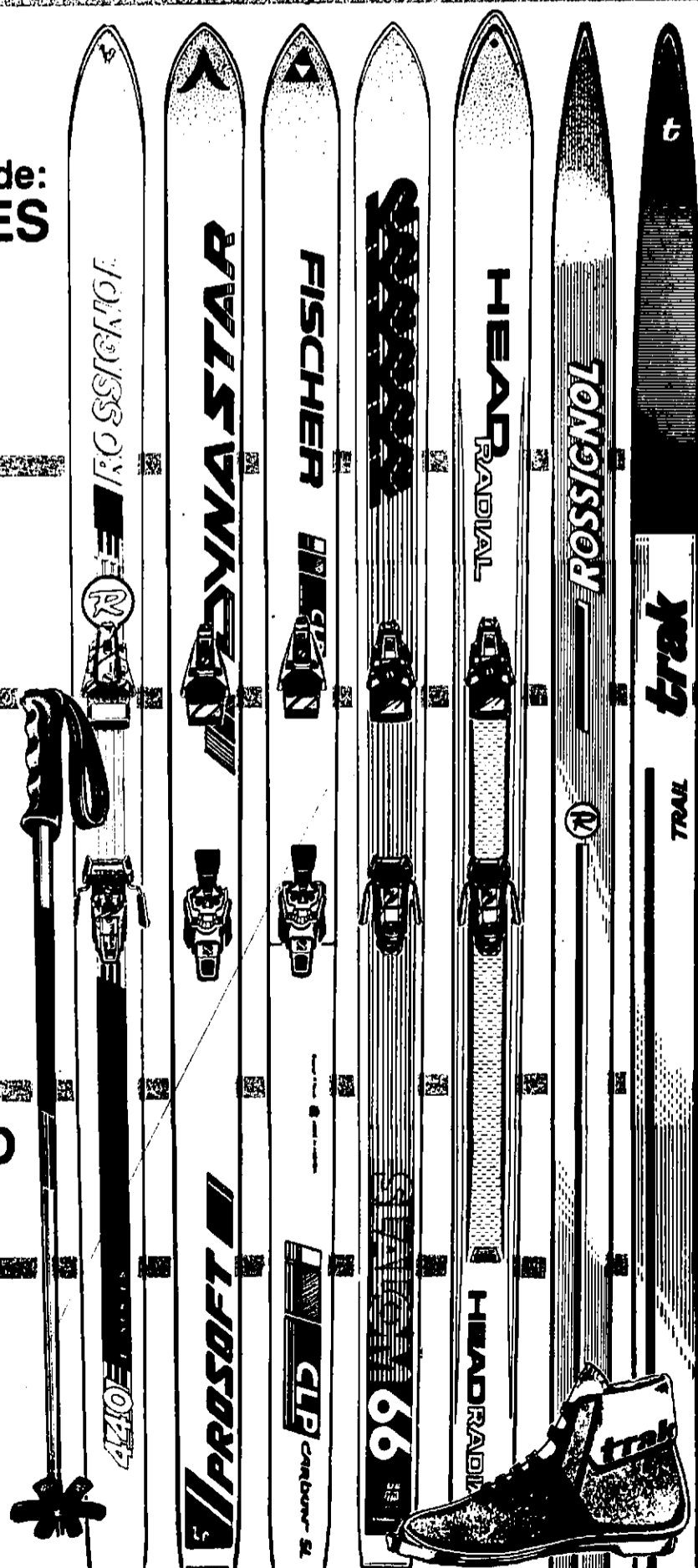

MARATHON SALE

TO 40%

ENTIRE STOCK OF SKI PARKAS, SKI VESTS AND GORE-TEX® SKIWEAR

GERRY, WHITE STAG, PROFILE,
SLALOM, HERMAN'S, ALPINE DESIGNS

**20% TO 25%
OFF**
reg. and orig. prices

EVERY BIB AND STRETCH PANT IN STOCK

WHITE STAG, GERRY, PROFILE, SLALOM and HERMAN'S. Assorted styles,
fabrics and colors for men and women. Coordinate with parkas and sweaters.

EVERY 2-PC. SKI SUIT IN STOCK

Men's and women's styles from SLALOM and PROFILE.
Warm parkas with coordinating bib pants.

EVERY TURTLENECK IN STOCK

PROFILE, and DUOFOLD. Men's and women's styles.
Solid colors. Great values!

ALL SKI GLOVES AND MITTENS

GORDINI, HOTFINGERS, SARANAC,
KOMBI. Men's and women's colors.

ENTIRE STOCK OF SKI UNDERWEAR

DUOFOLD and PROFILE tops and
bottoms for men and women.

ENTIRE STOCK OF SKI SWEATERS

Patterns and solids to
coordinate with parkas and vests.

ENTIRE STOCK OF SKI HATS

Men's and women's fashion
styles. Warm and durable.

ALL CROSS COUNTRY SKIWEAR

Warm, lightweight shells in full zip or pullover
styles. Men's and women's colors.

ALL KIDS' SKIWEAR

• Parkas • Bib Pants • Sweaters • Hats
Coordinating colors. Hurry and save!

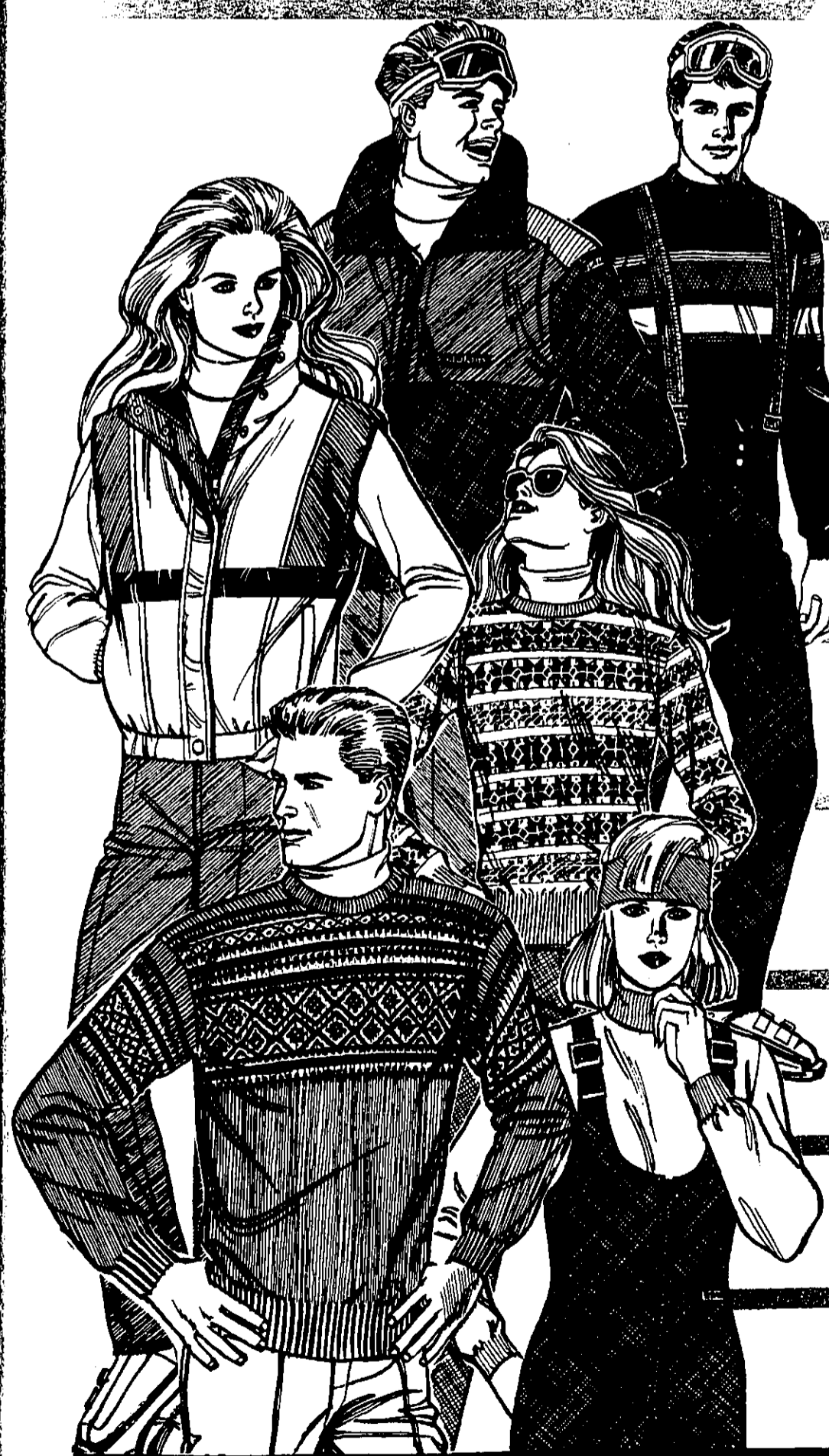

20% OFF WARMUPS

**ADIDAS, REEBOK
PUMA, NIKE
PROFILE, HERMAN'S**
Great collection
at super low
prices!

- PUMA Men's Fashion Fleece Warmup reg. 49.99..... **39.99**
- NIKE Women's Fashion Fleece Warmups reg. 59.99..... **47.99**
- ADIDAS Men's Assorted Warmups reg. 59.99..... **47.99**
- REEBOK Women's Fashion Pullover Warmup reg. 59.99..... **47.99**
- HERMAN'S Men's Warmup (not shown) reg. 39.99..... **27.99**



HERMAN'S New Ultra Sweats II Separates

- Heavier, softer and more durable fabric plus longer length for greater comfort.
- Crew Tops; Pants, reg. 15.99 ea..... **12.79**
- Hooded Tops, reg. 18.99..... **15.19**
- Zip Hood Tops, reg. 22.99..... **18.39**

HERMAN'S Women's Active Fashion Separates

- Short-Sleeve Crew Tops, reg. 8.99..... **7.19**
- Long-Sleeve Crew Tops; Pants, reg. 10.99 ea..... **8.79**
- Stirrup Pants or Oversized Tops, reg. 12.99 ea..... **10.39**
- Hooded Tops, reg. 13.99..... **11.19**
- Zip Hood Tops, reg. 16.99..... **13.59**

a. EVERLAST Men's Separates

- 21.99** tops reg. 27.99
- 19.99** pants reg. 24.99

b. ADIDAS Men's Separates

- 21.99** tops reg. 27.99
- 15.99** pants reg. 19.99

c. ADIDAS Women's Separates

- 23.99** tops reg. 29.99
- 19.99** pants orig. 25.99

d. REEBOK Men's Separates

- 19.99** each, tops or pants reg. 24.99 each

e. REEBOK Women's Separates

- 19.99** tops reg. 24.99
- 15.99** pants reg. 19.99

f. MAIN EVENT Fashion Top

- 16.99** orig. 22.99

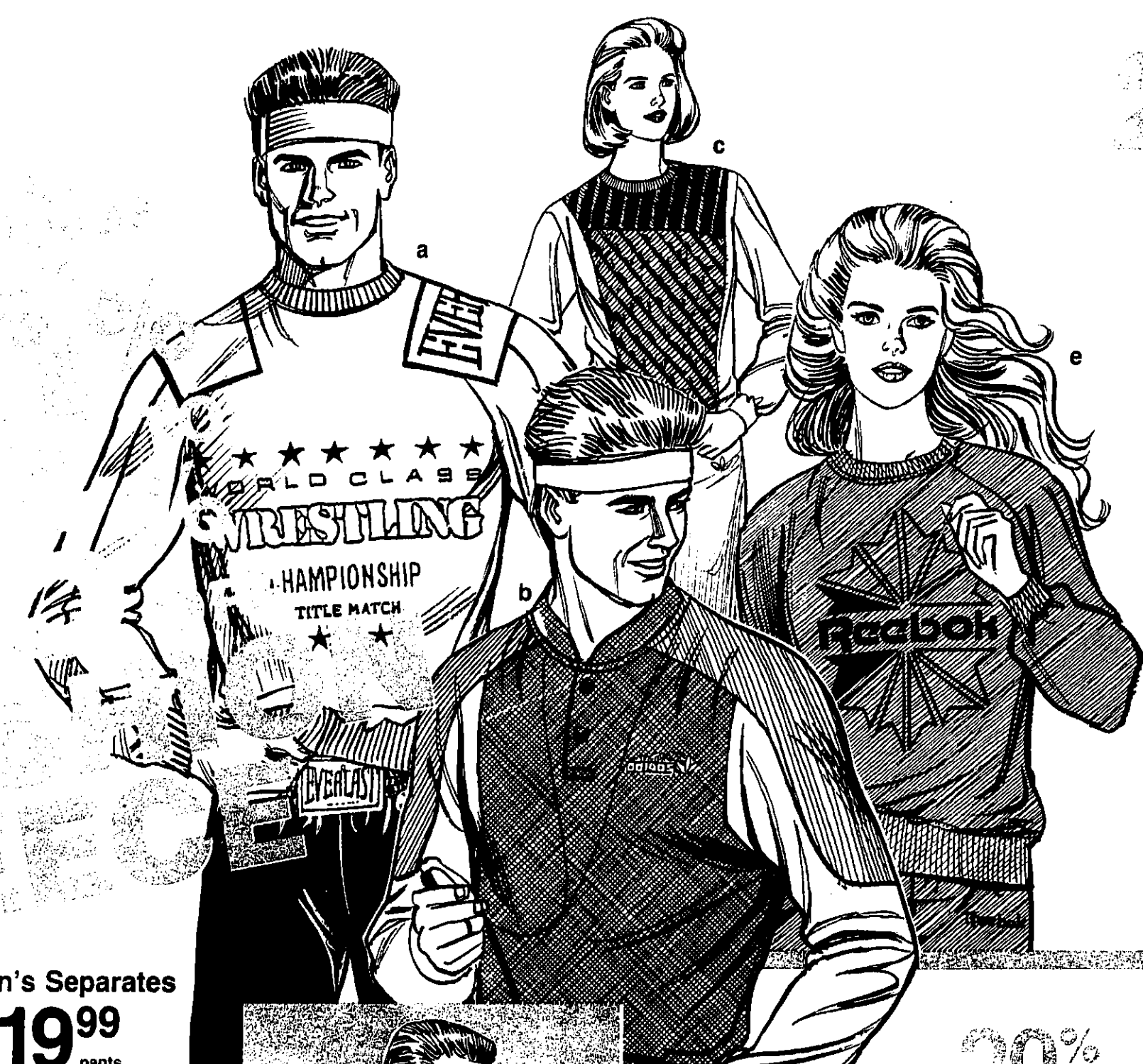

20% OFF
OUR EVERYDAY LOW PRICES ON THE NEWEST STYLES FOR KIDS!

NIKE Fashion Fleece Separates
Assorted styles and colors; accent trims.
15.99 tops reg. 19.99 **14.99** pants reg. 17.99

ADIDAS Fleece Warmup
Cotton blend in great colors.
29.59 reg. 36.99



20% OFF
reg. and orig. prices
Entire Stock of Men's Wind Separates and Running Suits
Lightweight, comfortable nylon.



SAVE BIG NOW ON A WINNING LINE-UP OF FOOTBALL CLOTHING FROM ADIDAS, NIKE, CHAMPION, NIKE and more!

- ADIDAS Men's Plaid Football Jerseys reg. 23.99..... **18.99**
- SPANJIAN Men's Halfback Shorts reg. 13.99..... **11.99**
- NIKE Men's Mesh Jerseys reg. 23.99..... **18.99**
- BIKE Men's Coaches Shorts reg. 15.99..... **13.99**
- CHAMPION NFL Mesh Jerseys reg. 29.99..... **24.99**
- CHAMPION Men's Plaid Football Jerseys, reg. 19.99..... **15.99**
- AJD NFL Corduroy Team Hats reg. 11.99..... **8.99**
- RIDGEVIEW Men's and Boys' 3-pr. Pack Sanitary Socks reg. 4.99 to 5.99..... **3.99 to 4.79**

WORLD OF SPORTING GOODS

ENTIRE STOCK OF BASKETBALLS

reg. prices
Choose from SPALDING, WILSON and MOLTEN. In sizes for men, women and kids!



WILSON Duke Football
Triple lined; grid cord laces; official size and weight.

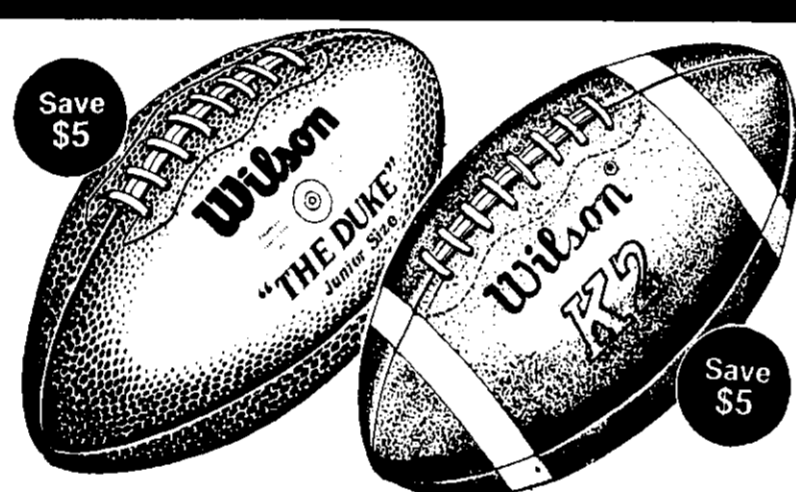
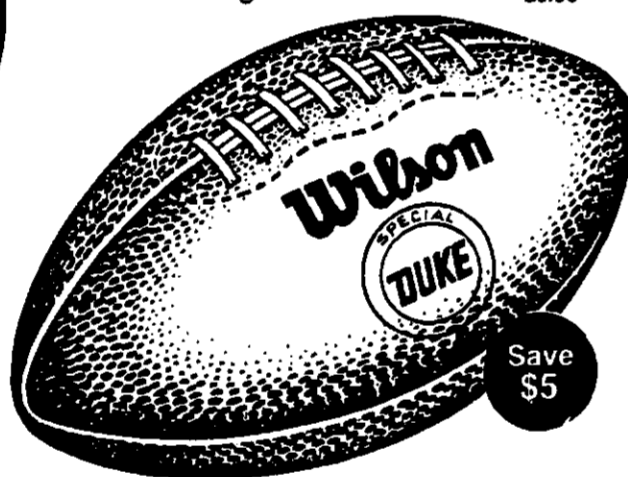

WILSON Duke Jr. or K-2 Peeewe Football
Genuine leather balls sized especially for the younger player.

20% OFF
reg. prices
ALL BOWLING BALLS & BAGS INCLUDING THE FAMOUS AMF ANGLE!

Free measuring, drilling and initialing with ball purchase!

HUSH PUPPIES Men's & Women's Bowling Shoes

24.99
reg. 29.99
Suede & nylon uppers. Padded for comfort.



COLEMAN Camper 3 lb. Sleeping Bag

19.99
final cost
Sale price 24.99. \$5 mailed rebate.

WENZEL Everest Layered 3 lb. Sleeping Bag
Insulated with Holofoil™ II, Nylon shell & lining.

39.99
reg. 49.99

HERMAN'S Experience Cordura® Day Pack
Rugged pack with large pocket and organizer section.

14.99
reg. 19.99

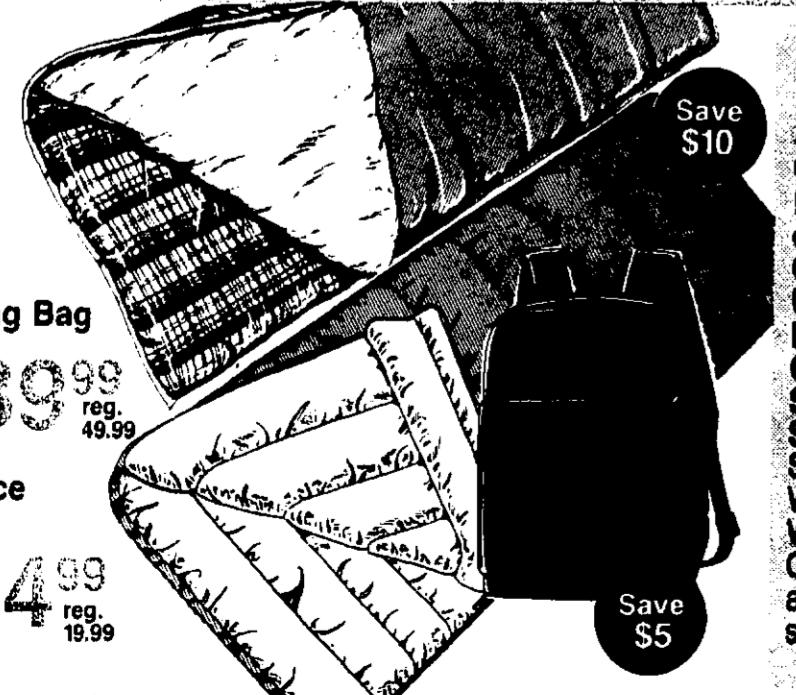

20% OFF
reg. prices
Entire Stock of Hunting Clothing, Underwear, Hats, Socks, Gloves and Snowmobile Suits.
SAF-T-BAK, WOOLRICH, WALLS, more! Choose from assorted styles.



SARANAC Gortex Gloves
24.99
reg. 39.99
Brown camouflage. Thinsulate insulation.

BUSHNELL 7X35 Binocular
27.99
reg. 34.99
Insta-focus with coated optics.

BUSHNELL 10 x 50 Binocular
49.99
reg. 64.99

WILSON Graphite Aggressor Racquetball Racquet
29.99
reg. 39.99
Graphite/glass comp. Cover included.



PRO KENNEX Hogan Comp. Racquetball Racquet
69.99
reg. 79.99
Graphite/glass construction for extra power!

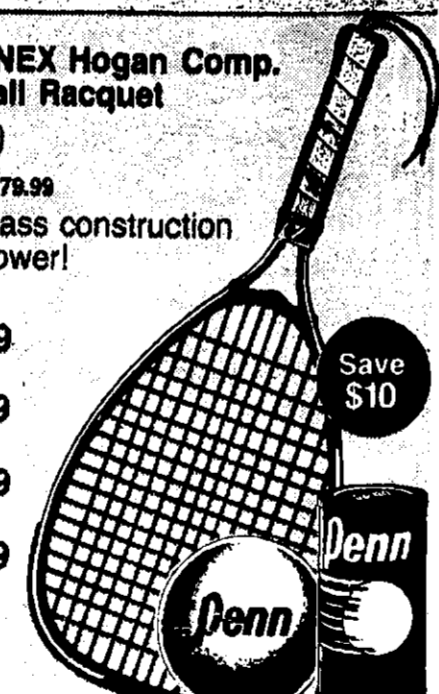

PRO KENNEX Dominator Racquetball Racquet
reg. 29.99.....**24.99**

WILSON Superpower Racquetball Racquet
reg. 15.99.....**12.99**

WYKON® Court Goggles
reg. 16.99.....**13.99**

PENN Racquetballs
reg. 2.99.....**1.99**



SHAPE UP... AND SAVE!

SALE

AMF Benchmark Recumbent Exercise Bike

Offers great back and leg support so you can work out longer and more efficiently. Displays time, resistance and calories burned.

299.99
orig. 699.99



WESTBEND 5100 Power with FREE Scale

Receive a \$35 value fitness scale by mail, in addition to our low sale price!

179.99
orig. 229.99

PRECOR 615E Precision Electronic Rower

Hydraulic tension. Digital readout of time, stroke rate, total strokes.

299.99
reg. 349.99



NFI Aerobic Climber

Offers quick and efficient cardiovascular workout. Strengthens feet, legs and waist.

99.99
reg. 119.99

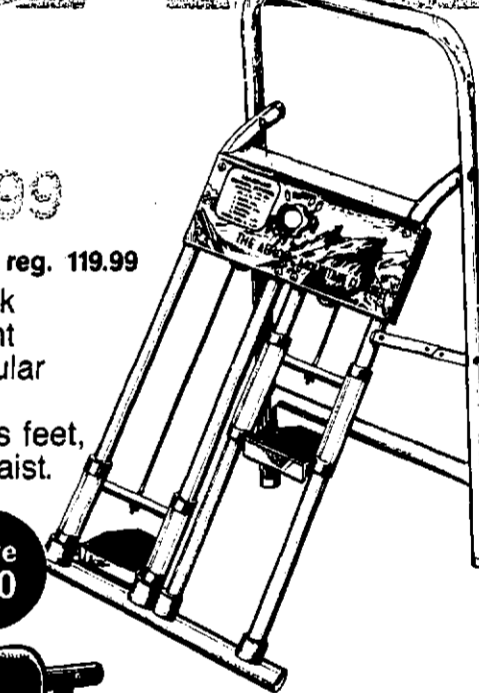

Total Gym® Fitness System by WESTBEND with FREE SCALE!

289.99
orig. 389.99
Designed to utilize your body weight as resistance. Unit allows performance of over 70 exercises. Receive a \$35 value fitness scale by mail!



MCA Flywheel Exercise Bike
Speedometer, odometer & timer. Adjustable tension.

99.99
reg. 129.99

AMF VOIT Ergometer Exercise Bike
Measures your energy output. Great buy!

159.99
orig. 249.99

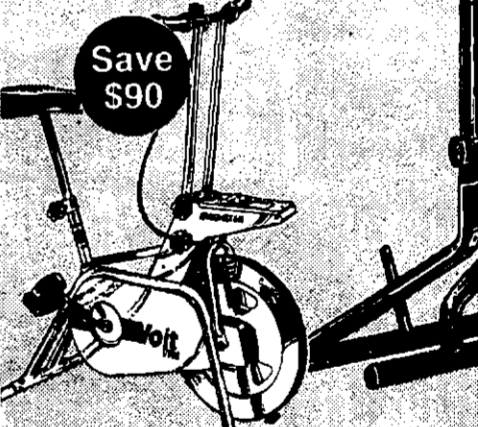

FBM Stomach/Back Machine

Trims, flattens stomach; develops upper body while strengthening back muscles, too.

119.99
orig. 159.99



20% OFF
reg. prices
ENTIRE STOCK OF WEIGHT BENCHES, SLANTBOARDS & LOOSE WEIGHTS

BILLARD 110 lb. Iron Weight Set.....**49.99**
reg. 69.99
TRIANGLE 70 lb. Softweight Set.....**49.99**
orig. 119.99
WEIDER 160 lb. Weight Set.....**99.99**
reg. 139.99

EVERLAST 70 lb. Canvas Heavy Bag.....**49.99**
reg. 69.99
40" Aerobic Jogger.....**27.99**
orig. 39.99
MARCY Weightlifting Gloves.....**9.99**
reg. 12.99
KR INDUSTRIES 2X6 Exercise Mat.....**9.99**
reg. 13.99
TRIANGLE Band Wrist/Ankle Weights
reg. 14.99 to 21.99.....**12.99 to 18.99**
TRIANGLE Softbell Dumbbell Sets
• 6 lb. pr., reg. 17.99.....**14.99**
• 12 lb. pr., reg. 21.99.....**17.99**

MARCY EM-1 Deluxe Home Fitness System

499.99
reg. 549.99
Comes with 200 lbs. of weight capacity which can be increased up to 320 lbs. (extra cost)
Freestander reg. 169.99...**139.99**
Butterfly Unit reg. 219.99...**159.99**

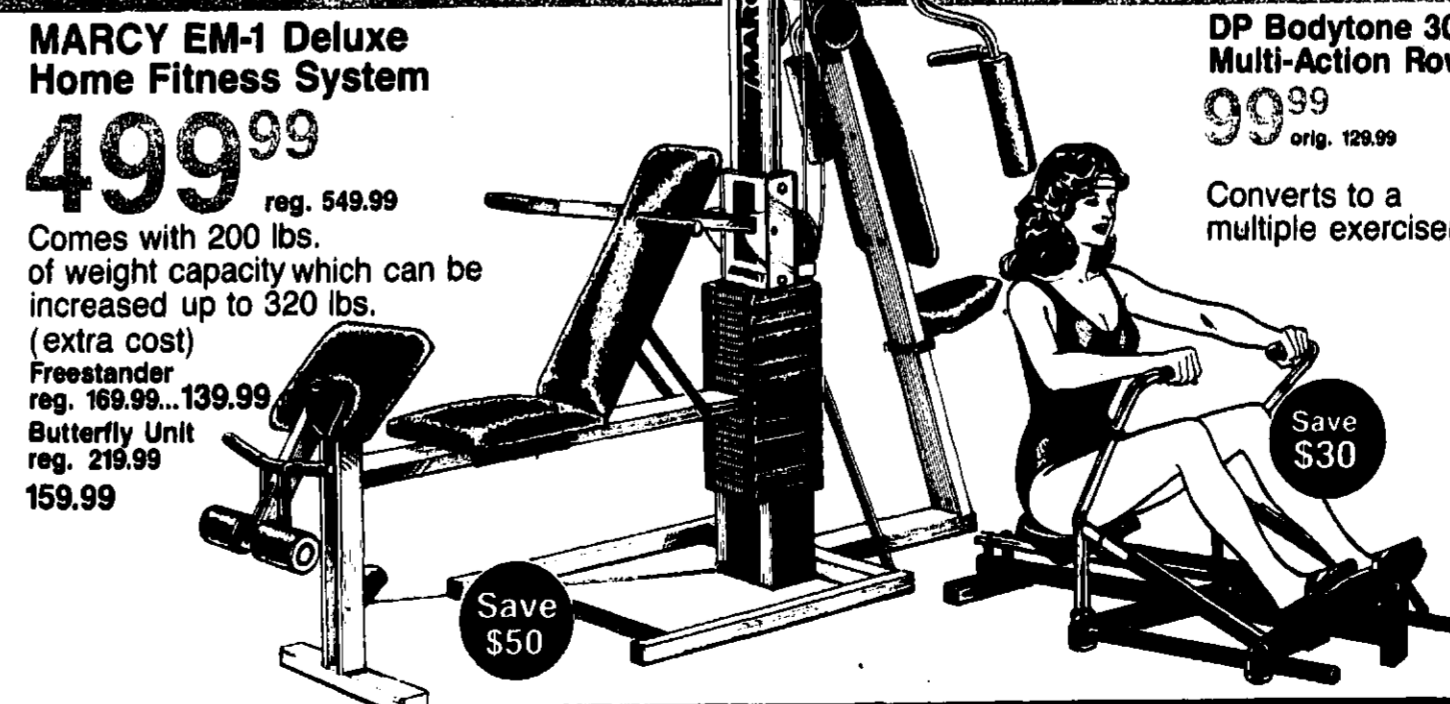

DP Bodytone 300 Multi-Action Rower
99.99
orig. 129.99
Converts to a multiple exerciser.



Herman's
WORLD OF SPORTING GOODS

we are sports

SALE

BASKETBALL

Fantastic Value!
ADIDAS Decade
Men's High Tops
34⁹⁹ orig. 59.99
Leather uppers;
traction sole.
SAVE \$25



Save \$7
CONVERSE
Men's Spectre
24⁹⁹ 26⁹⁹
Low Top reg. 31.99 High Top reg. 34.99

Save \$8
NIKE Men's
Convention
36⁹⁹
reg. 44.99
Leather high tops;
durable sole.

Save \$6
REEBOK
Men's 4600
39⁹⁹
reg. 45.99
Ankle-supportive
leather high tops.

Save \$10
CONVERSE
Men's Weapon
49⁹⁹
reg. 59.99
As worn by Larry
Bird and "Magic".

Save \$10
REEBOK
Men's 6600
55⁹⁹
reg. 65.99
No-break-in
garment leather.

TENNIS



Save \$5
HEAD Edge
for men
34⁹⁹
reg. 39.99
Leather uppers;
hobnail sole.



Save \$9
REEBOK Leather
Phase I
39⁹⁹
reg. 48.99
Heel stabilizer;
men's and women's.



Save \$7
REEBOK Men's
ACT 600
52⁹⁹
reg. 59.99
Soft leather.
Women's ACT 600,
reg. 56.99.....49.99



Save \$10
REEBOK Women's
Freestyle Low
32⁹⁹
reg. 42.99
Garment leather;
cushioning wedge.



Save \$7
NIKE Rake
for men
42⁹⁹
reg. 49.99
Soft leather;
molded midsole.



Save \$7
REEBOK Men's
Workout Mid
47⁹⁹
reg. 54.99
Leather uppers;
support straps.

KIDS



Save \$5
REEBOK CLT-50
Tennis Shoes
27⁹⁹
reg. 32.99
Durable soft leather;
rugged rubber sole.



Save \$5
REEBOK High Top
Basketball Shoes
34⁹⁹
reg. 39.99
All leather; great
support at ankles.

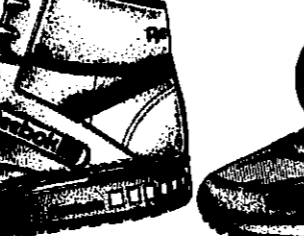

Save \$5
NIKE Windrunner
for men and women
34⁹⁹
reg. 39.99
Variable lacing; Nike
Air-Liner® cuts shock.



Save \$7
SAUCONY
Freedom GT
42⁹⁹
reg. 49.99
Men's and women's;
nylon/suede uppers.



Save \$10
NIKE Venue
for men
49⁹⁹
reg. 59.99
Nike Air-Wedge®
helps reduce shock.

WORKOUT

20% OFF Marked prices
All NIKE, ADIDAS,
REEBOK Socks



SOCKSMITH
Men's & Boys'
6-pr. Pack
Sport Socks **6⁹⁹**
reg. 8.99



LeSOK
Women's
6-pr. Pack
Crew Socks **7⁹⁹**
reg. 9.99



- BIRMINGHAM: 13 Mile & Southfield Rds.
- TROY: 288 John R. Road
- SOUTHFIELD: Northland Shopping Center
- HARPER WOODS: Eastland Center
- STERLING HEIGHTS: Lakeside Mall

- FLINT: Genesee Valley Mall
- DEARBORN: Fairlane Town Center
- NOVI: Twelve Oaks Mall
- LANSING: Lansing Mall
- ANN ARBOR: Briarwood Mall

• Toledo Ohio: Talmadge Plaza

VISIT OUR 2 NEW STORES:
WESTLAND
Across from Westland Mall
SOUTHGATE
Eureka Rd. & Dix Toledo Rd.

NOTE: All items may not be available at all stores. Savings reflect reductions off regular and/or original prices. Intermediate mark-downs may have been taken.

Ethan Allen

SPECIAL GIFTS AT SPECIAL SAVINGS



SALE BEGINS NOVEMBER 7, 1986 • SALE ENDS DECEMBER 25, 1986

Georgetown Manor

Member of Interior Design Society
LIVONIA UTICA

15700 Middlebelt Rd. 50170 Van Dyke
Between 5 & 6 Mile Rds. Between 22 & 23 Mile Rds.
261-7780 254-5260

Open Mon./Thurs./Fri. til 9 • Tues./Wed./Sat. til 5:30 • Sunday 1 til 5 2268-2



Experience the difference in holiday shopping

When searching for that special holiday gift, you'll find there is a difference at Ethan Allen.

EXPERIENCE ETHAN ALLEN'S QUALITY. With an impressive gift from Ethan Allen, comes the prestige of giving the very best. A tradition that stands behind superior craftsmanship and value in real savings.

EXPERIENCE ETHAN ALLEN'S CONVENIENCE. An extensive selection of unique gifts, in a wide range of prices, all in one place! Saving time... making shopping easy.

EXPERIENCE ETHAN ALLEN'S PERSONAL SERVICE. Our professional interior designers will help you make the perfect choice — from selecting a miniature vase to re-doing a room. A helpful service that's yours... free!

We invite you to come in. Experience the Ethan Allen difference. You'll be glad you did!



OUR EXCLUSIVE 1986 CHRISTMAS PLATE. Truly a collector's classic! Skillfully hand made by talented American craftsmen, each a unique gift destined to bring holiday cheer to someone special on your list. The 15" diameter, molded glass plate is sixth in our series designed for Ethan Allen exclusively. Quantities are limited, so hurry. 43 6526 Holiday special \$10.75

ONE GIFT THAT'S ALWAYS WELCOME! You know where... Ethan Allen. But if you don't know what, let them make their own choice... with an Ethan Allen gift certificate in any amount. Even if they have everything, it's the one gift they'll always appreciate! (Was your holiday shopping ever easier?)

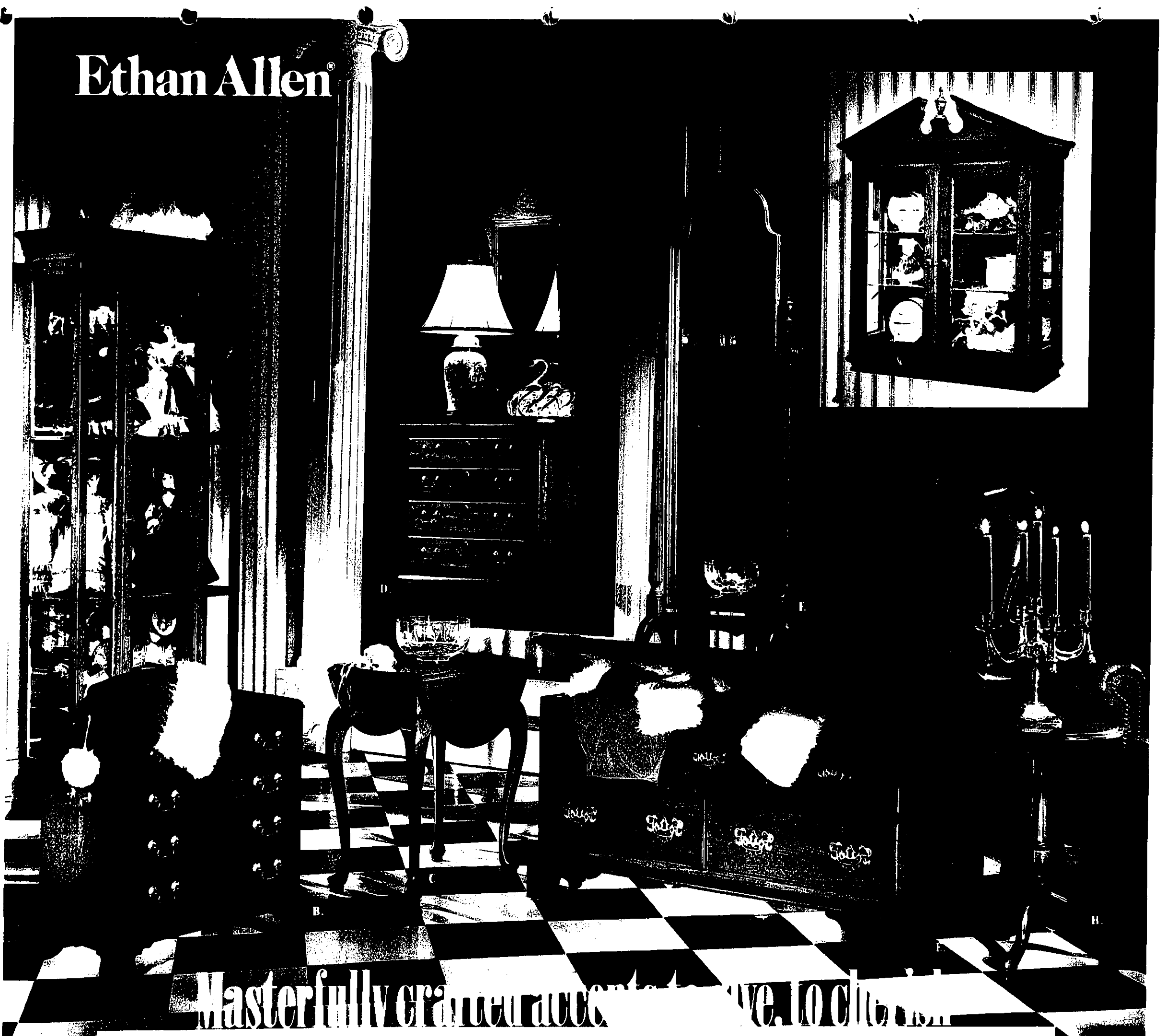

Masterfully crafted accents... we're looking for you.

- A. SAVE \$150.00 ON CURIO CABINET.** Clean, classic lines make this a fine showcase for your favorite things. Collectibles are highlighted by mirrored back and dramatic lighting. Four adjustable glass shelves. 32"W x 13"D x 72"H. 11-9019. Reg. \$1029.75... Sale \$879.75
- B. SAVE \$60.00 ON CHAIRSIDE CHEST.** A great companion for your favorite chair. 22"W x 13"D x 22"H. 11-9023. Reg. \$439.75... Sale \$379.75
- C. SAVE \$50.00 ON DROP LEAF END TABLE.** Truly an investment in 18th century grace and elegance. Opens to 26" with leaves up. 14"W x 20"D x 23"H. 11-8013. Reg. \$309.75... Sale \$259.75
- D. SAVE \$145.00 ON CHEST & MIRROR.** Add function and beauty to entrance or living room. BACHELOR'S CHEST, 32"W x 17"D x 31"H, 11-9209. Reg. \$699.75... Sale \$559.75
CHIPPENDALE MIRROR, 20"W x 38 1/2"H, 11-9202. Reg. \$224.75... Sale \$189.75
*CHEST & MIRROR SET. Reg. \$924.50... Sale \$779.50
- E. SAVE \$100.00 ON OUR BLANKET CHEST.** Stores your favorite blankets, towels, linens, sweaters, more. Lined in fragrant cedar. 44"W x 18"D x 21"H. 11-5117. Reg. \$599.75... Sale \$499.75
- F. SAVE \$60.00 ON CHEVAL FLOOR MIRROR.** 18th century styling that tilts for the perfect view... from head to toe. 64"H. 11-5250. Reg. \$409.75... Sale \$349.75
- G. SAVE \$50.00 ON WALL CURIO CABINET.** Two adjustable shelves; mirrored back. 22"W x 8"D x 27"H. 11-3032. Reg. \$369.75... Sale \$319.75
- H. GRACEFUL QUEEN ANNE WINE STAND.** Use chairside or as an accent. 15"D x 21"H. 11-8008. Reg. \$99.75... Sale \$84.75
Manufacturer's suggested resale prices, optional with retailer.

Superb quality lighting...styles for every room

A variety in style and design. That's the Ethan Allen difference. Hundreds of lamps from which to choose...each with the beauty, quality and value you expect from Ethan Allen. Chandeliers, table and floor lamps in glimmering brass, elegant porcelain and classic stoneware, all capturing a holiday glow.

- A. SAVE \$40.00 ON BRASS PHARMACY LAMP.**
Adjusts from 36" to 51" 09-2106. Reg. \$209.75. Sale \$169.75
- B. SAVE \$70.00 ON SIX-LIGHT BRASS CHANDELLER.**
Imported from Italy. 22"W x 22"H. 09-3201. Reg. \$449.75. Sale \$379.75
- SAVE \$10.00-\$50.00 ON OUR LEAD CRYSTAL LAMPS.**
Hand-cut multi-faceted designs from Europe.
- C. MINI ACCENT LAMP 16"H. 09-4551. Reg. \$79.75. Sale \$69.75**
- D. VASE LAMP 27"H. 09-4549. Reg. \$249.75. Sale \$199.75**
- SAVE \$40.00-\$50.00 ON BOULLOTTE DESK LAMPS.**
Each heralds distinction and classic styling.
- E. CAST BRASS HORN STYLE. 21"H. 09-4545. Reg. \$249.75. Sale \$199.75**
- F. BURNISHED BRONZE FINISH STYLE. 26"H. 09-4161. Reg. \$219.75. Sale \$179.75**
- G. SAVE \$20.00-\$50.00 ON GLEAMING TABLE LAMPS.**
(Shown left to right):
FUNCTIONAL SOLID BRASS DESK LAMP: frosted glass shade. 16"H. 09-4452. Reg. \$119.75. Sale \$99.75
CAST METAL GINGER JAR LAMP with polished brass finish. 23"H. 09-4430. Reg. \$179.75. Sale \$149.75
SOLID BRASS VASE LAMP: hand-engraved design. 29"H. 09-4520. Reg. \$249.75. Sale \$199.75
RIBBED URN LAMP with polished bronze finish. 27"H. 09-4481. Reg. \$149.75. Sale \$119.75
COLONIAL STYLE OIL LAMP: polished brass finish. 20"H. 09-4457. Reg. \$79.75. Sale \$69.75
- H. SAVE \$20.00 ON BRASS FINISH WALL SWINGER.**
13"H. 09-3245. Reg. \$189.75. Sale \$169.75
- J. SAVE \$30.00 ON OUR CERAMIC TEMPLE JAR LAMP.**
With crackle glaze finish. Brass finish base. 30"H. 09-4407. Reg. \$129.75. Sale \$99.75
- K. SAVE \$40.00 ON PORCELAIN VASE LAMP.**
Graceful hand-decorated Oriental design. 27"H. 09-4547. Reg. \$269.75. Sale \$229.75
- L. SAVE \$30.00 ON HAND-PAINTED CERAMIC JAR LAMP.**
25"H. 09-4557. Reg. \$129.75. Sale \$99.75
- M. SAVE \$50.00 ON OUR IMPORTED CERAMIC LAMP.**
With raised leaf design. 29"H. 09-4573. Reg. \$229.75. Sale \$199.75
- N. SAVE \$40.00 ON OUR IMPORTED PORCELAIN JAR LAMP.**
Embellished with 23K gold trim. 27"H. 09-4550. Reg. \$249.75. Sale \$219.75



Ethan

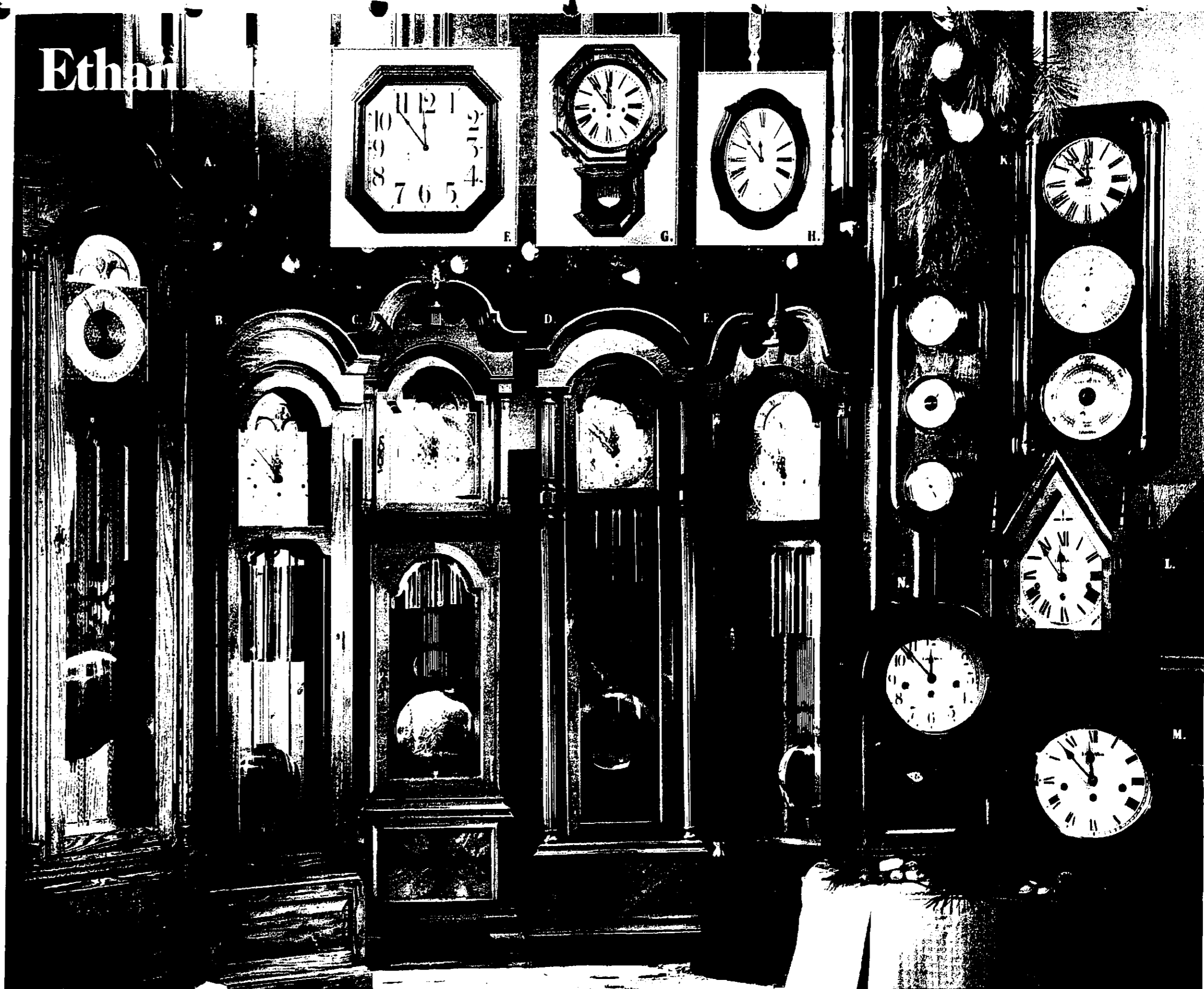

Stately clocks today...heirlooms tomorrow

Enduring quality. The Ethan Allen difference. In a selection of well-designed clocks and weather stations. Renowned for a tradition of fine craftsmanship, each is expressed in specially selected cabinet woods, hand-rubbed for a warm finish... timeless beauty.

SAVE \$200.00-\$700.00 ON FLOOR CLOCKS.

Exclusively constructed, each has large solid brass pendulum and richly detailed, etched face. Accurate West German movements; triple chime selection.

- A. CORNWALL OAK FLOOR CLOCK. 77"H. 41-3044. Reg. \$1199.75. Sale \$999.75**
- B. CANTERBURY PINE FLOOR CLOCK. 78 1/2"H. 41-3051. Reg. \$1299.75. Sale \$1099.75**
- C. GREENWICH MAHOGANY FLOOR CLOCK. 88"H. 41-3048. Reg. \$2999.75. Sale \$2299.75**

- D. ESSEX MAHOGANY FLOOR CLOCK. 82"H. 41-3045. Reg. \$1799.75. Sale \$1499.75**
- E. WESTPORT CHERRY FLOOR CLOCK. 80"H. 41-3043. Reg. \$1329.75. Sale \$1099.75**

- ETHAN ALLEN WALL CLOCKS.**
- F. FAIRFIELD QUARTZ CLOCK: Oak finish. 22 1/2"W x 22 1/2"H. 41-2027. Reg. \$179.75. Sale \$149.75**
- G. COS COB KEYWIND SCHOOLHOUSE CLOCK in solid Pine with nutmeg finish. 12 1/2"W x 20"H. 41-2020. Reg. \$299.75. Sale \$249.75**
- H. LITCHFIELD GALLERY WALL CLOCK with precise quartz movement. Cherry finish. 12"W x 17"H. 41-2025. Reg. \$129.75. Sale \$99.75**

- HANDSOME WEATHER STATIONS.**
- J. THIS GUILFORD WEATHER STATION includes a thermometer, barometer and hygrometer. In solid Cherry. 7"W x 18 1/4"H. 41-1715. Reg. \$79.75. Sale \$64.75**

- K. NIANTIC CLOCK/WEATHER STATION with a battery-operated quartz clock, barometer and thermometer. Cherry finish. 10 1/4"W x 25"H. 41-1719. Reg. \$139.75. Sale \$119.75**

- SAVE \$50.00 ON MANTEL CLOCKS.**
- L. HAMDEN COLONIAL STEEPLE CLOCK with keywind movement and Westminster chimes. In solid Pine. 10"W x 20"H. 41-4035. Reg. \$299.75. Sale \$249.75**
- M. WALLINGFORD TAMBOUR CLOCK in solid Cherry with olive ash burl overlays. Westminster chimes. 18"W x 11"H. 41-4035. Reg. \$349.75. Sale \$299.75**

- N. OUR MERIDEN COTTAGE MANTEL CLOCK in Pine has keywind movement and plays Westminster chimes. 11"W x 17"H. 41-4034. Reg. \$299.75. Sale \$249.75**
- Manufacturer's suggested resale prices, optional with retailer.

Comfort and value...the Ethan Allen difference

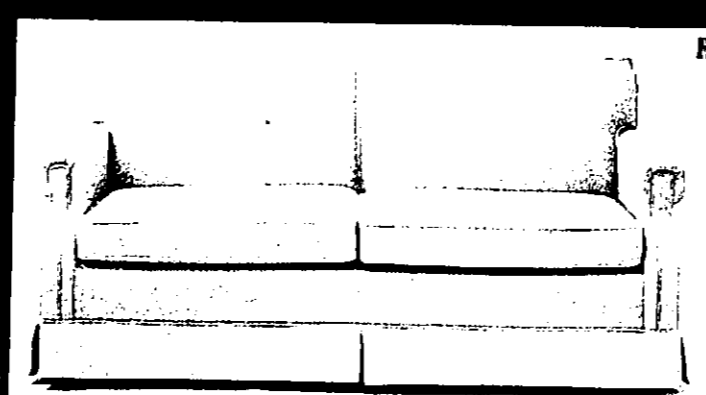
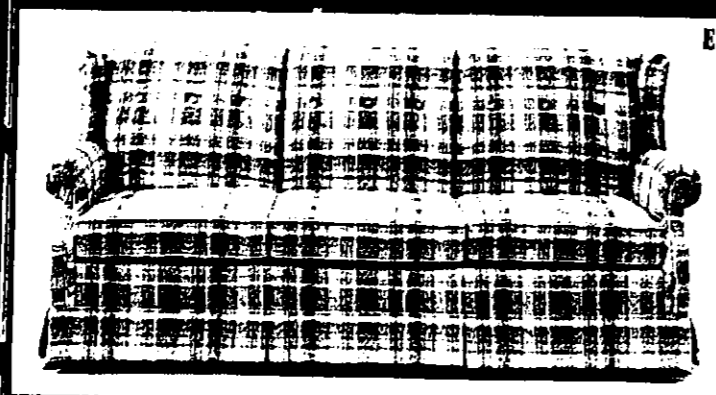
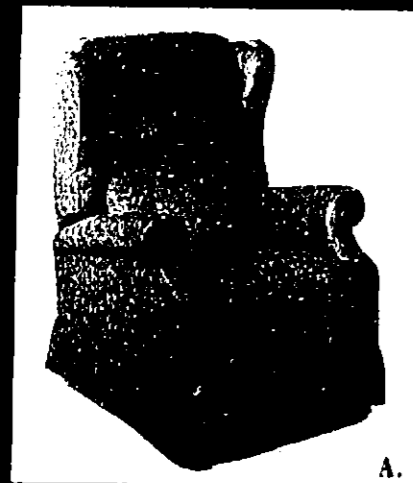

Discover the difference in our top quality sleeper sofas and Restocrat™ recliners. Each sleeper sofa has a luxurious innerspring mattress and adjustable headrest for TV or reading. Each recliner has a concealed reclining mechanism that responds easily to your favorite lounging position. Both covered in a selection of beautiful, durable fabrics.

A. SAVE \$65.00 ON INVITING ROCKER RECLINER.
Adjusts for sitting or lounging. In 100% cotton. 40"H. 21-7910.
Reg. \$524.50 Sale \$459.50

B. SAVE \$75.00 ON OUR RELAXING ROCKER RECLINER.
Solid Maple arms. Numeq finish. In durable olefin/polyester.
38"H. 21-7911.
Reg. \$624.50 Sale \$549.50

C. SAVE \$72.00 ON QUEEN ANNE RECLINER.
Elegant, tailored and available in rayon/cotton. 44"H. 21-7967.
Reg. \$691.50 Sale \$619.50

D. SAVE \$64.00 ON ROLL-ARM RECLINER.
Available in 100% Herculon® olefin. 39"H. 21-7953.
Reg. \$563.50 Sale \$499.50

E. SAVE \$125.00 ON ROLL-ARM WING SLEEP SOFA.
Queen size. In Herculon® olefin. 78"L. Also available in full and twin sizes at comparable savings. 21-7014.
Reg. \$1054.50 Sale \$919.50

F. SAVE \$150.00 ON LAWSON STYLE SLEEP SOFA.
Full size. In Herculon® olefin. 71"L. Also available in queen and twin sizes at comparable savings. 21-7053.
Reg. \$849.50 Sale \$699.50

G. SAVE \$144.00 ON OUR TUXEDO SLEEP SOFA.
Full size. In a durable nylon blend. 72"L. Also available in queen and twin sizes at comparable savings. 21-7043.
Reg. \$1044.50 Sale \$899.50

Exact dimensions of upholstered furniture may vary slightly depending on type of fabric.
Manufacturer's suggested resale prices, optional with retailer.



Our best-selling sofas represent Ethan Allen's excellence in quality and style that will endure through the years. In a selection of our most popular fabrics!

A. SAVE \$239.50 ON LEATHER UPHOLSTERY.*
Soft and supple, there's nothing quite like our rich, genuine top-grain leather chairs for comfort and good looks that improve with age. In tortoise brown and saddle.
LOUNGE CHAIR. 20-7236. Sale \$969.50
Reg. \$1119.50
MATCHING OTTOMAN. 20-7237. Sale \$369.50
Reg. \$419.50
*CHAIR AND OTTOMAN SET (2 pcs. shown).
Reg. \$1539.00 Sale \$1299.50

B. SAVE \$430.50 ON STRAIGHT ARM SOFA.** Loose pillow back. 82"L. 20-7803. Reg. \$1239.50 Sale \$799.00
C. SAVE \$430.50 ON OUR ROLL ARM SOFA.** Loose pillow back. 84"L. 20-7003. Reg. \$1329.50 Sale \$899.00
D. SAVE \$80.00 ON SLEEK BRASS & GLASS END TABLE that adds a touch of elegance. 22" x 27" x 22"H. 13-8225. Reg. \$529.75 Sale \$449.75
E. SAVE \$285.50 ON TIGHT BACK ROLL ARM SOFA.** 82"L. 20-7493. Reg. \$1284.50 Sale \$999.00
F. SAVE \$100.00 ON BRASS & GLASS COCKTAIL TABLE. Adds sparkle to your room setting. 38" x 38" x 17"H. 13-8221. Reg. \$729.75 Sale \$629.75
G. UPHOLSTERED CANE OCCASIONAL CHAIR, assumes a comfortable position in your decor. 13-7805-5. Reg. (As Shown) \$549.50 Sale \$509.50
Reg. (Starting fabric) \$489.50 Sale \$449.50

While every effort has been made to anticipate reasonable demands, we regret that we cannot assure that every item in this book is in stock. Every effort has been made to insure the accuracy of prices and dimensions. However, we regret that we cannot accept responsibility for typographical errors.
All suggested prices in this book are in effect through December 24, 1986.
**Also available as loveseat or full and queen size compatible sleeper sofas at comparable savings.

Ethan Allen

Timeless designs...quality craftsmanship...personal service...only at Ethan Allen

The Ethan Allen difference. Each timeless design combines superb craftsmanship with the luster of a hand-rubbed finish. To enrich your home year after year, as only Ethan Allen can. Of course, Ethan Allen's design service can put it all together — from elegant French country styling to casual looks.

- A. HAND-DECORATED ROCKERS.** Charming Boston rockers in white or black. Intricate foliage stenciling.
- BOSTON ROCKER, 41"H, 14-9703, Reg. \$249.75, Sale \$209.75
CHILD'S ROCKER, 29"H, 14-9705, Reg. \$164.75, Sale \$139.75
- B. CUSHIONY ROCKER SETS.** In fine pinwale cotton/polyester corduroy; plump foam fill. Red, gold, brown, copper, flag, natural, 06-875C-1.
- Reg. \$50.00, Sale \$42.50
- C. SAVE \$100.00 ON PINE CONSOLE & MIRROR.*** Destined to become the center of attraction in your room.
- CONSOLE, 27"W x 15"D x 34"H, 19-9302, Reg. \$339.75, Sale \$289.75
MIRROR, 24"W x 44"H, 19-9301, Reg. \$159.75, Sale \$134.75
*CONSOLE & MIRROR SET, Reg. \$499.50, Sale \$399.50
- D. COUNTRY FRENCH WALL SHELF.** Three spacious shelves for displaying knick-knacks. In warm, inviting Birch, 18"W x 7"D x 26"H, 26-3002, Reg. \$189.75, Sale \$159.75
- E. PINE GALLERY SHELVES.** Display all your treasured collectibles, from books to plants!
- 18"L, 19-3558, Reg. \$34.75, Sale \$29.75
24"L, 19-3559, Reg. \$47.75, Sale \$32.75
30"L, 19-3560, Reg. \$49.75, Sale \$34.75
- F. APOTHECARY WALL CABINET.** Provides handsome storage in Country Craftsman Pine. Four handy drawers, 20 1/2"H, 19-3308, Reg. \$134.75, Sale \$114.75
- G. SAVE \$50.00 ON CLASSIC BARNSTABLE ROCKER.** Deep saddle seat, 45"H, 12-9720, Reg. \$349.75, Sale \$299.75
- SPACE-SAVING FURNISHINGS!** From our Country Craftsman Collection.
- H. SNACK TABLE SET.** Four folding tables, plus a convenient storage stand. Each table measures 16"W x 21"D x 24"H, 19-3500, Reg. \$309.75, Sale \$259.75
- J. COUNTRY STYLE POT RACK.** Six hooks hold pots and pans. One shelf, 29"W x 7"D x 10"H, 19-3003, Reg. \$92.75, Sale \$74.75
- K. SAVE \$150.00 ON COUNTRY FRENCH MIRROR & CONSOLE,*** reflecting the romantic designs of the French Provincial period.
- CONSOLE, 48"W x 14"D x 27"H, 26-9302, Reg. \$469.75, Sale \$399.75
MIRROR, 22"W x 44"H, 26-9300, Reg. \$329.75, Sale \$279.75
*CONSOLE & MIRROR SET, Reg. \$799.50, Sale \$649.50
- L. DRESSING VALET** has enough space for coat, slacks, shoes, even jewelry! In Pine and Maple, 18"W x 44"H, 19-3510, Reg. \$124.75, Sale \$99.75
- M. OUR DECORATIVE QUILT RACK** puts your best quilt, blanket or comforter on display, 26"W x 30"H, 19-3009, Reg. \$139.75, Sale \$119.75
- N. BOWBACK WINDSOR ROCKER.** From our Circa 1776 Maple Collection, 40"H, 18-9710, Reg. \$231.75, Sale \$199.75
- P. SAVE \$50.00 ON 10-LIGHT WILLIAMSBURG CHANDELIER.** Double tier style in glowing solid brass, 22"H, 09-5249, Reg. \$369.75, Sale \$319.75
- Q. HAND-DECORATED SALT GLAZE CERAMIC LAMP.** 28"H, 09-4539, Reg. \$199.75, Sale \$169.75
- R. HANDSOME PAIR OF HORSES** guards your literary treasures. Solid brass on a cherry finish; felted base. Imported from England. Pr., each 6"H, 42-1963, Reg. \$89.75, Sale \$74.75
- S. SAVE \$80.00 ON MAPLE DEACON'S BENCH.** Perfect for those who love traditional designs, 54"W x 38"H, 18-6805, Reg. \$509.75, Sale \$429.75
- T. COUNTRY CRAFTSMAN SHAKER CANDLESTAND.** Holds more than just a candle. In Pine and Maple, 16"D x 24"H, 19-8310, Reg. \$94.75, Sale \$79.75
- U. SAVE \$50.00 ON AUTHENTICALLY DESIGNED DESK.** In Country Craftsman Pine; one spacious drawer, 40"W x 22"D x 37"H, 19-9303, Reg. \$309.75, Sale \$259.75
- V. SPINDLE MAGAZINE RACK IN ENDURING PINE.** Keeps magazines and newspapers neatly at reach, beside your favorite chair, 16"W x 10"D x 19"H, 19-3509, Reg. \$99.75, Sale \$84.75
- W. SAVE \$150.00 ON COUNTRY FRENCH CURIO CABINET.** Displays your very finest. Mirrored with lighted interior. Antiqued glass doors. In Birch, 35"W x 12 1/4"D x 76"H, 26-9303, Reg. \$979.75, Sale \$829.75
- Manufacturer's suggested resale prices, optional with retailer.



SPECIAL VALUE!

SAVE \$370.00 ON CLASSIC ROLL TOP DESK AND CHAIR
Masterfully crafted in Pine, portraying our great American heritage.
ROLL TOP DESK, 55 1/2 x 48 1/2 H, 12-9519, Reg. \$1,289.75, Sale \$1,019.75
SWIVEL CAPTAIN'S CHAIR, 31 H, 12-9530, Reg. \$379.75, Sale \$299.75
DESK & CHAIR SET, Reg. \$1,669.50, Sale \$1,299.50

Ethan Allen

SPECIAL VALUES!



SAVE \$85 ON PINE TV/VCR CART.
Accommodates your video equipment in style. Can also be used as a stereo stand. Hidden easy-roll castors. 34" W x 17 1/2" D x 26 1/2" H. 12-9018. Reg. \$234.75 Sale \$149.75



SAVE \$80 ON PINE STEREO STAND.
Stores all your stereo equipment and complements your decor, too! With storage partitions for records and tapes. Four shelves. Hidden easy-roll castors. 24" W x 17" D x 45 1/2" H. 12-9045. Reg. \$349.75 Sale \$269.75

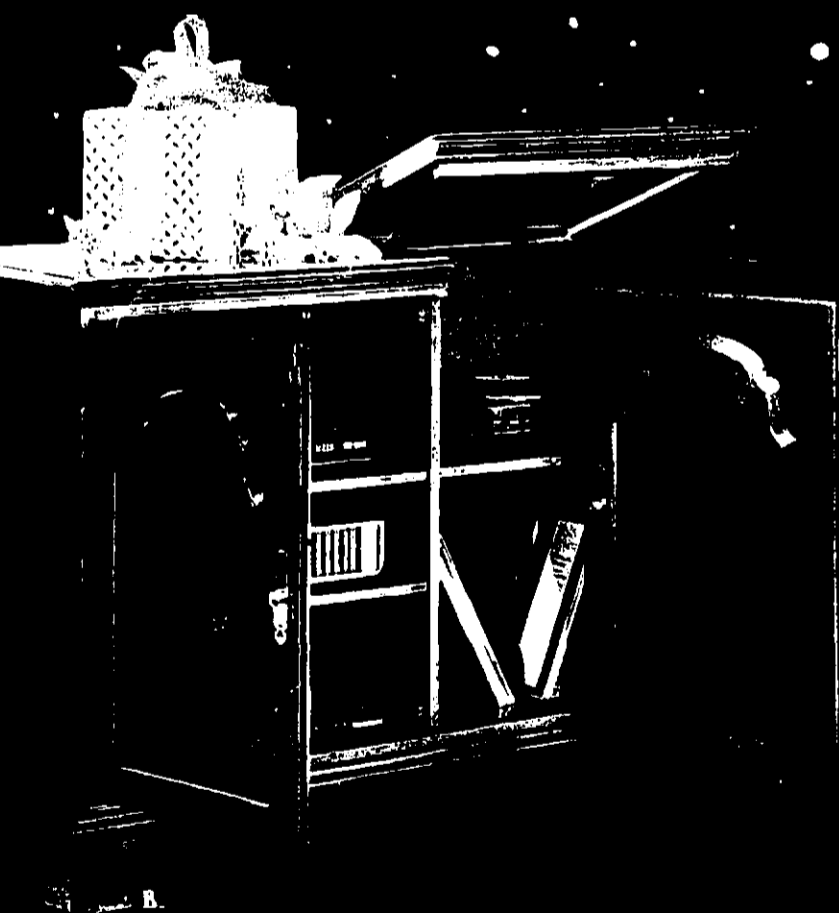

Furnishings precisely engineered for

today's needs...a variety of styles to complement your home

Leave it to Ethan Allen to provide you with superbly engineered, beautifully styled furnishings with a difference. Combining the best of both worlds - superior craftsmanship and high-tech efficiency. Now you can store and display all your audio/visual components - and still harmonize with your room setting.

- A. **SAVE \$60.00 ON HANDSOME TV, VCR STAND** in Cherry or Maple. Locking drawer stores 36 VHS or beta tapes. Hinged doors allow for easy mobility. 29" W x 16 1/2" D x 25 1/2" H. 18-9050. Reg. \$519.75 Sale \$259.75
- B. **SAVE \$150.00 ON 18TH CENTURY DESIGN CABINET** that houses your stereo system beautifully. Stores three components plus turntable. From our Georgian Court Cherry Collection. 48" W x 20" D x 32" H. 11-9230. Reg. \$1029.75 Sale \$879.75
- C. **SAVE \$100.00 ON HEIRLOOM MAPLE STEREO CABINET.** Store components in style! Has enough space for all your

- equipment including records and tapes. Easy-care protective laminate top. 40" W x 18 1/2" D x 30" H. 10-3574P. Reg. \$599.75 Sale \$322.75
- D. **SAVE \$150.00 ON OUR ELEGANT TV/VIDEO CABINET.** From our Georgian Court Collection. Features hinged doors that fold flush to side of cabinet and a simulated drawer front that drops to reveal pull-out trays for VCR and video game storage. Displays most 19" sets. Crafted in enduring Cherry. 30" W x 22 1/2" D x 37" H. 11-9232. Reg. \$929.75 Sale \$779.75
- E. **SAVE \$190.00 ON OUR PINE ENTERTAINMENT UNIT.** Handsome styling that houses your audio/visual equipment plus records and tapes. Convenient pull-out shelves for TV, VCR or turntable behind shutter doors. 32" W x 78" H. ENTERTAINMENT TOP. 12-4069. Reg. \$699.75 Sale \$322.75
- F. **ENTERTAINMENT BASE. 12-4043.** Reg. \$519.75 Sale \$439.75
- G. ***TOP & BASE SET (2 pcs. shown)** Reg. \$1219.50 Sale \$1029.50

- H. **SAVE \$160.00 ON OUR MAPLE ENTERTAINMENT UNIT.** Open the handsome shutter doors and you'll find a convenient slide-out tray for TV, VCR or turntable. Removable record partitions. In Heirloom Maple with a warm outmaple finish. Base has easy-care protective laminate top. 30" W x 80" H. ENTERTAINMENT TOP. 10-4049. Reg. \$619.75 Sale \$359.75
- I. **ENTERTAINMENT BASE. 10-4559P.** Reg. \$469.75 Sale \$309.75
- J. ***TOP AND BASE SET (2 pcs. shown)** Reg. \$1089.50 Sale \$929.50
- K. **SAVE \$270.00 ON ENTERTAINMENT Chest.** This superbly engineered wall unit features slide-out trays for TV, VCR or turntable. Concealed doors and space for records and tapes. In Great 1776 Maple/Birch. 56" W x 22 1/2" D x 78" H. 18-9027. Reg. \$1849.75 Sale \$1579.75

*Also available with protective laminate top. Manufacturer's suggested resale prices. Optional with retailer.

On Our Cover:

- CHERISHED GIFTS TO GIVE OR ENJOY (shown at left)
- Franklin® Cherry floor clock. 81" H. 11-3052. Reg. \$1899.75 Sale \$1529.75
- Leather chippendale chair. 20" W x 30" H. Reg. \$1049.50 Sale \$869.50
- Leather ottoman. 20" W x 41" H. Reg. \$299.50 Sale \$269.50
- Chippendale chair and ottoman set. Reg. \$1549.00 Sale \$1099.50
- Glass tray floor lamp. 51" H. 09-2142. Reg. \$249.75 Sale \$219.75
- (2) Solid brass candelabras. 12" H. 42-1460. Reg. \$114.95 ea. Sale \$99.75 ea.
- Three Officers framed print. 11" W x 30" L. 07-5721. Reg. \$269.75 Sale \$219.75
- Five piece brass fireplace tool set. 32" H. 12-1510. Reg. \$179.75 Sale \$149.75
- Cherry sunb table. 22" H. 13-8705. Reg. \$359.75 Sale \$289.75
- Oval ceramic bowl. 11" W x 5" H. 43-3803. Reg. \$69.75 Sale \$59.75
- Ceramic boy and girl figurines, pc. 10" H. 43-3811. Reg. \$149.75 Sale \$129.75
- Indo Tabriz wool rug. 5'9" x 8'9". 01-1170. H. Reg. \$1149.00 Sale \$979.75

Ethan Allen

Unique, exciting treasures from near and afar

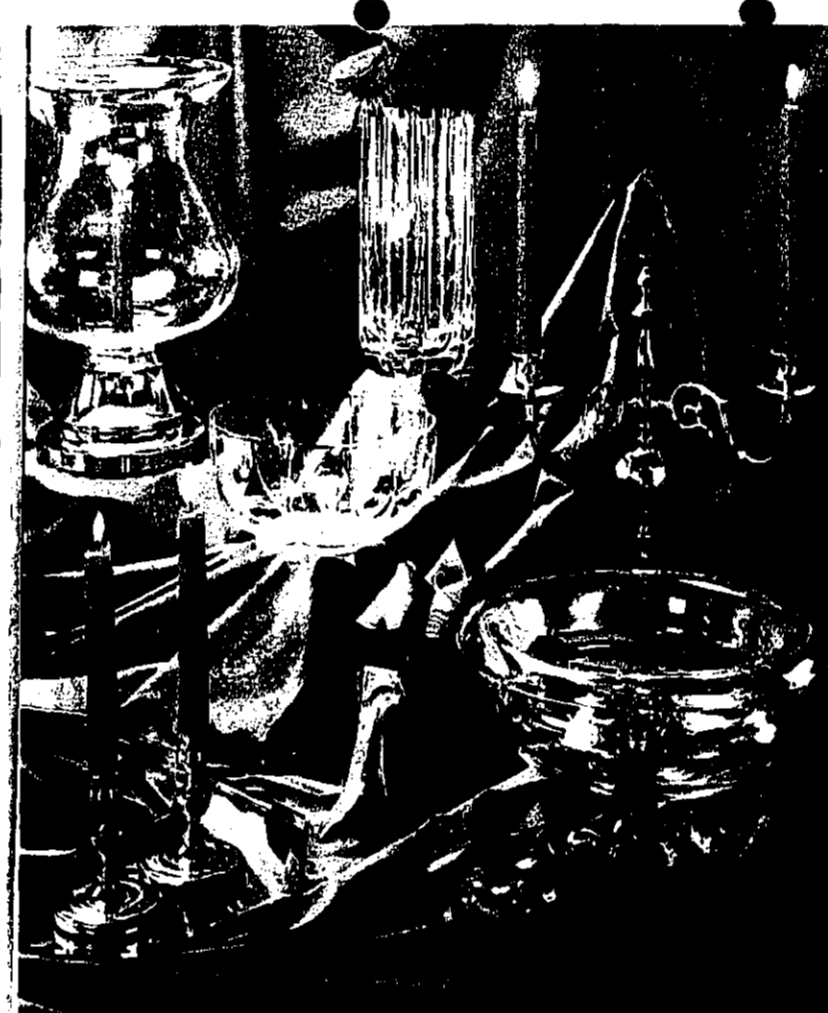
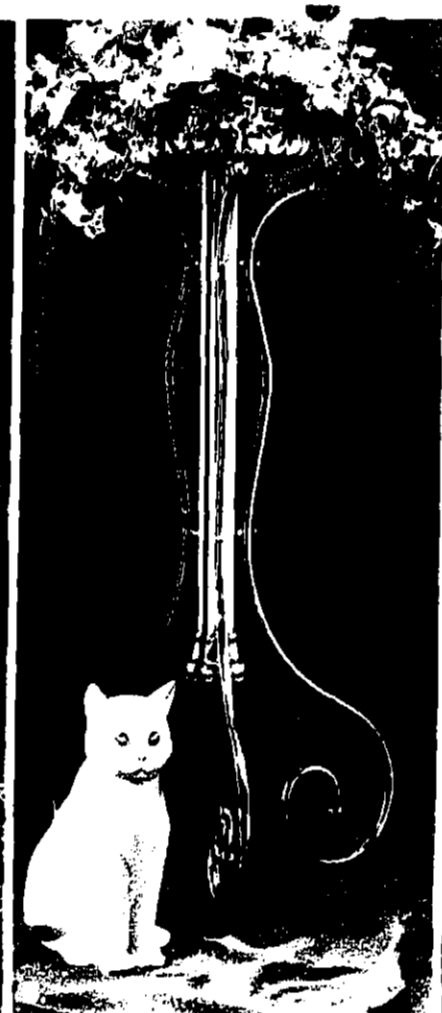
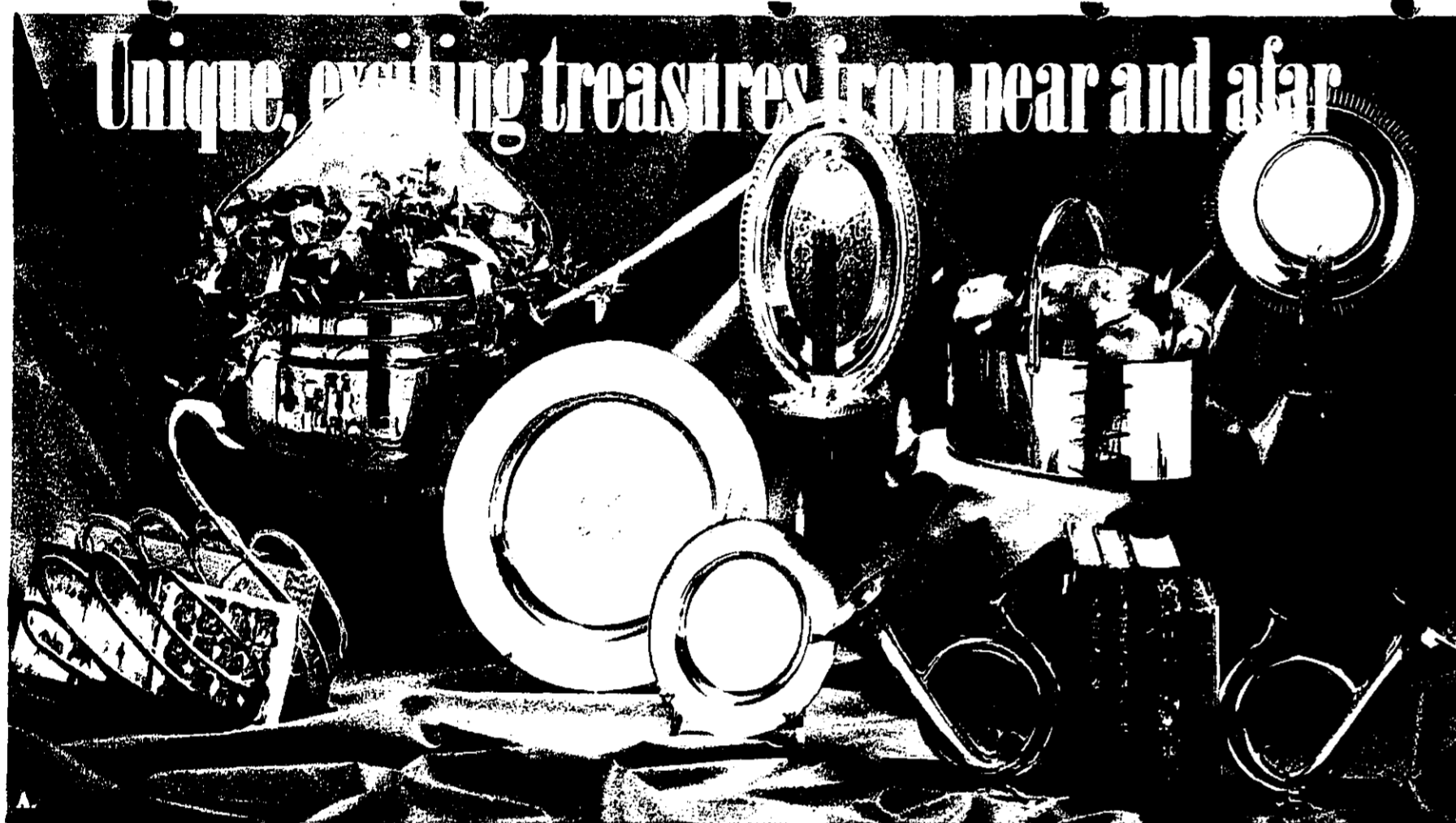

Ethan Allen



Ethan Allen offers you an abundance of unique, extraordinary imported and American-made accessories with a difference! Expressing the skills of talented craftsmen... gleaming brass, decorative ceramic, delicate porcelain and sparkling glass. An extensive selection from casual to formal.

A. VERY SPECIAL SOLID BRASS GIFTWARE
 (Shown left to right):
 SWAN MAGAZINE HOLDER, sleek and imported. 13" W x 11" H. 42-1940. Reg. \$139.75. Sale \$119.75
 WALL PLANTER holds your favorite greenery. Imported. 8" D x 14" W x 18" H. 42-1657. Reg. \$69.75. Sale \$59.75
 ENGRAVED PLATES Imported. 12" D. 42-1830. Reg. \$29.75. Sale \$24.75
 7" D. 42-1831. Reg. \$19.75. Sale \$16.75
 CLASSIC OVAL SCONCE... Americana at its best. 7" W x 16" H. 42-1603. Reg. \$69.75. Sale \$59.75
 SHAKER STYLE BASKET, useful as well as beautiful. 6 1/2" W x 10" H. 42-1934. Reg. \$49.75. Sale \$39.75
 PIEDMONT SCONCE has ceramic inset for added interest. Crafted in the U.S.A. 9 1/2" W x 12" H. 42-1326. Reg. \$69.75. Sale \$59.75

HORN BOOKENDS organize a desk beautifully. Imported. Pr. 8" H. 42-1962. Reg. \$159.75. Sale \$139.75
B. (Shown left to right):
 CERAMIC CAT FIGURINE, imported from Italy. 13" H. 43-3720. Reg. \$69.75. Sale \$59.75
 GLEAMING BRASS FERN STAND. 36" H. 42-1541. Reg. \$129.75. Sale \$99.75
C. (Shown left to right):
 TURNED POST BRASS CANDLESTICKS. Pr. 9 1/2" H. 42-1142. Reg. \$94.75. Sale \$79.75
 MIRRORED OCTAGONAL MATS. 10" Size. 43-6038. Reg. \$17.75. Sale \$14.75
 12" Size. 43-6039. Reg. \$21.75. Sale \$17.75
 14" Size. 43-6040. Reg. \$23.75. Sale \$19.75
 BRASS CANDLESTICKS, polished and lacquered to a brilliant sheen, make an elegant, lasting gift. Pr. 4 1/2" H. 42-1097. Reg. \$59.75. Sale \$49.75
 BRASS HURRICANE with glass globe. 15 1/2" H. 42-1700. Reg. \$69.75. Sale \$59.75

ETCHED GLASS BOWL, perfect for gift-giving. 8" D. 43-6312. Reg. \$59.75. Sale \$49.75
ETCHED GLASS VASE, 10" H. 43-6311. Reg. \$79.75. Sale \$69.75
SALT GLAZE CROCK POT, hand-decorated. 10" H. 43-3514. Reg. \$69.75. Sale \$59.75
SWAN PLANTER, Terra cotta. Imported from Italy. 22" W x 20" H. 43-3814. Reg. \$199.75. Sale \$169.75
HAND-CRAFTED ROCKING HORSE, 15" L x 11 1/2" H. 43-7040. Reg. \$64.75. Sale \$54.75
CERAMIC BASKET, 16 1/2" L x 12 1/2" W x 9 1/2" H. 43-3715. Reg. \$99.75. Sale \$79.75
PORCELAIN VASE with delicate swirl design. Imported from West Germany. 5" W x 8 1/2" H. 43-3761. Reg. \$29.75. Sale \$24.75
CERAMIC DUCK TUREEN, complete with lid, platter and ladle. A great hostess gift! Made in Italy. 1" W x 10" H. 43-3793. Reg. \$89.75. Sale \$69.75
GLASS FISHTAIL VASE, 17" H. 43-6315. Reg. \$79.75. Sale \$69.75
ITALIAN CERAMIC IMPORTS, hand-painted and decorated with floral designs.

BRASS CHAMBERSTICK, an American classic, crafted in the finest Ethan Allen tradition. 3 1/2" H. 42-1133. Reg. \$28.75. Sale \$24.75
ETCHED GLASS BOWL, perfect for gift-giving. 8" D. 43-6312. Reg. \$59.75. Sale \$49.75
ETCHED GLASS VASE, 10" H. 43-6311. Reg. \$79.75. Sale \$69.75
SALT GLAZE CROCK POT, hand-decorated. 10" H. 43-3514. Reg. \$69.75. Sale \$59.75
SWAN PLANTER, Terra cotta. Imported from Italy. 22" W x 20" H. 43-3814. Reg. \$199.75. Sale \$169.75
HAND-CRAFTED ROCKING HORSE, 15" L x 11 1/2" H. 43-7040. Reg. \$64.75. Sale \$54.75
CERAMIC BASKET, 16 1/2" L x 12 1/2" W x 9 1/2" H. 43-3715. Reg. \$99.75. Sale \$79.75
PORCELAIN VASE with delicate swirl design. Imported from West Germany. 5" W x 8 1/2" H. 43-3761. Reg. \$29.75. Sale \$24.75
CERAMIC DUCK TUREEN, complete with lid, platter and ladle. A great hostess gift! Made in Italy. 1" W x 10" H. 43-3793. Reg. \$89.75. Sale \$69.75
GLASS FISHTAIL VASE, 17" H. 43-6315. Reg. \$79.75. Sale \$69.75
ITALIAN CERAMIC IMPORTS, hand-painted and decorated with floral designs.

PITCHER AND BOWL SET 10 1/2" H. 43-3785. Reg. \$99.75. Sale \$79.75
CANNISTER SET includes 7", 9" and 11" H jars for flour, sugar, coffee, more. 43-3786. Reg. \$129.75. Sale \$109.75
WATERING CAN, 11" H. 43-3788. Reg. \$49.75. Sale \$44.75
BASKET 9" W x 10" H. 43-3789. Reg. \$49.75. Sale \$39.75
SINGLE LIGHT HURRICANE SCONCE in gleaming brass. 5" W x 10" H. 42-1093. Reg. \$67.75. Sale \$49.75
G. (Shown clockwise):
OVERSIZED PORCELAIN VASE with floral design. 22" H. 43-3764. Reg. \$219.75. Sale \$179.75
SOLID BRASS WINE COOLER, holds your finest vintage. 9 1/2" H. 42-1211. Reg. \$99.75. Sale \$79.75
SOLID BRASS TRAY at your service for entertaining or gifting. 10" sq. 42-1812. Reg. \$42.75. Sale \$34.75
H. (Shown clockwise):
SIX-LIGHT TRUMPET CHANDELIER in solid brass for a holiday glow. 27" W x 22" H. 09-3254. Reg. \$99.75. Sale \$79.75
RIDGEFIELD KEYWIND CLOCK in solid Cherry with warm Mahogany finish. 9" W x 24" H. 41-2029. Reg. \$299.75. Sale \$249.75
FINE TRANSLUCENT PORCELAIN imported from Italy. Each embellished with rich 23K gold "leaf" design and trim.
SERVING TRAY 15" L x 10" W. 43-3770. Reg. \$79.75. Sale \$69.75
COFFEE POT 7" H. 43-3776. Reg. \$39.75. Sale \$34.75
DEMITASSE CUPS & SAUCERS: set of four, ea. 3" H. 43-3774. Reg. \$49.75. Sale \$39.75
DESSERT PLATES: set of four, ea. 8" D. 43-3773. Reg. \$39.75. Sale \$34.75
VASE, 12" H. 43-3772. Reg. \$79.75. Sale \$69.75
 Manufacturer's suggested resale prices, optional with retailer.

Skilled artistry for your home



Convenience. Find everything for your home or that someone special on your holiday gift list at Ethan Allen. Discover a selection of handsomely framed prints unequalled by many art galleries. Superior crafted mirrors. Or, choose exquisite pillows, bedspreads to complement a gleaming brass bed. For a gallery-full of gift ideas promising a lifetime of enjoyment visit your Ethan Allen Gallery.

- A. **WATER LILIES AND CLOUDS**, a lovely framed Monet reproduction. 28"W x 31"L. 07-5728. Reg. \$194.75. Sale \$159.75
- B. **A RICHLY DETAILED MIRROR**, hand-carved and finished in antiqued gold metal leaf. 29"W x 46"H. 07-1107. Reg. \$309.75. Sale \$339.75
- C. **HOOSICK RIVER** framed landscape, a Grandma Moses' reproduction. 33"W x 22"L. 07-5700. Reg. \$149.75. Sale \$119.75
- D. **THE OLD CHECKERED HOUSE IN WINTER**. Framed winter scene from original by Grandma Moses. 34"W x 30"L. 07-5705. Reg. \$169.75. Sale \$139.75
- E. **GARDEN**... printed on canvas and framed for a genuine oil painting look. 42"W x 31"L. 07-5736. Reg. \$259.75. Sale \$219.75
- F. **QUEEN ANNE STYLE MIRROR**. Hand-carved wood molding enhanced with gold metal leaf. 27"W x 40"H. 07-4600. Reg. \$329.75. Sale \$279.75
- G. **ON THE VERANDA** framed lithograph. 32"W x 31"L. 07-5711. Reg. \$219.75. Sale \$179.75
- H. **GLEAMING BRASS FINISH FRAMED MIRROR**. 37"W x 37"H. 07-4103. Reg. \$149.75. Sale \$124.75
- J. **EVENING LIGHT** framed print. 37"W x 33"L. 07-5732. Reg. \$184.75. Sale \$159.75
- K. **SAVE \$250.00 ON SAVANNAH BRASS BED**. Extremely strong and long-lasting solid brass with impressive die castings and a special baked tarnish-resistant finish. Headboard 54" high. FULL SIZE. * 13-5600-4. Reg. \$1549.75. Sale \$1299.75
- L. **SOFT AND LUXURIOUS THROW PILLOWS** in a variety of colors. Silk/polyester. 21" square. 06-8760. Reg. \$30.00 ea. Sale \$24.75 ea. *Comparable savings on twin, queen and king sizes.

Space saving wall systems with a difference



Flexibility. The Ethan Allen difference. Expressed in an exclusive modular Custom Room Plan System. Quality-crafted and designed to mix, match, adjust as your needs change. Now... your choice of Pine or Maple at attractive savings.

Your Choice \$1349.75

(Heirloom or Antiqued Pine 5-Pc. Wall System)

- A. **SAVE \$329.00! 5-PC. MAPLE 100" WALL SYSTEM**. Our Heirloom Collection... for storage, display and workspace. Bases have easy-care laminate tops. Individual components (shown left to right): (2) 30" Upper bookcase units. 10-4019. Reg. \$234.75 ea. Sale \$194.75 ea. 30" Shutter door cabinet. 10-4511P. Reg. \$369.75. Sale \$299.75 40" Four-drawer student desk. 10-4550P. Reg. \$469.75. Sale \$399.75 30" Three-drawer chest. 10-4510P. Reg. \$369.75. Sale \$299.75 Comb back swivel mate's chair. 10-6051.* Reg. \$149.75. Sale \$129.75 Pieces available in daffodil yellow or alabaster white at slightly higher prices. *Not included in five-piece wall system.
- B. **SAVE \$349.00! 5-PC. PINE 104" WALL SYSTEM**. Antiqued Pine creates a casual look, ideal for a student bedroom, home office or den. Individual components (shown left to right): (2) 32" Upper bookcases, 12-4036. Reg. \$274.75 ea. Sale \$229.75 ea. 32" Shutter door cabinet, 12-4031.† Reg. \$369.75. Sale \$299.75 40" Four-drawer student desk. 12-4052.† Reg. \$409.75. Sale \$339.75 32" Three-drawer chest. 12-4030.† Reg. \$369.75. Sale \$299.75 Swivel mate's chair. 12-6020.* Reg. \$214.75. Sale \$179.75 †All bases available with protective laminate or wood top. *Not included in five-piece wall system.
- C. **FRAMED LITHOGRAPHS BY HEIDE DAHL**. "STRAWBERRY BASKET". 19"W x 22"L. 07-1059. Reg. \$79.75. Sale \$67.75 "WHITE FLOWERS WITH RED BERRIES". 19"W x 22"L. 07-1038. Reg. \$79.75. Sale \$67.75
- D. **"BASKET BLOSSOMS" FRAMED ETCHING**. Handcolored. 27"W x 25"L. 07-3064. Reg. \$179.75. Sale \$149.75
- E. **COMFORTABLE, STURDY STACKING STOOLS**. Hardwood with Antiqued Pine finish frame. Durable easy-clean Naugahyde® vinyl. 17" square. 9"H. 12-7500. Reg. \$39.75. Sale \$35.75 Manufacturer's suggested resale prices optional with retailer.

Ethan Allen

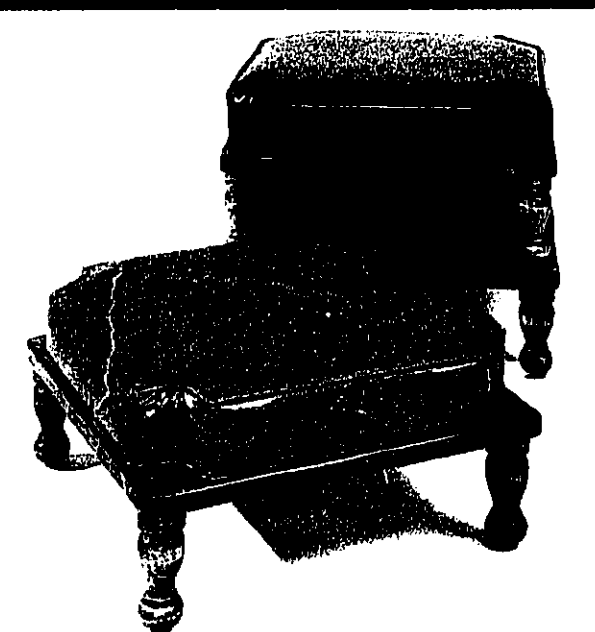

SAVE \$60.00

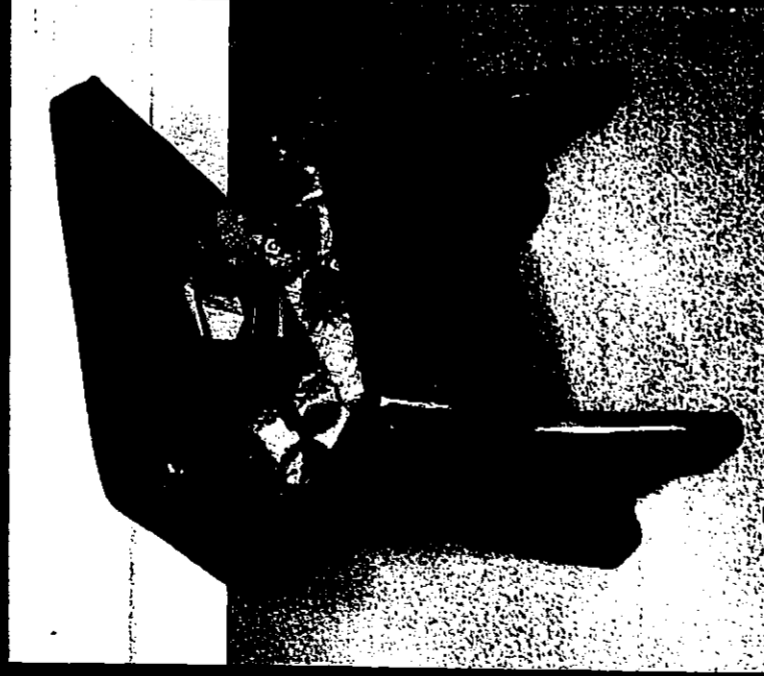

SAVE \$60.00 ON SPACI SAVING FOOT STOOL
A great hiding place for toys, magazines, more!
Padded black vinyl top is hinged for easy access.
In Pine and Maple with mellow rich finish.
21" x 15" x 17" D.V. H. 12-3002.
Reg. \$129.75 Sale \$69.75

SAVE \$120.00



SAVE \$120.00 ON FURNITONAL CHAIRSIDE CHAIR.
Carefully proportioned to make the perfect companion for
your favorite easy chair or sofa. Three spacious drawers
provide thoughtful storage. From our Circa 1776 Collection in
enduring Maple. 25" x 17" x 22" H. 18-9012.
Reg. \$579.75 Sale \$259.75
Manufacturer's suggested resale prices, optional with retailer.

SAVE \$60.00

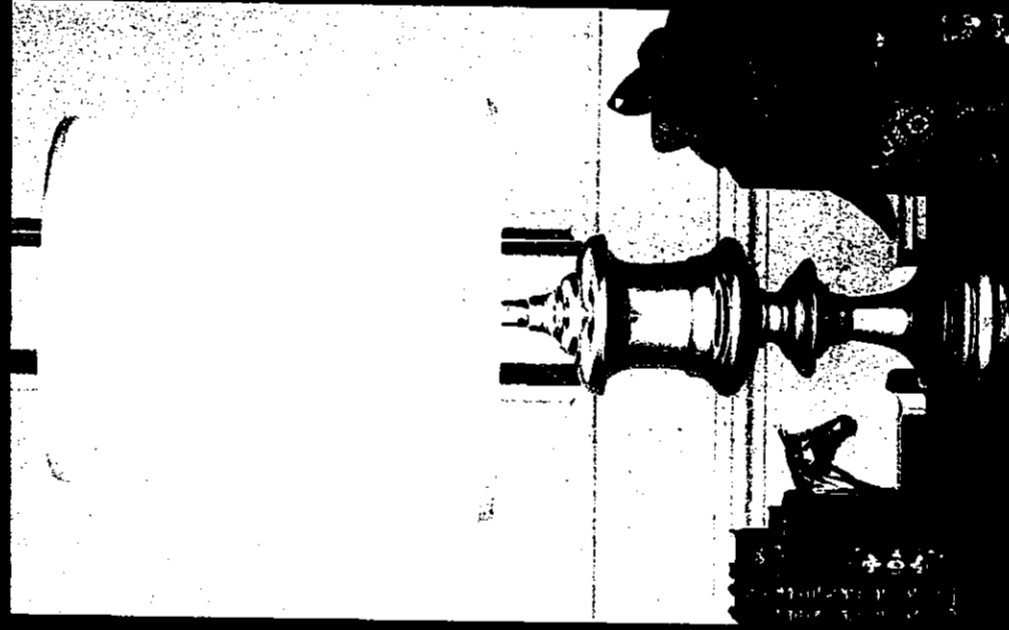

SAVE \$60.00 ON OUR CLASSIC LAMP.
Our graceful hand-cast metal table lamp puts
the accent on beauty... for yourself or someone
extra special. Its classic design is pleasing to
any room setting, any decor. In a glowing
polished bronze finish topped with a mushroom
pleated shade. 32" H. 09-1890.
Reg. \$139.75 Sale \$79.75

Very Special Holiday Values!

A GIFT FOR YOU... COMPLEMENTS OF ETHAN ALLEN!
Ethan Allen offers you the exciting new 240-page Ethan
Allen Treasury absolutely FREE! You'll find page after
page of dramatic room settings... in magnificent full
color. From formal to casual... from furniture to fabrics
to home fashions, you'll find hundreds of ideas
to beautify your home. Come in. Ask for your
free copy now... no purchase necessary.



Ethan Allen

SUPPLEMENT TO OBSERVER, NOVEMBER 6, 1986

Georgetown Manor

Member of Interior Design Society
LIVONIA 15700 Middlebelt Rd. 261-7780
UTICA 50170 Van Dyke
Between 5 & 6 Mile Rds. Between 22 & 23 Mile Rds.
254-5260

Open Mon./Thurs./Fri. til 9 • Tues./Wed./Sat. til 5:30 • Sunday 1 til 5

268-2