

Bow taken from hunter's home

A resident on Maudlin in the north end of the city might have trouble trying to bag a deer this season — his compound bow was stolen from his residence during a break-in that occurred Sunday, Nov. 8, between 4 and 8:15 p.m.

Police Beat

The resident told police he arrived home to find that unknown individuals had broken in through a living room window. Investigating officers said the responsible parties gained entry by cutting the screen, then reaching in to push up the wood frame window.

Once inside, the thieves had access to the entire house but appear to have removed only the compound bow and related archery equipment which had been left in the living room. Stolen property was valued at \$250.

FOUR MCGREGOR sweaters were stolen from a display rack at the United Shirt store at Twelve Oaks Mall on Sunday, Nov. 8, at approximately 3:20 p.m. The theft was reported by a clerk who told security officers she observed a man and a woman looking at the sweaters on a display rack at the front of the store.

As she began walking toward the front of the store to offer assistance, the couple turned around and left, the clerk reported. Upon arriving at the sweater rack, the clerk said she observed that several sweaters were missing.

The man was described as a black male, approximately 5'7" tall and weighing 165 pounds, and a black female, standing approximately 5'6" tall. Stolen property was valued at \$100.

A **PAIR OF** women's corduroy jeans were stolen from the Lane Bryant store at Twelve Oaks Mall on Sunday, Nov. 8, at approximately 3:35 p.m.

The man was described as a black male, approximately 5'11" tall and weighing 165 pounds. One was said to be wearing a stone-washed denim jacket, while the second was said to be wearing a navy blue jacket. The stolen jeans were valued at \$29.

DESIGNER SUNGLASSES valued at \$89 were stolen from Tuckerman Optical at Twelve Oaks Mall on Sunday, Nov. 8, at approximately 3:35 p.m.

An employee told security officers she believed the sunglasses were stolen by a man who had been standing by a rack displaying the sunglasses. After he exited the store, the clerk checked the rack and discovered the sunglasses missing.

The suspect was described as a white male, approximately 5'9" tall

and weighing 160 pounds. He was said to be wearing jeans and a dark-colored jacket. The suspect appeared to be with a second white male who was described as being approximately 18 years old and having dark hair.

Stolen were a pair of Wilshire-Mira sunglasses valued at \$89.

A **FAST-TALKING** customer may have fast-talked a clerk into giving him a \$10 bonus at the Squiggles and Giggles store at Twelve Oaks Mall on Saturday, Nov. 7, at approximately 6 p.m.

The clerk said the man approached the counter to purchase an item valued at 80 cents with a \$20 bill. She said the man talked very fast and kept changing the subject frequently as she was attempting to count his change as if he were trying to confuse her.

Before she handed over the change from the \$20 bill, the clerk said the man produced a second \$20 bill and requested that she change it for him.

After the man had left the store, the clerk said she realized she had given him \$10 more than he had coming.

The man was described as a black male, approximately 5'9" tall with a thin build.

A **CANVAS CAR** cover was stolen from an automobile parked outside the owner's residence on Fountain Park in the Fountain Park Apartments during the night of Nov. 7-8. Stolen property was valued at \$157, according to reports.

A **BRIGHTON WOMAN** reported that unknown individuals broke into her 1986 AMC Wagoner while it was parked in the Blue Lot at Twelve

Oaks Mall on Nov. 3 between 12:15 and 2:40 p.m.

The incident was reported by a Stolen were a Cellular One telephone receiver and an Escort radar detector valued at \$250.

A **DISPUTE** OVER a parking space is believed to have led to an incident of vandalism in the Blue Lot at Twelve Oaks Mall on Sunday, Nov. 1, at approximately 1:10 p.m.

The incident was reported by a Farmington Hills man who said he and his fiancée had arrived at the mall in his 1987 Cadillac Brougham and were following three cars down the cruise lane in search of a parking space.

The man said the cars were moving slowly and he passed them in a safe manner. Shortly later he observed an empty parking space and pulled his vehicle into it.

At this time, the man reported, the driver of one of the cars he had passed drove by and waved her hand in an abusive manner. The man said he and his fiancée exited their vehicle and proceeded into the Lord & Taylor store, but he remained at the door because he feared the driver of the second car might attempt to damage his vehicle.

As he was watching, the man said he observed two women get out of the second car and watched one of them press her hand against his vehicle as she walked past. He also reported that he had seen a key in her hand after she walked out from behind the Cadillac.

The man said he summoned mall security, walked to his car, observed two scratches on the side of it and then confronted the two women.

The individual accused of having vandalized the vehicle was described as a white female, approximately 5'3" tall and weighing 135 pounds. She also was pregnant. The second individual was described as a white female, approximately 50 years old with grey hair.

Novi Briefs

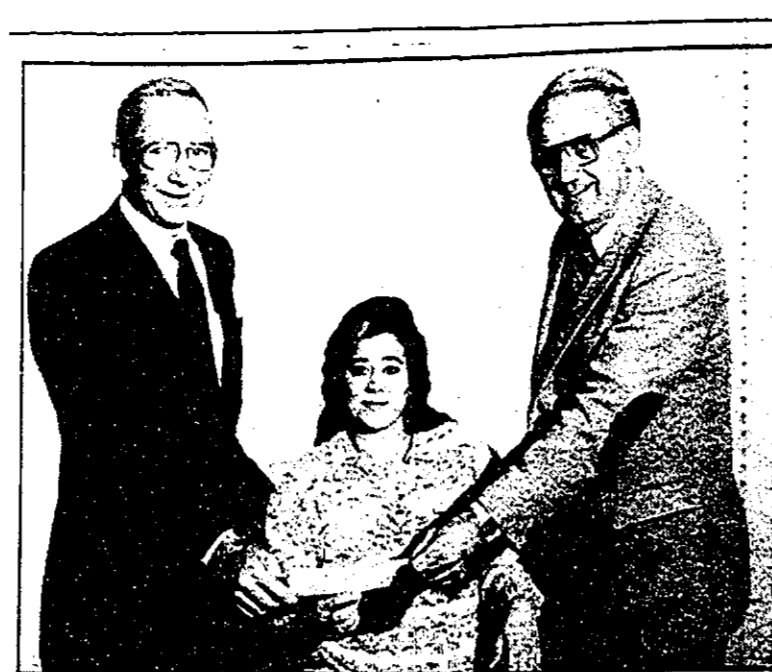

More help for Vanda: Nobody can say Novi residents are not big-hearted. Just ask Vanda Muscatello, the woman who was left paralyzed by the tornado which struck the Chateau Estates Mobile Home Park last June. Killing her husband and injuring her son.

In the picture above, John A. Boli, chief executive officer of Chateau Land Development Company, (left) presents Don Greengood of Security Bank and Trust with a check for \$27,828 for the Vanda Muscatello Benefit Fund.

Since June, Chateau has raised the \$27,828 from its various vendors and suppliers as well as private individuals. Chateau matched the amount of the donations, making the total contribution to \$55,656. Chateau's donation has brought the Muscatello benefit fund to more than \$100,000.

Thanksgiving Day Parade: The award-winning Novi Wildcat Marching Band will be participating in Detroit's Thanksgiving Day Parade on Thursday, Nov. 26, again this year.

The parade will proceed down Woodward Avenue from the Fisher Freeway to westbound Jefferson Avenue. A contingent of Novi band parents and band supporters is planning to gather at the Renaissance Center to watch the parade and cheer on the band. Anyone who plans to attend the parade and would like to join the Novi group can obtain times and directions from Rick and Diane Cox at 349-7884. The group will mark its position by holding up a green "Novi" flag.

In addition to performing in the parade, the Wildcat Band will compete against top high school bands from across the state at Cobo Hall on Wednesday night, Nov. 25.

They also serve: It takes all kinds of people to make a successful school district — and that includes secretaries, teachers aides, bus drivers and cafeteria workers, too.

The Novi Community School District took time yesterday (Wednesday, Nov. 18) to honor the contributions of its support personnel. The recognition came in conjunction with American Education Week (Nov. 15-21) which had designated Wednesday as National Educational Support Personnel Day to recognize the many contributions made by these members of the educational team.

Commented Mary Hatwood Futrell, president of the National Education Association: "Without education support personnel, education could not take place in an environment conducive to learning."

Lone gunman robs Total gas station

A lone gunman held up the Total gas station at Ten Mile and Novi Road at approximately 3:30 a.m. on Sunday, Nov. 15.

Detective William Brown of the Novi Police Department reported that the man made off with a small amount of cash.

According to police reports, the attendant was alone in the station, filling up the soft drinks racks with his back to the door, when he heard a noise behind him.

When he turned around, the attendant found himself staring at a gun pointed at his face.

Without saying a word, the robber motioned with the gun toward the cash register and the attendant proceeded to the counter and opened the cash register for the intruder who subsequently removed its contents.

The gunman then told the attendant to get the key to the back office. After unlocking the office, the attendant walked inside and the gunman shut

the door behind him and proceeded to make his escape. Brown said the man left in an unknown vehicle and an unknown direction.

The attendant told police the robber was wearing a nylon stocking over his head and face. The man was described as being a white male, approximately 6'0" tall and weighing 200 to 210 pounds.

The man was approximately 40 years of age and had a receding hairline. He was said to be wearing a blue jacket and a red flannel shirt.

COUNTRY IN THE INN
MEADOWBROOK HALL
November 20 & 21, 1987
Friday: 4 p.m.-9 p.m.
Saturday: 10 a.m.-5 p.m.
Admission \$3.00

Shorwell Gustarson Pavilion
Rochester, MI
Kathy Yuchasz, 313-538-1057

EARLY AMERICANA FOLK ART SHOW

Need Someone To Talk to? "Lets Talk"
AFFORDABLE COUNSELING
624-5169
Susan Kopriva - Licensed Counselor

UGLY KITCHEN CABINETS?
DON'T REPLACE... **"REFACE"**
MODERN & EUROPEAN STYLES
FORMICA Solid Colors and Woodgrain
SOLID WOODS Oak, Cherry and Birch

SERVING WAYNE, OAKLAND & MACOMB
• FACTORY SHOWROOM
• FREE ESTIMATES
1642 E. 11 Mile Rd., Madison Hgts. Since 1968
1 Block W. of Dequindre Daily 9-5, Sun. 10-4
Cabinet Glad... 541-5252

SPECIAL DELIVERY FLEXSTEEL FINE UPHOLSTERED FURNITURE at **SCHRADERS**
It's NOT TOO LATE to buy new Flexsteel furniture and have it delivered to your home for the holidays!

\$699⁹⁹ Specially priced...
Cozy and comfortable Country styling you'll want to share with your best friend or a solitary cup of coffee. This smartly tailored sofa is wing-backed, button detailed and luxuriously cushioned. Comfort has never looked better than this. **MATCHING LOVE SEAT \$649⁹⁹**

\$849⁹⁹ Specially priced...
Lavish traditional beauty, crafted with up-to-date quality and value! Timeless beautiful styling with roll arms and graceful camel-back, crafted with kiln-dried hardwood frame and a patented spring system. **MATCHING LOVE SEAT \$799⁹⁹**

Schradler's HOME FURNISHINGS
"Family owned & operated since 1907"

111 N. Center St. (Sheldon Road) Northville 349-1838
Mon., Tues., Sat. 9 to 6; Thurs. & Fri. 9 to 9; Closed Wed.

FOR THE YEAR-ROUND COMFORT AND HEALTH OF YOUR FAMILY
OIL HEAT IS BEST
THE ADVANTAGES OF OIL HEAT ARE NUMEROUS

- OIL HEAT IS—SAFE—QUIET—CLEAN—and ECONOMICAL. Four of many major advantages.
- OIL HEAT—Lets YOU CHOOSE your own QUALIFIED INDEPENDENT DEALER.
- OIL HEAT—Lets YOU store your own supply of fuel—as you wish.
- OIL HEAT—GIVES YOU FULL CAPACITY in coldest weather, WITHOUT PRESSURE OR POWER DROP. MORE HEAT when YOU REALLY NEED IT!
- OIL HEAT IS DEPENDABLE—backs by years of experience and customer satisfaction.
- OIL FIRED FURNACES—are easily adaptable for AIR CONDITIONING, ELECTRONIC AIR CLEANING, and HUMIDITY CONTROL—A TRULY TOTAL COMFORT SYSTEM.
- OIL HEAT IS—backed by QUALIFIED SERVICE—As near as your phone.

ELY FUEL, INC.
YOUR FULL SERVICE COMPANY
Since 1920
316 N. Center, Northville 349-3350
a member of the Michigan Petroleum Association.

REMEMBER!... We are the Fuel that Does Not Charge \$6.50 per month service charge.

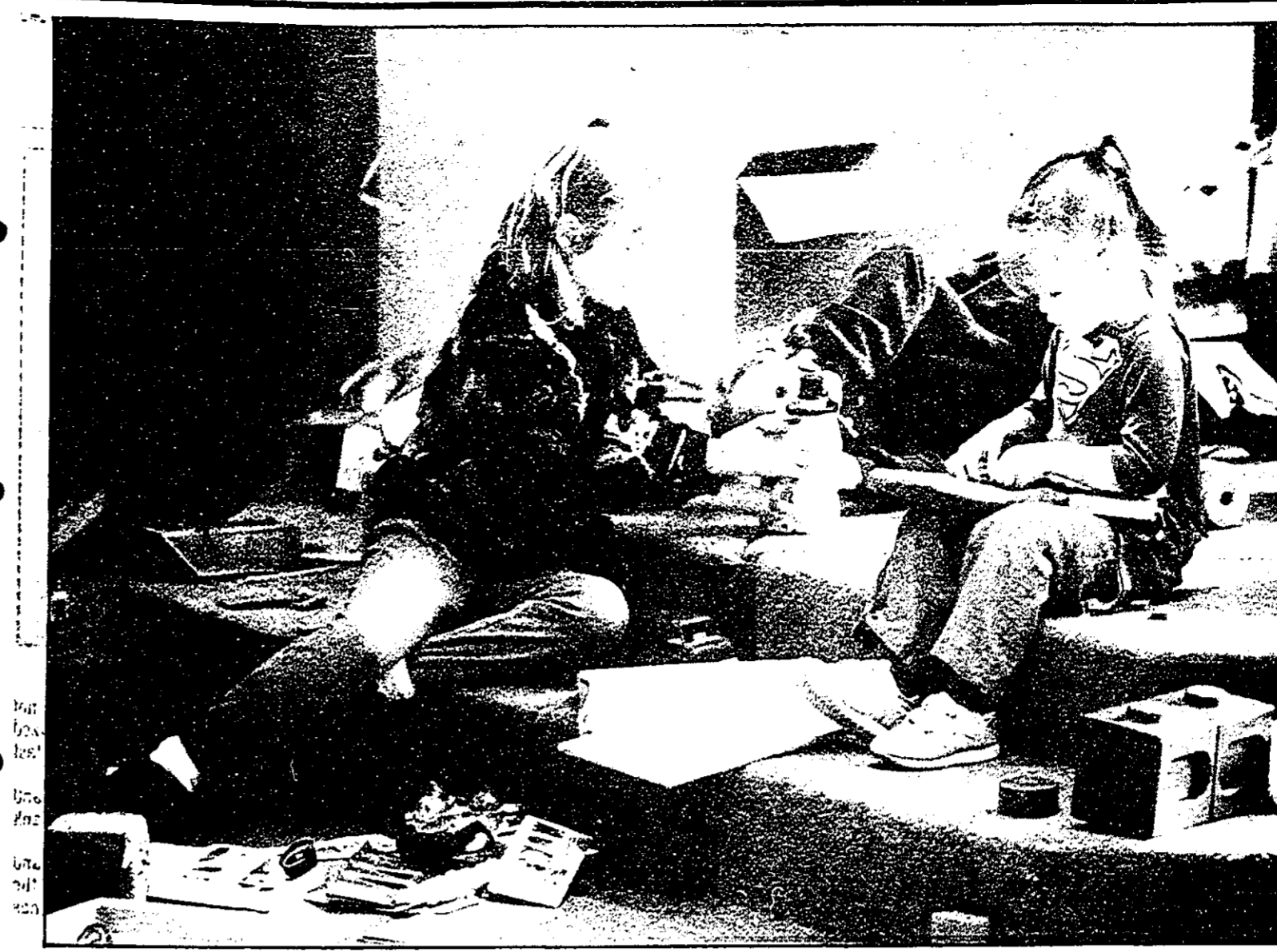

Toy inspectors

Kids across the country know the best part of having your mom assist with a rummage sale is that you get to test all the toys that have been donated for the sale. And children at the Faith Community United Presbyterian Church are no exception. Jessica

Slating, Lori Watkins and Erika Slating (above, left to right) are pictured testing some of the toys at the recent Faith rummage sale to make sure they were in good working order before being sold.

Novi News/CHRIS BOYD

Holiday service at Meadowbrook

A community-wide ecumenical Thanksgiving Eve Service will be held Wednesday, Nov. 25, at 7:30 p.m. at Meadowbrook Congregational Church.

The church is located on Meadowbrook Road between Eight and Nine Mile.

Various churches throughout the Novi community will participate in the service. A combined six-church choir will sing during the service under the direction of Ray P. Ferguson, professor at Wayne State University and director of music at Meadowbrook Congregational. Directors of music for all participating churches also will participate.

Needy can apply for holiday help

The Salvation Army of Farmington Hills will be accepting applications for Christmas assistance from needy families in the Novi area on Tuesdays, Nov. 24, Dec. 1 and 8, from 11 a.m. to 5 p.m.

Representatives will be stationed at Novi Fire Department Headquarters at 42975 Grand River, just east of Novi Road.

The assistance consists of clothing and toys for children 12 years and under and food for needy families. Persons applying for assistance must bring a driver's license or Michigan identification card, social security number and birth certificate for children or Medicaid card. Proof of residency must be shown (utility bills are accepted) and proof of income in the form of a recent pay stub, unemployment card or Medicaid benefits card, must also be presented.

Also served by the Novi application dates are residents in the New Hudson, Walled Lake, Franklin, Farmington Hills, Farmington and portions of Southfield areas. For further information contact the Salvation Army offices at 477-1153.

Defer billing until after the holidays with Holiday Money.
25% to 40% off
D R E S S E S

Save now on thousands of dresses for endless needs. Dresses for work, for fun, for dancing, for parties, for now, for later, for weekends, for — by this time you've caught on. You'll find selected dresses of special prices in Misses, Penies, Women's World, and Juniors sizes, many by designers and famous makers. Orig. \$48 to \$250, now 34.97 to \$54.97. Near all styles in all sizes. Also, choose from a fabulous selection of silk jacquard dresses by Argenti. A special purchase, only \$9.99, \$12.98 (see us at all Hudson's stores).

HOLIDAY MONEY
Defer billing until after the holidays on qualifying purchases of \$40 or more, including mail and phone orders.

HUDSON'S
USE YOUR HUDSON'S SHOPPING CARD, VISA, MasterCard, The American Express, Card or Discover Card.
HUDSON'S OPEN MON - SAT 10-9 OPEN SUNDAY 12-5

SNEAK PREVIEW
BLUE HERON POINTE
Northville's New Luxurious Lakefront Condominiums
Sales Office Now Open
Mon., Tues., Fri., & Sat. 1p.m.-5p.m.
Sunday Noon-5p.m.

DIRECTIONS: One Mile West Of Downtown Northville on Beck Road 1/2 Mile South of Seven Mile
SALES OFFICE: 344-8808 624-8110

Join Us For The Fun
South Lyon's Annual CHRISTMAS WALK
Sunday, November 22nd 12-5 p.m.
Shops will be open throughout the City of South Lyon

VILLAGE TO SHOPS
CANTON

Donate Blood.
American Red Cross

Downtown NORTHVILLE

SUNDAY NOV. 22

PARADE STARTS 1:00 P.M.



CENTER ST.

Judy's
Decorating and More
107 N. Center

The Warmth Of The Holiday Season Is Here!
Curtains-Wallpaper-Point Country Accessories
(Formerly Greens) 348-3520

NOW OPEN

KITCHEN WITCH
107 N. Center
Downstairs in Judy's

The Kitchen Witch
GOURMET COOKWARE
Utensils, "Gift Baskets" Palette Pleasers
348-0488

PAINTER'S PLACE
140 N. Center

ORIGINAL ART
by G. DUMPHY

Original Watercolors
House Portraits
Northville Christmas Cards
348-9544

VILLAGE SWEETS 'N TREATS
124 N. Center

ADVENT CALENDARS

UNIQUE TOYS and GIFTS

WEST END CO.
Lamps/Accessories

Our November SALE Continues

142 N. Center
LAMP & LAMP SHADES 10% OFF
SELECT GROUP CUSTOM LAMP SHADES 30% OFF
PILLOWS SAMPLERS & MORE 10-40% OFF

SPARR'S

NOW OPEN IN NORTHVILLE
SANTA PARADE SPECIAL
ROSES \$7⁹⁵

GREENHOUSE And FLOWER SHOP
156 N. Center
347-0088

For Holiday Decorating
DOOR SWAGS AND OUR OWN POINSETTIAS
Free ROSE With Mylar & Latex Balloons

DUNLAP ST.

NORTHVILLE WATCH & CLOCK

GENUINE BLACK FOREST CUCKOO CLOCKS
From \$79⁹⁵
132 W. Dunlap
349-4938

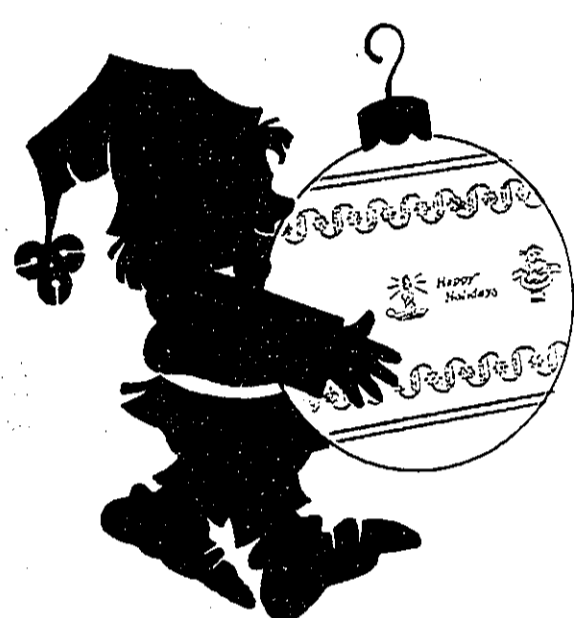

Season's Greetings



If you haven't thought about Christmas yet, there's no better time than now! We've done everything to help you wrap up your holiday shopping quickly and conveniently. Plus we've decked all the halls and trimmed all the trees with the most festive sights around. Come join us for a holiday shopping spree as we celebrate the merriest season of cheer!

MAIN ST.

1 Ct. Total Weight
TENNIS BRACELETS
Specially Priced from \$995
Use Our Convenient Lay-A-Way For Christmas
All Major Credit Cards Honored
101 E. Main
349-6940
Brighton Mall Brighton
25317 Ford Rd Garden City

We invited you to visit our quaint shop over-flowing with Colonial/Country Furniture and accessories for a warm charming atmosphere

Williamsburg Inspirations
102 E. Main
349-1550

GENITTIS
108 E. Main

DAVID WINTER COLLECTION
SANDICAST COLLECTION
YEAR ROUND CHRISTMAS SHOP

GREETING CARDS & GIFT WRAP
LARGE SELECTION OF COUNTRY PRINTS
(Sorry-No Lunch on Sunday)
349-0522

Handcrafters Unlimited
342 E. Main 348-0130
Come and Browse

CHRISTMAS ARTS & CRAFTS SHOW
Fri., Dec 11, Sat Dec 12 10-9
Northville Rec Ctr., Adm. '1.00

Freydl's
Men's & Ladies Wear
SANTA PARADE SPECIAL Sat & Sun Only
WINTER COATS
Men's & Womens **30% OFF**
112 & 118 E. Main

BOOKSTALL ON THE MAIN
116 E. Main
BOOKS ..

A Wonderful Idea For Gift Giving
We Feature The Area's Best Selection Of Children's Books

The Marquis Theatre
Presents LIVE ON STAGE
Peter Pan
Come Fly Away To Never-Never Land!
135 E. Main
Tickets in Advance by Telephone
349-8110/349-0868
Visa, American Express, Mastercard
Tickets Also At The Door Of The Marquis Stores

IV SEASONS
FLOWERS & GIFTS
WREATHS & ROPING
10% Off Orders By Nov. 25
CEDAR & PINE ROPING
22 60 Ft. Roll
149 E. Main 349-0671

MAIN ST.

Teles Clothing and Shoes
141 E. Main
153 E. Main

PARADE OF VALUES
4 Days Thurs-Sun
Save 25-50%
Entire Stock Both Stores

Longs Fancy Bath Boutique

WELCOME!
We Will Be Open Sunday's Til Christmas
(Except Nov. 29)
190 E. Main
349-0373

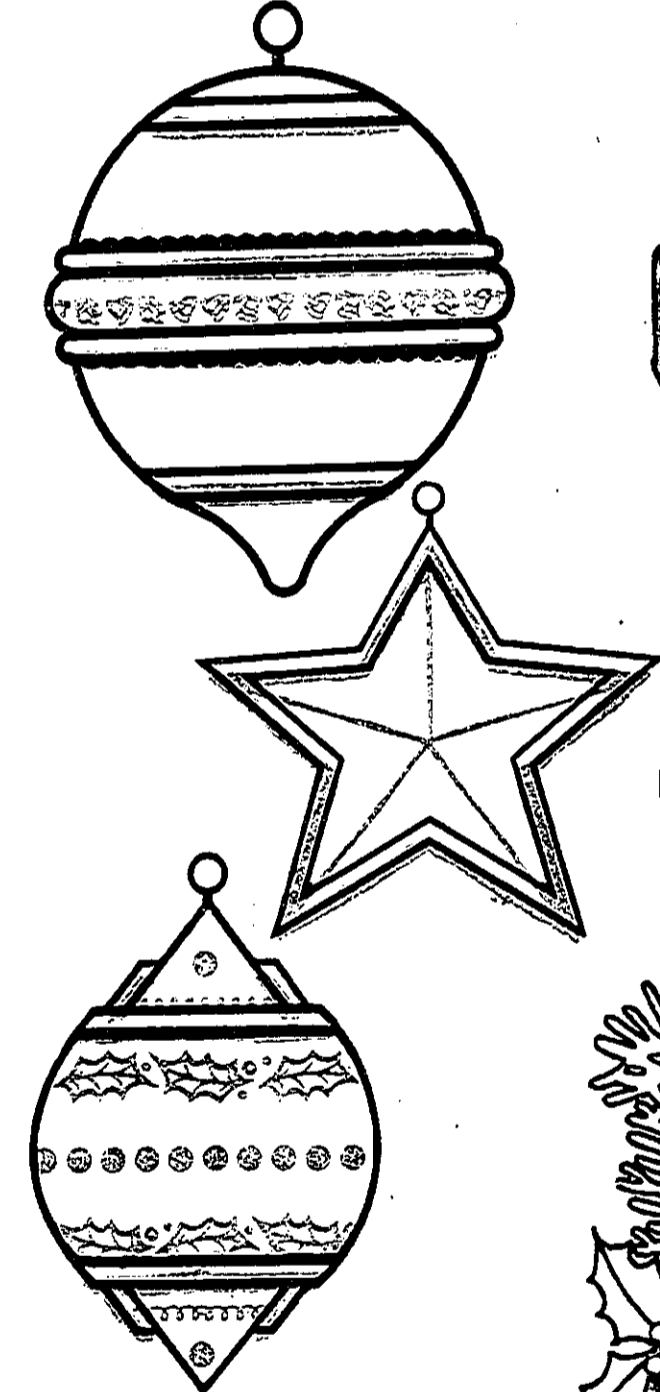

MARY ALEXANDER CT.

HOLIDAYS ARE SWEETER AT JOSEPH'S
Special Orders Welcome

Cakes•Pies•Breads Muffins & More...
144 Mary Alexander Ct.
344-1515

PEDDLERS * FOUR

THE BEST OF Country Christmas
Santas, Trees & More
150 MARY ALEXANDER CT.
348-4446

GRAND OPENING OF PICTURES PLUS GALLERY

FRAMED PICTURES CUSTOM FRAMING VISIT US SOON
154 Mary Alexander Ct.

THE HOLIDAY SEASON CONTINUES...MOST SHOPS WILL BE OPEN NOON-5PM EXPERIENCE OLD-FASHIONED CHRISTMAS CHARM

CADY ST.

NORTHVILLE GALLERY OF FLOWERS

Creative Holiday Arrangements
Pick Up Your FREE FTD 1988 Calendar
135 E. CADY 349-3811



FOR FURTHER
INFORMATION

347-0960

**TAKE FIVE
VIDEO**

LOCATION: **TEN MILE
AT NOVI ROAD**

TAKE: SCENE: DIRECTOR: CAMERMAN: **COMING
SOON**

Want Ads
INSIDE

Providence introduces 'Special Dentistry' program



Dr. Marie Clair (left) performs general dentistry in an operating room setting at Providence Hospital

People with unusual needs in dental treatment can be cared for in a unique program at Providence Hospital under Marie Clair, DDS, of the family dentistry staff of the Providence/Novi Center.

Called "Special Dentistry," the program provides general dental care for handicapped or retarded patients who cannot understand or participate in their dental treatment. Also included are patients who for other reasons cannot be treated in the usual dental office situation.

Special dentistry patients receive care under general anesthesia in one of Providence's outpatient surgery rooms.

"There is a real need for this kind of service," said Dr. Clair. "Many retarded or handicapped people have chronic dental abscesses and gum or periodontal disease which is extremely painful. Their dental health is sometimes neglected for years because of other health problems or because of the difficulties in giving dental care. And problems multiply when proper brushing and flossing are not done."

Finding a dentist who will treat such patients presents another problem.

"Most general dentists can't take care of retarded patients because of the behavioral problems that are involved," said Dr. Clair. "Patients often won't or can't sit still. Many are frightened of the equipment and the setting."

"Communication also can be difficult, so treating them under general anesthesia in an operating room is a good solution. In five hours or so, I can do as much general dentistry — fillings, extractions, cleaning — as might be accomplished in five or six office appointments."

To qualify for dentistry in an operating room setting, Dr. Clair studied with Sinai Hospital's staff in their department of dental and oral surgery. Providence's department of anesthesia and the resident staff provided necessary medical support in administering anesthetics and in doing physicals and histories for Dr. Clair's patients.

"We hope to expand this service as more people learn of it," said Dr. Clair. "There is a genuine need. Families, especially, express their gratitude when dental care for a handicapped or retarded family member is no longer a worry."

For more information about Special Dentistry, call Family Dentistry at Providence Hospital's Novi Center, 471-0345.

SEVERSON'S MILL & FARM SUPPLY
56675 Shepo Road • New Hudson, Michigan 48165
Mon-Sat (313) 437-1723 Live Stock Hauling
9-6 Langs Dealer • Complete Pet Supplies
Complete Line of Carnation Feeds
• Custom Feed Made Daily
In the Historical New Hudson Elevator

THE IAMS COMPANY
We Carry Iam's and Lang's Dog & Cat Food

We also carry Archery Targets

Fletcher & Rickard
LANDSCAPE SUPPLIES INC
437-8009 54001 Grand River 437-8009
New Hudson, Michigan 48165
Hours: Mon-Fri 9-6; Sat 9-5; Sun 11-3

YOUR CALLS AND LANDSCAPING CENTER
We deliver by the wheelbarrow or the back — We deliver 7 days a week. Full service lawn care and maintenance. Full, 1/2, 3/4, 1-ton, 2-ton, 3-ton, 4-ton, 5-ton, 6-ton, 7-ton, 8-ton, 9-ton, 10-ton, 11-ton, 12-ton, 13-ton, 14-ton, 15-ton, 16-ton, 17-ton, 18-ton, 19-ton, 20-ton, 21-ton, 22-ton, 23-ton, 24-ton, 25-ton, 26-ton, 27-ton, 28-ton, 29-ton, 30-ton, 31-ton, 32-ton, 33-ton, 34-ton, 35-ton, 36-ton, 37-ton, 38-ton, 39-ton, 40-ton, 41-ton, 42-ton, 43-ton, 44-ton, 45-ton, 46-ton, 47-ton, 48-ton, 49-ton, 50-ton, 51-ton, 52-ton, 53-ton, 54-ton, 55-ton, 56-ton, 57-ton, 58-ton, 59-ton, 60-ton, 61-ton, 62-ton, 63-ton, 64-ton, 65-ton, 66-ton, 67-ton, 68-ton, 69-ton, 70-ton, 71-ton, 72-ton, 73-ton, 74-ton, 75-ton, 76-ton, 77-ton, 78-ton, 79-ton, 80-ton, 81-ton, 82-ton, 83-ton, 84-ton, 85-ton, 86-ton, 87-ton, 88-ton, 89-ton, 90-ton, 91-ton, 92-ton, 93-ton, 94-ton, 95-ton, 96-ton, 97-ton, 98-ton, 99-ton, 100-ton.

Replacement Kerosene Heater Wicks & Accessories

Dan's Auto Repair
43151 Grand River
348-1230

Lifetime Guarantee
Brake Pads \$29.97 per wheel
Metallic Extra Most Cars

Model L4000 Generac Generators
Retail Sale \$6500
\$1045

- Heavy duty 6,000 maximum watts
- 4,000 continuous watts
- Full power plugs on 120 & 240 volt
- Gas gauge
- 4-5 gal. gas tank, runs up to 9 hours
- Lo-oil alert
- Roll cage to protect unit
- Overload breakers
- 8 hp Briggs & Stratton engine
- Rubber isolated mounts

New Hudson Power
53535 Grand River at Haas Cash and Carry
2 miles east of Pontiac Trail (313) 437-1444
Hours: Mon-Fri 9-6, Thurs 'til 6, Sat 9-6

South Lyon Collision Inc.
"In Business to Serve you better"

150 E. McHattie South Lyon
437-6100
or
437-3222

EARLY BIRD CHRISTMAS CRAFT FAIR
1987
Saturday, November 21
10:00 a.m. to 5:00 p.m.
Hazel National Guard Armory
725 Laurel Rd., Novato, CA 94945
LIVE MUSIC, PRIZES, FOOD
Sponsored by United Way Agency
Admission Free

USO — Service is our middle name. We serve 2 million military personnel and their 3 million dependents stateside and overseas. Our goal is to improve morale and insure the well being of military personnel.

A United Way Service

SNOW FIGHTERS
Combat winter's worst with our John Deere snow removers

We make lawn tractors into all-around tractors

Add a John Deere snow thrower to a 100 Series Tractor, and you have a year-round worker. You clear snow in minutes while saving wear and tear on yourself. Stop in and see our snow thrower and tractor combinations.

From \$3499.75 for a 185 with 38" Snowthrower

(313) 348-3224
348-5151

MIDWEST TURF & SUPPLY CORP.

Thomas Gallagher
TURF POWER EQUIPMENT
PARTS • SALES • SERVICE

41787 Grand River, Novi, MI 48050
348-4228

ERA RYMAL SYMES
There Really Is A Difference In Real Estate Companies

NOVI — Country Tudor — Distinguished yet honey 2 story. Meticulous upkeep, brick, Cherry fireplace, cathedral ceilings, walk-in closets, 4 bedrooms, 2 1/2 baths, automatic sprinkler system, large view deck, double entry doors, Foyer, Main-level laundry, food storage area — A Country haven! \$174,900. Call 478-9130

NOVI — Country living with city conveniences at your fingertips. Privacy & seclusion are yours in this unique 5 bedroom, 3 bath spacious ranch with finished walk-out. Many quality features. Kitchen in lower level, ideal for mother-in-law quarters. Mini horse farm too! New 40 x 24 Pole Barn and 6' fenced area. Call to see this beautiful home. \$259,000. Call 478-9130

NOVI — Beautifully decorated 4 bedroom, 2 1/2 bath Colonial in desirable area of Novi. Room for the large family or the small family to grow! Nice deck, fenced yard, 2-car garage — just move in and unpack! Excellent schools and close to shopping and X-Ways. \$122,000. Call 478-9130

NOVI — Real Appeal! 2 Story Colonial boasting fireplace warmth, Aluminum siding, Gas Heat, 3 bedrooms, 1 1/2 baths, family room, Nice big country kitchen — plus a 2-car attached garage. See Now — A Genuine Value! \$94,900. Call 478-9130

NORTHVILLE TOWNSHIP — Older home on quiet road. Large roomy Quad with 2 bedrooms and 2 baths. Freshly painted, hardwood floors. Definite possibilities for the right buyer. Great Rental Property. Home protection plan provided. \$85,900. Call 348-4550

NOVI — Hospitable Ranch — You will delight in its brick styling and more. Freshly decorated. Great family area, gas heat, carpeting, custom blinds in living room, 3 bedrooms, 1 1/2 baths, fencing, patio, 2-car garage and more. Near schools and shops. Plus — Decorator upgrades! \$81,500. Call 478-9130

NOVI Office 478-9130 **West Bloomfield Office 851-9770** **Northville Office 349-4550**

Business Briefs



DR. EILEEN MURPHY



DR. JUDITH BEHN

EILEEN MURPHY and JUDITH BEHN have joined the staff at the University of Michigan M-CARE Health Center in Northville. Eileen Murphy, M.D., an obstetrician-gynecologist, and Judith Behn, M.D., an internal medicine specialist, will help meet the growing demand for services at the center, the center announced.

Dr. Murphy, a graduate of the State University of New York Upstate Medical Center, completed her obstetrics-gynecology residency at the Medical College of Pennsylvania. She comes to Northville from a private OB-GYN group practice in Philadelphia. Her specialized post-doctoral work includes courses in cervical pathology, colposcopy and OB-GYN pathology.

Dr. Behn, who received her medical degree from the University of California-Irvine, completed her internal medicine residency at the University of Michigan Medical Center. She currently is on the clinical faculty in the U-M Division of Internal Medicine. Her area of expertise is primary care medicine. The M-Care Health Center in Northville is located at 650 Griswold. For more information call 344-1777.

DOUGLAS TEUBERT, FIC, of Northville has completed all requirements to be certified as a qualifying member of the 1987 Million Dollar Round Table.

Teubert is a district representative for Lutheran Brotherhood, a fraternal benefit society. He joined in 1981 and is associated with the Karl Mueller Agency headquartered in Rochester.

The Million Dollar Round Table is an independent association of more than 15,000 life insurance agents, each of whom must meet strict ethical and production requirements in order to qualify. Only three percent of the world's life insurance agents are certified each year through high-level client service and production.

DONNA RACHUNOK has been named sales representative by Skyline Inns for its properties in Novi and Southfield. Rachunok is the daughter of Mr. and Mrs. Alex Rachunok of Northville. A graduate of St. Alphonsus High School in Dearborn, she currently resides in Birmingham.

A native of Detroit, Rachunok will service corporate and group accounts for the two hotels which are part of the Skyline Inns chain of upscale, rooms-only properties in the eastern United States.

Rachunok brings three years hotel sales experience to the position. She has served as sales manager for the Kingsley Inn of Bloomfield Hills and director of sales and marketing for the Quality Inn of Pontiac.

A business and psychology major from Oakland University, she is a member of the American Civil Liberties Union, National Organization of Women and Metro Photographers Association. Her background includes a wide range of work. She is founder of the Oakland Crisis Center in Pontiac and served as a staff investigator and reporter for Oakland University's Pigeon Consumer Advocate Group.

The 112-room Skyline Inn in Southfield and the 128-room Skyline Inn in Novi offer business class rooms-only lodging and amenities that include free continental breakfasts, premium satellite television, toll-free reservations, photocopy service and desk-top work space.

For families, the chain allows children under 18 to stay free in their parents rooms and provides free cribs. Rooms for the handicapped and no-smoking rooms also are available at each hotel.

JAMES S. FRISBIE III of Northville has been named a lecturer in Lawrence Institute of Technology's School of Technology.

Frisbie received his Bachelor degree in Packaging from Michigan State University and a Master of Business Administration degree from the University of Iowa.

In addition to his teaching responsibilities at LIT, he is a supervisor in the department of material handling engineering for Ford Motor Company in body and assembly operations.

CERYL KEHRES-DIETRICH of Northville has been promoted to project hydrogeologist in the Ann Arbor office of Soil and Materials Engineers, Inc. The promotion was announced by Richard O. Anderson, P.E., senior vice president of the consulting engineering firm headquartered in Livonia specializing in geotechnical, hydrogeology and geodynamic engineering and construction material quality control and testing.

Kehres-Dietrich's responsibilities have included performing evaluations and coordinating hydrogeological projects for such projects as the Ann Arbor Landfill and the proposed regional distribution center for Meijers, Inc. in Monroe County.

As project hydrogeologist she also will be providing technical support at project sites and directing environmental site assessments for property transfer transactions.

Kehres-Dietrich's background includes bachelor's and master's degrees in geology with specialization in hydrogeology from Michigan State University. She has been an instructor at MSU and Wayne State University, and has considerable field experience at hazardous waste disposal sites and at EPA Superfund sites.

Since joining SME, she has been responsible for a variety of services related to hydrogeology, leaking underground storage tank projects, environmental assessments and landfill projects. She and her husband, Matt, live in Northville.



LORRAINE AND CHUCK FARR of Northville accept the keys to a 1988 Dodge Caravan from Tom Buehner, manager of the new Mervyn's store in the Novi Town Center.

Mervyn's awarded a total of eight mini-vans to lucky customers at each new Michigan store to celebrate its October grand opening. Mervyn's is a valued-oriented family department store specializing in soft goods, including a wide variety of quality private label and name brand goods.

Mervyn's has seven other Michigan locations in Dearborn, Lansing, Livonia, Okemos, Pontiac, Shelby Township and Westland.

PHILIP J. MOROSCO has been appointed general manager of Twelve Oaks Mall in Novi by The Taubman Company, Inc.

Based in Bloomfield Hills, The Taubman Company is the nation's leading shopping center developer which owns and operates 20 centers across the country.

Morosco comes to Twelve Oaks with nine years as a Taubman employee in shopping center operations, most recently as general manager of Briarwood Mall in Ann Arbor for seven years. In Ann Arbor, he served as the 1985 chairman of the Chamber of Commerce and on the council of many advisory boards in the community.

HARRY LANE of Milford, a new salesperson for Northwestern Dodge, Inc. in Ferndale, has received an award for individual performance in selling Dodge vehicles.

Lane also reached the Silver level of recognition in Dodge's Sales Professionals Club.

Specially-designed incentives and awards are provided for outstanding product knowledge and sales achievement at three performance levels — Bronze, Silver and Gold. Membership in each level is determined by points earned for sales of new cars and trucks. The program continues throughout the 1987 model sales year. The top 50 Dodge retail sales personnel will win a trip to a three-day national sales conference.

Self-employed benefit from tax reform

Money Management

The Tax Reform Act of 1986 is now very much a reality. All 900-plus pages of it. And whether you're self-employed or run a sideline business for extra income, there are a number of tax-saving strategies you can follow.

First of all, you should know that if you are self-employed, you stand to benefit from the lower individual tax rates, according to the Michigan Association of CPAs. Because your self-employment profits are included in your personal income, they are subject to the same lower tax rates as individuals. You pay tax on your business profits only at your personal income tax rates. All in all, the self-employed should fare quite well under tax reform.

Because the ordinary and necessary costs of operating a business are tax-deductible, the self-employed individual gets tax breaks that now carry restrictions for the employed worker.

For employed workers, most business-related expenses are considered miscellaneous itemized expenses and as such, are now deductible only to the extent they exceed two percent of a taxpayer's adjusted gross income. Not so for the self-employed worker.

Other tax reform changes that apply to individuals do not apply to businesses. For example, the interest costs of financing a car bought for business remains deductible, even though the corresponding deduction for interest charges is being phased out for individuals. And although individuals can no longer deduct the sales tax paid on a car, the businessperson can add the sales tax to the purchase price and depreciate the total amount.

Beginning this year, self-employed workers get a new deduction. Twenty-five percent of the amount paid for health insurance coverage for themselves and their families can be deducted so long as the deduction does not exceed the business' net earnings. In most cases, if you have employees, you will also have to provide coverage for them to qualify for the new deduction. The law says you cannot qualify for a deduction in any year you are eligible to participate in a subsidized health plan of another employer or through your spouse's employer. This 25 percent deduction is due to expire at the end of 1989.

Consider, too, the tax benefits of opening a Keogh. Keoghs are tax-deferred pension accounts for those who are self-employed either full- or part-time. Keogh contributions are tax-deductible and earnings grow on a tax-deferred basis and are not subject to income tax until withdrawal.

Many self-employed workers take advantage of home-office expenses which continue to be deductible under the 1986 Tax Reform Act, although with a new restriction. As a general rule, to take a tax deduction for business use of your home for purposes, that part must be used exclusively and regularly as:

- the principal place of your business, or
- a place where you meet or deal with your clients, customers or patients.

Under the new law, deductions for business use of the home are allowed only to the extent of the taxpayer's net income from the business — that is, gross income less deductions attributable to the business. Expenses that would be deductible irrespective of business use, such as mortgage interest and property taxes, are disregarded for purposes of this calculation.

Thus, expenses for items such as depreciation and utilities are subject to gross income limitations. If deductible expenses exceed gross income, a carry-over is provided. The net effect of this new limitation is that home office deductions may not be used to create or increase a net loss from the business activity conducted in the home.

The complicated tax laws governing home office deductions are closely scrutinized by the Internal Revenue Service, so you may want to consult with a knowledgeable tax professional before proceeding.

Business equipment can still be depreciated over a number of years, although the tax act generally stretches out the depreciation terms of most equipment. But the lengthened periods are somewhat offset by the new law's increased acceleration method, allowing you a faster rate of depreciation in the initial years.

In general, automobiles which were depreciated over three years under the old law, now use a five-year depreciation period. For other depreciable business assets including machinery, equipment and office furniture, the write-off period generally extends from five to seven years, while the depreciation period for computers remains at five years.

Other business assets may be depreciated over a longer period of time.

Some business owners forego depreciation and choose 'expensing' instead. With expensing, you take an immediate tax deduction for equipment purchases, writing off up to

\$10,000 worth of equipment the first year. This \$10,000 cap became effective on January 1, 1987; prior to that, \$5,000 was the most that could be expensed. The \$10,000 limit applies as long as your business equipment purchases are less than \$200,000 for the year. The \$10,000 amount is reduced dollar-for-dollar where the cost of equipment put into service during the year exceeds \$200,000.

For example, if you purchased \$205,000 worth of equipment, the most you could 'expense' would be \$5,000. The amount eligible to be expensed is limited to taxable income from the active trade or business in which the property is used.

Another tax strategy you may use as a self-employed worker is to hire your spouse and/or children. If the work they perform is legitimate and the amount you pay is reasonable, you can deduct the amount of their wages on Schedule C. And you don't have to make Social Security payments on behalf of your spouse or children under 21.

Be aware however, that beginning in 1987, an individual who is eligible to be claimed as a dependent on another taxpayer's return will no longer be allowed to claim a personal exemption on his or her own return.

Workers with net self-employment earnings of \$400 or more must pay self-employment tax — a Social Security tax for self-employed individuals. Your self-employment tax payments contribute to your coverage under the Social Security system. For 1987, the maximum amount subject to self-employment tax is \$43,800.

The Tax Reform Act of 1986 is sweeping to say the least, making it more important than ever for the self-employed to have a good professional support group to assist in creating a comprehensive financial plan that minimizes taxes.

Detroit Edison maps Oakland's industries

Detroit Edison has helped put Oakland County on the map. To help attract business to Oakland County the utility, in conjunction with Oakland County's Department of Community and Economic Development, has developed the first map of the county showing all industrial and research parks.

The colorful, easy-to-read map identifies the location and size of each industrial and research park in the county and is designed to assist businesses looking for a new location, according to David Chick, economic development specialist for Detroit Edison's Oakland Division.

"Pinpointing a strategic site is a major part of locating a business. There has never been one central listing of all the county's industrial and research parks on a map for quick and easy reference," Chick said.

"The map helps businesses put each park's location and size into perspective. It shows where parks are clustered, identifies surrounding communities and highlights transportation links, such as highways and railroads, that serve the parks."

The map will be distributed to developers, Realtors, local governments and economic development professionals who have an interest in doing business in Oakland County.

Oakland County has more than 90 industrial and research parks totaling more than 5,500 acres. There are more than 185 such parks in the tri-county metropolitan Detroit area.

For further information about locating a business in Oakland County or to receive a copy of the industrial and research parks map, contact Detroit Edison at (313) 645-4293 or the Oakland County Department of Community and Economic Development at (313) 658-0722.

Carpet Sale

Used Auto Show Carpet **\$1.00** yd. to **\$4.95** yd.

Dupont Certified Antron by Milliken

STAINMASTER CARPET

100's of Remnants in stock and special orders available

MILLIKEN'S Remarkable dry carpet cleaner captures.

Donald E. McNabb Company
437-8146 or 357-2626
31250 S. Milford Rd.
North of I-96 at Exit 155 (Milford Rd.)
Milford

For your convenience: Mon.-Sat. 10 a.m.-9 p.m. Closed Sunday

WOODLAND GOLF CLUB

18 Holes — Bar & Grill

7635 W. Grand River
Brighton, MI

(313) 229-9663

Woodland CALL NOW FOR 1987 CHRISTMAS PARTIES

Now Playing November "DAKOTA" 19-20-21 & 27-28

ENTERTAINMENT & DANCING Thur-Sat

No Cover
Thursday Ladies Night 1/2 Off On All Drinks

Coming Events "Tracey Lynne" & The Mountain Express December 3-5

Fabulous Friday Fish Fry \$3.95 All You Can Eat

LIFE'S A BEACH.

...Until the floodwaters of a hurricane rip through town, leaving hundreds homeless. If you can't spare even a few dollars to help... you ought to be ashamed.

American Red Cross

Windjammer

THANKSGIVING DAY BUFFET

SERVED 11:30 TO 5:30 PM
Reservations Suggested
PHONE 227-4400

A FESTIVE FEAST, including

- Soup: Cream of Asparagus - Turkey Rice
- Roast Beef - Turkey - Ham
- Baked Potato - Stuffing - Pineapple Stuffing
- Rice Pie - Mash Potato & Gravy
- Broccoli Casserole - Yams - 3 Bean Salad
- Pasta Salad - Cranberries - Mix of Veggies
- Tossed Salad - Jello Mold - Pumpkin Pie
- Apple Pie - Mincemeat Pie
- Fruit Display

\$8.50 Adults \$4.50 Children Under 10

8180 W. Grand River
Located 1/4 Mile West of I-96
Exit 145, Grand River Exit, Brighton

GRAND RIVER EQUINE FEEDS

51680 Grand River • Wixom • (313) 348-8310
Hours: Mon.-Fri. 8:00am - 5:00pm; Sat 8:00am - 2:00pm

Horse Feed • Hay • Straw
Custom Mixed Horse Feeds Starting at \$1.00 per 100 lb.
Quantity Price Breaks Available

While You Wait!
Now Handling Iams Pet Foods

Dog & Cat Food • Wild Bird Seed • Poultry Feed • Horse Supplies • Wood Shavings • Straw

Spectacular Sale

With Free Leather Pouch

Model M-2R
Reg. \$15.85 **Sale \$9.95**

DUCT TAPE \$3.50
Reg. \$5.50 **Sale \$3.50**

STANLEY HEAVY DUTY UTILITY BLADES \$1.15
Reg. \$1.75 **Sale \$1.15**

SKIL 7 1/4" CIRCULAR SAW \$42.50
Model No. 5150
2 1/2 HP
Retailer \$55.60 **Sale \$42.50**

New Hudson Lumber
56601 Grand River
New Hudson 437-1423
Mon.-Fri. 8:30-5:30; Sat. 8-4

SANTA'S HERE!

Hey Kids! I'll be at Palm Beach on Saturdays from 2-4 p.m. Starting November 21. Don't Miss Me!

Palm Beach Patio Furniture

5 Miles W. of Telegraph
Near Pontiac Airport
666-2880

Custom VERTICAL BLINDS

50% to 75% OFF

Selected Shade Cloths & P.V.C.

6" P.V.C. Vertical Doorwall \$41.95 off white color.
Discount Up to 75% Off Pvc Flat
Up to 75% Off

Width & Height	Compare	Colorite Vertical	Compare	Colorite Vertical
47 X 48 1 way	\$187.00	\$46.75	\$154.00	\$41.58
72 X 84 1 way	\$353.00	\$88.25	\$262.00	\$70.74
84 X 84 1 way	\$375.00	\$93.75	\$287.00	\$77.49
112 X 84 1 way	\$497.00	\$124.25	\$375.00	\$101.25

All Other Custom Sizes at Equal Savings
New, Heavy Duty Vertical Rod with 10 Year Guarantee

WALLPAPER 20% to 30% Off **Save 30% to 40% ON CARPET**

JOERINS Colorite DECORATING CENTER
666 E. Huron St., Milford 685-7055

WALDECKER'S Quality Collision Repair

We Repair **All Makes and Models**

"We'll Treat Your Car Like Our Very Own"
FREE ESTIMATES

We Use Manufacturer's Parts.

WALDECKER'S PONTIAC • BUICK
7685 W. GRAND RIVER BRIGHTON MI 227-7161

FUELISH OFFER

FREE GAS FOR 2 MONTHS WITH EVERY LONG-LIVED BRYANT FURNACE WE INSTALL BEFORE JANUARY 31.

Now's a bargain time to get a new deluxe model Plus 90" furnace with up to 97.3% energy efficiency. Because we'll pay you back for your two highest monthly gas bills of the season after installation. And our easy-term financing makes the best equipment available even more affordable. Offer valid only from participating dealers from now until January 31, 1988. Call today for details.

1987—Custom Sheet Metal **bryant** Hot Water Heaters
LONG LIFE RUNS IN THE FAMILY.

CALL TODAY **FALLERT HEATING & COOLING**
437-4385
Sales Service

FOR YOUR Holiday MEALS

Hickory Smoked **WHOLE BONELESS HAMS \$2.39** lb
Bone In **\$1.29** lb
OLD FASHIONED HAMS \$3.99 lb
Peeled Whole **BEEF TENDERLOIN**

FRESH AND SMOKED HOLIDAY SAUSAGES — MADE TO ORDER

EXPERT DEER PROCESSING
Custom Made Venison Sausage

CHOICE PACKING CO.
10665 Six Mile (1/4 mi. W. of Napier) Northville
349-4448 Mon.-Sat. 8:30-5 p.m.

Hot on the Trail.

The 1988 Exciter is the hottest performance sled on the trail.

- Lightweight design for excellent response and maneuverability
- Unique wide-tracked track design provides excellent traction in all snow conditions
- Superior ergonomics for improved rider position, comfort, and performance
- 569cc liquid-cooled, two-stroke engine
- The quickest-accelerating Yamaha over

YAMAHA We make the difference.

BAKER'S LAWN & LEISURE
1155 Milford Rd., Highland (313) 887-2410
Mon.-Fri 9 to 6 Sat. 9 to 4

COMPLETE BODY REPAIR

FREE Estimates

Frame Repair - Collision Bumping - Painting

GM QUALITY SERVICE PARTS Keep That Great GM Feeling With Genuine GM Parts.

SUPERIOR Olds • Cadillac • GMC Truck
8282 W. Grand River Brighton 227-1100

Red Wings STICK GIVEAWAY

Wings vs. Boston Bruins
—SUNDAY—
NOV. 22 • 7PM
Joe Louis Arena

First 3,000 youngsters 14 years & under will receive a street-style hockey stick.

Redemption coupons distributed upon entry.

Tickets are available at Joe Louis Arena Box Office, all Ticketmaster locations including AAA offices.

For information call (313) 567-6000
GROUP SALES (25 or more) (313) 567-7474
courtesy of

Tubby's Sub Shops Watch the Wings
5 WKBD
Dec. 7 & Dec. 14

To Place Your Action Ad One Local Call Does It All... Monday Green Sheet Wednesday Green Sheet Pinckney, Hartland, & Fowlerville Shoppers

- 313 227-4436
517 548-2570
313 348-3022
313 437-4133
313 685-8705

Sliger/Livingston on Publications GREEN SHEET EAST CLASSIFIED ACTION ADS

Deadlines Monday Green Sheet Fri. 3:30 p.m. Wednesday Green Sheet Fri. 3:30 p.m. Wednesday Green Sheet Mon. 3:30 p.m.

RATES GREEN SHEET PLUS 3 ACTION ADS 10 WORDS FOR \$5.99

Classified Display absolutely FREE

001 Absolutely Free FILL dirt. All you need. You don't want to waste money.

010 Special Notices CHRISTMAS is coming at our doorstep. Our elves are busy making beautiful hand-made cards.

011 Special Notices LUCSON ARIZONA 'Land of the Sun' February 20 to March 1. 14-day air package.

012 Bingo NOVENA to St. Jude May the sacred heart of Jesus be revered, glorified, loved and preserved throughout the world now and forever.

013 Lost TWO male Britany's White and orange, 1 1/2 year old.

014 Real Estate FOR SALE BRIGHTON. Lake privileges. Classy sub. Beautifully decorated, custom vinyl treatments.

015 Houses BRIGHTON 3 bedroom large country kitchen, lake privileges, Buck Shore Drive on 2 acres.

016 Houses BRIGHTON Schools: Open house! Sunday, November 22, 1987. Unique Farm house on 2 acres.

017 Real Estate FOR SALE BRIGHTON. Lake privileges. Classy sub. Beautifully decorated, custom vinyl treatments.

018 Houses BRIGHTON. Lake privileges. Classy sub. Beautifully decorated, custom vinyl treatments.

019 Houses BRIGHTON. Lake privileges. Classy sub. Beautifully decorated, custom vinyl treatments.



NORTHVILLE OAKS CONDOMINIUMS \$74,900 & \$77,900 Experience living in scenic Northville Oaks. Beautifully picturesque hilltop views overlook the serenity and elegance of downtown Northville and its charming lifestyle.

Horse Farms Only A Real Estate Company There are 3,288 Brokers that sell Houses... Only 'Horse Farms Only' does Horse Farm Property Exclusively!



REAL ESTATE FOR SALE BRIGHTON. Lake privileges. Classy sub. Beautifully decorated, custom vinyl treatments.

44931 Byrne Drive (S. of 9 Mi. & W. of Sheldon Rd.) Brick three bedroom ranch on beautiful large lot.

8779 Napier Road (between six and seven mile) 17 acres and a four bedroom brick home.

Beautiful vacant 2 1/4 acre estate property located on Cambridge Drive across from Meadowbrook Country Club.

Century 21 EAST, INC. at 12 OAKS 348-8600. LIVONIA - Beautiful four bedroom colonial. Just remodeled. Built in 1973.

Century 21 REAL ESTATE 125 EAST MAIN STREET NORTHVILLE, MICHIGAN 48167 349-3470. 44931 Byrne Drive (S. of 9 Mi. & W. of Sheldon Rd.)

Century 21 REAL ESTATE 43133 W. Seven Mile Rd. (at East Lake Shopping Center) Northville 349-1212. BRIGHTON FROM \$86,200

Century 21 SUBURBAN REALTORS Prestigious Northville Commons. Immaculate 4 bedroom colonial, beamed cathedral ceiling.

Real Estate One, INC. Real Estate training class starting soon. Call Carolyn Beyer, 348-6430 for details.

VACANT LAND - LIVONIA. Good investment - close to expressway. Possible rezoning to commercial. \$25,000. 348-6430

MICHIGAN'S LARGEST REAL ESTATE COMPANY. Northville 4 bedroom Colonial. Desirable Northville Commons. Mature landscaping with in-ground pool.

CAREER OPPORTUNITY Real Estate training class starting soon. Call Carolyn Beyer, 348-6430 for details.

NORTHVILLE. Best price in Country Price for this 3 bedroom Township backing to the woods. Fireplace in living room, formal dining room with wet bar.

WELCOME HOMES. Models Open Everyday 1-6 p.m. Oakland County Office (313) 674-1153

021 Houses FOWLERVILLE. Beautiful story home located in town. 4 bedrooms, 2 full baths.

022 Houses HAMBURG. Arrowhead Subdivision. Secluded wooded lot backing to state land.

023 Houses HIGHLAND. For sale by owner. Williamsburg Colonial in prestigious Arford area.

024 Houses NICHOLS REALTY INC. 41074 W. Seven Mile Rd., Northville 348-3044

025 Houses GENTRY REAL ESTATE 41074 W. Seven Mile Rd. Northville 348-3044

026 Houses BRITTON FROM \$86,200. Includes 1/2 acre lot, 3 bedrooms, 2 bath, basement, 2 car garage.

027 Houses ADLER MODEL HOMES. MODEL OPEN 12-6. MODEL CLOSED TUES. & THURS.

028 Houses BRIGHTON. New 4 bedroom Cape Cod, living room, dining room, family room, 2 car garage.

029 Houses BRIGHTON. New 4 bedroom Cape Cod, living room, dining room, family room, 2 car garage.

030 Houses BRIGHTON. New 4 bedroom Cape Cod, living room, dining room, family room, 2 car garage.

031 Houses BRIGHTON. New 4 bedroom Cape Cod, living room, dining room, family room, 2 car garage.

001 Absolutely Free 1971 NOVA. 1672 top pine trees. You dig. Easy access.

002 Absolutely Free 1 PAIR breeding rabbits, with cage. \$1327-2993

003 Absolutely Free 2 BARN cats, males, 6 months old.

004 Absolutely Free 1971 NOVA. 1672 top pine trees. You dig. Easy access.

010 Special Notices ADOPTION not abortion. Are you pregnant and unable to keep your child?

011 Special Notices FREE 12" TV, needs work. FREE 4 YEAR female Doberman.

012 Special Notices GOLDEN Retriever/Black and Tan puppy, 4 months.

013 Special Notices BRIGHTON. Lake privileges. Classy sub. Beautifully decorated, custom vinyl treatments.

014 Real Estate FOR SALE BRIGHTON. Lake privileges. Classy sub. Beautifully decorated, custom vinyl treatments.

015 Houses BRIGHTON. Lake privileges. Classy sub. Beautifully decorated, custom vinyl treatments.

016 Houses BRIGHTON. Lake privileges. Classy sub. Beautifully decorated, custom vinyl treatments.

017 Real Estate FOR SALE BRIGHTON. Lake privileges. Classy sub. Beautifully decorated, custom vinyl treatments.

018 Houses BRIGHTON. Lake privileges. Classy sub. Beautifully decorated, custom vinyl treatments.

019 Houses BRIGHTON. Lake privileges. Classy sub. Beautifully decorated, custom vinyl treatments.

020 Houses BRIGHTON. Lake privileges. Classy sub. Beautifully decorated, custom vinyl treatments.

021 Houses BRIGHTON. Lake privileges. Classy sub. Beautifully decorated, custom vinyl treatments.

022 Houses HAMBURG. Arrowhead Subdivision. Secluded wooded lot backing to state land.

023 Houses HIGHLAND. For sale by owner. Williamsburg Colonial in prestigious Arford area.

024 Houses NICHOLS REALTY INC. 41074 W. Seven Mile Rd., Northville 348-3044

025 Houses GENTRY REAL ESTATE 41074 W. Seven Mile Rd. Northville 348-3044

026 Houses BRITTON FROM \$86,200. Includes 1/2 acre lot, 3 bedrooms, 2 bath, basement, 2 car garage.

027 Houses ADLER MODEL HOMES. MODEL OPEN 12-6. MODEL CLOSED TUES. & THURS.

028 Houses BRIGHTON. New 4 bedroom Cape Cod, living room, dining room, family room, 2 car garage.

029 Houses BRIGHTON. New 4 bedroom Cape Cod, living room, dining room, family room, 2 car garage.

BRIGHTON - HOWELL area. Country Estates, 1822 W. Eight Mile Road. 3 bed, 2.5 bath. Hardwood floors. Large kitchen. 2 car garage. \$128,000. (313) 484-3833.

FOWLERVILLE - 1973 American, 3 bedrooms, 2.5 baths. Spacious living room. Wood floors. \$157,500. Call for appointment. (313) 484-3833.

HOWELL - Nice three bedroom two bath home on Lake Chemung. Perfectionist lot and a great location! Call for all seasons. \$66,900. (313) 227-2200.

PREVIEW PROPERTIES (313) 227-2200

HARDYMAN SPECIAL - partialy remodeled conventional home with 3 bedrooms, 2 1/2 baths, new gas furnace garage. \$50,000. (313) 484-3833.

J.R. Hayner - 438 N. Grand River, Brighton, Michigan (313) 227-5400

BRIGHTON SCHOOLS - All sports, lakefront, 6 bedrooms, 3 baths, \$176,900.

Sandra Baum - Office: 227-4600, Evenings: 227-3660

021 Duplexes

HIGHLAND LAKES, Northville - Two bedroom, one bath. Partially finished basement. Full finished kitchen, full bath, full basement. \$135,000. (313) 484-3833.

HIGHLAND GREENS, Northville - 1470 Festival, 3 bedrooms, 2 1/2 baths, stove, refrigerator, dishwasher. \$133,000. (313) 287-7246.

HIGHLAND GREENS, Northville - 1880 Patriot, 2 bedrooms, 2 baths, fireplace, wet bar, full finished basement. \$133,000. (313) 287-7246.

HIGHLAND GREENS, Northville - 1974 14x65 Champion, includes stove, kitchen appliances, ashed, central air. \$45,000. (313) 287-7246.

HIGHLAND GREENS, Northville - 1974 14x65 Champion, includes stove, kitchen appliances, ashed, central air. \$45,000. (313) 287-7246.

NEED Financing or Refinancing on a Mobile Home?

- Low Rates
- 10% down available
- Financial services available

477-1415

HOWELL - 1985 double 1216 sq. ft. 3 bedrooms, 2 baths, excellent location. Many extras. \$29,700. (313) 229-4000.

NORTHVILLE - Lexington Condos, 2 bedrooms, 2 baths, attached garage, 1st floor laundry, finished walk-out garage, 2 lavatories, full kitchen, utility room and large enclosed porch. By owner. \$100,000. (313) 484-3833.

HOWELL - Dramatic picture mobile home on large lot. 3 bedrooms, 2 full baths, full basement, garage, skylights, vaulted ceilings. \$149,500. (313) 484-3833.

HOWELL - Gorgeous 1980 gem. 3 bedrooms, 2 full baths, all appliances. \$33,900. (313) 229-4000.

HOWELL - Vacant 2 bedroom with new carpet throughout. Financing available. \$112,900. (313) 229-4000.

NORTHFIELD ESTATES - "For Over 15 Years"

DARLING MANUFACTURED HOMES - "For Over 15 Years"

NORTHFIELD ESTATES - Office: Site No. 843. (313) 484-3833

global - MOBILE HOMES INC.

NORTHFIELD ESTATES - Stock Model Clearance Sale 5 Stock Models Must Be Sold By November 27, 1987. Homes are set ready for immediate occupancy.

Choice of - Discounts of \$1000 to \$5000 or Pre-Paid Lot Rent.

Now taking orders for Phase III - Whitmore Lake Northville

Whitmore Lake - 855 W. 8 Mile Rd. \$62,700. 4.33 acre section.

Northville - 5822 W. 8 Mile Rd. \$62,700. 4.33 acre section.

Choice of - Discounts of \$1000 to \$5000 or Pre-Paid Lot Rent.

Now taking orders for Phase III - Whitmore Lake Northville

Whitmore Lake - 855 W. 8 Mile Rd. \$62,700. 4.33 acre section.

Northville - 5822 W. 8 Mile Rd. \$62,700. 4.33 acre section.

022 Lakefront Homes For Sale

025 Mobile Homes For Sale

026 Mobile Homes For Sale

031 Vacant Property For Sale

031 Houses For Rent

032 Apartments For Rent

034 Apartments For Rent

038 Foster Care

080 Office Space For Rent

101 Antiques

102 Auctions

104 Household Goods

105 Firewood And Coal

107 Miscellaneous

108 Miscellaneous

111 Farm Products

022 Lakefront Homes For Sale

025 Mobile Homes For Sale

026 Mobile Homes For Sale

031 Vacant Property For Sale

031 Houses For Rent

032 Apartments For Rent

034 Apartments For Rent

038 Foster Care

080 Office Space For Rent

101 Antiques

102 Auctions

104 Household Goods

105 Firewood And Coal

107 Miscellaneous

108 Miscellaneous

111 Farm Products

027 Farms, Acreage, For Sale

029 Lake Property For Sale

032 Industrial Commercial For Sale

033 Industrial Commercial For Sale

034 Industrial Commercial For Sale

035 Income Property For Sale

036 Industrial Commercial For Sale

037 Industrial Commercial For Sale

038 Industrial Commercial For Sale

039 Cemetery Lots For Sale

041 Vacant Property For Sale

042 Vacant Property For Sale

043 Vacant Property For Sale

044 Vacant Property For Sale

045 Vacant Property For Sale

046 Vacant Property For Sale

047 Vacant Property For Sale

048 Vacant Property For Sale

049 Vacant Property For Sale

050 Vacant Property For Sale

051 Houses For Rent

052 Apartments For Rent

054 Apartments For Rent

058 Foster Care

080 Office Space For Rent

101 Antiques

102 Auctions

104 Household Goods

105 Firewood And Coal

107 Miscellaneous

108 Miscellaneous

111 Farm Products

027 Farms, Acreage, For Sale

029 Lake Property For Sale

032 Industrial Commercial For Sale

033 Industrial Commercial For Sale

034 Industrial Commercial For Sale

035 Income Property For Sale

036 Industrial Commercial For Sale

037 Industrial Commercial For Sale

038 Industrial Commercial For Sale

039 Cemetery Lots For Sale

041 Vacant Property For Sale

042 Vacant Property For Sale

043 Vacant Property For Sale

044 Vacant Property For Sale

045 Vacant Property For Sale

046 Vacant Property For Sale

047 Vacant Property For Sale

048 Vacant Property For Sale

049 Vacant Property For Sale

050 Vacant Property For Sale

051 Houses For Rent

052 Apartments For Rent

054 Apartments For Rent

058 Foster Care

080 Office Space For Rent

101 Antiques

102 Auctions

104 Household Goods

105 Firewood And Coal

107 Miscellaneous

108 Miscellaneous

111 Farm Products

WHITMORE LAKE - 1 bedroom, non-drinker, 1 car. \$39,900. (313) 227-2200.

051 Houses For Rent

052 Apartments For Rent

054 Apartments For Rent

058 Foster Care

080 Office Space For Rent

101 Antiques

102 Auctions

104 Household Goods

105 Firewood And Coal

107 Miscellaneous

108 Miscellaneous

111 Farm Products

051 Houses For Rent

052 Apartments For Rent

054 Apartments For Rent

058 Foster Care

080 Office Space For Rent

101 Antiques

102 Auctions

104 Household Goods

105 Firewood And Coal

107 Miscellaneous

108 Miscellaneous

111 Farm Products

051 Houses For Rent

052 Apartments For Rent

054 Apartments For Rent

058 Foster Care

080 Office Space For Rent

101 Antiques

102 Auctions

104 Household Goods

105 Firewood And Coal

107 Miscellaneous

108 Miscellaneous

111 Farm Products

051 Houses For Rent

052 Apartments For Rent

054 Apartments For Rent

058 Foster Care

080 Office Space For Rent

101 Antiques

102 Auctions

104 Household Goods

105 Firewood And Coal

107 Miscellaneous

108 Miscellaneous

111 Farm Products

051 Houses For Rent

052 Apartments For Rent

054 Apartments For Rent

058 Foster Care

080 Office Space For Rent

101 Antiques

102 Auctions

104 Household Goods

105 Firewood And Coal

107 Miscellaneous

108 Miscellaneous

111 Farm Products

051 Houses For Rent

052 Apartments For Rent

054 Apartments For Rent

058 Foster Care

080 Office Space For Rent

101 Antiques

102 Auctions

104 Household Goods

105 Firewood And Coal

107 Miscellaneous

108 Miscellaneous

111 Farm Products

051 Houses For Rent

052 Apartments For Rent

054 Apartments For Rent

058 Foster Care

080 Office Space For Rent

101 Antiques

102 Auctions

104 Household Goods

105 Firewood And Coal

107 Miscellaneous

108 Miscellaneous

111 Farm Products

051 Houses For Rent

052 Apartments For Rent

054 Apartments For Rent

058 Foster Care

080 Office Space For Rent

101 Antiques

102 Auctions

104 Household Goods

105 Firewood And Coal

107 Miscellaneous

108 Miscellaneous

111 Farm Products

051 Houses For Rent

052 Apartments For Rent

054 Apartments For Rent

058 Foster Care

080 Office Space For Rent

101 Antiques

102 Auctions

104 Household Goods

105 Firewood And Coal

107 Miscellaneous

108 Miscellaneous

111 Farm Products

051 Houses For Rent

052 Apartments For Rent

054 Apartments For Rent

058 Foster Care

080 Office Space For Rent

101 Antiques

102 Auctions

104 Household Goods

105 Firewood And Coal

107 Miscellaneous

108 Miscellaneous

111 Farm Products

051 Houses For Rent

052 Apartments For Rent

054 Apartments For Rent

058 Foster Care

080 Office Space For Rent

101 Antiques

102 Auctions

104 Household Goods

105 Firewood And Coal

107 Miscellaneous

108 Miscellaneous

111 Farm Products

051 Houses For Rent

052 Apartments For Rent

054 Apartments For Rent

058 Foster Care

080 Office Space For Rent

101 Antiques

102 Auctions

104 Household Goods

105 Firewood And Coal

107 Miscellaneous

108 Miscellaneous

111 Farm Products

051 Houses For Rent

052 Apartments For Rent

054 Apartments For Rent

058 Foster Care

080 Office Space For Rent

101 Antiques

102 Auctions

104 Household Goods

105 Firewood And Coal

107 Miscellaneous

108 Miscellaneous

111 Farm Products

051 Houses For Rent

052 Apartments For Rent

054 Apartments For Rent

058 Foster Care

080 Office Space For Rent

101 Antiques

102 Auctions

104 Household Goods

105 Firewood And Coal

107 Miscellaneous

108 Miscellaneous

111 Farm Products

051 Houses For Rent

052 Apartments For Rent

054 Apartments For Rent

058 Foster Care

080 Office Space For Rent

101 Antiques

102 Auctions

104 Household Goods

105 Firewood And Coal

107 Miscellaneous

108 Miscellaneous

111 Farm Products

051 Houses For Rent

052 Apartments For Rent

054 Apartments For Rent

058 Foster Care

080 Office Space For Rent

101 Antiques

102 Auctions

104 Household Goods

105 Firewood And Coal

107 Miscellaneous

108 Miscellaneous

111 Farm Products

051 Houses For Rent

052 Apartments For Rent

054 Apartments For Rent

058 Foster Care

080 Office Space For Rent

101 Antiques

102 Auctions

104 Household Goods

105 Firewood And Coal

107 Miscellaneous

108 Miscellaneous

111 Farm Products

051 Houses For Rent

052 Apartments For Rent

054 Apartments For Rent

058 Foster Care

080 Office Space For Rent

101 Antiques

102 Auctions

104 Household Goods

105 Firewood And Coal

107 Miscellaneous

108 Miscellaneous

111 Farm Products

051 Houses For Rent

052 Apartments For Rent

054 Apartments For Rent

058 Foster Care

080 Office Space For Rent

101 Antiques

102 Auctions

104 Household Goods

105 Firewood And Coal

107 Miscellaneous

108 Miscellaneous

111 Farm Products

051 Houses For Rent

052 Apartments For Rent

054 Apartments For Rent

058 Foster Care

080 Office Space For Rent

101 Antiques

102 Auctions

104 Household Goods

105 Firewood And Coal

107 Miscellaneous

108 Miscellaneous

111 Farm Products

051 Houses For Rent

052 Apartments For Rent

054 Apartments For Rent

058 Foster Care

080 Office Space For Rent

101 Antiques

102 Auctions

104 Household Goods

105 Firewood And Coal

107 Miscellaneous

108 Miscellaneous

111 Farm Products

051 Houses For Rent

052 Apartments For Rent

054 Apartments For Rent

058 Foster Care

080 Office Space For Rent

101 Antiques

102 Auctions

104 Household Goods

105 Firewood And Coal

107 Miscellaneous

108 Miscellaneous

111 Farm Products

051 Houses For Rent

052 Apartments For Rent

054 Apartments For Rent

058 Foster Care

080 Office Space For Rent

101 Antiques

102 Auctions

104 Household Goods

105 Firewood And Coal

107 Miscellaneous

108 Miscellaneous

111 Farm Products

051 Houses For Rent

052 Apartments For Rent

054 Apartments For Rent

058 Foster Care

080 Office Space For Rent

101 Antiques

102 Auctions

104 Household Goods

105 Firewood And Coal

107 Miscellaneous

108 Miscellaneous

111 Farm Products

110 Wood Stoves
WOOD and coal burning stove, approximately 75 years old. Mfg. from \$250 or best. (313)285-6268.

151 Horses & Pets
BASSSET Hound female, 10 months old. Beautiful, well-spaced. Shows. Tr. (517)223-3500.

152 Horses & Pets
ARABIAN mares and geldings. 1000. (313)887-7958.

153 Horses & Pets
HORSE FENCING, 1/8, 3/4, and/or 1/4. Oak, rough cut, white. \$4.95. (313)887-7958.

154 Pet Supplies
FISH tank, 20 gallons long with stand. Fish and all other accessories. \$85. (313)887-7958.

160 Clerical
SECRETARY for Livingston County Prosecutor's office. Good typing skills as well as excellent secretarial skills. (313)887-7958.

DATA ENTRY
55-6/1. Temporary to start Farmington Hills, Novi, West Bloomfield. (414)872-7272.

161 Day-care Babysitting
BABYSITTING done in Howell, Litchfield, and Farmington Hills. (313)887-7958.

162 Medical
DENTAL Receptionist/Bookkeeper. Must be computer literate. Will train. Send resume to 41E. (313)887-7958.

163 Nursing Homes
HOUSEKEEPER, part-time and full-time. Apply: West Winds Nursing Home. (313)887-7958.

164 Restaurant
EARN tips \$450 in hour. Waitresses and waiters. Also positions available for cooks and bus persons. (313)887-7958.

151 Household Pets
13 GALLON glass terrarium complete with fish. \$50. (313)229-9877.

152 Horses & Pets
AKC English Springer spaniel puppies. Beautiful pets. (313)229-9877.

153 Farm Animals
1800 AKA gelding, chestnut, great English horse. (313)229-9877.

154 Pet Supplies
Are you innovative, motivated and sales oriented? Complete training and offers a super opportunity to someone who possesses the following qualifications: (313)229-9877.

REGISTRATION
McPherson Community Health Center is a 136-bed acute care hospital. The Nursing Department needs the needs of our professional nursing care at this time. (313)229-9877.

REGISTRATION
Are you innovative, motivated and sales oriented? Complete training and offers a super opportunity to someone who possesses the following qualifications: (313)229-9877.

REGISTRATION
Are you innovative, motivated and sales oriented? Complete training and offers a super opportunity to someone who possesses the following qualifications: (313)229-9877.

REGISTRATION
Are you innovative, motivated and sales oriented? Complete training and offers a super opportunity to someone who possesses the following qualifications: (313)229-9877.

ALUMINUM Seamless awning, 20 years experience. State licensed, insured. (313)229-9877.

BRICK, BLOCK, Cement Building & Remodeling
QUALITY building at the lowest prices. Additions, garages, repairs, roofing, siding, cement and tile. (313)229-9877.

BRICK, BLOCK, Cement Building & Remodeling
QUALITY building at the lowest prices. Additions, garages, repairs, roofing, siding, cement and tile. (313)229-9877.

BRICK, BLOCK, Cement Building & Remodeling
QUALITY building at the lowest prices. Additions, garages, repairs, roofing, siding, cement and tile. (313)229-9877.

BRICK, BLOCK, Cement Building & Remodeling
QUALITY building at the lowest prices. Additions, garages, repairs, roofing, siding, cement and tile. (313)229-9877.

BRICK, BLOCK, Cement Building & Remodeling
QUALITY building at the lowest prices. Additions, garages, repairs, roofing, siding, cement and tile. (313)229-9877.

BRICK, BLOCK, Cement Building & Remodeling
QUALITY building at the lowest prices. Additions, garages, repairs, roofing, siding, cement and tile. (313)229-9877.

BRICK, BLOCK, Cement Building & Remodeling
QUALITY building at the lowest prices. Additions, garages, repairs, roofing, siding, cement and tile. (313)229-9877.

BRICK, BLOCK, Cement Building & Remodeling
QUALITY building at the lowest prices. Additions, garages, repairs, roofing, siding, cement and tile. (313)229-9877.

BRICK, BLOCK, Cement Building & Remodeling
QUALITY building at the lowest prices. Additions, garages, repairs, roofing, siding, cement and tile. (313)229-9877.

BRICK, BLOCK, Cement Building & Remodeling
QUALITY building at the lowest prices. Additions, garages, repairs, roofing, siding, cement and tile. (313)229-9877.

BRICK, BLOCK, Cement Building & Remodeling
QUALITY building at the lowest prices. Additions, garages, repairs, roofing, siding, cement and tile. (313)229-9877.

BRICK, BLOCK, Cement Building & Remodeling
QUALITY building at the lowest prices. Additions, garages, repairs, roofing, siding, cement and tile. (313)229-9877.

BRICK, BLOCK, Cement Building & Remodeling
QUALITY building at the lowest prices. Additions, garages, repairs, roofing, siding, cement and tile. (313)229-9877.

BRICK, BLOCK, Cement Building & Remodeling
QUALITY building at the lowest prices. Additions, garages, repairs, roofing, siding, cement and tile. (313)229-9877.

BRICK, BLOCK, Cement Building & Remodeling
QUALITY building at the lowest prices. Additions, garages, repairs, roofing, siding, cement and tile. (313)229-9877.

BRICK, BLOCK, Cement Building & Remodeling
QUALITY building at the lowest prices. Additions, garages, repairs, roofing, siding, cement and tile. (313)229-9877.

184 Restaurant
Little Caesar's is looking for motivated managers...
185 Help Wanted General
Alpha Technology Corp.
186 Help Wanted General
ATTENTION: Laid Off Workers...

187 Business Opportunities
Country Store, Beer, wine, groceries...
188 Instructional Schools
201 Motorcycles
189 Trucks
190 Auto Parts & Services

191 Trucks
192 Trucks
193 Trucks
194 Trucks
195 Trucks
196 Trucks
197 Trucks
198 Trucks
199 Trucks

200 Trucks
201 Trucks
202 Trucks
203 Trucks
204 Trucks
205 Trucks
206 Trucks
207 Trucks
208 Trucks

209 Trucks
210 Trucks
211 Trucks
212 Trucks
213 Trucks
214 Trucks
215 Trucks
216 Trucks
217 Trucks

218 Trucks
219 Trucks
220 Trucks
221 Trucks
222 Trucks
223 Trucks
224 Trucks
225 Trucks
226 Trucks

227 Trucks
228 Trucks
229 Trucks
230 Trucks
231 Trucks
232 Trucks
233 Trucks
234 Trucks
235 Trucks

165 Help Wanted General
DANCE TEACHERS
Outgoing individuals for jazz, tap, tumbling and ballroom classes...

166 Help Wanted General
EXPANDING MULTI-LEVEL GENERAL laborers needed for machine and maintenance work...

167 Help Wanted General
MACHINE OPERATORS
Plastic molding machine operators needed for all shifts...

168 Help Wanted General
MANAGERS IN TRAINING
10 new management positions needed for Domino's Pizza of Livingston County...

169 Help Wanted General
MACHINE OPERATORS
Plastic molding machine operators needed for all shifts...

170 Help Wanted General
MANAGERS IN TRAINING
10 new management positions needed for Domino's Pizza of Livingston County...

171 Help Wanted General
MACHINE OPERATORS
Plastic molding machine operators needed for all shifts...

172 Help Wanted General
DATA ENTRY
Experienced data entry operators needed for long term contract...

173 Help Wanted General
KELLY SERVICES
DELIVERY PERSONS: Full or part-time, days, nights, up to 24 hours...

174 Help Wanted General
CNC OPERATORS/SET-UP
Full or part-time, for Okuma 4 axis lathes and machining centers...

175 Help Wanted General
FACTORY WORKERS
Machine operators & many other jobs. Days 44-50 hrs. to start...

176 Help Wanted General
MACHINE OPERATORS
Mechanically inclined person for maintenance in running tool room equipment...

177 Help Wanted General
MACHINE OPERATORS
Mechanically inclined person for maintenance in running tool room equipment...

178 Help Wanted General
MACHINE OPERATORS
Mechanically inclined person for maintenance in running tool room equipment...

179 Help Wanted General
MACHINE OPERATORS
Mechanically inclined person for maintenance in running tool room equipment...

180 Help Wanted General
MACHINE OPERATORS
Mechanically inclined person for maintenance in running tool room equipment...

181 Help Wanted General
MACHINE OPERATORS
Mechanically inclined person for maintenance in running tool room equipment...

182 Help Wanted General
MACHINE OPERATORS
Mechanically inclined person for maintenance in running tool room equipment...

183 Help Wanted General
MACHINE OPERATORS
Mechanically inclined person for maintenance in running tool room equipment...

184 Help Wanted General
MACHINE OPERATORS
Mechanically inclined person for maintenance in running tool room equipment...

185 Help Wanted General
MACHINE OPERATORS
Mechanically inclined person for maintenance in running tool room equipment...

186 Help Wanted General
MACHINE OPERATORS
Mechanically inclined person for maintenance in running tool room equipment...

187 Help Wanted General
MACHINE OPERATORS
Mechanically inclined person for maintenance in running tool room equipment...

188 Help Wanted General
MACHINE OPERATORS
Mechanically inclined person for maintenance in running tool room equipment...

189 Help Wanted General
MACHINE OPERATORS
Mechanically inclined person for maintenance in running tool room equipment...

190 Help Wanted General
MACHINE OPERATORS
Mechanically inclined person for maintenance in running tool room equipment...

191 Help Wanted General
MACHINE OPERATORS
Mechanically inclined person for maintenance in running tool room equipment...

192 Help Wanted General
MACHINE OPERATORS
Mechanically inclined person for maintenance in running tool room equipment...

193 Help Wanted General
MACHINE OPERATORS
Mechanically inclined person for maintenance in running tool room equipment...

194 Help Wanted General
MACHINE OPERATORS
Mechanically inclined person for maintenance in running tool room equipment...

195 Help Wanted General
MACHINE OPERATORS
Mechanically inclined person for maintenance in running tool room equipment...

196 Help Wanted General
MACHINE OPERATORS
Mechanically inclined person for maintenance in running tool room equipment...

197 Help Wanted General
MACHINE OPERATORS
Mechanically inclined person for maintenance in running tool room equipment...

198 Help Wanted General
MACHINE OPERATORS
Mechanically inclined person for maintenance in running tool room equipment...

199 Help Wanted General
MACHINE OPERATORS
Mechanically inclined person for maintenance in running tool room equipment...

200 Help Wanted General
MACHINE OPERATORS
Mechanically inclined person for maintenance in running tool room equipment...

201 Help Wanted General
MACHINE OPERATORS
Mechanically inclined person for maintenance in running tool room equipment...

202 Help Wanted General
MACHINE OPERATORS
Mechanically inclined person for maintenance in running tool room equipment...

203 Help Wanted General
MACHINE OPERATORS
Mechanically inclined person for maintenance in running tool room equipment...

204 Help Wanted General
MACHINE OPERATORS
Mechanically inclined person for maintenance in running tool room equipment...

205 Help Wanted General
MACHINE OPERATORS
Mechanically inclined person for maintenance in running tool room equipment...

206 Help Wanted General
MACHINE OPERATORS
Mechanically inclined person for maintenance in running tool room equipment...

207 Help Wanted General
MACHINE OPERATORS
Mechanically inclined person for maintenance in running tool room equipment...

208 Help Wanted General
MACHINE OPERATORS
Mechanically inclined person for maintenance in running tool room equipment...

209 Help Wanted General
MACHINE OPERATORS
Mechanically inclined person for maintenance in running tool room equipment...

210 Help Wanted General
MACHINE OPERATORS
Mechanically inclined person for maintenance in running tool room equipment...

211 Help Wanted General
MACHINE OPERATORS
Mechanically inclined person for maintenance in running tool room equipment...

212 Help Wanted General
MACHINE OPERATORS
Mechanically inclined person for maintenance in running tool room equipment...

213 Help Wanted General
MACHINE OPERATORS
Mechanically inclined person for maintenance in running tool room equipment...

214 Help Wanted General
MACHINE OPERATORS
Mechanically inclined person for maintenance in running tool room equipment...

215 Help Wanted General
MACHINE OPERATORS
Mechanically inclined person for maintenance in running tool room equipment...

216 Help Wanted General
MACHINE OPERATORS
Mechanically inclined person for maintenance in running tool room equipment...

217 Help Wanted General
MACHINE OPERATORS
Mechanically inclined person for maintenance in running tool room equipment...

218 Help Wanted General
MACHINE OPERATORS
Mechanically inclined person for maintenance in running tool room equipment...

219 Help Wanted General
MACHINE OPERATORS
Mechanically inclined person for maintenance in running tool room equipment...

220 Help Wanted General
MACHINE OPERATORS
Mechanically inclined person for maintenance in running tool room equipment...

221 Help Wanted General
MACHINE OPERATORS
Mechanically inclined person for maintenance in running tool room equipment...

222 Help Wanted General
MACHINE OPERATORS
Mechanically inclined person for maintenance in running tool room equipment...

223 Help Wanted General
MACHINE OPERATORS
Mechanically inclined person for maintenance in running tool room equipment...

224 Help Wanted General
MACHINE OPERATORS
Mechanically inclined person for maintenance in running tool room equipment...

225 Help Wanted General
MACHINE OPERATORS
Mechanically inclined person for maintenance in running tool room equipment...

226 Help Wanted General
MACHINE OPERATORS
Mechanically inclined person for maintenance in running tool room equipment...

227 Help Wanted General
MACHINE OPERATORS
Mechanically inclined person for maintenance in running tool room equipment...

228 Help Wanted General
MACHINE OPERATORS
Mechanically inclined person for maintenance in running tool room equipment...

229 Help Wanted General
MACHINE OPERATORS
Mechanically inclined person for maintenance in running tool room equipment...

230 Help Wanted General
MACHINE OPERATORS
Mechanically inclined person for maintenance in running tool room equipment...

231 Help Wanted General
MACHINE OPERATORS
Mechanically inclined person for maintenance in running tool room equipment...

232 Help Wanted General
MACHINE OPERATORS
Mechanically inclined person for maintenance in running tool room equipment...

233 Help Wanted General
MACHINE OPERATORS
Mechanically inclined person for maintenance in running tool room equipment...

234 Help Wanted General
MACHINE OPERATORS
Mechanically inclined person for maintenance in running tool room equipment...

235 Help Wanted General
MACHINE OPERATORS
Mechanically inclined person for maintenance in running tool room equipment...

236 Help Wanted General
MACHINE OPERATORS
Mechanically inclined person for maintenance in running tool room equipment...

237 Help Wanted General
MACHINE OPERATORS
Mechanically inclined person for maintenance in running tool room equipment...

238 Help Wanted General
MACHINE OPERATORS
Mechanically inclined person for maintenance in running tool room equipment...

239 Help Wanted General
MACHINE OPERATORS
Mechanically inclined person for maintenance in running tool room equipment...

240 Help Wanted General
MACHINE OPERATORS
Mechanically inclined person for maintenance in running tool room equipment...

241 Help Wanted General
MACHINE OPERATORS
Mechanically inclined person for maintenance in running tool room equipment...

WALDECKER • WALDECKER • WALDECKER • WALDECKER • WALDECKER

STOP

LOW PRICE ZONE TRUCKS

- '86 GMC S-15 4 X 4 \$8995
13,000 one owner miles. aluminum wheels, stereo, sharp
- '85 S-10 Blazer \$11,495
Taboe pkg., loaded with options, low miles, two-tone paint
- '87 S-10 Blazer \$14,900
Taboe pkg., lots of equipment, aluminum wheels, like new
- '84 Suburban Silverado \$11,995
37,000 miles. 6.2 diesel, running boards-trailer towing pkg.
- '86 Chevy Silverado Pick-Ups \$10,995
Two to choose from, V-8's, loaded, low miles, your choice
- '86 Chevy 4 X 4 Pick-Up \$12,595
Scottsdale pkg., ready for winter work or play - this truck's a gem
- '85 Ford F-350 XL Dually \$12,900
460 V-8, tilt, cruise, air, stereo, p. windows, p. locks, chrome wheels
- '86 Ford F 250 XLT Lariat Pick-Up \$12,900
6.9 Diesel, loaded, lighted running boards, bed liner, you have to see it!
- '85 GMC 4 X 4 Pick-Up \$11,495
High Sierra, tilt, cruise, air, stereo, p. windows & locks, fiberglass top - extra clean
- '85 GMC Sierra Classic Pick-Up \$9995
20,000 easy miles, loaded with options - this truck's been pampered
- '85 Ford F 150 Pick-Up \$5495
6 cyl, 4 spd, chrome wheels, bed liner, priced to sell
- '86 Chevy Conversion Van \$12,995
Everything you need to travel in comfort and style. Was \$13,995 - Reduced
- '77 Shasta Mini Motor Home \$9995
22 foot, fully self contained. Everything works. Super clean - one owner
- '85 Chevy Suburban \$13,900
Factory evaluation vehicle. Silverado pkg, loaded with options, 6.2 diesel, 11,000 original miles
- '87 K-5 Blazer \$15,900
V-8, loaded, two-tone, running boards, 13,000 miles, bargain priced

QUALITY USED CARS

- '87 Chevy Corsica \$8995
4 dr., automatic, air, stereo & more
- '87 Chevy Spectrum \$6995
Automatic, air, only 5500 miles. SAVE thousands
- '84 Grand Prix \$5995
One owner, nice equipment, won't be here long
- '87 Charger \$6995
One owner, black with grey cloth, am-fm stereo, 4 cyl, 4 spd, get mileage & looks too
- '86 Fiero \$7950
Loaded, 5 spd, one owner. Save A Bunch
- '83 Celebrity \$4995
4 dr, auto, ps, pb, air, stereo, low miles

Hours: M & Th 9 to 9
Tues., Wed. & Fri. 9 to 6
Saturday 10 to 3

WALDECKER PONTIAC-BUICK
7885 W. GRAND RIVER • BRIGHTON MI
227-1761

LOW PRICE ZONE HEADQUARTERS!

WALDECKER • WALDECKER • WALDECKER • WALDECKER • WALDECKER

SPIKER LARGEST VOLUME FORD-MERCURY DEALERSHIP

IN SOUTHEASTERN MICHIGAN FOR 20 CONTINUOUS YEARS

SUPER MARKET SAVINGS

200 Brand New **88-87 Ford - Mercury Ford - Trucks**

\$500⁰⁰ CASH BACK

On Selected Models Ford Motor Employees A & Z Plans Are Eligible. See Spike For Details

Immediate Delivery

BUY or LEASE FORD • MERCURY FORD TRUCKS

ORDER YOURS TODAY A, B & Z PLANS WELCOME

SELLING FORDS AND MERCURYS SINCE 1950 BRING US YOUR BEST DEAL... WE'LL MAKE IT BETTER

SPIKER **FORD MERCURY**

130 S. Milford Road, Milford 684-1715 or 963-6587

OPEN Monday & Thursday 'til 9 Tuesday, Wednesday, Friday 'til 6

Home of the Nearest Appraiser

239 Antique Cars 240 Automobiles 240 Automobiles

1984 CHEVROLET '76 pickup. Delux cab, stock, very good condition. (57)546-6279

1986 MUSTANG Coupe. 289-cv engine. Automatic transmission, rebuilt. New brakes, all original. \$1,000. (313)227-3584 after 6 pm.

1976 BUICK LeSabre. V-6 two door custom. 70,000 miles. air, etc. Very clean. \$1,800. (313)343-1619

1978 CADILLAC Coupe de Ville. New tires. Very clean. Runs good. (57)546-6532

1978 MONTE Carlo. Runs well. Good tires. \$1,400. (313)250-0793 after 6 pm.

1978 OLDS Cutlass Supreme. 60,000 miles. No rust. \$2,995. (313)250-0793 after 6 pm.

1978 THUNDERBIRD. 45,000 miles. Nice car. \$1,700. (313)231-2304

1978 Thunderbird. Very good condition in and out. No rust. Straight car. Ready to go. \$2,000. (313)227-108

1978 CADILLAC Coupe DeVille. Excellent condition. Loaded. \$3,600. (313)427-5438

1979 Lincoln Continental. 1 owner. 10,000 miles. (57)546-1353 ask for Joe.

1979 LTD. Good condition. \$2,500. (977)963-3505

1979 MONTE CARLO. Clear low miles. \$1,350 or best. (313)227-8545

1979 PONTAC Bonneville. 4 door. New tires. Cruise control. One owner. \$1,750. (313)227-8545

1979 FORD Ranger. Loaded. \$1,100 or best. (313)229-6528

1979 FORD. Loaded. Must sell. \$1,500 or best. (57)546-4600 days. (57)546-4721

1980 AMC Concord wagon. 70,000 miles. am/fm, tilt, air. Good condition. \$1,300. (313)343-1957

1980 BUICK Skylark. 2 door. Light beige, automatic. Call (313)231-1624

1980 MERCURY Stationwagon. All options. Good condition. \$1,800. (313)832-7635

1980 MUSTANG. 4 cylinder. 4 speed. Very dependable. \$1,500 or best. (313)832-7635

1981 2 DOOR Rabbit. Excellent condition. New clutch, newer tires, 5 speed. am/fm cassette. 61,000 miles. \$1,600. (313)832-9426

1981 AMC Eagle. Four wheel drive. spotless condition. 55,000 miles. (313)343-4869

1981 DODGE Omni 024 from Florida. Am/fm radio, 4 cylinder, 4 speed, extra clean. \$1,550. (57)722-3539 after 6 p.m.

1981 OLDS Cutlass. 4 door, automatic, air, power steering, power brakes, vinyl top, cruise control, one owner. \$2,700. (313)343-3555

1981 PLYMOUTH TCG. Good, dependable car. New tires. Sunroof, am/fm stereo. \$1,100. (313)832-7660

1981 TOYOTA TerCel. SRS. 60,000 miles. (57)546-3321

1982 COUGAR GS wagon. Air. 79,000 miles. \$2,500. (313)327-8242

1982 DODGE 400 LS. Loaded with most options. 80,000 miles. Good condition. \$1,100 or best. (313)887-3674 evenings.

FARMINGTON HILLS
CHRYSLER • Plymouth

SELECT LOW MILEAGE USED CARS AND TRADE-INS

'81 CHRYSLER LEBARON 4 door, low miles, excellent transportation. \$2995	'85 DODGE 600 2 door, turbo, triple black, loaded. \$10,500	'87 CHRYSLER LEBARON COUPE 4 door, loaded, low miles. \$9995
'83 CHRYSLER LEBARON 2 door, very low miles, all options, must see. \$6999	'86 CHRYSLER LASER Silver, automatic, air, 16,000 miles, extra sharp. \$9999	'88 FIFTH AVENUE Silver, leather and loaded. \$9999
'84 PONTIAC BONNEVILLE 2 tone blue like new. \$4995	'85 CHRYSLER LEBARON 4 door, 1 owner, extra low miles, very clean. \$4444	'84 BUICK CENTURY 4 door, maroon, V-6, 22,000 miles, must see.
'85 MERCURY MARQUIS BROUGHTON Fully loaded! 23,000 miles. \$6995	'87 DODGE OMNI 4 door, air, automatic, power steering and brakes, color AM-FM stereo, low miles, priced to sell.	

MANY FINE USED CARS TO CHOOSE FROM ON THE SPOT FINANCING

Grand River and Middlebelt • Farmington Hills
531-8200 • 476-7900

Who you gonna Call.... **229-4100**

PRICE BUSTER OF THE WEEK

'84 CHEVY CAVALIER WAGON Automatic air \$3295

It's located on Grand River next to Anthony's

85 Dodge Mini Caravan One owner, auto, air, p, s, low miles \$8895	85 Plymouth Voyager Auto, air, 7 passenger \$8595
83 Plymouth Reliant Station Wagon Auto, air, woodgrain \$3995	87 Chevy Nova Auto, air, on-ly 12,000 miles \$7995
'87 Chevy Conversion Van T.V. power windows and locks LOADED! \$AVE \$5495	'85 Chrysler LeBaron Turbo While, All The Toys! \$4995
We Buy Clean Used Cars! \$3195	85 Mercury Lynx \$3195
84 Ford Tempo GL \$2495	'83 Ford Mustang GT Red and Ready \$4595
87 Dodge Dakota Loaded! Duratiner \$9995	'84 Olds Delta Royale 2 dr., loaded \$4395
'84 Ford Mustang LX Auto, air, ps, pb, cruise, tilt \$4595	'84 Chrysler New Yorker Front wheel drive, low miles, new, one owner \$5995

BRIGHTON CHRYSLER PLYMOUTH DODGE
9827 E. Grand River, Brighton 229-4100

BRIGHTON CHRYSLER PLYMOUTH DODGE
9827 E. Grand River • 229-4100
"Home of the Price Busters"

240 Automobiles 240 Automobiles 240 Automobiles 240 Automobiles

1982 FORD Escort. 4 speed, am/fm stereo cassette, new front brakes. \$1,250. (313)634-7882

1982 FORD Crown Victoria. Full power, automatic with overdrive. Looks like new. \$4,400. Call between 5 p.m. and 10 p.m. (313)426-3548

1982 PLYMOUTH Reliant SE sedan 4 door. Roofruster. Asking \$2,200. Call (57)546-4543 after 5 p.m.

1982 ZEPHYR Good condition. 4 speed - \$1,200. Call after 6 p.m. (313)624-4452

1983 ALLIANCE Automatic. 2 door. 41,000 miles. \$2,700 or best. (313)227-9539 after 5:30 p.m.

1983 CADILLAC Brougham. well maintained. Loaded. asking \$5,000. (313)229-6591

1983 DODGE Charger. 2.2L 5 speed, power steering and brakes. JVC stereo, very good condition. \$2,600. (313)437-3088

1983 ESCORT: Excellent condition. All new tires. Call (313)437-071.

1983 FORD LTD station wagon. air, auto, \$2,500 or best. (313)229-6278

1983 FORD Escort wagon. 5 speed, cruise, am/fm radio. \$1,150 or best offer. (57)548-2250

1983 RENAULT Fuego Turbo. Low mileage, good condition. \$3,800. (313)227-7426

\$9995

Have You Driven A Chevy Truck Lately???

Chevy 1/2 Ton Pick Up
4.3, V-6 engine, 5 spd., engine, gauges, body side moldings, step bumper, cigarette lighter, tinted glass. Stock No. 8-513

Plus tax and license

Mr. Goodwrench
GM QUALITY SERVICE PARTS

Mitchell
Chevrolet-Oldsmobile

307 W. Grand River • Fowlerville • 517-223-9144

BUY WITH CONFIDENCE

INSTANT FINANCING

FACTORY WARRANTIES ARE STILL IN EFFECT ON THESE CARS

NO MONEY DOWN

1987 Tempo
4 dr's, auto, air, stereo, 4 to choose from only **\$7900**

1985 T-Bird Turbo Coupe
Loaded, moon roof only **\$8900**

1985 Merc Grand Marq LS
4 dr, full power, velor only **\$9800**

1986 Merc Colony Park Sta-Wgn
Full power, LS pkg, wood grain, two to choose from, only **\$9900**

1987 Taurus GL
Air, auto, full power only **\$10,400**

1987 T-Bird's
V-6, auto, air, p. windows, p. seats, cruise, tilt only **\$10,900**

1986 Ford Crown Vic
4 dr, loaded only **\$11,400**

1986 Merc Grand Marq LS
4 dr, loaded, 19,000 miles only **\$11,600**

1985 Linc Cont
Designer series only **\$12,900**

1986 Cadillac Eldorado Biaritz
Every option inc., moon roof only **\$14,800**

1987 Chev Corvette Convertible
Every option only **\$26,900**

1986 F-150
6 cyl, 4 spd, stereo only **\$7400**

1986 Ford Aerostar XLT Wgn
Loaded only **\$11,700**

1987 Aerostar's
XLT package, 3 to choose from starting at only **\$13,600**

1987 Ford Club-Wgn
8 pass, air, stereo, tilt, cruise only **\$12,800**

1987 Ford Club-Wgn E-250
12 pass, loaded only **\$13,200**

HUGE SAVINGS ON DEMOS

Many More Used Cars & Trucks To Choose From
* No money down with approved credit

We're New We're Competitive We're Driving Into The Future And... We're Out To Win You Over To Our Chevrolet Cars & Trucks

WE ARE **CHAMPION CHEVROLET**

1983 SPECTRUM
2 dr., hatchback, recline bucket seats, carpet, rear & side window defrosters-front wheel drive, steel radial tires, room for four adults to stretch out! And much more

10 In Stock

MPG 41

Plus A Few 1987 Spectrum With Up To 2000⁰⁰ Savings

Best Truck Buys

New '87 CARGO VAN No. 7-1213

1988 1/2 Ton Demo Pick-Up Free Bed Liner No. 8-1058

New 1987 Hi Cube Van No. 7115

350-V-8, auto, full gauges, tinted glass was \$3,246 Now Only \$10,566*	A/C, buckets, am-fm, rally wheels, tinted glass, 350 V-8, loaded was \$15,192 Now Only \$12,728*	14 ft., aluminum box, roll up door, auto, A/C, 350 V-8 was \$19,146 Now Only \$15,559*
---	--	--

WE NEED CLEAN USED CARS! TOP \$\$ PAID

1986 NOVA \$7195 ⁰⁰	1987 CELEBRITY EURO SPORT \$9872 ⁰⁰	ECONO \$1795 ⁰⁰	1985 S-10 \$1995 ⁰⁰	NICE \$12,973 ⁰⁰
auto, am-fm	1984 CAVALIER Great Shape	1985 S-10 Extended Cab X-tra Clean	1985 GMC CONVERSION VAN	1 Owner - Loaded

* Plus dest. and any optional or dealer added equipment
** Payment based on GMAC approved credit for buyer choose financing at 11% A.P.R.

CHAMPION CHEVROLET
FORMERLY GARY UNDERWOOD CHEVROLET

Parts Dept. Now Open Saturday 10 am-2 pm

603 W. Grand River, Downtown Brighton.
313-229-8800

HILLTOP FORD
Livingston Counties No. 1. Used Car Dealer
(517)546-2250 AT THE TOP OF THE HILL Howell

A Car Or Truck For Every Need Check With US

Save 1987 DEMO SALE PRICES SLASHED
Cutlass Ciera & Supremes & Delta 88's

1987 Bonneville LE \$14,500
4 Dr., 2,000 Miles

1987 Ford Tempo GL Sport \$7,495

1987 Cadillac Sedan Deville \$18,900
10,000 Miles

1986 Olds Ciera Brougham \$8,995
4 Dr.

1986 Olds Cutlass \$9,295
2 Dr.

1986 Olds Ciera Wagon \$9,695
13,000 Miles

1986 Olds Firenza Wagon \$6,995

1986 Honda Wagon \$7,495

1986 Buick Skyhawk \$7,995

1985 Cadillac Sedan Deville \$8,995
4 Dr.

1985 Monte Carlo \$7,995

1985 Celebrity \$6,995
4 Dr.

1985 Buick Sommerset \$7,495
Auto. A/C, 20,000 miles

1985 Olds Custom Cruiser \$7,495

1985 Olds 88 \$8,995
4 Dr.

1985 Tornado \$10,400
Last of Big Ones

1984 Chevettte \$2,995
4 Dr., Auto

Winter Special
1982 Pontiac Phoenix \$2,995
4 Dr.

1984 Buick Century \$6,995
4 Dr.

1984 Ford T-Bird \$6,995

1984 Pontiac Trans Am \$8,995

1977 Buick Le Sabre \$1,695

Used TRUCK Headquarters

1987 GMC Pickup 4 x 4 \$14,900
350 engine

1986 S-10 Ext. Cab 4 x 4 \$12,900

1986 S-10 \$7,995
A/C, Auto

1985 S-10 Blazer 4x4 \$9,595

1984 F-150 \$5,995
6 cyl., stick

1985 S-10 Pickup \$6,995
Auto. w/air

1983 S-10 Pickup \$3,995

1984 Beauville Van \$9,495
A/C, Auto

1986 Ford XL 1/2 Ton \$9,995
15,000 miles

Inside Display
OPEN SAT. 9-2
Over 60 Units in Stock
Experienced Sales Staff To Serve You
On The Spot Financing - MRP Warranty
Available On Used Cars, Backed By GM

Jack Jeffreys Russ Tell Bill Mangan
SUPERIOR
Olds Cadillac GMC
I-96 Exit 145
Brighton 227-1100

240 Automobiles
1984 PONTIAC 8000, four door, automatic, V6, \$2,900 must sell! (313)227-5781.

240 Automobiles
1984 TEMPO Diesel, 50 mpg. Excellent condition. \$3,100. (313)832-7812.

240 Automobiles
PRESTIGE MOTOR SALES
Quality Used Cars
(517)548-4414

BOB JEANNOTTE
PONTIAC IS PLEASED TO ANNOUNCE THE ARRIVAL OF GMC TRUCKS!



SAFARI PASSENGER VAN
Deep tinted glass, full carpet floor mats, body molding, intermittent wipers, air, dual mirrors, stabilizer bar, cruise, V-6, automatic, tilt, power steering, stereo, cigar lighter, color keyed bumpers, styled wheels, gauges, luxury cloth interior. Stock #5029.

\$12,483*

S-15
4 cylinder, 5 speed, full size spare, rear step bumper, 20 gallon fuel tank. Stock #5008.

\$6,493*

SAFARI CARGO VAN
Tinted glass, air, stabilizer bar, V-6, automatic, tilt, power steering, cigar lighter, AM/FM, rear door glass, gauges. Stock #5029.

\$11,193*

SIERRA PICKUP
8' box, tinted glass, defogger, air, dual mirrors, stabilizer bar, locking differential, V-8, Rally wheels, auxiliary lighting, stereo, chrome step bumper, deluxe grill, High Sierra. Stock #5007.

\$11,445*

BOB JEANNOTTE PONTIAC-GMC TRUCK

14949 Sheldon Rd. (Just N. of M-14, Jeffries Pkwy) Plymouth
453-2500 963-7192
Hours: 9-6 Tues., Wed, Fri; 9-9 Mon. & Thurs.
Plus Destination, Tax & License

WILSON FORD & MERCURY SPECIAL VALUES

1988 Taurus 4 Dr. Wagon
Air cond., elec. clock, defroster, speed control, interval wipers, 3.1 liter injected engine, auto. overdrive trans., 3rd rear seat. AM/FM cassette, clear coat paint.
\$12,995*

1988 Mustang GLX Sedan
Power locks, AM/FM cassette, speed control, road wheels, dual electric mirrors, fuel injected engine, 5 speed trans., rear defogger.
\$8,495*

4 Door Sedans \$12,595 Starting from

1988 Aero Star 7 Passenger WAGON
5 to choose from

Air cond., privacy glass, rear washer wiper, rear defroster, V-6 fuel injected engine, auto., o/d trans., speed control, tilt, clear coat paint, much more.

\$13,599*
Plus Tax, Title, Transportation, Including Rebate.

A-1 USED CARS and TRUCKS

1986 CAPRI 3 Door SPECIAL \$6,995
auto, Air, And More

1984 LTD 4 Door SPECIAL \$5,995
V-8, Auto Trans. And More

1986 VAN CONVERSION SPECIAL \$15,595
10,000 Miles, T.V., Deluxe Trim, Fiberglass, Running Boards

1982 GRANADA SPECIAL \$2,995
Auto Trans, Air

1984 GRAND MARQUIS 2 Door LS SPECIAL \$5,995

1985 LTD WAGON SQUIRE SPECIAL \$4,995
Well Equiped

1983 GRAND MARQUIS LS 4 Door \$6,595
Loaded

1984 TOPAZ \$4,295
With Sport Wheels

1985 CLIPPER SOLD \$10,595

1987 F-250 4x4 PICKUP \$14,995
Air, XLT Trim, Power Windows, Power Locks, And Much More

WILSON FORD & MERCURY
3704 W. Grand River • Brighton • 227-1771
Open Mon. & Thurs., evens; 'til 9: Saturdays 10-2

1984 DODGE Daytona Turbo-2. Excellent condition, Low miles. Black with leather interior. Factory installed sunroof. Custom stereo. \$5700 or best offer. (313)494-4393 evenings and weekends.

1984 PONTIAC 8000 LE loaded, Air, stereo, full power, etc. 6 cylinder. Very good condition. High mileage but runs great. \$2900 or best offer. (517)548-7348 after 5 p.m.

1984 BUICK Skyhawk, low mileage, excellent condition, power steering, power brakes, air conditioning, rear defog. luggage rack. Sharp. (313)246-6427.

1984 CAVALIER Stationwagon, excellent condition, am/fm, air, vinyl seats. \$1950 or best offer. (517)548-0245.

1984 TEMPO 3 door, 5 speed, cruise, power windows, am/fm, excellent condition. \$3,200. After 6 p.m. (313)885-8631.

1985 CADILLAC Eldorado. Has everything, burgandy, 28,000 miles, rustproofed and extended warranty. \$14,500. (313)246-6427.

1985 CHEVETTE CS, 4 door. Diesel, 45 mpg. 4 speed. Rustproofed. Rear defogger. Price \$2,895. (313)785-5772.

1985 DODGE Diplomat, 4 door, air, cruise, other extras. Excellent condition. \$5,300. (517)548-1038 after 6 p.m.

1986 ESCORT, \$2,600, excellent condition, am/fm radio, rear defroster, cloth seats, new brakes, new battery, well maintained, high miles. (313)498-2822.

1985 HONDA Civic 4 door sedan. Everything but air. \$5,200. (517)223-8268 after 4:30 p.m.

1985 MERCURY Lynx L, 5 door, purchased February 1985. Excellent condition. \$3,799. (517)548-2174 after 6 p.m. \$2,700.

1985 MUSTANG LX, sunroof, husband left wife with two cars! Must sell! (313)227-7144 after 6 p.m. \$2,700.

1985 OLDS Cutlass Supreme, Automatic, 8 cylinder, power steering/brakes, air, deluxe stereo, cruise, many extras, \$6,700. (313)227-9284 after 4:30 p.m.

1985 PONTIAC 8000 L2 door, silver, like new, sunroof, landau top, loaded. Make offer. (313)488-0334 call me.

1985 RENAULT Alliance, Automatic, new tires, brakes, 16.9 stereo cassette, two doors. Excellent condition. \$2,400. Call (313)437-8835.

1985 SUBARU GL, 4 wheel drive wagon, automatic, loaded! Stereo, sunroof, air, am/fm cassette, rustproofed. (313)227-510.

1986 ACURA Legend 40c, Silver/gray, cloth, 15,000 miles, low speed, sunroof, loaded. Asking \$16,000. (313)444-1585 after 7 p.m.

1986 CADILLAC Fleetwood D/Eance FWD, Loaded. Look at this one last. \$19,900. (313)827-7892.

1986 CADILLAC Fleetwood D/Eance FWD, Loaded. Look at this one last. \$19,900. (313)827-7892.

1986 CADILLAC Fleetwood D/Eance FWD, Loaded. Look at this one last. \$19,900. (313)827-7892.

1986 DODGE Caravan LE, 7 passenger, Loaded. Garage kept, 15,300 miles. \$11,500. (313)227-2945.

1986 ESCORT L, 2 door, automatic, power steering, brakes, cruise control, am/fm stereo, rustproofed. \$5,500. (313)832-7081.

1986 FIRO SE, 6 auto, air, cruise, tilt, silver, \$6999. (313)231-3021.

1986 FORD Escort LX Station Wagon, Excellent condition, rust proofed. \$8,000. (517)223-8587.

1986 FORD Escort Wagon, Many options. Low mileage. Must sell! (313)27-5296.

1986 GRAND AM black, cruise, air, stereo cassette, power steering/brakes, 4 cylinder, automatic. Excellent. \$8,000. (517)548-1297 after 6 p.m.

1986 GRAND AM LE, 38,000 miles, V-6, Automatic, 4 door, air, rear defogger, am/fm stereo, rear exterior, grey body, 20,000 miles. (313)347-0251 after 6 p.m.

1986 OLDS 98 Regency Brougham, Power windows, locks, seats, Air, cruise, tilt, low mileage. \$11,990. (313)227-4415.

1986 PONTIAC 6000 STE, Silver with gray interior. (517)548-4414

1986 TRANS Am, Alarm, T-tops, Low mileage. Bright blue. (313)227-2919.

1987 BUICK LeSabre, 13,000 miles, extended warranty \$12,800. (313)227-5285.

1987 CADILLAC Sedan DeVille, White, leather interior, 65,200 miles. Hart-ops. (313)887-4210.

1987 CHEVETTE, 23,000 miles, am/fm cassette, four speed. \$4,895. (517)521-4884.

1987 DODGE Aspen Wagon, Many new parts. \$375. (313)829-0921.

1987 MERCURY Cougar XR7, Black, air, leather interior, power steering/brakes, good condition. (313)884-1290.

1987 THUNDERBIRD, New brakes and trans. Good transportation. \$800. (313)246-6427.

1978 BUICK Regal, Air, power, cruise, am/fm. Excellent condition. \$1,900. (313)229-5288 after 6 p.m.

HERE'S A LIST OF VOLKSWAGEN DEALERS THAT WILL SELL YOU A NEW VOLKSWAGEN FOR LESS THAN TOM SULLIVAN...

1.)
2.)
3.)
4.)
5.)
6.)
7.)
8.)
9.)
10.)

BEFORE YOU BUY OR LEASE ANY VOLKSWAGEN AT ANY PRICE FROM ANYONE FOR ANY REASON, Come See Tom Sullivan.

OPEN SATURDAYS 353-6900

25400 W. 8 Mile Rd. Between Telegraph and Grand River
TOM SULLIVAN VOLKSWAGEN

ARBOR DODGE Special Used Cars

'83 Mustang \$4350
'83 Dodge Van \$4995
'84 Skyhawk T-type \$3995
'83 Mercury Cougar \$4495
'83 Omni \$2100
'85 Aries Wgn \$5595
'86 Toyota 4 X 4 \$9195
'87 Dakota Pick-Up \$9995

FREE COFFEE MUG WITH TEST DRIVE

'86 Sunbird \$6995
'86 Daytona \$6895
'86 Caravan LE \$10,995
'85 Mini Ram Van \$5695
'86 Grand Am SE \$9895
'86 Mustang GT \$10,895
'86 Pulsar NX \$7995

Arbor Dodge
3355 Washtenaw
Just West Of Arborland
971-5000

240 Automobiles
1987 MUSTANG, 5 liter LX, 4 door, 41,000 miles, sunroof, am/fm cassette, rustproofed, more lady driven, great extra warranty coverage, backed, honest seller. You must see, must sell by 1-23-87. Super price! \$10,500. (313)889-8914 or (313)227-510.

1978 CHEVETTE Automatic, am/fm with cassette, 89,000 miles. Starts, runs good. \$2,500. (313)229-4525.

1979 CAPRI, 4 cylinder, automatic, needs head gasket. Good condition. \$800 or best. (517)548-4473.

1978 CHEVETTE 4 door, automatic, Good Condition. \$550. (313)885-8841.

1978 FORD Granada, Power steering and brakes, bucket seats, good condition. \$950. (313)877-1641.

1978 DODGE Horizon, needs work. \$275 or best offer. (313)877-1641.

1978 HORIZON, Automatic, Toyota motor and transmission, runs great. \$800. (313)877-1641.

CAR LOANS
NO PROGRAM NO CREDIT NEEDED

MR. GRAHAM
(313)885-3321

EXCELLENT VEHICLE BUYS
1985 to 1987 Chrysler, Dodge, Plymouth vans and cars for sale on take over payment basis. Call 9-5 Monday through Friday (313)229-5815.

PRESTIGE MOTOR SALES
Quality Used Cars
(517)548-4414

241 Vehicles Under \$1000.

1985 CHEVY 2, 80,000 miles. Body and interior needs work. Very little rust. Runs great. \$2,200. (313)437-0291.

1986 CHEVELLE. Many extra parts. Very restorable. \$500 or best offer. (313)437-0291 after 6 p.m.

1986 SATELLITE. 999. 1978 LeBaron. \$999 best. (517)221-8272.

1970 MALIBU. Needs engine work. \$300 or best. (313)227-5285.

1985 OLDS Cutlass 2 door, good tires, runs well, good transmission. \$350 or best offer. Ask for Elaine. (313)227-5285.

1972 MONTE Carlo. \$450 or best. (313)229-5171.

1972 2 door VWS, Not running. \$250. After 5 p.m. (313)231-1950.

1974 CHEVY Impala, 400 small block. \$250 or best offer. (313)876-2471.

1974 GALAXY. Many new parts, good winter car. \$400. (313)231-1950.

1974 MAVERICK. Good 302 motor, body has seen better days. \$250. (517)223-2823.

1974 VOLKSWAGEN. Good condition. Best offer. (313)876-2471.

1975 PONTIAC Ventura. 8 cylinder, runs! \$500. Call (313)437-7384 after 5 p.m.

1976 CUTLASS. V-8 automatic. Runs good. \$650 or best offer. (313)877-2298.

1977 BUICK Skylark. Automatic, 4 door, good heater. \$3,400. \$3,550. (313)885-815.

1977 DODGE Aspen Wagon. Many new parts. \$375. (313)829-0921.

1977 MERCURY Cougar XR7. Black, air, leather interior, power steering/brakes, good condition. (313)884-1290.

1977 THUNDERBIRD. New brakes and trans. Good transportation. \$800. (313)246-6427.

1978 BUICK Regal. Air, power, cruise, am/fm. Excellent condition. \$1,900. (313)229-5288 after 6 p.m.

SHUMAN
IMPORTS & CHRYSLER/PLYMOUTH

THURSDAY ONLY!!
November 19 8 a.m.-9 p.m.

LeBARON COUPE \$10,595
plus Tax, Title, Destination Auto., air, stereo, & much, much more!

NEW YORKER \$15,995*
Order Yours Today!

TRY US!!
must be ordered by December 15

SHUMAN
IMPORTS & CHRYSLER/PLYMOUTH
Corner of Pontiac Trail and South Commerce Rd., Walled Lake
669-2010

BILL COOK
THE BEST DEALER IN FARMINGTON HILLS
BUICK Audi PORSCHE mazda

"WHOLESALE BUDGET LOT"

WE HAVE NEW & USED TRADE-INS YOU'LL SAVE THOUSANDS!! Example

'86 FORD RANGER PICKUP \$6995	'81 CHEVY MALIBU \$2295	'81 SKYLARK \$2695	'82 MAZDA RXL GSL \$6995
'85 OLDSMOBILE CUTLASS CIERA \$4995	'85 FORD TEMPO GL \$4995	'87 CHEVY SPINNT \$6695	'83 BUICK RIVIERA \$6495
'86 FORD TEMPO GL \$5995	'79 BUICK LESABRE \$2895	'82 CHEVY VAN 3/4 TON \$4995	'84 PONTIAC FIERO \$4495
'85 DODGE D-50 PICKUP \$4495	'82 CHEVY MONTE CARLO \$4495	'85 BUICK RIVIERA \$7995	'84 VOLKSWAGEN SCIROCCO \$5995

OVER 50 CARS AT SIMILAR SAVINGS!
37911 GRAND RIVER FARMINGTON HILLS 471-0800
"ASK FOR THE BUDGET LOT"

DICK MORRIS BEST DEALS LOWEST PRICES DICK MORRIS BEST DEALS LOWEST PRICES

CHEVY TRUCK SPECTACULAR

'88 S-10 PICKUP
Power Brakes, 5 speed, P 195/75 R-14, Radials, 2.5 Liter Fuel Injection, 1000 Lb. Payload. Stock No. 3010.

SALE PRICE \$6780
OR LEASE FOR \$149.87 *Per Month

'88 1/2 TON PICKUP
4.3 Liter, Fuel Inj., Stabilizer Bar, Dome Lamp, Cig. Lighter, Tinted Glass, P225/75 R-15 Radials, Stock No. 2348

SALE PRICE \$9495
OR LEASE FOR \$218.05 *Per Month

'87 1/2 TON PICKUP
Vortec Fuel Injection, V-6, Power Steering, Power Brakes, Heavy Duty Rear Springs, Big P225/75 R15 Steel Belted Radials, Rally Wheels, AM/FM Stereo, Gages, Dome Lamp, Cig. Lighter and more. Stock No. 2031

SALE PRICE \$8999
OR LEASE FOR \$199.87 *Per Month

'87 SPECTRUM EXPRESS
LEASE FOR \$139.20 *Per Month

THIS WEEKS SPECIAL

Dick Morris CHEVROLET
"Your Favorite Chevrolet Dealer"
2199 Haggerty Rd., Walled Lake
624-4500

NO HIDDEN COSTS-ALL YOU ADD IS TITLE, TAX & PLATES

GM & QUALITY SERVICE PARTS

Mon & Thurs 7-9
Tues, Wed, Fri 7-6

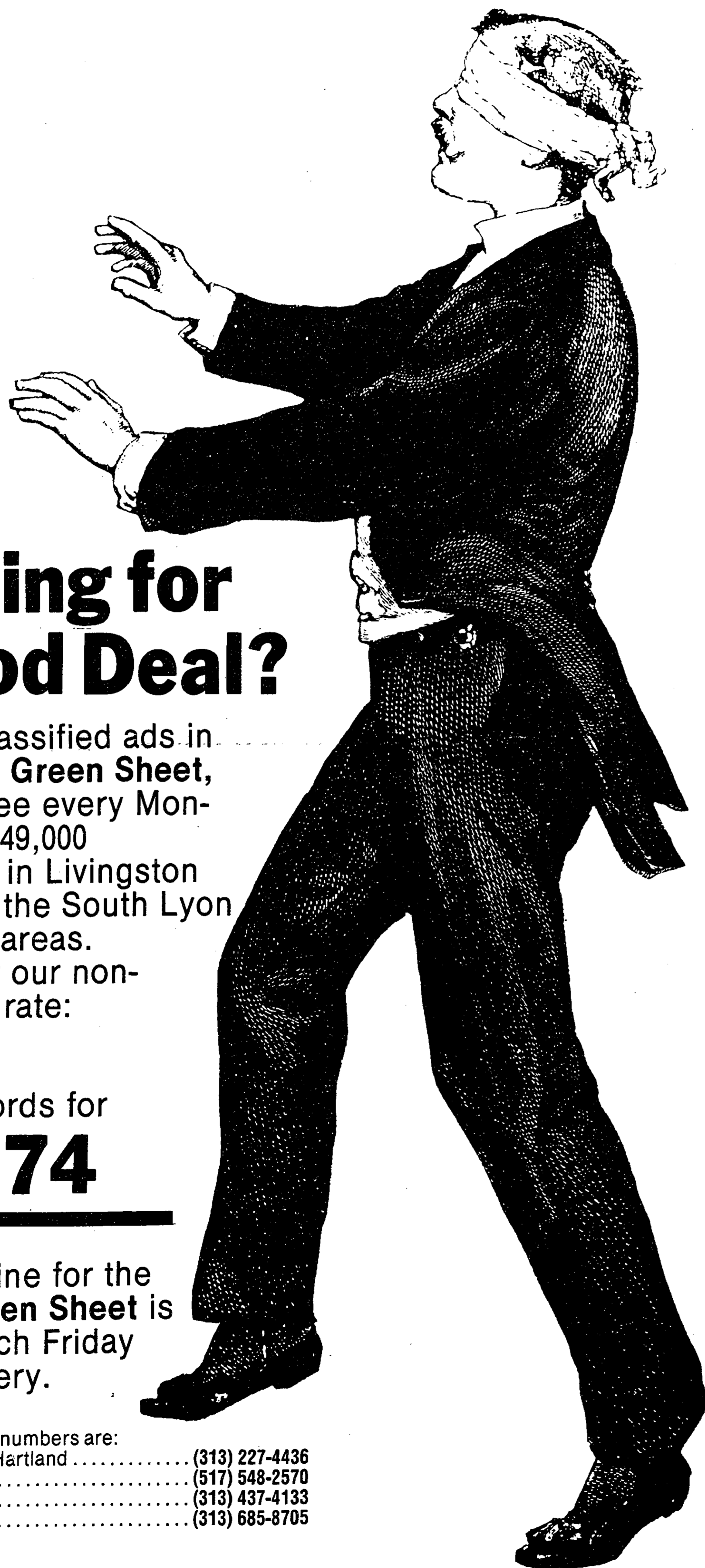

Looking for a Good Deal?

Try the classified ads in the **Monday Green Sheet**, delivered free every Monday to over 49,000 households in Livingston County and the South Lyon and Milford areas.

Look over our non-commercial rate:

10 words for **\$5.74**

The deadline for the **Monday Green Sheet** is 3:30 p.m. each Friday before delivery.

Call us. Our phone numbers are:
 Brighton/Pinckney/Hartland (313) 227-4436
 Howell/Fowlerville (517) 548-2570
 South Lyon area (313) 437-4133
 Milford area (313) 685-8705

the NOVI NEWS

Living

HIGHLIGHTS:
 Novi ministers plan Thanksgiving Eve service/2C

SHEILA MacRAE:
 Celebrity speaks on 'Ladies who Last' /3C

CIVIL WAR BAND:
 Novi group recalls Michigan Regiment Band/5C

DIVERSIONS:
 Art Institute busy with holiday programs/8C

1C

THURSDAY
 November 19, 1987



High-tech time savers for the cook

Tired of spending the entire day of Thanksgiving in the kitchen, rather than engaging in scintillating conversation with family members and friends?

Thanks to the wonders of modern technology, there are ways to make Thanksgiving easier on the cook and more enjoyable for everyone.

The microwave oven was developed especially for Thanksgiving. I don't care what the inventors of the machinery say, it is a real boon on Turkey Day.

A lot of the trimmings, such as pies, stuffing and potatoes can all be made in advance — in some cases weeks in advance — and then reheated in the microwave.

Given that the idea behind this story is to get as much done early as possible, here's a timetable for Thanksgiving cooking which leaves the cook relaxed and cheerful on the special day.

One week to T-Day

Make potatoes and pies. Of course, purists would faint at the idea of using ready-made rather than fresh materials, but a number of grocery stores in the area have everything the cook could need for pies.

Ready-made pie crusts come

frozen in the grocers' freezers or packaged on the shelves.

Modern cooks have their choice of pie crusts including graham cracker crusts, chocolate-flavored, or butter-flavored in the fresh variety, and your standard crusts in the frozen food section.

Fillings for pies are also available in the canned or frozen varieties. And, for those looking for a new treat, some stores even sell ready-to-eat plum pudding.

Potatoes freeze beautifully, especially mashed or twice-baked. Those who don't have the time to peel and mash potatoes early can even buy already-prepared twice baked or stuffed spuds.

And for those who aren't particular about their potatoes, a couple of boxes of potato flakes could be just the ticket.

Three Days to T-Day

Make salad, prepare veggies. Cooking for 50? Plan on serving tossed salad? Take heart. That's why large garbage bags were invented.

There's no need to prepare your salad at the last minute. Just cut up those vegetables and put them all together in the garbage bag in the refrigerator.

Then, take out the amount you need and dress your salad right at the table. For refills, just reach into the bag and pour out some more. It's easy if you plan ahead.

If you opt not to use frozen vegetables (which, by the way, cook up quickly and tastily in a microwave) and choose instead to use fresh, get them cleaned up and ready to go into the oven early.

Planning leaves time for cooks to socialize

Of course, if you elect to use canned vegetables, the taste can be improved considerably by taking them out of the can and letting them sit in your refrigerator at least 24 hours.

Thanksgiving Eve

Prepare stuffing. Stuffing comes ready-made or almost ready-made and all types are available at local stores. Stove Top comes in a box and is totally complete, including seasonings, while Pepperidge Farms offers seasoned bread crumbs that are either cubed or crushed.

Turkey Day

Cook everything. Here's where your microwave comes in really handy. What could take hours in a conventional oven, takes minutes in the microwave. Of course, microwaving a turkey requires either a very big microwave or a very small turkey. And microwaving leaves out a very important part of the holiday, the smell of a basting turkey.

If all this sounds like too much work, take heart. Two other options are still available. The first, for those who want to travel, is to make reservations at one of the restaurants that is serving Thanksgiving dinner.

The second is to allow the dinner to be catered. It just depends on how much time you've got.

— Anita Crane

Random Sample

Q: Are you ready for winter?

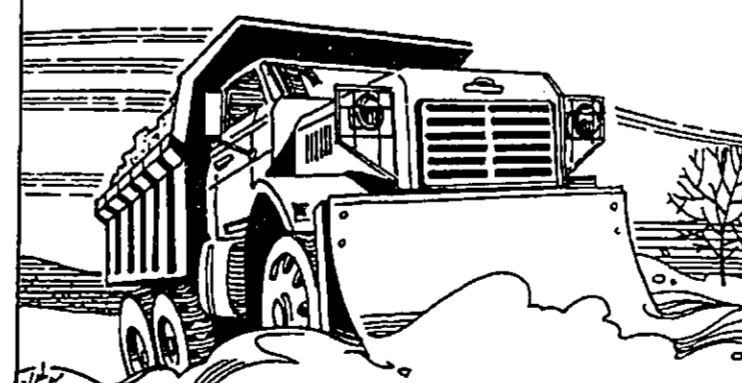

Six said: "No" (One respondent added, "No, never.")

Three said: "Yes" (One respondent added, "Yes, I'm a skier.")

One said: "I don't care, I'm going to Florida."

Random Sample is an unscientific poll of 10 Northville/Novi residents conducted by the staff of this newspaper

Newspaper staff rates frozen turkey

Not everyone has a grandmother or an aunt who is going to prepare a hearty Thanksgiving Day feast. In an effort to not leave anyone out during the pending Thanksgiving Day holiday, here is a guide to the turkey dinners offered for sale in your grocer's freezer.

The staff of The Northville Record and the Novi News became turkey tasters of six choice dinners, picked mainly because they were microwave-able.

Each one was sampled in order to make a comparison of taste, appearance, scent and price to offer you — the single, lonely and hungry — a comprehensive guide for cooking the ultimate in a convenient holiday dinner.

There are obvious benefits to all of the dinners tested: most were prepared within 5-15 minutes, there was virtually no preparation required, and clean-up was a breeze.

As far as convenience goes, there is no better way to enjoy a meal and be able to watch the Thanksgiving Day parade on television at the same time.

The newspaper staff, with plastic forks in hand, tasted and rated the following dinners: Banquet Turkey Dinner; Swanson Hungry Man; Stouffer's Lean Cuisine Turkey Dijon; LeMenu Sliced Turkey Breast; Swanson's Turkey Dinner; and Stouffer's Turkey Casserole.

The dinners were rated on a 1-25 scale (five points per each taster, with five points being the top score) for taste, scent and visual presentation. Our resident mathematicians then calculated a total rating point based loosely on the cost per ounce of each dinner. The bottom line was which tasted best.

Actually, on the whole, most of the dinners were very tasty, and each had at least one quality which made it worth trying.

The following is a summary of how each dinner was received. We'll start with the best one first, and work our way down:

Frozen Feasts		
Rating frozen turkey dinners		
The following dinners were rated on the basis of taste, appearance, aroma and cost. Testing was done by the staff of this newspaper.		
Dinner/Comments	Points	
1. Stouffer's Turkey Casserole	132.5	Not much for appearance but best tasting of the bunch.
2. Swanson Hungry Man	125	Lots of tasty meat; salty stuffing but perfect peas
3. Swanson Turkey Dinner	106.25	Like no. 2 but skimpier; crunchy stuffing and fatty meat
4. Banquet Turkey Dinner	75	Worst tasting meat of the lot. However, corn was excellent. Also, it was the least expensive dinner we tried.
5. Stouffer's Lean Cuisine Turkey Dijon	43.75	Tastes better than it looks; gives off artificial feel
6. LeMenu Sliced Turkey Breast	41.07	Looked most appetizing but taste was a letdown. Vegetables were only tasty items; most expensive of the lot.

Graphic by JEFFREY LAPINSKI

Continued on 4

Staff ratings of the TV dinners

Continued from 1

Stouffer's Turkey Casserole
Although, when cooked, it was far from appetizing, this dinner tasted the best without a doubt.
The turkey stuffing was a little on the runny side, but because of its down-home spices and fine tasting gravy, it tasted most like something your mother would prepare. The dinner cost \$1.99 and we gave it 132.5 total rating points.

Swanson Turkey
This dinner appeared to be almost identical, in terms of content, to the Hungry Man dinner, but as far as taste goes, it left more to be desired.
The stuffing was hard and crunchy, the meat contained more fat, but the green peas were still wonderful.
As one staff taster commented, "It wasn't bad when you mixed everything together."
This dinner cost \$1.87 and we gave it 106.25 rating points. (Its low cost boosted it higher in our overall rating.)

Banquet Turkey
It is tough to say much about this one. But its cost of \$1.05 landed it higher on our ratings scale than it probably deserved.
The turkey was processed. It looked horrible, and its taste was disappointing. Actually, the stuffing in the dinner was among the best tested, and the corn included in the dinner was very tasty. But the turkey was reason enough for most of our staffers to rank it lower.
The Banquet dinner received 75 rating points.

The scent was what threw our staff off. It wasn't the best smelling turkey we have ever eaten.

LeMenu Sliced Turkey Breast
At first appearance, glowing with broccoli and carrots and sprouting mushrooms, we thought this dinner would be the best.
But looks were deceiving. The turkey meat was tasteless with the gravy being the only ingredient giving any taste at all.

The vegetables were tasty, but, as with all of the dinners tested, we found that it is pretty hard to go wrong with them.
"The dinner started out good, but went down hill all of the way," said one taster.

At \$3.18, this dinner was the most costly one tested, and it received only 41.87 rating points.

Lean Cuisine Turkey Dijon
Without a doubt, the worst-looking dinner cooked. But once you got past the sight, its taste wasn't really bad. It did leave you feeling, however, that you had just finished eating an artificial meal albeit this is a dinner those who are calorie counters purchase.

Engagements

The engagement of Diane Marie Waldenmayer to Jeffrey Thomas Greiner of Farmington Hills is announced by her parents, Mr. and Mrs. Donald Wesley Waldenmayer of Ten Mile in Novi.



DIANE WALDENMAYER and JEFFREY GREINER

The bride-to-be graduated from Novi High School in 1983 and went on to attend Schoolcraft College in Livonia. She currently is employed as a legal secretary at the firm of Cummings, McCloy, Davis and Aho, P.C.

The prospective groom is the son of Mr. and Mrs. Thomas Greiner of Novi Street in Northville. A 1983 graduate of Northville High School, he went on to attend Schoolcraft College in Livonia and currently is employed as maintenance supervisor at Muirwood Apartments in Farmington Hills.
The couple is planning a May 1988 wedding date.

In Uniform

Navy Petty Officer 1st Class ROBERT FOLLETTE recently departed for a six-month deployment to the Mediterranean Sea aboard the destroyer USS Caron, homeported in Norfolk, Virginia.
A 1972 graduate of Atlanta (Mich.) High School, he is the son of Lois Heron of Novi and joined the Navy in July 1972.
During the deployment, Follette will participate in several exercises including "National Week." The USS Caron also will be celebrating her 10th year of active service while deployed. Port calls will include Valencia, Spain; Athens, Greece; Alexandria, Egypt; and Haifa, Israel.

Airman ROBERT SCHWIND has graduated from Air Force basic training at Lackland Air Force Base in Texas. A 1986 graduate of Walled Lake Western High School, he is the son of Charles Schwind of Wixom and Ravind Larkin of Canton.

Novi group active in Civil War band

By KATHLEEN MUTCH special writer

Anyone who thinks the Civil War is not beyond memory is laid to rest in our 15th Century past... has not met the members of the 5th Michigan Volunteer Infantry Regimental Band or its director, Novi resident Guy Smith.

Organized during the U.S. Bicentennial as a Sousa-type parade band, the present 5th Michigan Regimental Band has returned to its historical and musical roots.

The original 5th Michigan Regiment, mustered in the 1860s, recruited farmers, shopkeepers, adventurers and teachers, some of whom were musicians, from the farms and villages of southeastern Michigan.
The present band, made up of musicians who share an intense interest in Civil War history, is an equally diverse group. The band includes re-enactors who are not musicians, a government auditor, a nurse, a computer engineer, a retired fire chief and several teachers.

The re-enactors form a support group for the musicians and just as enthusiastically relive the Civil War era. The whole MacQueen family of Novi is active in some way - Doug and Judy are musicians, daughters Cathy and Carol are, too, and young Glen is a flag bearer in the color guard.

On Thursday nights Civil War music can be heard echoing down the hallways of Novi Meadows School on Fair Road. Band members come from neighboring communities and from as far away as Grand Rapids and Ohio, to practice a repertoire of 60 period pieces.
According to Smith, there are only 10 bands in the U.S. which specialize in the music of the Civil War era. The 5th Michigan Regimental Band is one of only four for whom the band is not a full-time profession or occupation.

"We are unique in Michigan. And," says Smith with pride, "we are right here in Novi."
Band members, dedicated to authenticity, have researched the history and music of the Michigan regiment. They have re-created the music, uniform and dress, and the performance style of the original 5th Michigan Regimental Band.

Using preserved manuscript copies as a guide, Smith has written instrumentation which allows musicians to use modern instruments to achieve the unique sound of the "regimental field band."

Although the instruments are not antiques, they are traditional in design and construction. There are

When the troops were on the move, the band kept a cadence that urged the regiment, a thousand strong, along to the next encampment. The band would play to inspire the meek, comfort the defeated, celebrate the victorious and mourn the dead.

none of the 20th century percussion and horn inventions found in a modern-day competitive drum and bugle corps, for example. The two snare and single bass drums are made of wood, without metal, and have rope-tied heads.

A field band was limited to "22 bandsmen and two musicians," the latter designation reserved for the director and drum major. The 5th Michigan has many more musicians, but strictly observes the limit in performances.

The band recently acquired five "over-the-shoulder" Sax horns which will add to the authentic sound and appearance of the band. Sax horns, named for their inventor, look like uncoupled versions of a trumpet, trombone, tuba, baritone and French horns.

Sax horns were invented for 19th century military use. They were used in field bands from about 1850 to 1880 when the band was an essential part

Continued on 6

Thanksgiving is time to 'talk turkey'

You might think that because turkey is the main attraction for most American holiday meals that most consumers know all they need or want to know about how to buy, store, thaw, stuff and prepare it.

Not so - so let's talk turkey.
When purchasing a turkey you can figure on one pound of turkey per person (one and one-quarter pounds if the turkey is pre-stuffed). This will allow generous servings with enough left over for second day dishes.

Make sure you allow enough time for thawing your turkey. "Thawing in the refrigerator is the safest way," said Linda Cornell, Oakland County

Home Economist. For each five pounds of turkey allow 24 hours in the refrigerator.

It may seem like a good idea to save time by stuffing your turkey in advance - not true. That's inviting trouble because bacteria can multiply in the stuffing and cause food poisoning. Stuff your turkey immediately before placing it in the oven and cook until a thermometer in the stuffing reaches 165 F. Allow three-quarters to 1 cup stuffing per pound of ready-to-cook weight. Stuff the wishbone cavity lightly - do not pack.

Roast your turkey in a 325 F oven with a meat thermometer inserted into the thickest part of the thigh muscle without touching the bone. Roasting which is the easiest method gives you a golden

brown turkey with a rich roasted flavor.

Finally, separate the turkey and dressing and refrigerate immediately. How you store leftovers is important in preventing bacterial growth. Large quantities should be divided into smaller portions and stored in several small or shallow-covered containers. Leftover turkey will keep in the refrigerator for three to four days. Stuffing and gravy should be used within one to two days. Bring leftover gravy to a rolling boil before serving. For longer storage, package items in a moisture-proof wrap and freeze them.

For more tips on turkey, contact the Food Preservation/Food Safety Hotline, 858-0904, Oakland County Cooperative Extension Service.

Learn CPR ...
WHERE FIGHTING FOR YOUR LIFE
American Heart Association of Michigan

CREATIVE WORLD has ART CLASSES.
NOVI 344-4333

SUNDAY ONLY ART SALE
MOST UNDER \$39
NORTHERN ART GALLERY
HOLIDAY INN - LIVONIA WEST
1-275 & 6 MILE

CHRISTMAS CRYSTAL
All the trimmings for your tree...
CHARLES W. WARREN JEWELERS SINCE 1902

Perkos BUTTER BROWN
SNOW-MANS-LAND
NORDIC NAVY/RED GREY/RED KHAKI SIZES 9 to 12 \$23.99
SLEIGHBELLS NAVY PINK SIZES 7 to 12 \$22.99

Two great names to beautify your home: Commercial Carpet Corporation and STAINMASTER CARPET
40400 Grand River Suite A Novi, MI 48050
477-7722

CHRISTMAS COLLECTIBLES
Silver treasures for your tree...
CHARLES W. WARREN JEWELERS SINCE 1902

PLYMOUTH NURSERY'S 72 HOUR-50% SALE
Christmas in the Country
7' European Mt. Pine Now \$124.95
7 1/2' Sitka Spruce Now \$99.95
7 1/2' Western Balsam Fir Now \$99.95
PLYMOUTH NURSERY Christmas in the Country

we care hair
\$6 HAIRCUT
\$200 OFF STYLING COUPON
\$600 OFF PERM COUPON
we care hair

CHRISTMAS COLLECTIBLES
Silver treasures for your tree...
CHARLES W. WARREN JEWELERS SINCE 1902

ROPA TAN Novi's Total Tan Center
Look At This Offer!
1 Month Unlimited Tanning \$29.95
1 Month Unlimited Tanning, Anytime Reg. \$70 \$49.95

DISCOUNTED SAILING 8 Day
Royal Caribbean Cruise
February 13, 1988
\$1252 Per Person
CALL 476-3433

Laurel FURNITURE
Pennsylvania Solid Cherry
CALL 476-3433

How do you get all the advantages of whole life and term protection in one policy?
No problem.
Frank Hand Insurance Agency

FUELISH OFFER
FREE GAS FOR 2 MONTHS WITH EVERY LONG-LIVED BRYANT FURNACE WE INSTALL BEFORE JANUARY 31.
CALL TODAY 474-2226

Thanksgiving Extravaganza HARVEST BUFFET
Thursday, November 27 11 am-5 pm
Adults \$12.95, Senior Citizens \$11.95
Sheraton Oaks

Medicare a pain?
We've got the cure.
HCR

In Shape

theNOV
NEWS
6D
THURSDAY
November 19,
1987

COUPON
ARE YOUR WINDOWS FOGGED, CONDENSATED OR STAINED??
Replace your bad glass at a fraction of the cost of new windows or doorwalls. **1 YEAR WARRANTY**

20% OFF OUR FINEST GLASS
THERMOPLANE INSULATED GLASS REPLACEMENT

Measure & Call for FREE Phone Estimate
ARTIC WINDOW REPLACEMENT IND.
33688 FORD RD. • WESTLAND • 522-4440
—WITH THIS AD—

Dance your way to better health

Dance your way to fitness? Absolutely.

In fact, taking a course in ballroom dancing could rate as one of the better fun ways to lose weight and trim down.

Curtis Gundie, owner of the Arthur Murray Dance Studio at 42947 West Seven Mile in the Highland Lakes Shopping Center in Northville, reports that a current student, Sandy Specht, has lost 20 pounds at the studio.

"You can work up a nice sweat with a Viennese waltz," says Gundie. Instructor Michael Monet adds that the Latin American dances — the Rumba, Samba, Tango and Cha Cha — are energy-expending dances. "It doesn't seem like a lot of energy, but you use up more dancing than walking," he says.

Last Thursday evening a regular customer at the studio for the five years it has been open was dancing with Linda whom staffers call "unique" as she "is into the '20s, European style." The green felt hat she was wearing matched her fitted jacket.

Across the room two newcomers that evening were following their teachers through a basic swing pattern — one, two, three, four, five, six and rock."

This year marks the 75th anniversary of the founding of the Arthur Murray dance studios, and much of the instruction remains as popular as ever. "It's never gone out of style, you'll never replace the waltzes and foxtrots," declares Gundie.

He notes that students range in age from 18 to 80 with most signing up for an introductory program of five 30-minute lessons for \$25. The sessions may be doubled up and include basic dance styles.

From there a program can be tailor-made for an individual, depending upon how expert a dancer wishes to become. Costs range from \$200 to \$2,000, explains Gundie, noting that the program includes competition in exhibitions with special routines as well as group classes and Friday night practice sessions.

Two students from the Northville studio placed second and third in their respective dance categories in a recent competition in Florida. The Northville studio attracts dancers from Canton, Plymouth and Ann Arbor as well as the Northville-Novato area.

Recently, Gundie has seen a new interest in ballroom dancing on the

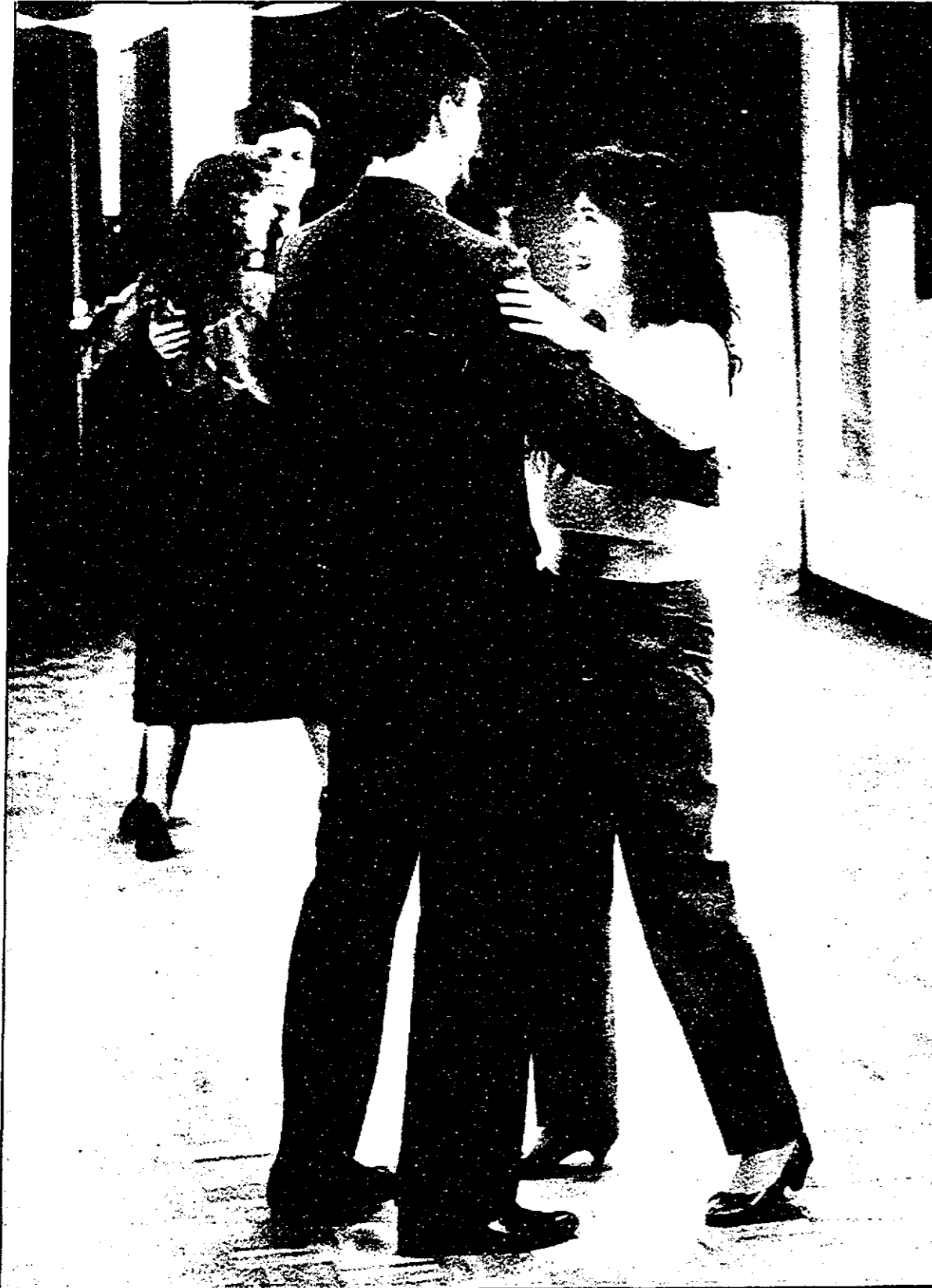

Beth Sanavage learns a dance step from instructor Rich Thurston

Novi News/CHRIS BOYD

part of couples planning their weddings. "They come in to prepare to waltz at their weddings," he says. Gundie himself instructs his teachers, all neatly suited, and brings in experts from outside the state

to keep instruction current. It looked like fun last week as the couples took to the floor as a recorded vocalist sang, "Do I wanna, Do I wanna..." "Yes, they did. And, anyone who doubts that dancing is the route to fitness need only

note that Arthur Murray, now 92, and his wife Kathryn who together taught the world "dancing in a hurry" are alive and well in Hawaii. —Jean Day

Novi Trackers welcome runners

Enjoy camaraderie with fellow running enthusiasts of all ages and abilities by joining the Novi Trackers Running Club. For more information contact Lee Karvola at 349-7224 or Kelley Simpson at the Novi Parks and Recreation office, 349-1976.

Open swimming: The Novi High School swimming pool is open for general use every Tuesday and Thursday night through Nov. 24.

Open swimming runs from 7:30 p.m. and lap swimming is available from 8:30 to 9:30 p.m. There's a fee of 50 cents per person. Call Novi Community Education at 348-1200 for more information.

Mercy Center Programs: The Mercy Center on Eleven Mile and Middlebelt Road in Farmington Hills is offering an open swim and fitness program daily through Dec. 18. The early morning swim is held Monday through Friday from 6:30 to 8:30 a.m. and Saturday from 7:30 to 9 a.m. It includes lap swims, private lessons, swim classes, adult synchronized swim club and adapted aquatics.

Fitness notes

The Fitness Program, call Trim-Gym-Swim, is designed to strengthen and tone and body. Call 478-8010 for more information.

A Sunday Health Club is offered at Schoolcraft College every Sunday. Membership in the club enables individuals and families to spend several hours on Sunday afternoons in unstructured physical activity in a modern, full-equipped physical education complex.

Facilities include two gyms for basketball, badminton, volleyball and jogging; six handball, paddleball and racquetball courts; weightlifting machines; a swimming pool and saunas. Memberships for the 14-week fall session are \$22 for individuals and \$60 for families. A 28-week membership (for the fall and winter sessions) is \$40 for individuals and \$105 for families. For more information call Schoolcraft College at 591-6400, extension 409.

Open Swimming: Open swimming at the Northville High School pool is offered every Monday and Wednesday from 6:30 to 7:45 p.m. The pool is also open for open swims on Saturday from noon to 1 p.m.

Free Speakers Offered:

Hospitals are now teaching people to stay healthy, and Harper-Grace Hospital is doing its part by providing free speakers on over 500 health care topics to any organizations are asked to make speaker requests far in advance. For a complete list of Speaker Bureau topics or more information about the program, call Harper-Grace Hospital's public relation department at 745-8303.

Focus On Women Program:

The Focus on Women Program of Henry Ford Community College will offer seminars in aerobic exercises, effective parenting, massage techniques and self defense this fall, for more information, call the Women's Resource Center at 845-9629.

Fitness Tips

A quick look at ballroom dance steps

Ballroom dance students at Arthur Murray are introduced to the ballroom basics: From the fox trot — the most popular dance of all time, to the present — the hustle, a contemporary disco-swing.

For those contemplating what to learn, here is a list of the introductory steps with descriptions by the Arthur Murray Dance Studios:

- Fox trot (most popular dance) — step, left turn, promenade walk.
- Swing (the American fun dance) — swing basic, swing release, underarm turn and left-right.
- Waltz (the basis of all dances) — left box turn, closed hesitations, underarm turn right.
- Rumba (the Latin foundation dance) — rumba box, rumba breaks,

underarm turn...
□ Samba (the Brazilian waltz) — samba basic, underarm turn, belancetes.
□ Tango (the most dramatic) — tango walk, tango walk with left turn, medio corte.
□ Cha Cha (a personality-revealing dance) — basic turning, cross over and walk around, open break with underarm turn.
□ Mambo (abandonment with control) — turning basic, cross over break, open break with underarm turn.
□ Merengue (the Latin fox trot) — basic, separation, underarm turn right.
□ Hustle (contemporary disco swing) — hustle basic, underarm turn left, throw out.



**CITY OF NOVI
NOTICE OF ENACTMENT
ORDINANCE 87-18.47**

NOTICE IS HEREBY GIVEN that the Novi Council has adopted Ordinance 87-18.47, an Ordinance to amend the dwelling unit density/type regulations within Sec. 2404 of Ordinance No. 84-18, as amended, the City of Novi Zoning Ordinance; to amend subsection 2402.2 of said Ordinance; to amend Sec. 2404 of said Ordinance; To Permit Open Space Subdivisions, and Residential Unit Developments within the R-4 Residential-Agricultural Zoning District; and to amend Subsection 2514 of said Ordinance to regulate the expiration of preliminary and final site plan approvals.

This Ordinance was declared to be an emergency Ordinance which is immediately necessary for the preservation of the public peace, health and safety, and took effect immediately upon adoption. The Ordinance was adopted on November 16, 1987, and the effective date is November 16, 1987. A complete copy of the Ordinance is available for public purchase, use and inspection at the office of the City Clerk during the hours of 8:00 AM to 5:00 PM, local time.

GERALDINE STIPP
CITY CLERK
(11-19-87 NR, NN)

**CITY OF NOVI
NOTICE OF PUBLIC HEARING
1988 COMMUNITY DEVELOPMENT FUNDS**

PLEASE TAKE NOTICE that the City of Novi will hold a Public Hearing on the Housing and Community Development Funds. The Hearing will be held Monday, November 23, 1987 at 8:00 P.M. at the Novi Public Library, 45245 W. Ten Mile Road, Novi, Michigan, 48050, for the purpose of encouraging citizen input in the proposal to spend federal funding to be received from the Housing and Community Development Act.

All interested citizens are requested to attend this Hearing. Comments will also be received in writing or in person at the City Offices, 45225 W. Ten Mile Road, Novi, Michigan, 48050, until 5:00 P.M., prior to the hearing.

GERALDINE STIPP
CITY CLERK
(11/19/87 NR, NN)

CUSTOM DECK EXPERTS

Let us help you design a deck to compliment your home and satisfy your outdoor needs.

We feel that pressure treated Ponderosa Pine is the best material for the job. It's treated to a .40 retention. It has a better appearance, less warping and less splitting than Yellow Pine.

Lumber is guaranteed for 30 years.
Free Design Service
Free Delivery Within A 70 Mile Radius

H.A. SMITH
Lumber & Supplies
28575 Grand River (near 8 Mile)
Hours: Monday-Friday 7:30-5:30; Saturday 8:00-4:30
474-6610 or 535-8440

Everything in Treated Lumber

FASHION UPDATES

Add one of our unique attachments or slides to any chain or collar, and you have the perfect way to update your jewelry wardrobe. From our collection:

- 14k gold and diamond combination slide and pin, \$1600.
- 14k gold, diamond and blue topaz attachment, \$1100.
- 14k gold collar, \$995.

CHARLES W. WARREN
JEWELERS SINCE 1902
SOMERSET HALL (313) 849-3411
EASTLAND - LANSING - FARLEIGH
TELE. 6484

Let our own 50th or 60th or 75th Anniversary Logos... Use on Nameplate

**Created For The Special Woman
In Your Life...**

Diamond Necklaces

Eternity Bracelets

From \$1900 (2.65 ct of diamonds)
To \$12,000 (13 cts of diamonds)

Layaway Now For Christmas

diamond boutique
Custom Made Jewelry Exquisitely Designed To Be Exclusively Yours

37105 Grand River, Farmington
Grand River/Halsted Plaza 478-3131

When you buy from Diamond Boutique you save 40% to 70% off retail because we manufacture our fine jewelry and pass the savings on to you

Major Credit Cards Accepted

Grand River/Halsted Plaza

Gift Guide

In the Merry Spirit of Yuletide Joy

In the very merry spirit of Yuletide joy and cheer, we're celebrating Christmas throughout the stores right here! Each merchant has been busy stocking up on gifts galore...to provide the best selection of everything and more! They've worked to have it festive and filled with cheer and fun...so that shopping here is a delight for everyone.

**K-Mart • Kroger • Perry Drug Store
Winkelman's • Card & Gift Center • Video Studio
Diamond Boutique • Washington Clothiers
Little Professor Book Center • Koney Island Inn
Bo Rics Hair Care Salon • Heritage Cleaners**

Grand River/
Halsted Plaza

Supplement to the
Novi News, Northville
Record, Farmington
Observer, November 1987

Little Professor Book Center
3715 Grand River at Halsted
Farmington
478-2810
Mon-Sat, 10 a.m.-9 p.m.; Sun, 10 a.m.-5 p.m.

LARGE SELECTION OF 1988 CALENDARS
\$2.95 to \$12.95

Phonochio
Heidi
Little Women
Peter Pan
A Christmas Carol
CHILDREN'S CLASSICS
Patricia Hooper
A BUNDLE OF BEASTS
POLAR EXPRESS
Book & Bunny
PAT THE BUNNY
Children's Books
BIG TEN FOOTBALL
PICTORIAL HISTORY OF HOCKEY
GREAT PAGES OF MICHIGAN HISTORY
A DAY IN THE LIFE OF THE SOVIET UNION
CHRONICLE OF THE 20TH CENTURY
PICTURES
ANDREW WYETH: THE HELGA
RANDOM HOUSE DICTIONARY OF THE ENGLISH LANGUAGE
100 Years of Adventure & Discovery
NATIONAL GEOGRAPHIC SOCIETY

45.00
79.95
40.00
49.95
39.95
14.95
17.98
12.98
17.00
15.95
12.95
8.98

We help you find books you'll love.

KONEY ISLAND INN
Family Restaurant
(next to K-Mart)
Grand River at Halsted, Farmington
Now Open 7 A.M. - Friday
8 A.M. Sat. & Sun.

Breakfast Special!
2 Large Eggs with Meat,
Hash Brown Potatoes
Toast & Jelly
All For \$1.99
Mon-Sat 7-11:30 a.m.
Sunday 8 a.m.-2 p.m.

Check Menu for Other Specials

20% OFF
Your Total Bill
After 2 p.m. Only
Expires December 15, 1987

Complete Fast Carryout Service
478-0440

Heritage Cleaners
Now Open!

3703 Grand River at Halsted
Farmington, MI 48024
Phone: 473-0100

Store Hours:
Mon.-Fri. 7-7
Sat. 8-5

Services:
1. 1 Hour Dry Cleaning
2. Shirt Laundry
3. Alterations
4. Suedes & Leathers
5. Pillows Cleaned
6. Reweaving

20% OFF
All Incoming Dry Cleaning Orders
With this coupon
Expires 12/15/87

20% OFF
All Incoming Dry Cleaning Orders
With this coupon
Expires 12/15/87

KROGER MEANS BETTER MEAT

37025 GRAND RIVER
GRAND RIVER & HALSTAD
STORE HOURS
MONDAY THRU SATURDAY
8 AM to 10 PM
SUNDAY 9 AM to 6 PM

Wed., Nov. 25, 1987
Prices Good Thru

59¢
Grade A
10-Lb. and Up
KROGER
FRESH TURKEYS
Limit One Please

329¢
Whole Or Half
Fully Glazed
SPIRAL
SLICED HAM
Limit One Please

99¢
Frozen
MINUTE MAID
ORANGE JUICE
12 Oz. Can

197¢
Assorted Flavors
KROGER DELUXE
ICE CREAM
1/2 Gal. Can

259¢
Assorted Flavors
BIG K
POP
Plus Deposit
Bottle

1099¢
Beautiful, Seasonal Flowers
NEW CROP
NAVEL ORANGES
Large 88 Size
From \$10.99

DOUBLE Limited To Manufacturer's
COUPONS Coupon Valued Up To \$50
See Store For Details

shop the store that's filled with imagination

Imaginative gifts. And imaginative people.
We have great holiday ideas. Imaginative ideas that will help you enjoy a wonderful holiday.

winkelman's

GRAND RIVER/HALSTED PLAZA

VIDEO STUDIO
37061 Grand River 476-1970

THE GOLDEN CHILD
COUPON-COUPON-COUPON
\$1.00 OFF
Any LaserDisc
COUPON-COUPON-COUPON

STAR TREK IV THE VOYAGE HOME

ORDER TODAY!
Critical Condition

JUMPIN' JACK FLASH

RENTALS FOR THE PRICE OF 2

MON-SAT 10:30-9 p.m.
Sun 12-6 p.m.

Mike Ditka wins with Sansabelt slacks

Staying comfortable and looking trim in action is important to Chicago Bear's coach Mike Ditka. That's why he picks Sansabelt® slacks for his wardrobe. Make Sansabelt a winner in your wardrobe too.

washington clothiers

Farmington's Only Complete Men's Store
Grand River at Halsted
478-3430

Mon-Sat 10-9 Sun 12-5
All Major Credit Cards

Santa Suggests Great Gift Ideas!

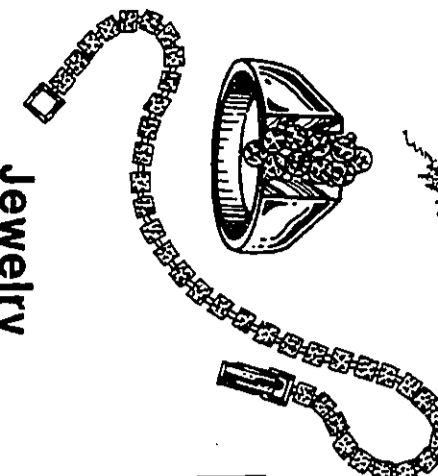

Jewelry

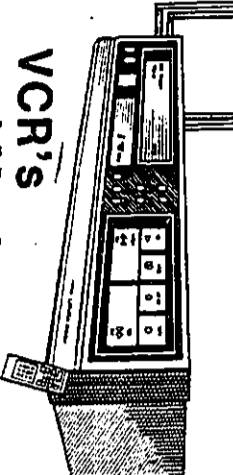

**Books & Calendars
Gift Certificates**

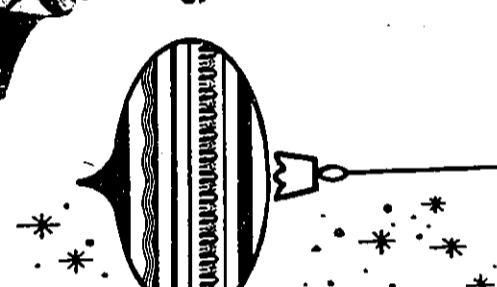

**Ornaments
and Collectables**

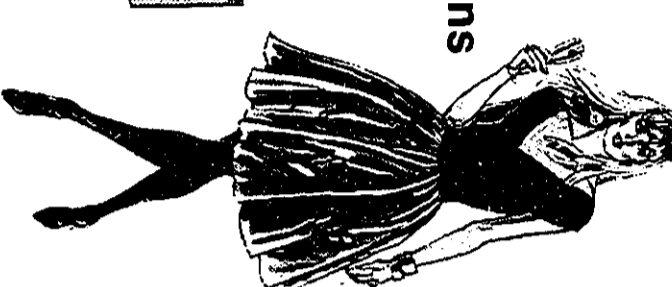

**Ladies
Fashions**

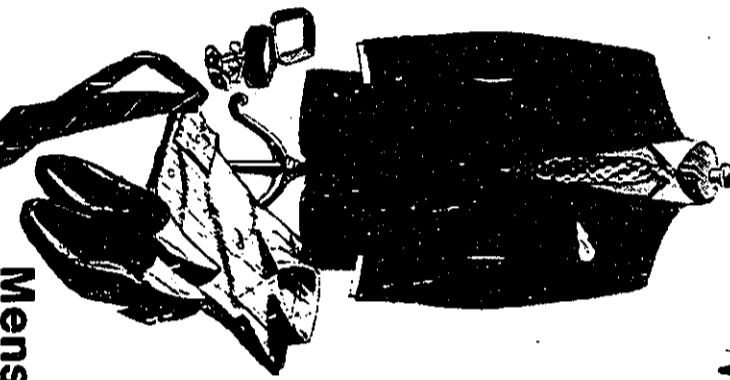

Menswear

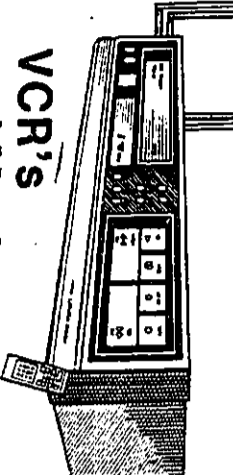

**VCR's
and Movies**

One Stop Christmas Shopping - Something For Everyone On Your List!



SANDICAST
Animal Sculptures

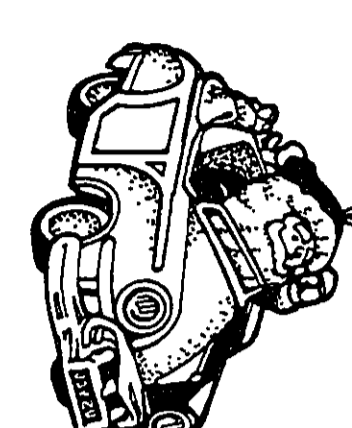

Hallmark
Ornaments

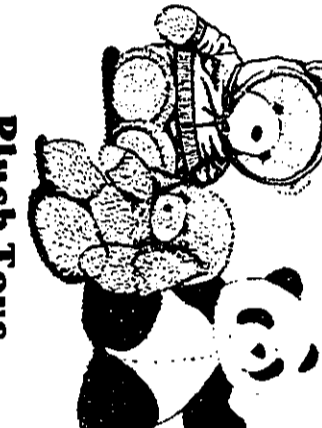

Plush Toys
Enchanting



**Teddy
Bears**
Arant



Russell Stover
CANDIES



Card & Gift Center

Our expert sales staff is ready to assist you with a polypourt of helpful suggestions. See us soon while selections are best

478-3871 Your *Hallmark* Headquarters **Sunday 12-5**

Daily 9:30-9

LAST MONTH WE GAVE EVERYONE A NEW REASON TO SMILE.



WE OPENED OUR NEWEST BORICS

Last month, we cut more than hair. We cut the grand opening ribbon of the latest addition to BoRics Haircare Salons. The great place to get a great haircut for just \$6.

Our trained professionals will give you a quality haircut. They'll wet down your hair with a special cutting solution, cut it the way you want and blow it dry.

Clean hair is necessary for accurate hair cutting. You can shampoo your hair on the day of your visit, or, for a small charge, we'll shampoo it for you. Because, at BoRics, you pay only for the services you need.

You can't beat BoRics for convenience, either. No appointments are necessary. Just walk into one of our convenient locations Monday through Friday 9 a.m. to 9 p.m., or Saturday 9 a.m. to 6 p.m.

Don't settle for the uninteresting styles of a barbershop or the high prices of a beauty salon. Stop into BoRics and let us give you a new reason to smile, too.

*Mall hours may vary

\$6

FOR A GREAT HAIRCUT.
Over 150 locations in the U.S. and Canada.

\$1 OFF HAIRCUTS

Get \$1 off our everyday low \$6 haircut price. Coupon valid at any BoRics location. No appointment necessary.

\$6 OFF PERMS

Get \$6 off our regular perm price (\$32 short hair, \$37 medium hair, \$42 long hair). Includes shampoo, cut and style. Coupon valid at any BoRics location. Appointment recommended for perms.

New Location
FARMINGTON
37085 Grand River
at Halstead
Grand River/Halstead Center
Phone: 471-0880



OPENING SOON: WEST OAKS II
12 Mile & Novi Rds.

OTHER LOCATIONS

LIVONIA
19592 Middlebelt Rd.
at 7 Mile Rd.
Across from Livonia Mall
Phone: 471-5777

LIVONIA
37460 5 Mile Rd.
at Newburg
Across from Farmer Jack
Phone: 464-4144

FARMINGTON HILLS
29308 Orchard Lk. Rd.
at 13 Mile Rd.
Beside 7-11
Phone: 626-4775



B 100% Retailer
for the Year

BUILDERS SQUARE
HOME IMPROVEMENT WAREHOUSE

HOLIDAY

FIX-UP SALE

WE WILL
BE CLOSED ON
Thanksgiving

AMERICA'S LARGEST HOME IMPROVEMENT WAREHOUSE!

NOVEMBER SALE DATES

SUN	MON	TUE	WED	THU	FRI	SAT
			18	19	20	21
22	23	24	25			

PERMA-BILT HIGHLANDER VANITY

\$29

17" x 19" #Y1109

- White with gold trim.
- Includes quality cultured marble top.

STUDENT DESK

\$34

- Hinged door storage area.
- Timberland finish.
- 29" H x 36-7/8" W x 15-5/8" D
- Tough stain and scuff-resistant finish.

Glidden Exclusive paint sponsor, ABC telecasts, Winter Olympic Games

3200 SERIES
SPRED WALL PAINT

493
PER GALLON

- Latex flat interior paint.
- Durable, quick drying finish.
- Easy clean-up with soap and water.
- Completely washable.



FREE PAINT MIXING!
OVER 2,000 DIFFERENT COLORS

8" x 24" SHELVING

249 EA.

AVAILABLE IN WALNUT, PECAN, OR WHITE

- Obtain extra storage space in any room.
- Standards and brackets available.

4-FOOT SHOPLIGHT

#SL240K

850

PERFECT FOR GARAGES!

- A must for any shop.
- Grounded cord.
- Light bulbs not included.

GYPSUM BOARD

396 PER SHEET

1/2" x 4' x 8'

TURN THIS PAGE FOR MORE VALUES!



YOUR ONE-STOP LUMBER SHOP!

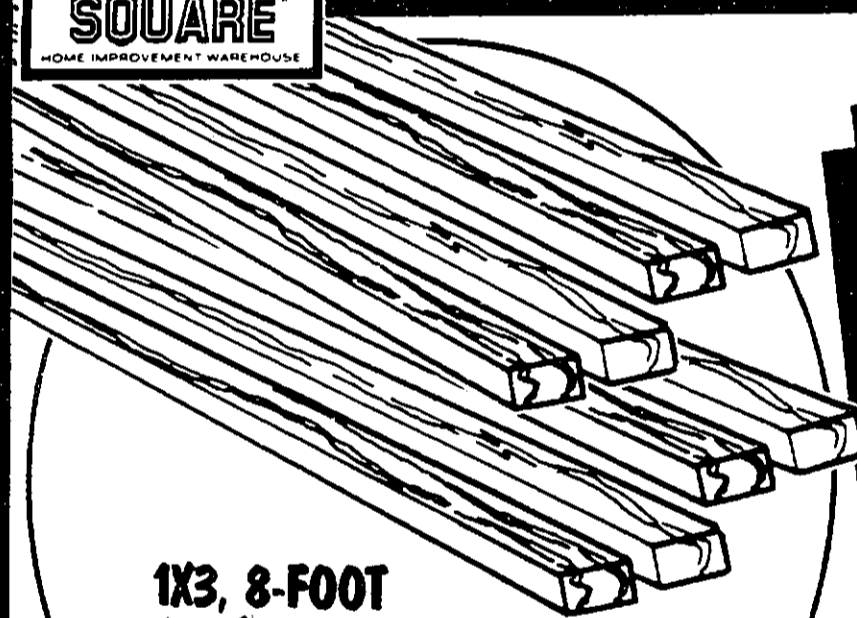

1X3, 8-FOOT
WHITWOOD
FURRING
STRIPS

66¢ EACH

MERCHANDISE LOADING

Our stores are designed for easy access to goods, with plenty of space to maneuver. But, if you are a staff of one, or just need that extra hand, take advantage of our free load-up service.

ZIP ORDERING SERVICE

If you have a large order, give us a call, tell us your needs and we'll have it ready and waiting for you within 3 hours.

GREAT BUY!

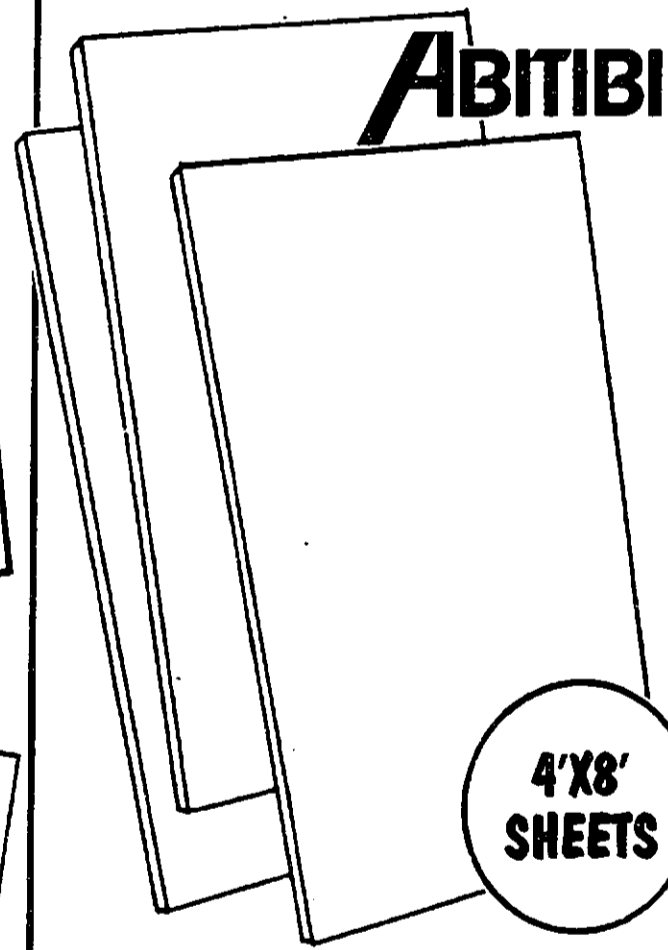

4'X8'
SHEETS

TILE BOARD PANELS **998**

WHITE OR
ALMOND

AGEAN GOLD	DESERT OR SILVER MIST	SAND PEBBLE OR BLUEWATER REEF	CORALINE ROSETTE
13.34	17.59	19.48	23.16

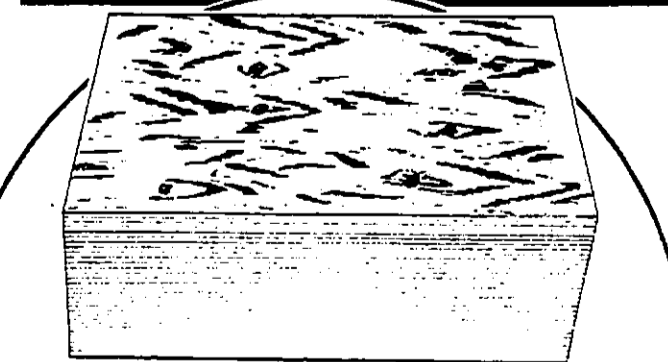

1/4" BC SANDED PLYWOOD **894**

4'X8'

A versatile sanded plywood at an affordable price.	
Plugged and sanded for smooth finish.	
3/8"	11.39
1/2"	13.58
3/4"	15.99

TOP QUALITY—SUPER PRICE!



MASONITE PANELING

- Light, durable and warp-resistant.
- Long-life value.
- Easy to install.

WHITE WEATHERED BARNSTABLE	CHESTNUT	RED BRICK
12.59	13.87	17.72

1093

• DURHAM
OAK

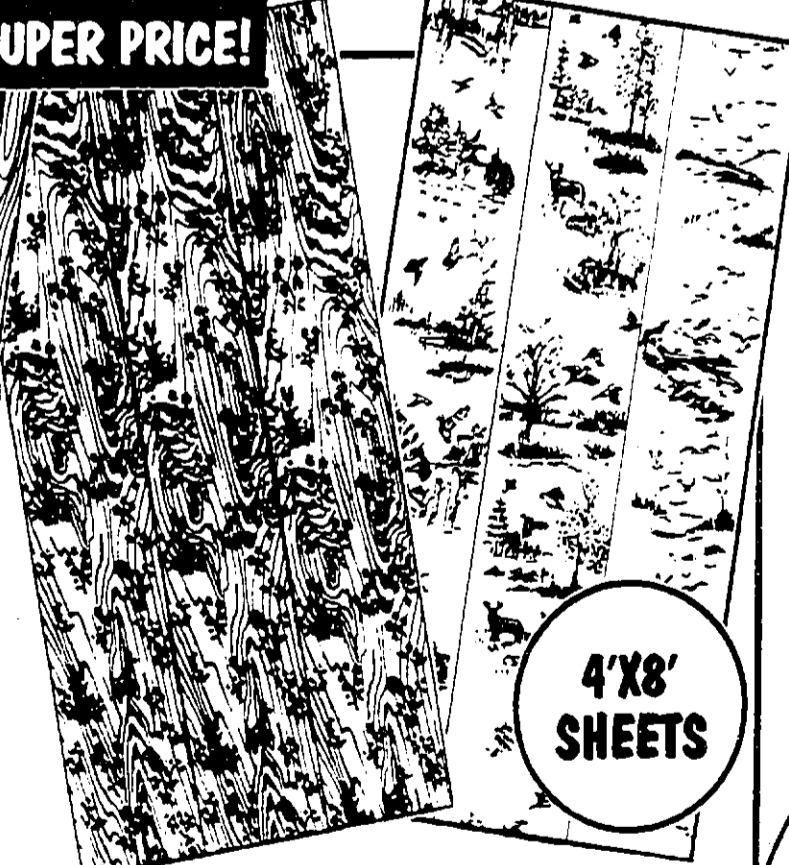

DECORATOR PANELING

- Lightweight, durable paneling.
- An alternative to wallpaper and paint.
- High quality wall treatments in a variety of textures and designs.
- Maintenance free, prefinished for long life.

CARRIAGE HOUSE	1323
COLONIAL MANOR	
AUTUMN HARVEST	

1278

- NATURE'S
WOOD
- MAYFLOWER

YOU'LL BE FLOORED WHEN YOU SEE OUR LOW PRICES!

Armstrong FLOOR TILE

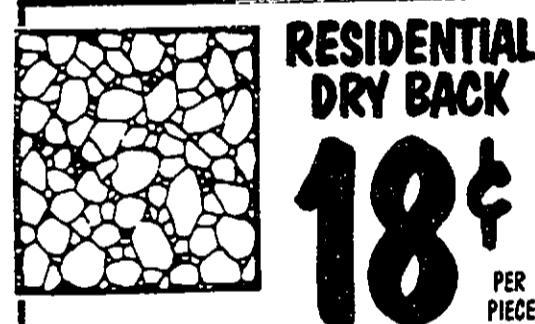

RESIDENTIAL DRY BACK **18¢**

PER
PIECE
• Measures 12"x12"
• Sold in cartons of 45.
CARTON **8.10**

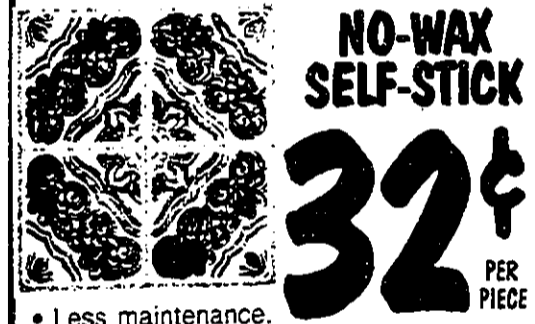

NO-WAX SELF-STICK **32¢**

PER
PIECE
• Less maintenance.
• Easy to clean and care for.
• Self-adhering for easy installation.
• Sold in cartons of 45.
CARTON **14.40**

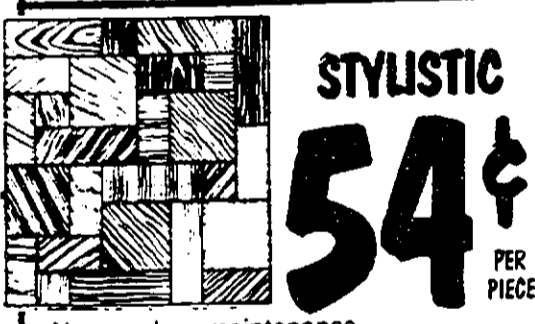

STYLISTIC **54¢**

PER
PIECE
• No-wax, less maintenance.
• Heavy-duty wear surface, easy to clean.
• Self-stick for quick installation.
• Sold in cartons of 45.
CARTON **24.30**



SOLARIAN **72¢**

PER
PIECE
• High shine, no-wax embossed surface.
• Heavy-duty vinyl structure.
• Self-stick for quick installation.
• Sold in cartons of 45.
CARTON **32.40**

OAK HARDWOOD FLOORING



PARQUET **196**

SQ. FT. CARTON OF
20 SQ. FT. **39.20**

PLANKING **296**

SQ. FT. CARTON OF
20 SQ. FT. **59.20**

- Dura-finish - easy care, easy clean.
- Tongue and groove for easy installation.
- Stain resistant, easy care.
- All necessary moulding and reducing strips available.
- Sold in full cartons only.

Armstrong ROLL VINYL FLOORING

BRISTOL **224**

SQ. YD.
2.99 LN. FT.

ROYELLE **296**

SQ. YD.
3.95 LN. FT.

CAMBRAY **450**

SQ. YD.
6 LN. FT.

- No wax - less work.
- 30% thicker than Royelle.
- Protected against mold.

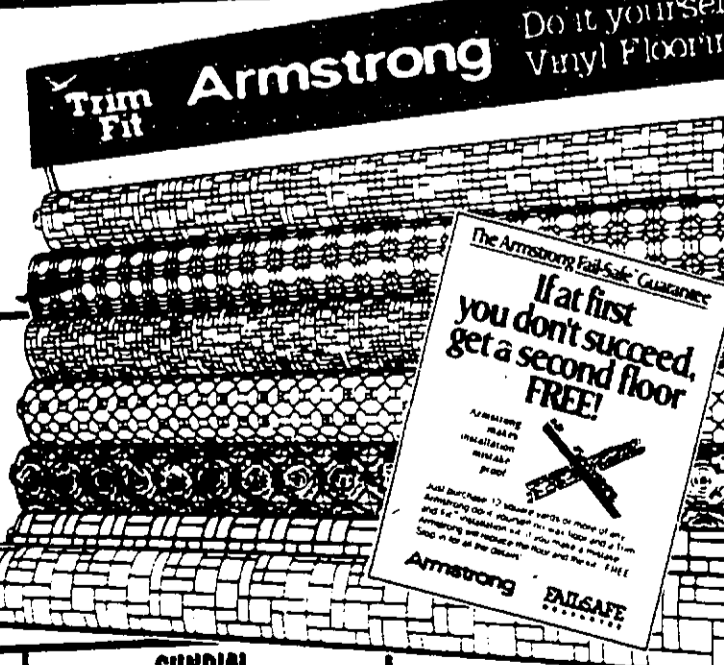

Trim Fit
Do it yourself
Vinyl Flooring

If at first
you don't succeed,
get a second floor,
FREE!

SUNDIAL SOLARIAN **825**

SQ. YD.
11 LN. FT.

- Urethane mira-bond XL wear surface.

TRIM AND FIT KIT **496**

2800

CARPETING

WALL STREET **372**

SQ. YD.
4.96 LN. FT.

- 100% Olefin level loop cushion back.
- Stain resistant, easy care.
- Easy to install.

STATE STREET **442**

SQ. YD.
5.90 LN. FT.

- Attached cushion back.
- Easy to install.
- 12 foot width.

BROADWAY **596**

SQ. YD.
7.94 LN. FT.

- 100% continuous filament nylon.
- Attached cushion back.

FIFTH AVENUE **646**

SQ. YD.
8.61 LN. FT.

- 100% continuous filament nylon.



WE'VE GOT IT ALL!

- SELECTION
- SERVICE
- SAVINGS



1/2" PVC MINI BLINDS
WHITE OR IVORY
496
EACH
23" X 42"

NOT ALL SIZES AVAILABLE IN ALL STORES.

* Includes all necessary hardware.

WxL	PVC		WOOD	
	1/2"	1"	1"	1"
23x42	4.96	7.96	14.84	
23x54	6.96	11.96	22.86	
27x54	7.96	13.96	24.92	
29x54	8.46	15.96	27.33	
35x54	8.96	16.46	29.47	
36x54	9.96	16.96	30.67	
35x64	10.46	17.96	32.27	
36x64	10.96	18.96	34.31	
42x64	12.96	19.96	36.91	
46x64	13.96	21.96	39.22	
47x64	13.96	22.46	42.46	
48x64	14.96	24.96	45.22	
60x64	15.96	28.96	53.08	
72x64	17.96	32.96	58.72	

WHILE QUANTITIES LAST

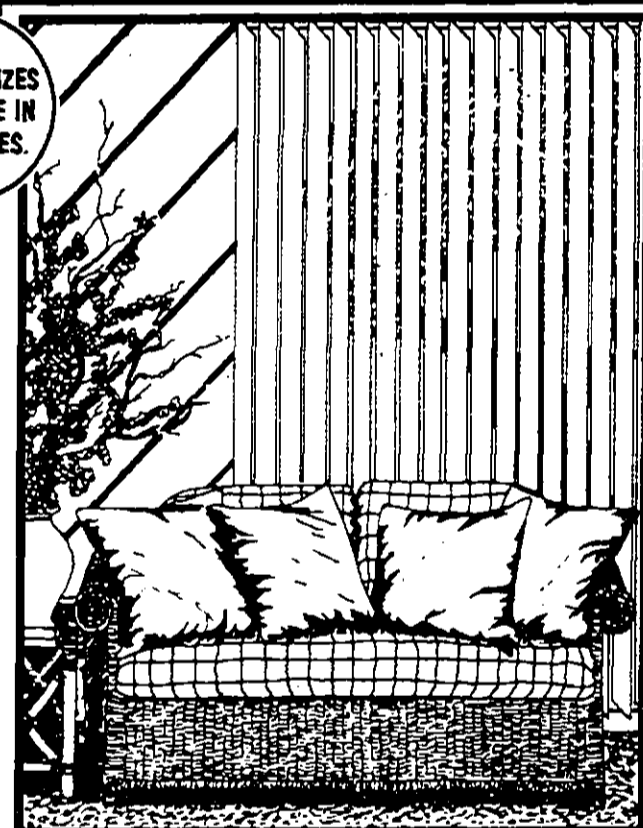

VERTICAL BLINDS
WHITE OR ALABASTER

\$42
63" X 84"

* Easy to care, easy to clean blinds. Provides privacy.

HEIGHT	WIDTH			
	72-INCH	78-INCH	85-INCH	104-INCH
84-INCH	\$49	\$54	\$59	\$69

DORFILE
STORAGE & SHELVING SYSTEMS

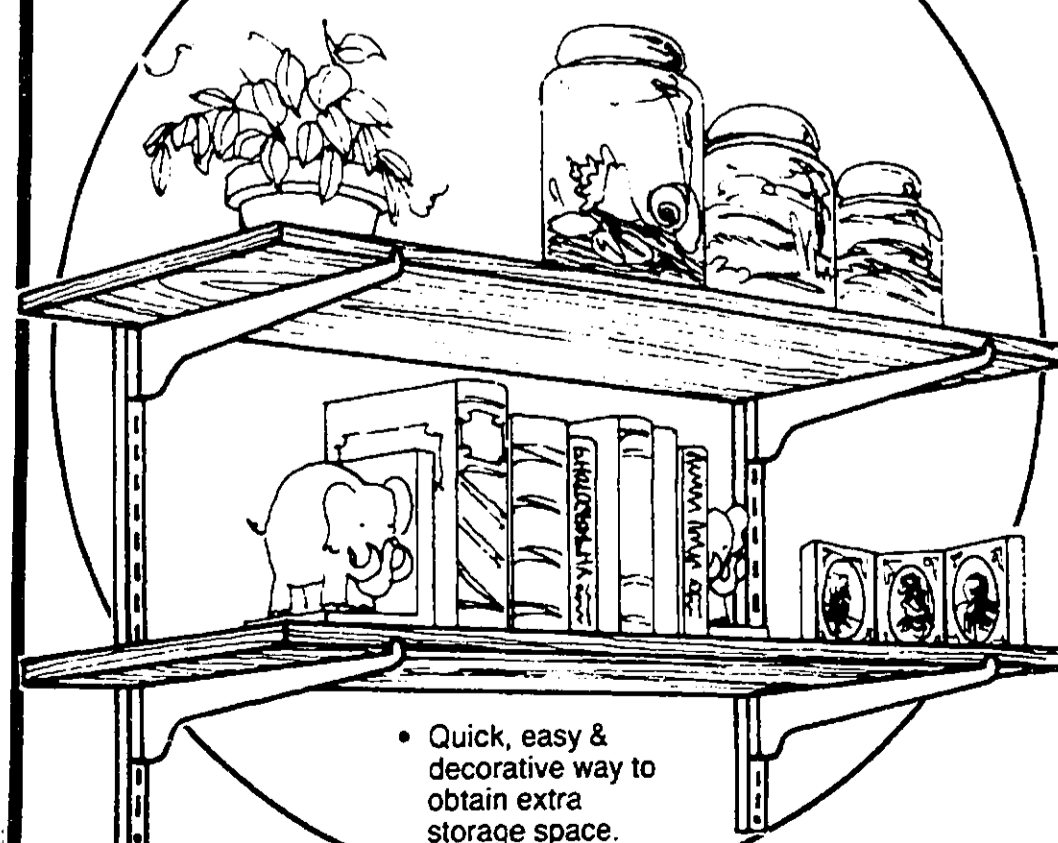

* Quick, easy & decorative way to obtain extra storage space.

PRE-FINISHED SHELVING

L	W	8"	10"	12"
24"	2'9"	4 ⁶⁹	5 ⁷³	
36"	4 ⁴⁶	6 ³⁴	7 ¹⁶	
48"	6 ⁵⁴	8 ¹⁷	9 ⁴⁸	

* Solid wood shelving, walnut, pecan or white.

READY-TO-FINISH

LAUAN	8" W	10"	12"
24" L	1.49	2.96	3.07
36"	2.66	3.90	3.99
48"	4.15	5.24	5.35

OAK	8" W	10"	12"
24" L	2.96	—	—
36"	3.68	6.92	7.44
48"	4.87	—	8.76

STANDARDS

	1 FT.	2 FT.	3 FT.	4 FT.
GOLD, WALNUT, WHITE	1.33	1.96	2.49	3.33
PECAN	1.43	2.39	3.66	4.92
CHARCOAL	1.43	2.39	3.66	4.92
BRASS	1.35	1.61	2.33	3.16
ANTIQUE BRASS/BRONZE	1.46	1.72	2.44	3.27
UTILITY	—	.92	—	1.85

BRACKETS

	8"	10"	12"
GOLD, WALNUT, WHITE	1.33	1.45	1.58
PECAN	1.78	1.96	2.16
CHARCOAL	1.78	1.96	2.16
ANTIQUE BRASS/BRONZE	1.62	1.73	1.84
BRASS	1.51	1.62	1.73
UTILITY	.78	.91	1.05

THE LOWEST PRICES... THE LARGEST SELECTION!

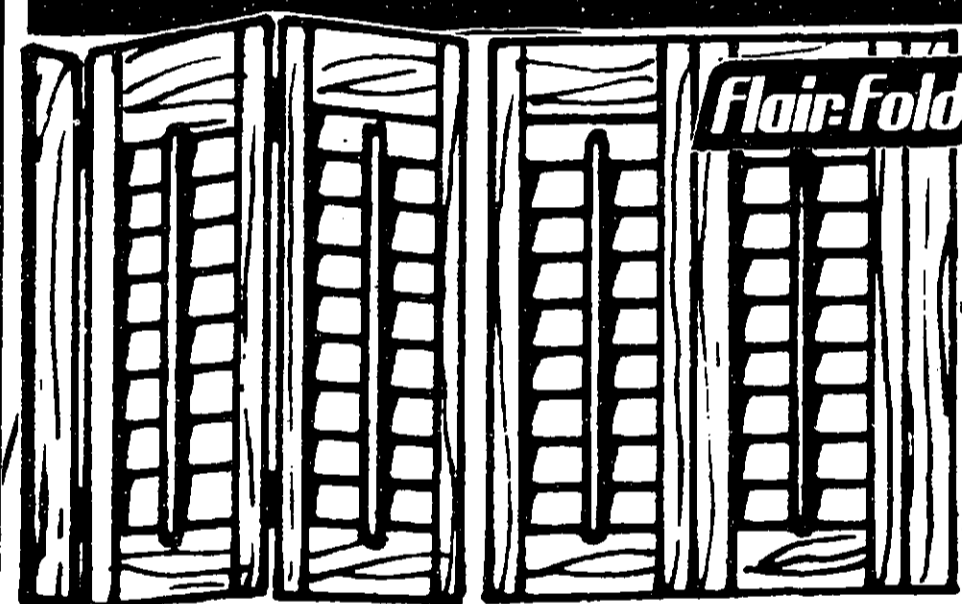

READY-TO-FINISH LOUVER SHUTTER PANELS

- * Pine shutters with moveable louvers.
- * Ready to paint or stain.

H	16"	20"	24"	28"	32"	36"
6"	1.47	1.96	2.47	2.98	3.43	3.96
7"	1.96	2.47	2.98	3.56	3.91	4.63
8"	2.44	3.94	3.47	3.97	4.98	4.98
9"	2.92	3.43	3.93	4.54	4.93	5.49
10"	3.22	3.78	4.28	4.81	5.37	5.86
11"	3.57	4.07	4.62	5.16	5.67	6.72
12"	3.58	4.66	5.16	5.73	6.27	7.88

TOP QUALITY—SUPER PRICE

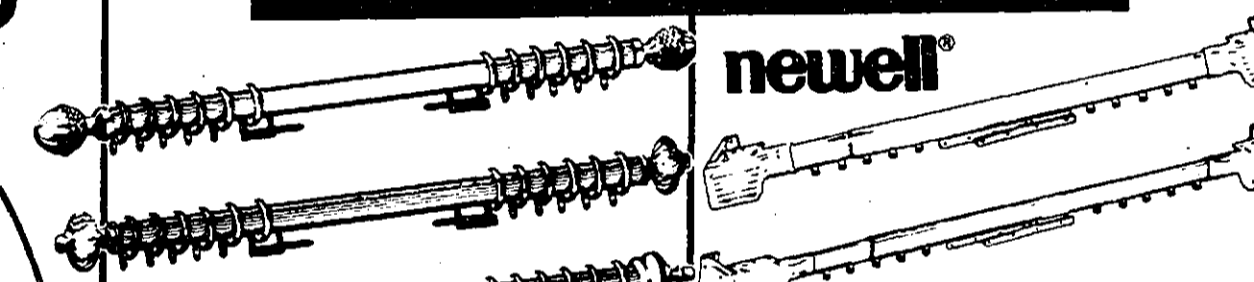

AVAILABLE IN ANTIQUE BRASS, DARK WOOD OR LIGHT WOOD
DECORATIVE TRAVERSE RODS
996
EACH
1" X 30"-50" LONG
* Add elegance to any decor.

1" X 50"-86" LONG	1396	EACH
1-3/8" X 30"-50" LONG	1496	EACH
1" X 84"-150" LONG	2196	EACH
1-3/8" X 50"-86" LONG	2296	EACH
1-3/8" X 84"-150" LONG	3196	EACH

WHITE TRAVERSE RODS
427
EACH
29" X 48"
* Ready to hang
* Hardware included

LIGHT DUTY CENTER PULL	48"-84"	558
	66"-120"	746

REGULAR DUTY	TRAVERSE ROD SHEER
30"-50"	536
48"-86"	837
84"-150"	1176
30"-48"	894
48"-86"	1158
66"-120"	1424

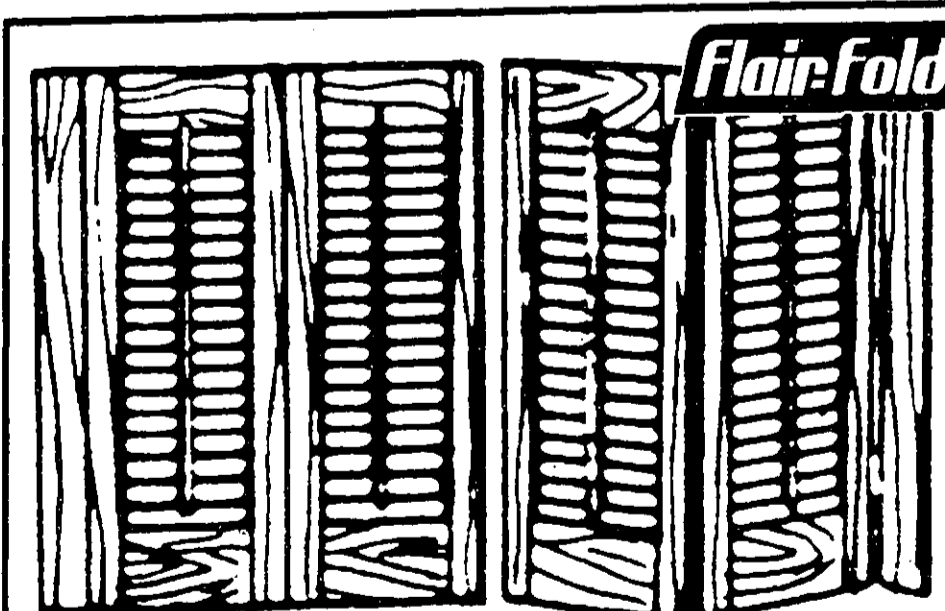

PRE-FINISHED LOUVER SHUTTER KITS

- * Beautiful walnut finish.
- * Hardware included.

HEIGHT OF OPENING	WIDTH OF OPENING			
	25" to 29"	29" to 33"	33" to 37"	37" to 41"
7 1/4" to 20 1/4"	'19	'22	'26	'29
21 1/4" to 24 1/4"	'26	'28	'28	'31
25 1/4" to 28 1/4"	'29	'30	'34	'36
29 1/4" to 32 1/4"	'34	'33	'38	'40
33 1/4" to 36 1/4"	'38	'37	'40	'44

WINDOW SHADES

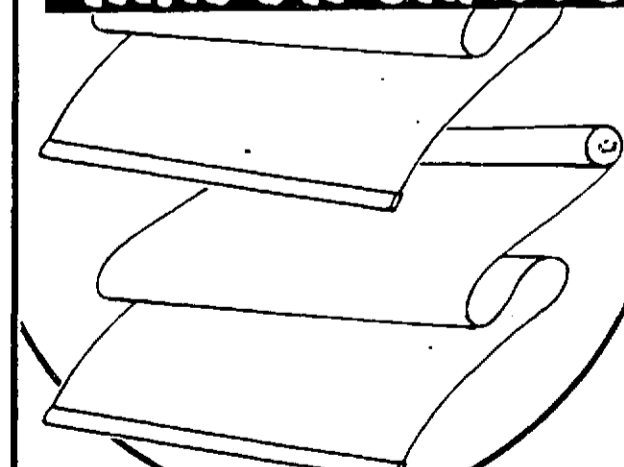

39-INCH WHITE OR EGGSHELL LIGHT FILTERING WINDOW SHADE
296
EACH

37-INCH ROOM DARKENING WHITE OR EGGSHELL
496
EACH

37-INCH HEAVY WEIGHT LIGHT FILTERING
643
EACH
* Biscuit, white or oyster.

37-INCH ROOM DARKENING WHITE OR OYSTER
850
EACH

SIZE	LIGHT FILTERING	ROOM DARKENING
37"	496	643
46"	774	996
55"	996	1396
73"	1986	2650



POWERFUL SAVINGS ON POWER TOOLS!



6 INCH BENCH GRINDER **\$29**

- Bell-shaped housing covers 6" grinding wheels.
- Made with durable ball-bearing construction.
- Includes plastic eye shields for protection.

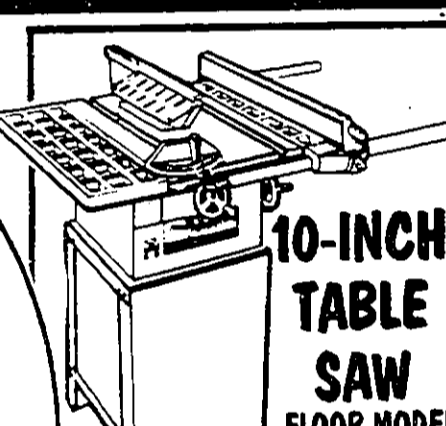

10-INCH TABLE SAW FLOOR MODEL **\$275**

- Heavy-duty cast iron table.
- 1 1/2 H.P. high torque motor.
- Aluminum extension wings.
- Self-aligning positive grip rip fence.

5-SPEED DRILL PRESS TABLE MODEL **\$79**

- 1/5 H.P., 115 volt.
- Depth gauge and adjustable work platform.

12 SPEED **\$145**
16 SPEED **\$155**

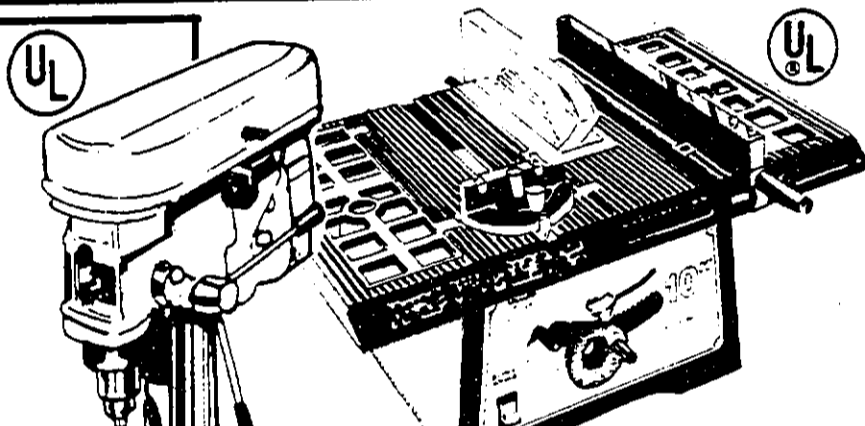

10-INCH BENCH TABLE SAW **\$79**

- Heavy duty 10" saw.
- Cuts to a maximum depth of 3-1/8".
- 2 1/2 HP motor.
- Portable.

BUY IT RIGHT AND SAVE!



1/4 HP BELT AND DISK SANDER **\$65**

- Features steel base.
- 4" x 6" belt.
- Belt tilts and locks at any position from horizontal to vertical.



WOOD LATHE **\$85**

- Four speed.
- 37" center to center.
- 12" swing.
- Cast iron tool rest.
- UL listed.

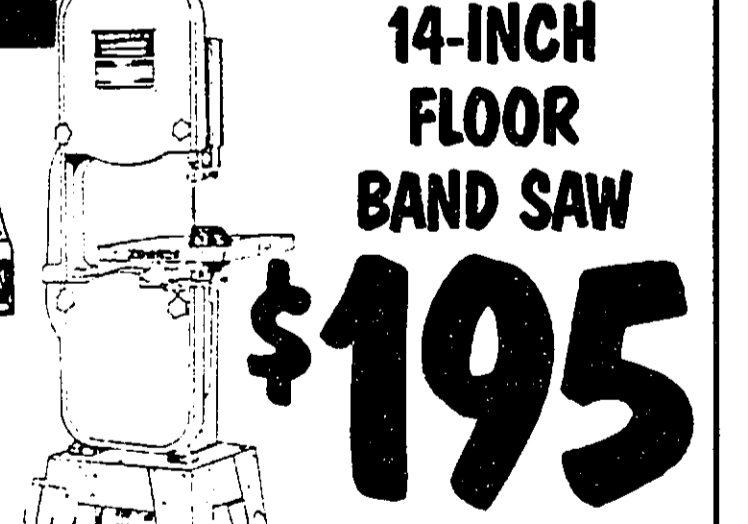

14-INCH FLOOR BAND SAW **\$195**

- 14" deep-cut woodworking band saw.
- 1/2 HP, belt-driven.

GREAT BUY!

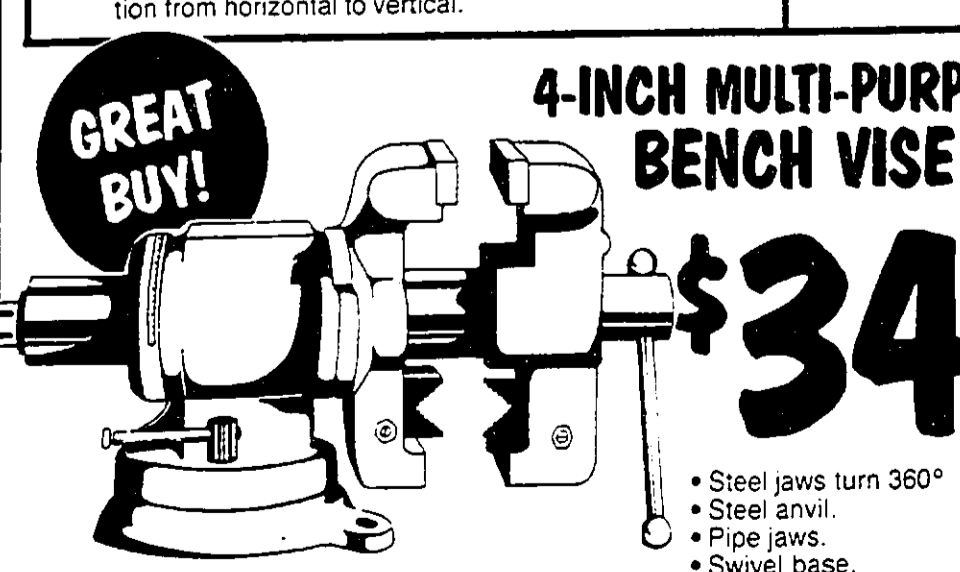

4-INCH MULTI-PURPOSE BENCH VISE **\$34**

- Steel jaws turn 360°.
- Steel anvil.
- Pipe jaws.
- Swivel base.

5" **\$46**

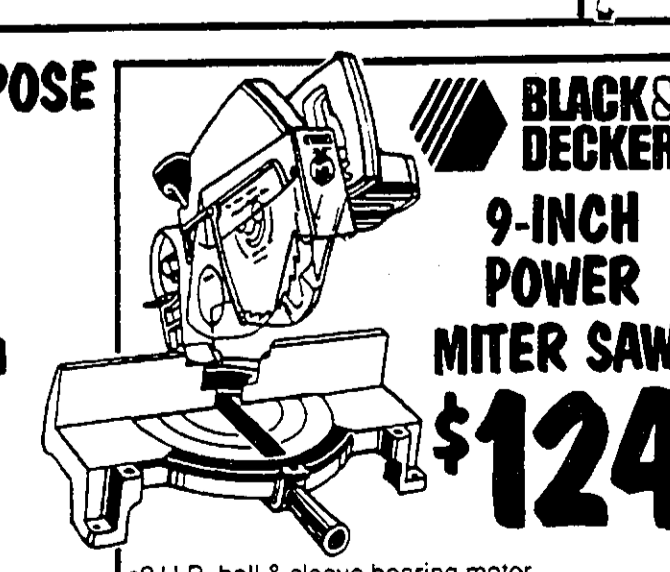

BLACK & DECKER 9-INCH POWER MITER SAW **\$124**

- 2 H.P. ball & sleeve bearing motor.
- Gear driven blade.
- Table rotates with cutting blade.
- Includes 9" combination blade and blade wrench.

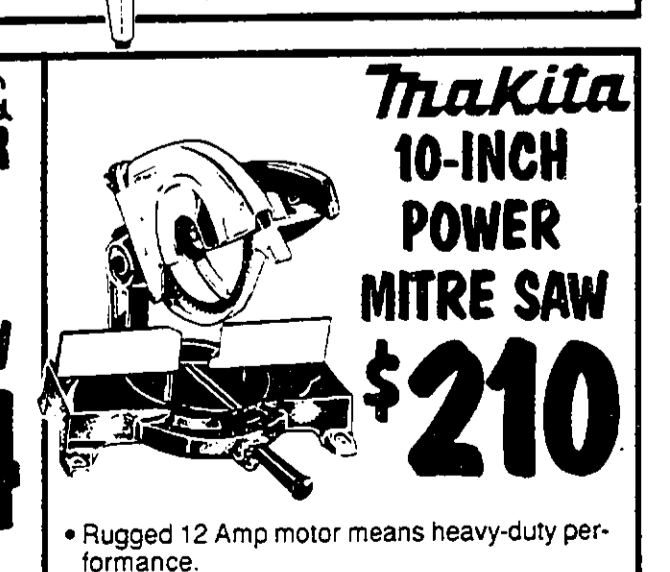

Makita 10-INCH POWER MITRE SAW **\$210**

- Rugged 12 Amp motor means heavy-duty performance.
- Solid construction plus precision cutting and braking on wood, plastic, and aluminum.
- Wrench and combination blade included.

STANLEY GARAGE DOOR OPENERS!

BUILDERS SQUARE HAS GREAT IDEAS...

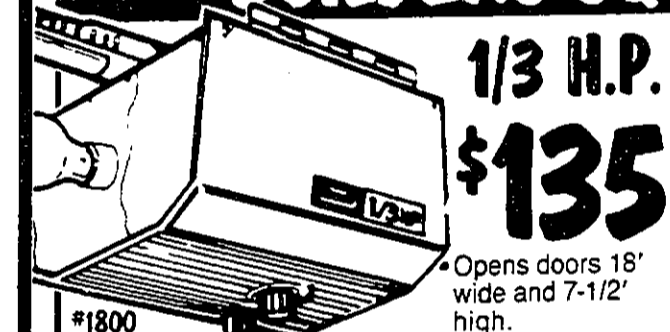

1/3 H.P. **\$135**

- Opens doors 18' wide and 7-1/2' high.

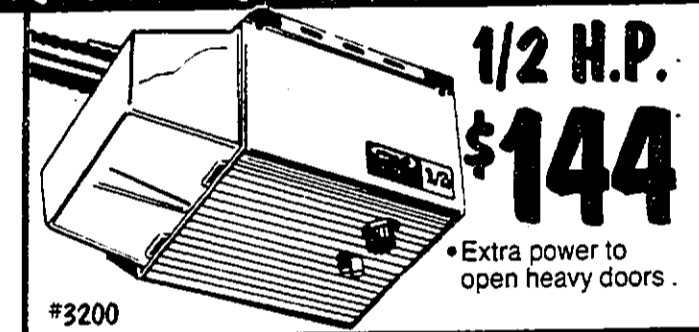

1/2 H.P. **\$144**

- Extra power to open heavy doors.

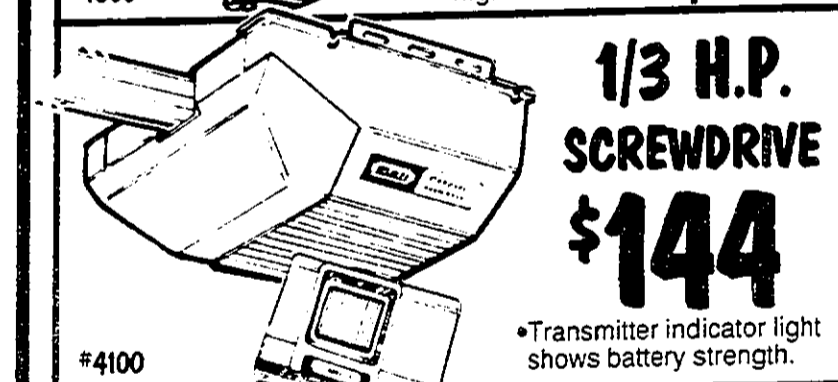

1/3 H.P. SCREWDRIVE **\$144**

- Transmitter indicator light shows battery strength.

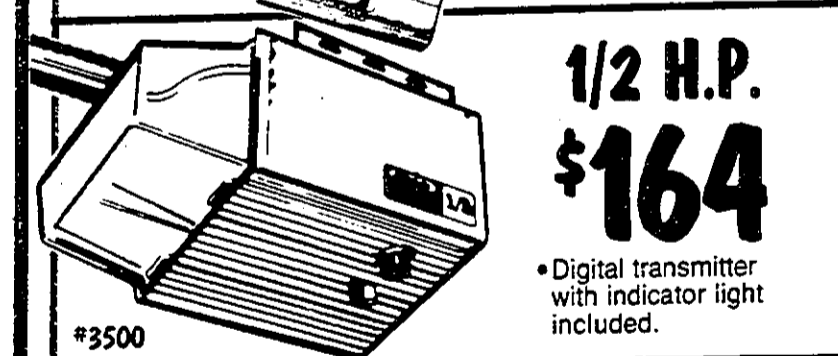

1/2 H.P. **\$164**

- Digital transmitter with indicator light included.

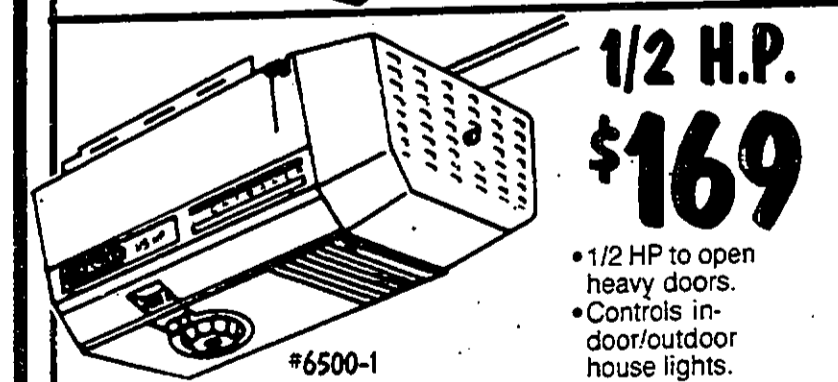

1/2 H.P. **\$169**

- 1/2 HP to open heavy doors.
- Controls in-door/outdoor house lights.

Enter the Stanley

You're The Winner

Extravaganza Sweepstakes



Win a 1988 Oldsmobile Cutlass Ciera. We're giving away 10 of 'em.

Purchase a Stanley LIGHTMAKER™ garage door opener and get a FREE* extra transmitter direct from Stanley. See store for details.

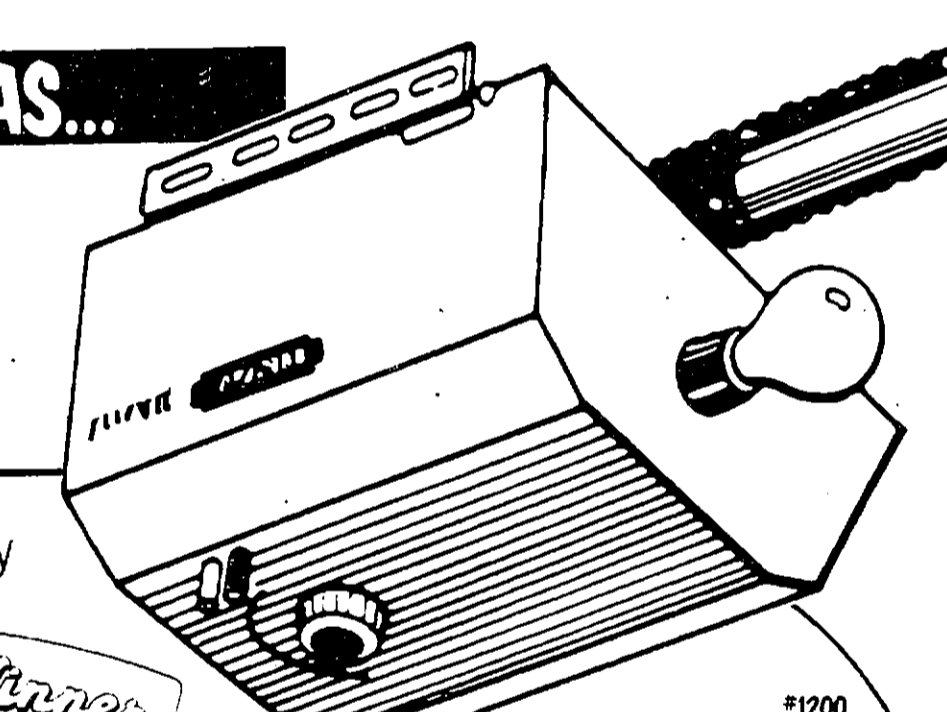

1/4 H.P. CHAIN DRIVE **\$87**

- Chain drive with 1 digital transmitter.
- Automatic on/off light on open and close.

INSTALL IT! GARAGE DOOR OPENER **\$85**

LABOR ONLY! FOR NORMAL INSTALLATION and it's GUARANTEED!

TRANSMITTERS AND ACCESSORIES



STANLEY LAMP MODULE **\$17**

- Turns lamp on and off by remote control.
- Can dim and brighten lights.



STANLEY ELECTRIC KEY SWITCH **1064**

- Installs in minutes, all wires and hardware included for installation.



STANLEY DIGITAL KEYLESS ENTRY **3788**

- Open garage door from outside without transmitter or key.

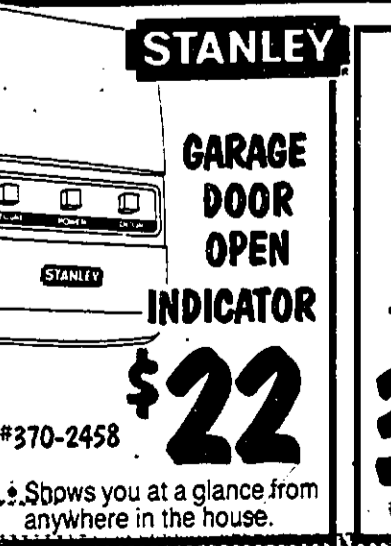

STANLEY GARAGE DOOR OPEN INDICATOR **\$22**

- Shows you at a glance from anywhere in the house.

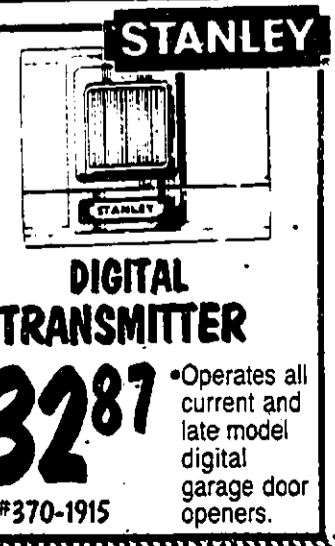

STANLEY DIGITAL TRANSMITTER **3287**

- Operates all current and late model digital garage door openers.

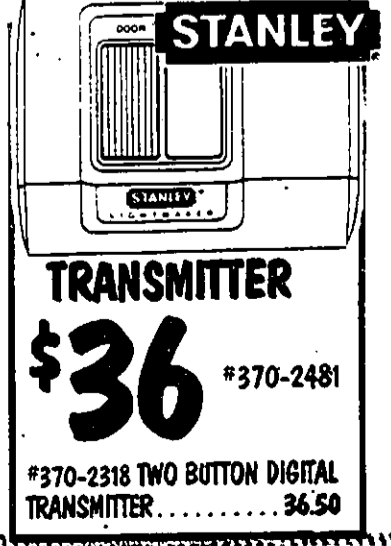

STANLEY TRANSMITTER **\$36**

- #370-2481
- #370-2318 TWO BUTTON DIGITAL TRANSMITTER... 36.50

"CEILING FAN BLOW-OUT"



48-INCH 3-SPEED SUMMER BREEZE
 #2241, #2242, #2243
\$63
 • Real wood blades and motor housing enhanced with designer touches.
 • Has electrically reversible motor with special noise reducers.



52-INCH 3-SPEED BIARRITZ
 #23023
\$73
 • Designed exclusively for Builder's Square by Hunter

52" 3-SPEED BIARRITZ LO-PROFILE
 #25572, #25606
\$77
 • Custom designed 3-speed, electrically-reversible motor.
 • Real wood blades.
 • Metal motor housing.
 • Available in antique brass, polished brass or white.

52-INCH 3-SPEED ORIGINAL
 #25572, #25606
\$133
 • Electrically reversible, pre-balanced and pre-assembled blades.



INSTALL IT! CEILING FANS
 Labor only!
\$40
 ON STANDARD LIGHT FIXTURE REPLACEMENTS
 FOR NORMAL INSTALLATION
 and it's **GUARANTEED!**

FACTORY DIRECT SAVINGS!



42" SCANDIA CEILING FAN
 #K530, #A8-88
\$30
 • 4 stenciled wood blades
 • Lighted glass motor housing
 • Built-in 3 speed control with reversible motor
 • Light kit adaptable



52-INCH SCANDIA
 #K530, #A8-88
\$35
 • 4 cane insert wood blades
 • Lighted glass motor housing
 • Built-in 3 speed control with reversible motor
 • Light kit adaptable
 • Ball type hanging kit

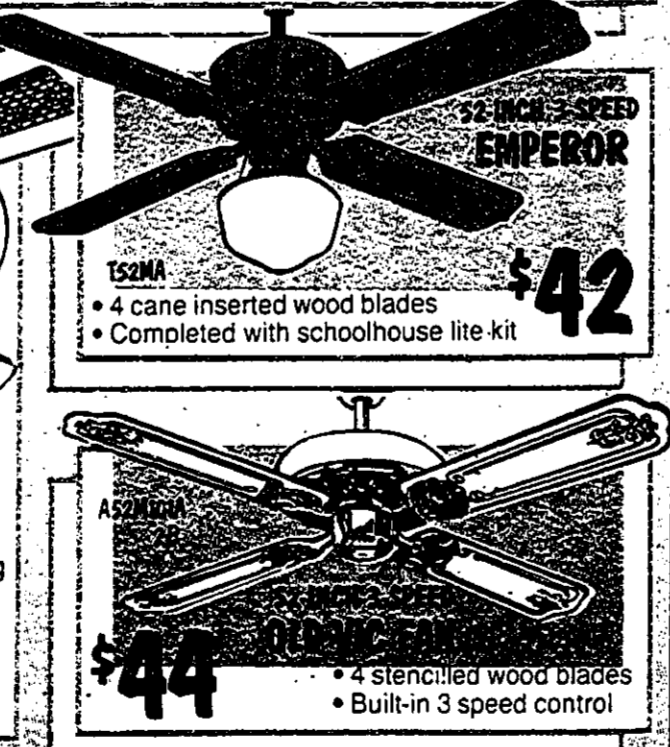

42" 3-SPEED EMPEROR
 #T52MA
\$42
 • 4 cane inserted wood blades
 • Completed with schoolhouse lite kit

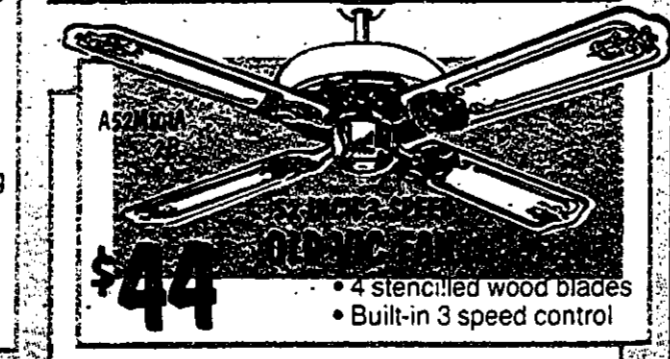

42" SCANDIA
 #K530, #A8-88
\$44
 • 4 stenciled wood blades
 • Built-in 3 speed control

CEILING FAN LIGHT KITS



5-LIGHT CRYSTAL
 #K530, #A8-88
\$20
 • Decorative etched design
 • Easy to install
 • With on/off switch

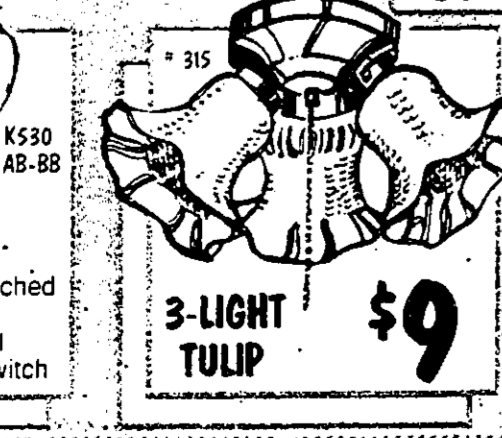

3-LIGHT TULIP
 #315
\$9

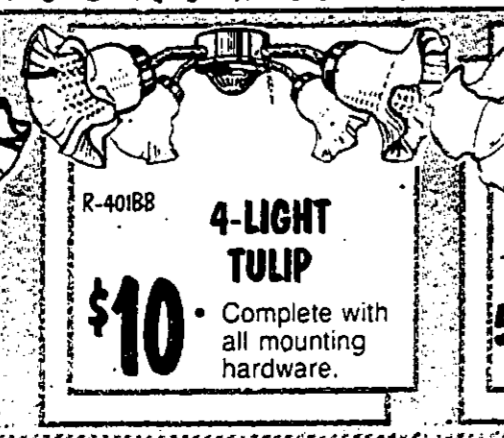

4-LIGHT TULIP
 #R-4018B
\$10
 • Complete with all mounting hardware.

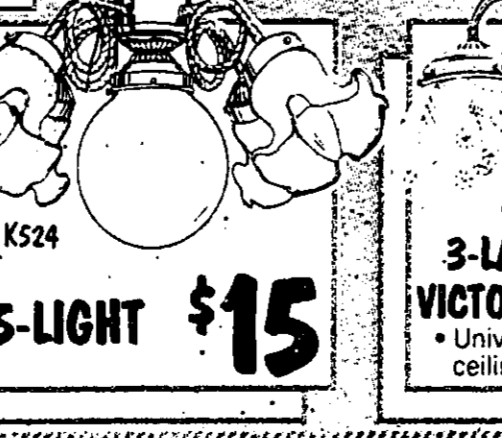

5-LIGHT
 #K524
\$15



3-LAMP VICTORIAN
 #K524
\$19
 • Universal fit for ceiling fans.

BRIGHT IDEAS



16-INCH TIFFANY LAMP
 #440 WHITE/MAIVE
\$44
 • Hand-crafted leaded stained glass fixture made in USA.
 • Porcelain light socket.



16-INCH TIFFANY LAMP
 #163
\$49
 • Available in colors to match any decor.
 #165, TIFFANY FLOWER LAMP
\$59



14-INCH TIFFANY LAMP
 #150
\$29
 • Hand-crafted leaded glass fixture, made in USA.
 • Porcelain light socket.
 • 15" diameter, 11" high.



18-INCH TIFFANY LAMP
 #183
\$59
 • Handmade leaded glass fixtures.



5-LIGHT CHANDELIER
 #DY6348
\$35
 • Beautiful polished brass finish.
 • Uses 5, 60-watt bulbs (not included).

BUY WHERE THE BUILDERS BUY!



HOME-VUE FLUORESCENTS
OAK ENDS
48", 2-LIGHT 40-WATT WRAPAROUND
\$28
 #3223/2
 • These decorative home styled ceiling lights are ideal for room remodeling.

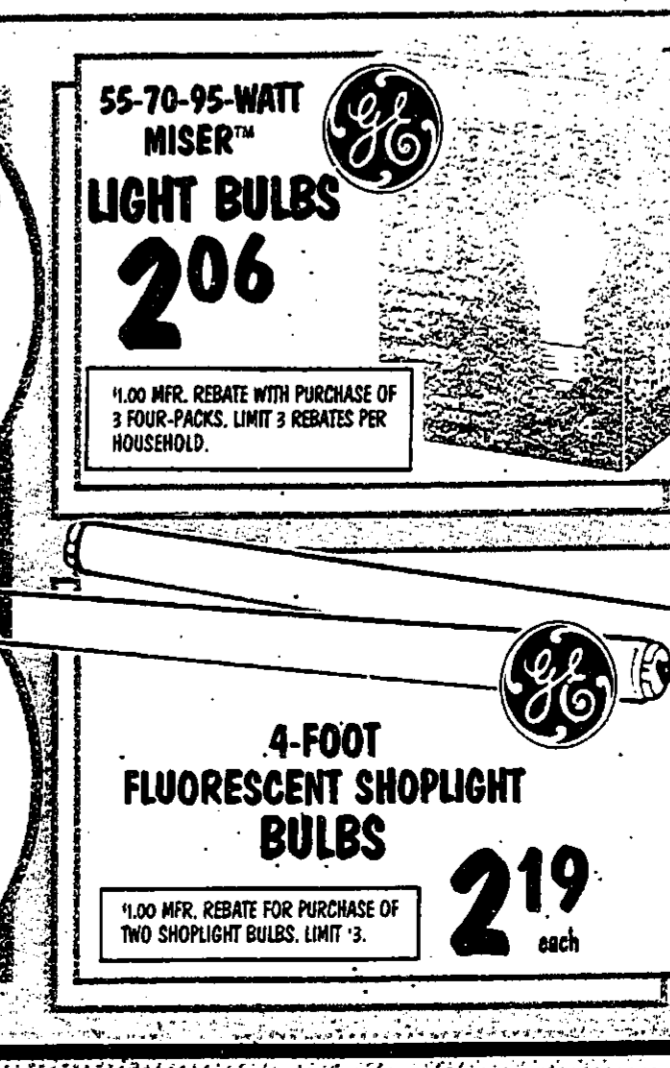

55-70-95-WATT MISER™ LIGHT BULBS
206
 \$1.00 MFR. REBATE WITH PURCHASE OF 3 FOUR-PACKS. LIMIT 3 REBATES PER HOUSEHOLD.



75-WATT PLANT LIGHT REFLECTOR
396
 \$1.00 MFR. REBATE FOR PURCHASE OF TWO BULBS. LIMIT: 2 REBATES.



65W MISER™ FLOOD AND SPOTLIGHT
296
 \$1.00 MFR. REBATE. LIMIT: 3 REBATES PER HOUSEHOLD.

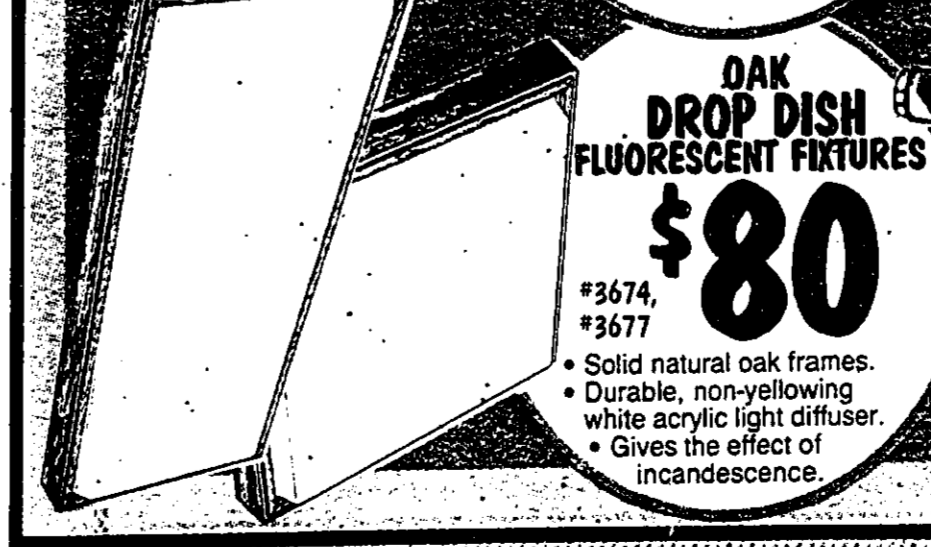

OAK DROP DISH FLUORESCENT FIXTURES
\$80
 #3674, #3677
 • Solid natural oak frames.
 • Durable, non-yellowing white acrylic light diffuser.
 • Gives the effect of incandescence.

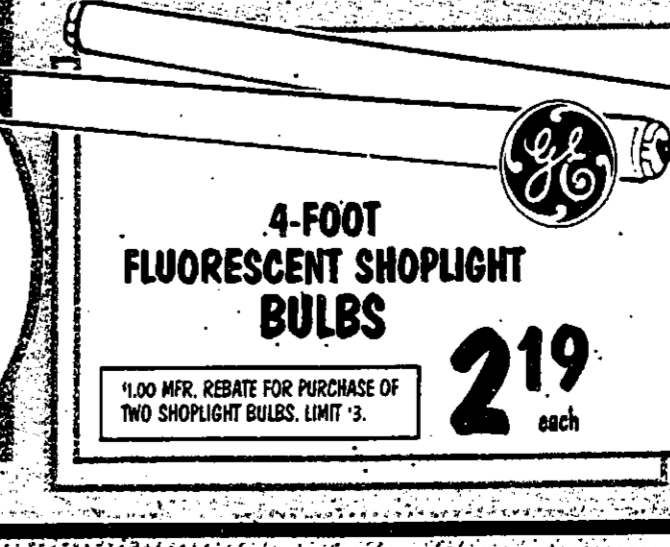

4-FOOT FLUORESCENT SHOPLIGHT BULBS
219 each
 \$1.00 MFR. REBATE FOR PURCHASE OF TWO SHOPLIGHT BULBS. LIMIT: 3.

BUILDERS SQUARE

WE'VE GOT IT ALL--- BIGGEST SELECTION, LOWEST PRICES!

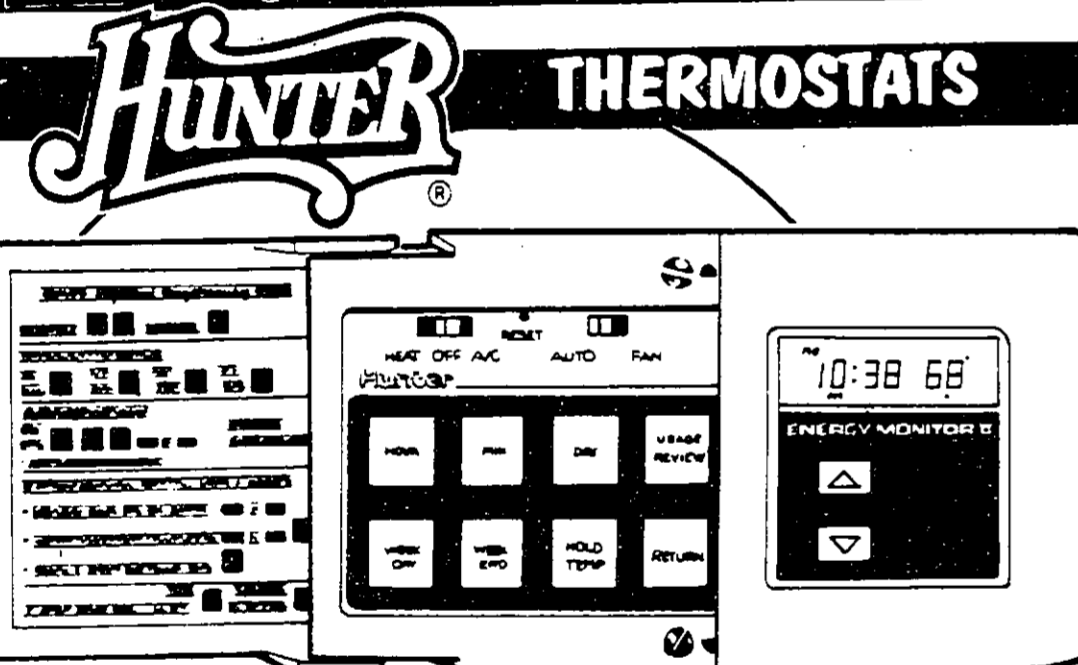

HUNTER THERMOSTATS

PROGRAMMABLE ENERGY MONITOR II
\$35

- For heating and cooling.
- Exclusive energy monitor displays energy usage in hours and minutes.
- Easy to read digital readout.
- Finger tip programming.
- Stand-by power system.

HEATER THERMOSTAT
\$9 EACH

- Horizontal or vertical mount.
- Provides accurate temperature control.
- Compatible with most gas, oil and electric systems.

ROUND HEATER THERMOSTAT
\$10

- Maintains optimum furnace/boiler cycles.
- Accurate alcohol.
- Complete installation instructions.

#42203 #40003 #40001 #40004 HEAT/COOL VERSION \$16 #40002 HEAT/COOL VERSION \$16

QUIET SWITCH 46¢
 #207-1451-CP

- Accepts up to #10 conductor-single pull.
- Combination side wire or back quick wire connections.
- Brown or ivory.

GROUNDING OUTLET 36¢
 #302-5320-CP

- Terminal screws accept up to #10 conductor.
- Brown or ivory.

SWITCH OR DUPLEX OUTLET WALL PLATES 16¢

- Standard covers in brown or ivory at a lower than standard price!

FLEXIBLE STEEL CONDUIT 22¢
 1/2" UNK. FT. ... 29¢ LF.
 3/4" ... 36¢ LF.

GROUNDING 3 OUTLET TAP 253

600 WATT FULL RANGE DIAL-ON/OFF ROTARY DIMMER 286
 #123-411

- Single pole model.
- Solid state incandescent dimmer.
- Solid state electronic circuitry design.

BRINKMANN WEATHERPROOF LANTERN 473
 #827-0550

- Rechargeable, weatherproof lantern.
- WHILE QUANTITIES LAST

100' GROUNDED EXTENSION CORD 792
 #16-35JT/269

- Heavy-duty.
- For use with power tools, electric lawnmowers, trimmers.

GROUND FAULT INTERRUPTER DUPLEX RECEPTACLE 950
 #032-6598

- Guards against electrical shock from faulty appliances.
- Indicating light.

1000 WATT ARCHITECTURAL DIMMER 1993
 #176-451

- Static free RFI suppressor.
- 1000 watt heavy duty.

ALL YOUR KITCHEN NEEDS!

neptune **STAINLESS STEEL SINKS!**

STAINLESS STEEL DOUBLE SINK 1988

- Quality 33"x22" sink.
- 5-1/2" deep bowls.
- Durable buffed satin finish.

DELUXE BAR SINK 1927

- Stainless steel polished to a satin finish.
- Completely undercoated.

SINGLE BOWL STAINLESS STEEL SINK 2188

- 25"x22" overall size.
- 6 inch deep bowl.
- Self-rimming design.
- Durable buffed finish.

HOSTESS SINK \$44

- Extra large bowl for soaking and washing.
- Small compartment for disposal.

1/3 HP GARBAGE DISPOSER #401 \$29

- Energy efficient motor.
- Heavy gauge carbon steel cutting assembly.
- Stainless steel, anti-jam swivel impellers.
- Corrosion proof.
- E-Z mounting system.

30-INCH RANGE HOODS

DUCTLESS WHITE	DUCTED WHITE	COLORS* DUCTED OR DUCTLESS
\$24	\$26	\$28

30-IN. STAINLESS STEEL DUCTED OR DUCTLESS \$44

NU-TONE ALMOND HARVEST AVOCADO

GARBAGE DISPOSERS

1/2 HP #501 \$39

- All mounting hardware included.

1/2 HP #701 \$49

- Stainless steel grind ring.

1/2 HP #801 \$69

- Two year limited factory warranty.

3/4 HP #901 \$99

- Corrosion proof grinding chamber and drain housing.

KITCHEN FAUCETS

2-HANDLE WASHERLESS 966

- Washerless—non metal.
- Fast, easy installation, corrosion free.

SINGLE HANDLE EASY HOOK-UP 2988

- Washerless, water and energy saving aerator.
- Flexible poly supply lines included.

TWIN HANDLE HI-RISER \$44

- 10 year "drip-free" warranty.



WE'VE GOT IT ALL... AT THE GUARANTEED LOWEST PRICES!

TOILETS PRICED RIGHT!

ATLANTIS WATER SAVER TOILET
 #C4401 C4305 ASSORTED COLORS \$69
\$59 WHITE
 Operates efficiently on only 3-1/2 gallons per flush.
 Round front bowl and straight front pedestal base for easy cleaning.
 Seat extra.

Artisan AEGEAN WATERMISER TOILET
 #C4451/C4350 ASSORTED COLORS \$84
\$74
 High quality fixture with insulated tank.
 Seat extra.

Artisan ANTIGUA TOILET
 #4385/4485 ASSORTED COLORS \$166
\$133
 Sleek, elongated design at an affordable price.
 Seat extra.

TURN-ON THE SAVINGS WITH THESE GREAT FAUCETS!

TWO-HANDLE LAVATORY
 #84407 5 YEAR WARRANTY
744
 Non-metallic washerless faucet.

Accent CHROME TWIN-HANDLE LAVATORY
 #208-50 MADE IN USA
947
 Cast brass underbody, triple chrome plated.
 Smoked acrylic handles.

MOEN WATER/ENERGY SAVER TWO-HANDLE LAVATORY
 #84401
1872
 Washerless
 10-Year limited warranty

MOEN SINGLE-HANDLE LAVATORY WITH EASY HOOK-UP
 #84501
2828
 Washerless
 10-Year limited warranty

DESIGNER TOILET SEAT
 Mayfair #44D ASSORTED COLORS
542
 Dial-on hinges.
 Install in seconds.
 Sculptured cover.

PADDED TOILET SEAT
 Mayfair #13D ASSORTED COLORS
728
 Add comfort to your bathroom with a soft seat.

Artisan LAVATORIES

ROUND REDONDO OR OVAL SORRENTO
 #C3950
\$39 YOUR CHOICE
 WHITE
 ASSORTED COLORS \$49
 Redondo: Classic 19" round, self-rimmed, shiny white china sink.
 Sorrento: Shiny white china oval with anti-splash rim and concealed overflow drain.

DONNER

DOUBLE ROBE HOOK #2030 **160** CHROME FINISH

BRUSH & TUMBLER HOLDER #2340 **190** CHROME FINISH

SOAP DISH #2360 **190** CHROME FINISH

PAPER HOLDER WITH PLASTIC ROLL #2080 **280** CHROME FINISH

18" TOWEL BAR #2218 **320** CHROME FINISH

TOWEL RING #2500 **290** CHROME FINISH

FRANKLIN BRASS MFG.

ROBE HOOK #1702 **687** POLISHED BRASS

BRUSH & TUMBLER HOLDER #1705 **992** POLISHED BRASS

SOAP HOLDER #1706 **992** POLISHED BRASS

18" TOWEL BAR #1718 **1466** POLISHED BRASS

PAPER HOLDER #1716 **1544** POLISHED BRASS

YOUR "PLUMB PERFECT" SAVINGS STORE

QUALITY Gaylan BATHROOM MUSTS! PERFECT FOR EVERY BUDGET

OAK VANITY BASE Gaylan
 24"x18"
\$188
 30"x18" \$233
 36"x18" \$266
 Superior construction. Solid oak drawers.
 Hand rubbed furniture finish. Top not included.

"OVER-THE-JOHN" SINGLE DOOR OAK CABINET
\$83
 "OVER-THE-JOHN" DOUBLE DOOR CABINET \$127
 Solid oak
 Furniture quality finish.

OAK & BRASS LIGHT STRIP Gaylan
 24-INCH \$68
 30-INCH \$78
 36-INCH \$94
 Solid construction.
 French glass globes
 100 watt capacity ceramic sockets

OAK TRI-VIEW MEDICINE CABINET Gaylan
 36-INCH \$164
 30-INCH \$177
 Hand rubbed finish.
 Oak frame tri-view beveled mirrors.

OAK FRAME MIRROR Gaylan
 30-INCH \$66
 36-INCH \$74
 Quality beveled. It creates unique look.
 Hand rubbed oak frame finish.

SOLID OAK TANK COVER Gaylan
\$109
 Fits over existing tank.
 Installs in minutes.
 Matches Gaylan bath furniture.

OAK COSMETIC CABINET Gaylan
 30-INCH \$108
 36-INCH \$119
 Cosmetic cabinet to compliment your decor.
 Hand rubbed finish

OAK MEDICINE CABINET Gaylan
\$88
 Quality beveled mirror.
 Furniture quality finish.

RELAX WITH The Shower Massage™

WALL-MOUNTED SHOWER HEAD #SM-2U **1896**
 HAND-HELD SHOWERHEAD \$27.84 \$M3U
 Five shower selections to relieve everyday stress and tension • Chrome finish

DESIGNER SERIES SHOWER HEAD #SM4 **2474**
 HAND-HELD SHOWERHEAD \$32.80 \$SM4
 8 selections to help relieve tension • Chrome finish

SHOWER FIXTURES FROM alsons BEAUTIFY AND SAVE TOO!

FULL SPRAY HAND SHOWER #472 **967**
 MESSAGE \$11.67
 Fast & easy to install.

PERSONAL SHOWER #45PK **2240**
 2 showers in 1-stationary and moveable.

CLASSIC STYLE FULL SPRAY HAND SHOWER #672 **1766**
 Includes wall mount holder and voral hose.

FULL SPRAY SHOWER HEAD #672 **397**
 MESSAGE \$7.97
 Refreshing spray.

CHROME MASSAGE ACTION PULSATING SHOWER #665C **1244**
 ANTIQUE BRASS or POLISHED BRASS \$19.97
 Soothes tired, tensed muscles.

69-INCH VORAL HOSE #665C **946**
 Fits all popular massage and regular hand-held showers.



UP WITH VALUE... DOWN WITH PRICES!

5 GALLON SIZE

LATEX FLAT WALL PAINT

\$19

5-GAL.

- Versatile interior surface paint
- White or Antique White
- Quick drying, easy soap and water clean up

Decorative Wall Texture

\$8

5-GAL.

THAT'S ONLY \$1.60 PER GALLON

- Smooth, interior texture for walls and ceilings
- Ready to use
- Conceals cracks and other imperfections

SPRED SATIN LATEX WALL PAINT

\$33

5-GAL.

- Durable, washable latex paint is ideal for wall, ceiling and trim surfaces
- Cleans up with soap and water

INGERSOLL-RAND

5 HP, 20-GALLON GAS POWERED AIR COMPRESSOR

\$463

- Oil-sight glass for easy maintenance
- Built to perform heavy-duty jobs quickly and efficiently
- 15' air hose with air chuck and convenient storage rack

Glidden

ULTRA-HIDE PVA PRIMER

\$29

5-GAL.

- For use on new drywall
- Fast drying, low odor and high hiding
- Easy application: brushed, rolled or sprayed

B-I-N PRIMER SEALER

14.22

1-GAL.

- Blocks out toughest stains and bleeding, resins, knots, smoke damage and water stains.

B-I-N PRIMER SPRAY 2.73

PARKS

ROUGH & READY LIQUID DEGLOSSER

7.33

1-GAL.

- Sandpaper substitute cleans and dulls old surfaces to bond new finishes.

WAGNER

SERIES 500 POWER PAINTER

\$397

- Airless sprayer - no bulky compressor
- Lightweight pump
- Delivers up to 1/3 gal. per minute.
- Large 6 quart hopper and 25' hose!

SAVINGS EVERY DAY

2" x 60 YD. MASKING TAPE

1.33

3M

"PAPER TAPER" MASKING MACHINE KIT

12.63

- 8-pc. kit has all you need to cover and protect surfaces while you paint

DROP CLOTH

9.95

BUTYL BACK DROP CLOTH

15.74

EZ PAINTR.

4.98

- Made of performance formulated synthetics
- Scientifically matched to paints and coatings

EZ PAINTR.

ADJUSTABLE ROLLER FRAME

\$14

- Adapts perfectly to 9", 12", 14" or 18" roller covers
- Standard end caps included

EZ PAINTR.

HOODED TRAY

\$29

- 2 1/2 gallon paint carrying capacity

INGERSOLL-RAND

5 HP, 60-GALLON AIR COMPRESSOR

\$497

- Sturdy construction for light-duty commercial use
- High efficiency fan design
- Enclosed, reusable intake filter

5 HP 80-GALLON \$929

16-FOOT ALUMINUM TYPE III EXTENSION LADDER

\$32

KELLER

- Household duty extension ladder
- Features spring activated solid aluminum extruded rung locks
- 2 1/2" modified "I" beam rail with full single interlock

A "HEARTH" WARMING EXPERIENCE!

HARDWOOD FIREWOOD

237 BUNDLE

36-INCH BUILDERS MODEL FIREPLACE

\$167

- 36" wide firebox opening.
- Ideal for limited space installations
- Complete with glass door.

POLISHED BRASS CLEAR VIEW GLASS SCREEN

\$87

- Features unique trimless door for full view of fire.
- Ideal for limited space installations
- Fully assembled.
- Fits most openings.

DELUXE ENERGY "MIZER" FIREPLACE

\$397

- 36" zero clearance.
- Outside combustion air system.

26-INCH FREE STANDING HEAT CIRCULATING FIREPLACE

\$497

- High volume built in fan.
- Automatic or manual control thermostat.
- Removable ash drawer
- Beautiful mahogany finish

4-FOLD FIRESCREEN

\$19.77

#820

- Dimensions: 32" high by 52" wide.
- Black stamped sheet metal mesh.

FIREPLACE ACCESSORIES!

BOXED FIREPLACE MATCHES

3 FOR \$1

- Multicolored heads.
- 11" long; 90 to a box.

SOLID BRASS BUTANE FIRELIGHTER

5.44

- Suitable for fireplace, gas grill or cooking stoves.

LONG HANDLED BELLOWS

9.44

- Early American design with brass finish nozzle.
- Dimensions: 27-1/2" long by 8" wide.

10-INCH SOLID BRASS CUSPIDOR

9.97

- Highly polished with lacquer finish.
- Assorted embossed insignias.

AMERICAN RANCH MANTLE

\$24

5-FT.

- 2-3/8" thick mantle

8x8 CHIMNEY CAP

15.26

8x13 17.86

13x13 19.53

- Installs in seconds - no tools!

FIRE SETS!

LARGE POLISHED BRASS DUCK HEAD HANDLES

29.97

- Height: 30-1/2", 5 piece zinc die-casted handles, yoke and base.

DELUXE OAK AND POLISHED BRASS

34.97

- Five piece set.
- Oak insert base and handles.

4-BAR 18-INCH STEEL FIREGRATE

4.97

- "Apartment size", sturdy 18" fireplace grate.
- Made of 5/8" steel.

STEEL FIREGRATE

3.97

- 5-Bar design.
- 9/16 inch bars.
- 24 inch length.

BUILDERS SQUARE

Best Retailer
1987

HOLIDAY FIX-UP SALE

AMERICA'S LARGEST HOME IMPROVEMENT WAREHOUSE!

Royal Creations

ENTERTAINMENT CENTER

#23348
\$29

- Extra storage behind double-swing doors.
- Styled in rich "walnut" wood tones.
- Ready to assemble.



#72748

ENTERTAINMENT CENTER

\$79

- Adjustable shelves for components.
- Accented in durable life-like "Nordica Pine" wood tones.
- Rugged solid-core construction.
- Ready to assemble.

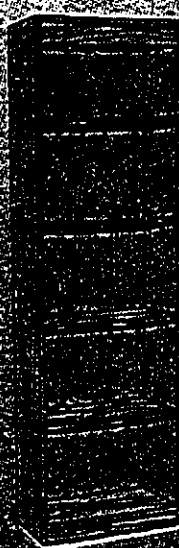

WALL UNITS!

OPEN SHELF

\$39

HICKORY FINISH!

TAMBOUR DOOR MICROWAVE CART

\$29

WITH CUISINE SHELF!

#93241

- Has tambour door and cuisine shelf.
- 28-1/2" H x 23-5/8" W x 17-1/2" D.
- Classic Oak finish.
- Twin wheel casters for mobility.

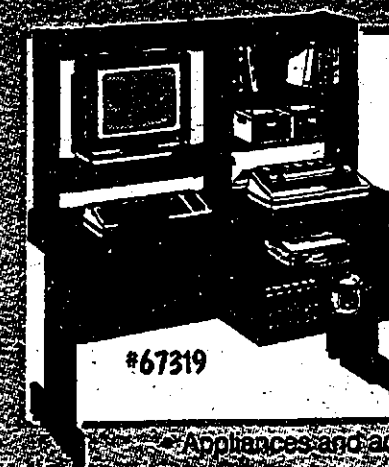

DELUXE COMPUTER CENTER

\$99

- Adjustable shelves throughout.
- Timberland finish.

TIMBERLAND FINISH!



\$49

BUY WHERE THE BUILDERS BUY!

For Your Convenience
Our Store Hours Are:

7:30 am - 9 pm
Monday thru Saturday

9 am - 6 pm
Sunday

VISA

MasterCard

NO MIDDLEMAN MARKUP!

Limited quantities. Sorry, no rainchecks. At least one of each item available in the store at the beginning of the sale.

©1987 BUILDERS SQUARE, INC.

LOWEST PRICES GUARANTEED!

We guarantee the lowest price on every item... everyday! And, if you find a lower price at a competitor (Heaven forbid!) just let us know and we'll change it... plus we'll give you 10% more in SQUARE BUCKS for your next purchase. Identical items only (same manufacturer and model number.) Offer limited to items in stock. No rain checks. Price comparison are at the time of purchase. We reserve the right to limit quantities to dealers and competitors.

IN LIVONIA
30000 PLYMOUTH RD.
AT MIDDLEBELT RD.
ACROSS FROM WONDERLAND MALL
(ONE MILE SOUTH OF I-96)
522-2900

8400 E. 8 MILE (BASELINE)
BETWEEN VAN DYKE (53)
& HOOVER RD.
IN THE OLD BEL AIR DRIVE IN
893-4900

SOUTHGATE
14800 DIX TOLEDO RD
AT EUREKA RD
246-8500

IN NOVI
12 MILE RD. AT NOVI RD.
344-8855

FLINT
G 3603 MILLER RD
AT I 75
733-7582

STERLING HEIGHTS
12000 HALL RD
M59 AT M53
254-4640

MT. CLEMENS
37555 S. GRATIOT
1 BLK. N. OF METRO PKWY.
468-0620