















## Good stuff!

Some "good stuff" came to Village Oaks Elementary School last week in the form of a guitar-playing singer with a chicken puppet. Jerry Jacoby of Detroit entertained students with stories and songs about honesty, respect, how to say you're sorry and how to ask for forgiveness during a program entitled "Good Stuff."

Animated and with prematurely gray hair, the ex-music and vocal teacher said he enjoys his new line of work, which he began on a full time basis last September, because "I can still be with kids my own age."

Jacoby's enthusiasm is catchy. His wide-eyed look of wonder is no put-on and the kids responded overwhelmingly to it. Whether he was being outsmarted by a chicken or telling them how to scare their parents by offering to take the garbage out, he held their attention. An offer of help from their kids was bound to scare most parents, Jacoby knew, but it would also be "good stuff."



Photos by Chris Boyd



Jacoby got plenty of help from students who provided visual aids during a song entitled "D-A-Y."



Jacoby shared top-billing with his chicken puppet. A student reacts to the puppet in the picture above, while the puppet admits to having a crush on second grade teacher Lynn Secord in the picture on the left and proves it by giving her a big kiss.



### Douglas Fir & Fraser Fir Christmas Trees

We have the LARGEST and NICEST selection in the area!  
Over 2,000 to select from: 4 feet to 22 feet. While they last.

Complete line of SCOTCH PINE and SPRUCE Christmas trees, also Fresh Cut Flowers

**WE ALSO HAVE DECORATED WREATHS, HOLLY & MISTLETOE**

12" Ring Size	16" Ring Size
20" Actual Width <b>\$7.99</b>	24" Actual Width <b>\$10.99</b>

24" and 36" also available

ROSES	CHRISTMAS CACTUS
Florist Quality <b>\$9.99 DOZ.</b>	<b>\$2.99 AND UP</b>

CHRISTMAS POINSETTIA
4" ..... <b>\$2.99</b> (25 plants or more 12 1/2")
6 1/2" ..... <b>\$5.99</b> (25 plants or more 15 1/2")
7 1/2" 2 Stem ..... <b>\$12.99</b> (12 plants or more 11 1/2")
8 1/2" 3 Stem ..... <b>\$19.99</b> (12 plants or more 13 1/2")

EXTRA FOR FULL AND BOX

LOTS OF GIFT ITEMS TO SELECT FROM. PLEASE COME IN AND BROWSE AROUND OUR 1 ACRE OF GREENHOUSE WHERE IT'S SUNNY AND WARM

### Holiday Specials

Live Christmas Trees to 7'	\$45
	\$49

Live Table Size 2'	\$4.50 - \$8.75
--------------------	-----------------

Boughs \$1.75 - \$5.75

Wreaths	\$7.50 - \$14.00
---------	------------------

Open Everyday 9-9 for your Shopping Convenience

Call **437-7507**

### HOLLOW OAK FARM NURSERY

11920 Rushton Rd. South Lyon

2 1/2 Miles W. of Pontiac Trail on 8 Mile at the corner of Rushton & 8 Mile

### FARMER JOHN'S GREENHOUSE

26950 HAGGERTY ROAD  
1/2 Mile South of 12 Mile  
553-7141

HOURS: 8am to 9pm Mon.-Sat.  
8am to 6pm Sunday  
CHRISTMAS EVE 'till 6pm

# Lessons learned by all following gasoline spill

By CHRISTOPHER J. KOZLOWSKI  
staff writer

Valuable lessons were learned by both city and gasoline company officials following the Oct. 20 gasoline spill at the Mobil Oil gas station at the Grand River/Haggerty Road intersection.

City and oil company authorities have classified the incident as a "minor spill" — estimates place the amount of gasoline spilled between 25-50 gallons, and have been much worse, especially because the gas station is located next to the Ingersoll Creek which flows into Meadowbrook Lake.

Novi planning commissioners reviewed the incidents which led to the spill, and heard reports from Mobil Oil officials and city representatives during the Dec. 2 commission meeting held at the city's planning commission.

Attorney Joseph Galvin, representing the Mobil Oil Corp., said the spill occurred because a blockage in the vapor valve of one of the underground storage tanks caused the backup of the gasoline valve which was being filled at the time.

Although the exact cause of the valve's back up has yet to be determined, Galvin said the defective valve was replaced and the company does not anticipate future incidents.

Galvin said gasoline is delivered to the Grand River/Haggerty Road site from a gasoline terminal based in Dearborn. He said the corporation has been receiving gas from the terminal more than two years and there has been only one other spill out of an estimated 30,500 trips involving 276 million gallons of gasoline.

"I do not mean at all to minimize the importance of what happened... but this is a very, very infrequent occurrence," Galvin said.

According to Galvin, the steps taken by both the gasoline truck driver and the station's attendant were in accordance with corporate policies.

There are two recommended courses of action to follow when a gas spill occurs, according to Mobil Oil Corp. procedures. When possible, the spilled gas should be wiped up with an absorbent material. In the absence of such material, the gasoline should be washed into the station's drainage system. Procedure also mandates that the material be washed away as soon as possible if there is any possibility of explosion or fire.

Galvin said the station's attendant washed the spilled

gasoline into the drainage system to prevent explosion and because the absorbent material used to clean up spills was not available at the station or on the delivery truck.

Galvin said since the time of the Novi incident the absorbent material is now stored at the station and that all station personnel are prepared to handle emergency procedures.

Controversy concerning the spill also centered on a required oil-gas separator that was not installed at the gas station, despite being part of the site plans which were approved by the city's planning commission.

Although the separator was designed parking lot oil and gas run-off and was not being installed to handle spills, such devices are used to contain a limited amount of spilled gasoline.

According to a report by JCK and Associates, the city's engineering consultants, the oil-gas separator was not installed because it did not appear on subsequent revisions of the station's final site plan, which is used in the construction and inspection process.

As a result of the spill and discovery of the gap in the construction-inspection process, JCK has instituted the following procedures:

- a final site plan check specifically for oil-gas separators;
- notification of the inspection department whenever oil-gas separators are required in a site plan as a "double check" measure;
- inclusion of wetland plans as part of the final site plan; and
- a recommendation to the city's Environmental Committee to explore the possibility of more widespread uses of oil-gas separators in preventing potential disasters.

Planning commissioners discussed the merits of locating gasoline stations near bodies of water and proposed exploring ways to make better use of oil-gas separators as a way to contain gas in the event of a spill.

Commissioner Chairperson Judith Johnson asked commissioners to reconsider whether heavy uses, like gasoline stations, should be allowed in environmentally sensitive areas and urged the Environmental Resources Committee to explore alternatives for safety precautions and procedures. Johnson also encouraged the committee to investigate the amount of spill occurrences which occur.

## City may condemn land

Continued from Page 1

"In any condemnations the city is involved in, property owners are protected. Several appraisals are made, and the owners have a right to contest those appraisals. It could end up in court and before a jury," Kriewall said.

Kriewall explained that the benefit to the public from the proposed condemnation of the Sugden property lies in potential tax revenue from the site. "Redevelopment means a lot to taxpayers in terms of taxes. A continued quality office development in that corridor" would provide that revenue, he told the council and public.

"The current use is a severe detriment to leasing space in that building (LakePointe Office Center). It is a top quality building and when you look out the window... there is difficulty in not feeling that it is a junkyard (the Sugden property adjacent to the office building).

"It is difficult to master plan for development and to continue what we started as long as that use continues," continued the city manager.

"The community hesitates to get involved in condemnations. We like to see property assembled privately," Kriewall explained to the council, "but there has to be a provision for the community to assemble property. We do not encourage this — nor do we like to be involved in them. Yet we want to allow development to the full potential possible while protecting the residents."

Kriewall said the city normally condemns land only for roadway easements and utility right-of-ways. "This is the first time we have considered a condemnation on this order. The overriding benefits are worth it. We are afraid the community will not reach its potential without it."

The city held an informal public hearing on the possibility of condemning the property with the Trammell Crow offer would be accepted. "Could you enter into a contract with me?" Horowitz asked. Assistant City Attorney Dennis Watson said the contract did not have to be limited to Trammell Crow, but that preliminary discussions with the council had indicated that no public money would be spent on the condemnation with all necessary fees coming from the interested developer, who thus far had been the Trammell Crow Company.

Kriewall asked council for a consensus decision to go ahead with discussions concerning the preliminary availability of financing with the Trammell Crow Company for the condemnation. Approval was given by the council.

## Council reservations voiced

Continued from Page 1

Hoyer said the lack of participation by the public in the hearing process further enforces her belief that questions remain on the interpretation of the eminent domain statute. "No public protest has come out on the condition of the site, just Trammell Crow protest," she said. "I have some real concerns... I don't want to misuse the statute."

### CITY OF NOVI NOTICE OF ENACTMENT AMENDMENT TO ZONING ORDINANCE

THE CITY OF NOVI ORDAINS:

PART I. That Ordinance No. 84-18, known as the Zoning Ordinance of the City of Novi, is hereby amended by the amending of the Zoning Map as indicated on ZONING MAP NO. 18,457, attached hereto and made a part of this Ordinance.

PART II. CONFLICTING PROVISIONS REPEALED. Any ordinance or parts of any Ordinance in conflict with any of the provisions of this Ordinance are hereby repealed.

PART III. WHEN EFFECTIVE. The provisions of this Ordinance are hereby declared to be necessary for the preservation of the public peace, health and safety and it is hereby ordered to take effect ten (10) days after final enactment and publication. The effective date of this Ordinance is December 17, 1987.

Made and passed by the City Council of the City of Novi, Michigan, this 7th day of December, 1987. Copies of the Ordinance Amendment may be purchased or inspected at the Office of the City Clerk, Novi, Michigan, weekdays between 8:00 AM and 5:00 PM.

MATTHEW C. QUINN, MAYOR  
GERALDINE STIPP, CLERK

To rezone a part of the NE 1/4 of Section 1, T.1N., R.8E., City of Novi, Oakland County, Michigan, being parcel 22-1-200-005, more particularly described as follows:  
The west 150 feet of the north 290 feet of the east 16 acres of the north 36 acres of the northeast 1/4 of Section 1.  
EXCEPTING THEREFROM: Any parts of the above described lands taken, deeded or used as a street, road or highway:  
FROM: R-4 RESIDENTIAL AGRICULTURAL DISTRICT TO: OS-1 OFFICE SERVICE DISTRICT

ORDINANCE NO. 18,457  
ZONING MAP AMENDMENT NO. 457  
CITY OF NOVI, MICHIGAN  
CERTIFICATION OF ADOPTION

I, Geraldine Stipp, Clerk of the City of Novi, do hereby certify that the above Ordinance was approved and adopted by the Council of the City of Novi, at a Regular Meeting thereof, duly called and held on this 7th day of December, 1987, and was ordered to be given publication in the manner prescribed by law.

GERALDINE STIPP, CLERK  
(12/10/87 NR, NN)

### Annual Northville-Novi Colts Christmas Tree Sale

Located in the Ford Plant Employee's Lot (Corner of Main & Griswold)  
"Home of the Ducks"

## PREMIUM QUALITY TREES

HOURS:  
3 p.m.-9 p.m. Daily  
9 a.m.-9 p.m. Sat.  
9 a.m.-6 p.m. Sun.

"Merry Christmas from the Colts"

THANK-YOU FORD MGMT. & EMPLOYEES

Proceeds of sale for the benefit of Colts Junior League Football Program

### CITY OF NOVI NOTICE OF ENACTMENT AMENDMENT TO ZONING ORDINANCE

THE CITY OF NOVI ORDAINS:

PART I. That Ordinance No. 84-18, known as the Zoning Ordinance of the City of Novi, is hereby amended by the amending of the Zoning Map as indicated on ZONING MAP NO. 18,458, attached hereto and made a part of this Ordinance.

PART II. CONFLICTING PROVISIONS REPEALED. Any ordinance or parts of any Ordinance in conflict with any of the provisions of this Ordinance are hereby repealed.

PART III. WHEN EFFECTIVE. The provisions of this Ordinance are hereby declared to be necessary for the preservation of the public peace, health and safety and it is hereby ordered to take effect ten (10) days after final enactment and publication. The effective date of this Ordinance is December 17, 1987.

Made and passed by the City Council of the City of Novi, Michigan, this 7th day of December, 1987. Copies of the Ordinance Amendment may be purchased or inspected at the Office of the City Clerk, Novi, Michigan, weekdays between 8:00 AM and 5:00 PM.

MATTHEW C. QUINN, MAYOR  
GERALDINE STIPP, CLERK

To rezone a part of the NE 1/4 of Section 28, T.1N., R.8E., City of Novi, Oakland County, Michigan, being parcel 22-1-200-005, more particularly described as follows:  
The west 150 feet of the north 290 feet of the east 16 acres of the north 36 acres of the northeast 1/4 of Section 1.  
EXCEPTING THEREFROM: Any parts of the above described lands taken, deeded or used as a street, road or highway:  
FROM: R-4 RESIDENTIAL AGRICULTURAL DISTRICT TO: OS-1 OFFICE SERVICE DISTRICT

ORDINANCE NO. 18,458  
ZONING MAP AMENDMENT NO. 458  
CITY OF NOVI, MICHIGAN  
CERTIFICATION OF ADOPTION

I, Geraldine Stipp, Clerk of the City of Novi, do hereby certify that the above Ordinance was approved and adopted by the Council of the City of Novi, at a Regular Meeting thereof, duly called and held on this 7th day of December, 1987, and was ordered to be given publication in the manner prescribed by law.

GERALDINE STIPP, CLERK  
(12/10/87 NR, NN)

## Score One For Our Team.

FORN SERVICE-USA







# Opinions

theNOV  
NEWS

**18A**  
THURSDAY  
December 10,  
1987

## Headed for Hoosier-land



**Christopher J. Kozlowski**

My eight-month stay with Sliger-Livingston Publications will be over just before Christmas, as I am to begin my first experience on a daily newspaper in Fort Wayne, Ind. I am very much looking forward to my new job, but I know I will surely miss the friends I was fortunate to meet during my stay.

The Novi News and Northville Record allowed me the opportunity to gain my first professional journalism experience. And although the road may have been a bit rocky at times, especially at every commission meeting past midnight, my experiences here were very beneficial to me in many ways.

I am very grateful for the opportunity to gain my first journalistic experience at newspapers which are as devoted to the communities they serve as the Novi News and the Northville Record. Northville (the township and the city) deserves a newspaper which respects the community's long history and has more than a vested interest in its future.

Novi, a city which has yet to realize its ultimate potential, is a community which is an exciting one to be

## Forum

By Chris Boyd

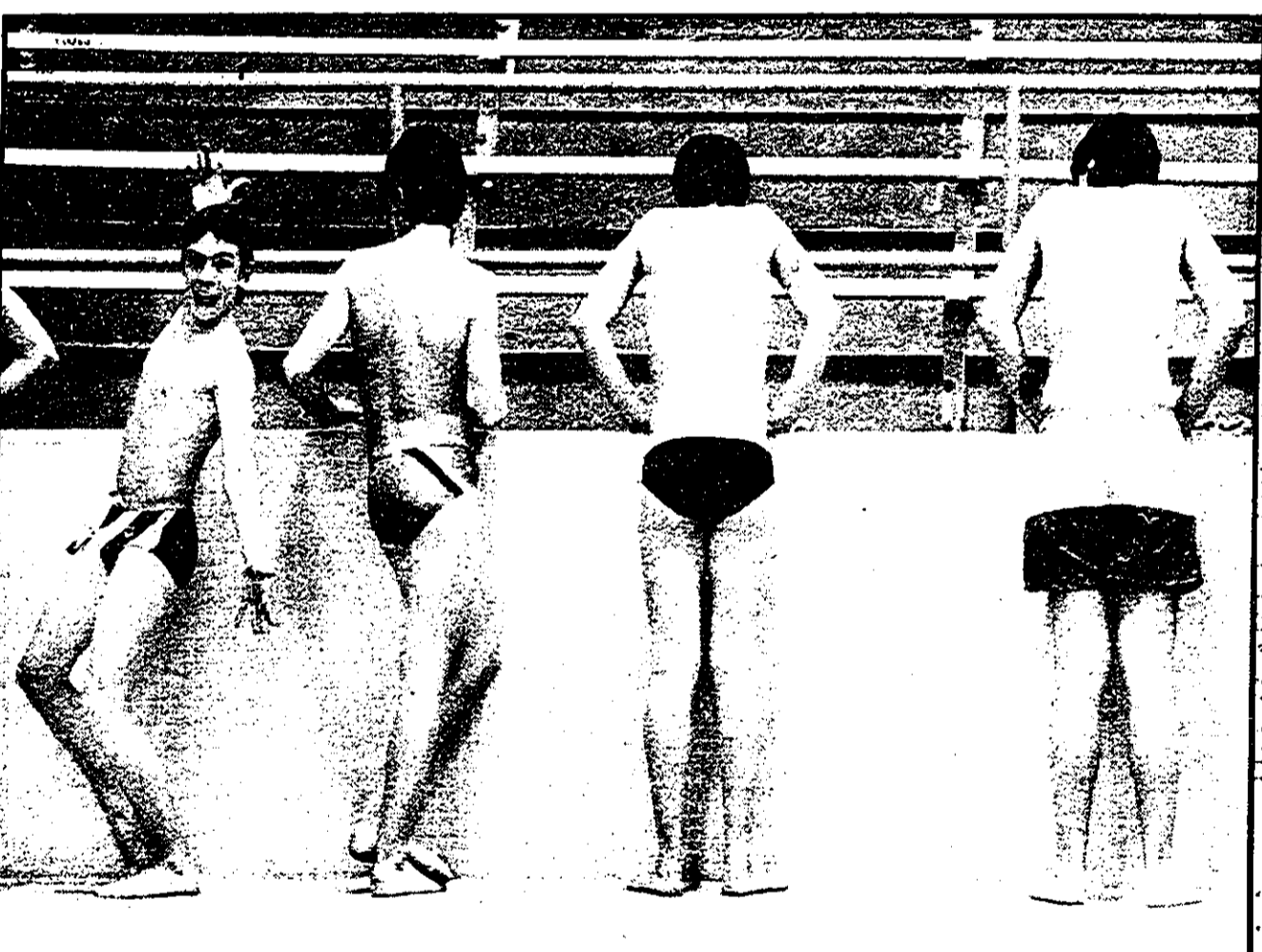

**Swimsuit competition**

## The Grinch hits close to home



**Phil Jerome**

The problem is that some of the decorations are edible. Like the vase filled with candy canes, the glass cookie jar filled with spiced red-and-green gum drops and the little candy dish filled with chocolates wrapped in brightly-colored paper.

Actually, the real problem is that the edible decorations have a tendency to disappear. . . . and I'm the one who gets blamed for it.

"I have one request," she said sternly when I got home for dinner the other night. "I've learned to accept

**But more than that, I will miss the people who have shed a brighter light on what life in suburban America is like, and what the role of the community newspaper is all about.**

around and promises to be even more exciting in the not-too-distant future.

Both communities deserve to be well-informed, and neither newspaper would ever be guilty of keeping its community in the dark.

I will surely miss the rich variety of news content that each community boasts each week, especially at the stage of development that Novi is in now (no pun intended). But more than that, I will miss the people who've shed a brighter light on what life in suburban America is like, and what the role of the community newspaper is all about.

My co-workers have given me an even better education, it seems, than four years of college could have ever provided. I shall always appreciate their friendship, and try to live up to their professional standards. Thank you for letting me stand in your shadows. And if you ever feel like visiting a "Hoosier," you know where I live.

## 'Church would be asset to city'

**Letters**

To the Editor: I was amazed to hear that the city planning commission rejected the proposed Pius X Chapel complex at Ten Mile, west of Beck Road.

We are a strange city indeed. We don't seem to want churches, schools or hospitals. Well, maybe it's just in somebody else's backyard. Yet we seem perfectly content with walk-to-work strip malls.

The good people from the Pius X Church should have told the planning commission they were planning a strip mall with 15 stores, none of which were leased or likely to be leased in the foreseeable future.

For good and for bad, Novi is a growing city. One of the most valuable assets of any city is its infrastructure. Among the elements of infrastructure are churches, schools and hospitals.

To deny the whole city the valuable addition of the Pius X project in order to nurse the rapidly fading illusion that everyone in Novi is a child with a rattle.

William J. Welter

## Music lovers

To the Editor: We're wondering if the music lovers in Novi realize that we have the opportunity to enjoy good music "right here in our own backyard."

We're referring, of course to the many fine performances presented throughout the year by the Novi High School bands, choir and jazz groups.

They are not, they are performed by talented and enthusiastic young musicians from our community for the enjoyment of the whole community.

On Wednesday, December 16, at 7:30 p.m. the Novi High School Symphony and Concert Bands under the direction of Craig Strain and Paula Meyer will perform the annual Winter Concert at Fuerst Auditorium.

Refreshments will be served in the lobby following the concert.

Morris and Karen Christlieb

## Providence head talks of plans

through the next phase, but beyond that, we could not really accommodate the needs of the Novi community. We would again be out of space and landlocked.

"Part of the reason we are interested in that site is it does have the kind of traffic patterns that are supportive of this kind of development."

Have you met with area residents to discuss conflicting opinions, and will there be any future meetings held in an attempt to resolve differences?

CONNOLLY: "We do not have a 'Plan B' at this point."

CONNOLLY: "We did meet with the leadership of the CCN, and we met with them at the Novi center about two months ago. We gave them a brief overview of our proposal. The purpose of the meeting was to really listen to their concerns. We had hoped to take their concerns into consideration as we developed this proposal."

"The primary concerns were patterns of the traffic, the impact the facility would have on the school, and deviating from the existing Master Plan. We indicated to them that we would have a traffic consultant do a site analysis. We also suggested that we would be happy to construct lighted sidewalks along our property to help facilitate traffic patterns."

"We also told them that part of the reason that site may not have been chosen for a health care facility is I do not believe the planners developing the Master Plan were thinking about health care."

"We are going to contact CCN leader Rick Spivey and hope to meet with him prior to the Dec. 16 planning commission meeting, and hope to share with him the results of our traffic study, and go over the facts on the proposed facility."

"It seems we get rumors back periodically about what we plan to do on the site, which are not consistent with what the facts are."

"One important part about that meeting, and that meeting with the Planning Concepts Committee, is the CCN is supportive of Providence Hospital. They are very supportive of the hospital's programs, and very supportive of Providence Hospital."

"It has really been a wonderful association. And all the residents I have talked to, most of them begin their comments, 'Don't misunderstand, we are delighted that you want to continue to provide services to Novi. We welcome you to Novi.' The questions relate primarily to the site."

"How feasible would it be to expand Providence's current facility in order to provide for increased future need in Novi?"

CONNOLLY: "Without the addition of large additional acreage, it is not feasible. We own about 10 acres. And we could probably expand

to consider any creative land parceling developments that the city may want to pursue. But we have done an exhaustive analysis of available properties, and to the best of my knowledge there are no lots of this size that meet our criteria in the city of Novi."

"One other comment that is important for the citizens of Novi to consider is that Providence Hospital is sponsored by the Daughters of Charity. The Daughters of Charity is the largest non-profit health care provider in the United States."

"The health care industry is going through something between an evaluation and a revolution. There are major changes. You can see a lot of the small community hospitals, and even some of the larger hospitals, are struggling and not doing well. But I think Novi has the opportunity to be served by a premier, if not the premier non-profit health care provider in the country."

"The Daughters of Charity have provided health care services to the citizens of Michigan longer than any other health care provider in the state. And they are going to be here for a long time. Our philosophy and the values that the Daughters have is a community-oriented philosophy."

"Their philosophy and our reason for wanting to provide services are different. But we do want to provide health care provider might do. So we are truly interested in serving the community."

"I don't know how much that issue is being considered when people think about the provision of health care services. There are no substitutes for the Daughters of Charity and the kind of health care they provide."

"It is a unique opportunity for the citizens of Novi. That is not to say that we are not equally thankful for the opportunity to provide health care services. It really is a wonderful community."

Is there any other information you would like to convey to Novi residents to better help them understand the project you are proposing?

CONNOLLY: "It is important to be familiar with the facts and understand what the facts are. So much of our health care decisions we have made, and based on misinformation."

"We have heard from, up to this point, the vocal minority. Which is understandable because it is the group that lives closest to the site and perceives that the impact will be greatest on their particular community."

"But the city of Novi is made up of some 26,000-30,000 people, and our analysis indicates the majority of the citizens of Novi support the development of this program at this site. And what we have heard from thus far has been from the vocal minority."

"We would like for those citizens who are supportive of this development to also come forward and speak out in support of the program."

"We are not interested in developing a program where there is no support. If there is no support, we are not interested. But we have done surveys, and the majority of the Novi community supports the development of this program. And we hear otherwise, we are going to continue to pursue the program."

## CELEBRATE A SUITE NEW YEARS EVE WITH RADISSON SUITE HOTEL AND PERIWKLES

**SUITE NEW YEAR'S EVE PACKAGE I**  
\$189.00 (plus tax)

- DELUXE OVERNIGHT SUITE ACCOMMODATIONS FOR TWO WITH EARLY CHECK-IN AND CHAMPAGNE UPON ARRIVAL
- DINNER FOR TWO IN PERIWINKLES
- DANCING TO THE EARL VAN RIPER TRIO
- NEW YEAR'S DAY BUFFET BREAKFAST
- LATE CHECK-OUT

**SUITE NEW YEAR'S EVE PACKAGE II**  
\$99.00 (plus tax)

- DELUXE OVERNIGHT SUITE ACCOMMODATIONS FOR TWO WITH EARLY CHECK-IN AND CHAMPAGNE UPON ARRIVAL
- NEW YEAR'S DAY BUFFET BREAKFAST
- LATE CHECK-OUT

FOR RESERVATIONS, CALL 477-7800

ADDITIONAL ROOM NIGHTS AVAILABLE WITH ALL PACKAGES \$45.00 PER ROOM/PER NIGHT. CONTACT HOTEL RESERVATIONIST FOR DETAILS AND ADDITIONAL PACKAGES.

Radisson Suite Hotel Farmington Hills  
Periwinkles

## Commercial Carpet Corp. has

**DU PONT CERTIFIED STAINMASTER CARPET**

### in the Colors and Styles You Want

Visit Our Residential Showroom  
Over 200 Colors And Styles On Display

**Commercial Carpet Corporation**  
477-7722

40400 Grand River (West of Haggerty Road)  
Suite A Novi, MI 48050

Open Mon-Sat 10am-5pm Evenings By Appointment  
Major Credit Cards Honored

## Holiday Savings

FOR EVERY ROOM IN YOUR HOME!

**35-50% off**

Cascade Custom Draperies  
Choose from our entire collection including silhouettes, sheers, prints, open weaves and multi-purpose fabrics at 35-50% off. 30% off coordinating Top Treatments and Bedspreads. Sale includes fabric, labor, lining and installation.

**40-50% off**

- 45% off Sunrise and Sunset Custom Aluminum Blinds.
- 50% off Sierra Wood Blinds.
- 40-50% off Viewscapes Vertical Blinds - in vinyls and fabrics.
- 45% off Aurora Pleated Shades.

Sale prices include installation.

**32-43% off**

- Wearated Nylon - Moodmaker Scotland? treated. Reg. \$21. Sale \$17.99 sq. yd. installed.
- Dacron? Polyester - Soffly Suede. Reg. \$36. Sale \$20.99 sq. yd. installed.
- DuPont Stainmaster? - Evening Magic. Reg. \$35. Sale \$19.99 sq. yd. installed.

Sale includes normal installation and padding.

Sale ends Dec. 26th.

Percentages off represent savings from regular prices.

**JCPenney Custom Decorating**

Norland 568-8570, Southland 374-0510, Eastland 523-0200, Westland 522-3011, Farmdale 242-3210, Oakdale 543-7060, Lakeside 242-0600, Westdale 348-7822, Briarwood 769-1077, Northwood Center 288-2990.

# TAKE FIVE VIDEO

LOCATION

TEN MILE AT NOVI ROAD

# NOW OPEN

**MONDAY-SATURDAY**  
10 a.m. - 10 p.m.

**SUNDAY**  
Noon - 6:00 p.m.

**349-0960**

## GRAND OPENING GIVEAWAYS

- MAGNAVOX CAMCORDER AND CASE
- MAGNAVOX 20" COLOR TELEVISION
- MAGNAVOX VCR

**Come In To Register For Our  
Grand Opening Drawing!**

Drawing To Be Held Wed. Dec. 23 at 6:00 p.m.

Section  
**B**

# GREEN SHEET

Sliger/Livingston East

Wednesday/Thursday — December 9/10, 1987

Want Ads  
INSIDE

## Pictures Plus Gallery offers frames and a lot more

By JEAN DAY



Bill and Dee Richardson offer custom framing service at Pictures Plus Gallery in Northville

Pictures Plus Gallery at 154 Mary Alexander Court in downtown Northville has been open only two weeks, but its owners, Bill and Dee Richardson, are no strangers to the community.

For seven years they have operated Northville Camera Shop located a block away at 105 E. Main. Part of the camera shop's business was frames and custom frames — it still is as the shop will continue to carry frames and do framing, especially of photographs.

Pictures Plus Gallery, however, in the spacious location at the east end of Mary Alexander Court, will have much more. In addition to in-stock frames, the gallery — which is managed by Dee Richardson — offers a large, varied selection of made-to-order frame styles in a spectrum of colors as well as gold.

In addition to the made-to-order frames, the gallery offers many framed pictures, from numbered prints to original watercolors and antique maps and lithographs. Many are framed and hanging on the carpeted walls and on display easels.

Dee Richardson points out that the neutral carpeting and wallpapers were used deliberately so that customers can bring in samples of their own wallpapers and fabrics.

Many of the pictures on display have double or triple matting. Mats are available in a full range of colors, and the shop will frame with wallpaper, silk, suede or leather matting if the customer wishes.

The gallery also will do decorator mirrors to order.

"We're featuring irises," Dee Richardson says, pointing to an original watercolor done by a Michigan artist. She notes that irises are "in" since the Van Gogh painting of watercolors recently sold for \$53.9 million. Another iris picture is in a contemporary mood.

Richardson stresses that the gallery is set up to offer ideas for home or office. Special effort has been made to have art for offices.

An impressive antique map, bought by the Richardsons at an antique show, has been framed handsomely in a dark wood frame with brass corners. It hangs near a large

Continued on 3

**Gifts for the Special Men on your list**

**HOMELITE JACOBSEN**

**Super XL**  
with 20" Bar • 3.55 cu. in. engine  
Retail \$405.00 • CD ignition  
Sale \$279.00 • Auto oiling  
• Manual oil override  
• All metal construction  
• Heavy duty rating  
• 20" 3/8 chain

**NEW HUDSON POWER**

**Chain Saws**  
VISUPER 2-14"

Vibration Isolation  
Retail \$229.99  
Dealer cost \$179.99

**Sale \$149.00**

• 14 inch chrome chain  
• 14 inch sprocket 110 bar  
• CD Ignition • 1.9 cu. in. engine  
• All metal construction

**53535 Grand River at Haas Rd.**  
2 Miles East of Pontiac Trail  
Hours: Mon., Fri. • Thurs. 9-8  
Sat. 9-3  
Layaway available  
(313) 437-1444

**Fletcher & Rickard**  
LANDSCAPE SUPPLIES INC.  
437-8009  
54001 Grand River  
New Hudson, Michigan 48165  
Hours: Mon.-Fri. 12-6  
Sat. 9-5; Sun. 11-3  
Locating 2 miles east of Westport Road

YOUR **garden** AND LANDSCAPING CENTER

Propane Filling  
While You Wait

**SUPER-K KEROSENE**

SEASONED HARDWOOD  
FIREWOOD  
Full line of landscape  
completing and lighting  
supplies  
7 Day Pickup & Delivery

Replacement Kerosene Heater Wicks & Accessories

**SEVERSON'S MILL & FARM SUPPLY**  
56675 Shepko Road • New Hudson, Michigan 48165  
Mon-Sat (313) 437-1723  
9-6

Langs Dealer • Complete Pet Supplies  
Complete Line of Carnation Feeds  
• Custom Feed Made Daily  
In the Historical  
New Hudson Elevator

Live Stock  
Hauling

New Item: Paper Shaving's Bedding. Use with Horse's, Cattle or Chicken's. VERY Absorbent, Mix With Straw and Shaving's or Use Straight!

**Dan's Auto Repair**  
43151 Grand River  
348-1230

Lifetime  
Guarantee

**Brake Pads**  
\$29.97 per wheel  
Metallic Extra Most Cars

**Greg Stryker Band\***  
formerly The Front  
is appearing at Rascal's Lounge  
Mon., Dec. 7 - Sat., Dec. 12  
One Week Only!

**Drink Specials Mon - Thurs.**  
Receive a drink special 35¢  
Mon-Thurs only with this ad

26800 Pontiac Trail (Between 11 & 12 Mile) South Lyon

**South Lyon Collision Inc.**  
Equipped to rebuild your car  
back to manufacture  
specifications

437-6100 or 437-3222

- Frame & Unibody Straighten
- 2 & 4 Wheel Alignment
- Repairs completed with OEM parts & OEM paint

150 E. McHattie  
South Lyon

**Family Foot Centers**  
LASER AND ANGIOLOGY  
FOOT SURGERY

FREE  
FOOT EXAM

**887-5800**

Highland Millford Foot Specialists P.C.  
Dr. Lefkowitz, Dr. Steiner, Dr. Richard

Highland  
Across From Stach's  
1183 S. Millford Rd.

MORN., AFTERNOON, EVE. & SAT.  
APPOINTMENTS AVAILABLE

FOOT PROBLEMS?  
• Ingrown Toenails  
• Diabetic Feet • Heel Pain  
• Ankle Injury  
• Surgery-Office, Hospital

• Bunions • Hammer Toes  
• Corns • Calluses  
• Fractures • Sprains  
• Arthritic Feet

• Warts-Hands/Feet  
• Child's Feet • Skin Growths  
• Sports Medicine • Orthotics

MOST INSURANCE ACCEPTED  
INCLUDING: MEDICAID, ELLIE CROSS,  
MEDICARE, AETNA, TRAVELERS,  
HANCOCK, AMERICAN COMMUNITY,  
AND ALL OTHER PRIVATE CARRIERS

\* EXCLUDES X-RAY LAB.  
TREATMENT

**Focus on America's Future**

Help Prevent Birth Defects  
Support the  
**March of Dimes**  
BIRTH DEFECTS FOUNDATION

**Delicious Holiday Treats From ...**

**Guernsey FARMS DAIRY**  
MILK-ICE CREAM  
Premium Quality  
"World Famous Butter Pecan Ice Cream"

**EGG NOG**  
Rich, Creamy, Fresh and Delicious

**WHIPPING CREAM**  
Fresh, Pasteurized for the best, Finest Whipped Cream Ever

**SPECIAL ICE CREAM TREATS.....**  
Santa Bears, Santa Claus  
Christmas Trees, Snowmen, Gingerbread Men

**WE CARRY Morley CANDY**  
Visit Our Gift Shop For Your Holiday Shopping

**BROASTED CHICKEN IS OUR SPECIALTY!**  
Breakfast • Lunch • Dinner  
NORTHVILLE • 349-1466  
21300 Novi Rd.

Monday-Friday 7 a.m.-10 p.m.  
Saturday & Sunday 8 a.m.-10 p.m.  
LIVONIA • 427-5590  
10840 Farmington Rd. (at Plymouth Rd.)  
Restaurant at Northville Location Only

**ERA RYMAL SYMES**

**There Really Is A Difference  
In Real Estate Companies**

**SALESPERSONS  
OF THE  
MONTH**

**OPEN HOUSE**

PLYMOUTH — Park Area Home! Expensive 1 1/2 story Traditional. Meticulous upkeep, aluminum siding, Electronic door opener, fireplace warmth, beamed ceilings, French Doors, Wood Paneling, Formal Dining Room, Eat-in Kitchen, 4 Bedrooms, 2 baths, Wood Windows. Also — Pantry, foyer, deck, 2-car garage and Partially Finished Basement — Near recreation, \$138,900. OPEN HOUSE: Sunday, December 13, 2-6 p.m. 1436 Northville Rd. ERA RYMAL SYMES  
Call 478-4550

**PAM CUDDY  
NOVI**

NOVI — Comfortable & Hospitable Ranch! Brick exterior, Freshly decorated Great family area, fenced in yard, carpeting, 3 bedrooms, 1 1/2 baths, 2-car attached garage, decorator upgrades. Near Schools & Shops. \$81,500. Call 478-9130 ERA RYMAL SYMES

**JUDY DORE'  
NORTHVILLE**

NOVI — 2 Story Brick Contemporary offering Cheerful heart. Great family area, 2-car garage, electronic door opener, central air, gas heat, hardwood floors, foyer, family room, extra large closets, eat-in kitchen, 3 bedrooms, 2 baths. \$113,250. Call 478-9130 ERA RYMAL SYMES

**Novi Office 478-9130 West Bloomfield Office 851-9770 Northville Office 349-4550**



### To Place Your Action Ad One Local Call Does It All...

Monday Green Sheet  
Wednesday Green Sheet  
Wednesday Green Sheet Plus  
Pinciney, Hartland, & Howletville Shoppers

- 313 227-4436
- 517 548-2570
- 313 348-3022
- 313 437-4133
- 313 685-8705

### Deadlines

Monday Green Sheet ..... Fri. 3:30 p.m.  
Wednesday Green Sheet Plus ..... Fri. 3:30 p.m.  
Wednesday Green Sheet ..... Mon. 3:30 p.m.  
Buyer's Directory ..... Fri. 3:30 p.m.

### RATES

#### GREEN SHEET PLUS 3 ACTION ADS

10 words for \$5.99

### Classified Display

Contract Rates Available  
Buyer's Directory  
Real Estate Listings  
Lost and Found  
Automotive  
Apartment Rentals  
Pet Services

### absolutely FREE

#### 001 Absolutely Free

CHRISTMAS kittens, 6 weeks, \$12.50-15.00  
CLEAN Fil Dirt, You Haul It  
CLOTHING: Howell Church of Christ  
COLD spa refrigerator, no responsibility  
CUTE shorthaired grey kitten, also 2 adult cats  
DOLBY OVEN 40" Works Female, \$138.88-511  
FEMALE dog, Spayed, show quality  
FREE Electric Range, Free  
FREE Christmas Cards, 250, \$1.50  
FREE Christmas Cards, 250, \$1.50  
FREE Christmas Cards, 250, \$1.50

#### 001 Absolutely Free

2 BASKET puppies, females, 10 weeks, \$13.99-16.99  
2 cats, 1 male all shots, 1 female, \$13.99-16.99  
2 FREE haircuts, call after 6 p.m. (313) 882-5439  
3 PEECE Living Set, Good quality, \$129.99  
5 YEAR old German Shepherd, \$500.00  
7 WEEK old German Shepherd, \$200.00  
7 MONTH old Shepherd and Lab, \$100.00  
8 CHICKS hatched this year, \$17.50-25.00  
99 BLACK Redliner, sink and cabinet, \$128.99-177.99  
ABANDONED Beagle puppy, approximately 2 months, housebroken, loves kids, \$17.50-25.00

#### 001 Absolutely Free

ADORABLE Black/white Kitten, neutered, inside only, \$12.00-22.00  
AKC Blue Collie, Female, Shots, spayed, debarbed, 3 years, \$13.00-22.00  
AKC registered pure white German Shepherd, female, 2 years, \$13.00-22.00  
ALPINE goat, adult female, good with horses, \$12.00-22.00  
ANIMAL AID, Free adoptable pets, Brighton Big Acre, Saturdays 10:00 p.m.  
RECONDITIONED PETS, adoptable, low cost, \$13.00-22.00  
AQUARIUM, good for guinea pigs or hamsters, \$12.00-22.00  
ADDSIE Rotweiler mixed puppies, eight weeks, \$13.00-22.00  
BEAGLE/COCKER Spaniel, loving small 1 year old spayed female, \$13.00-22.00  
SELL in Howell, electronics, course material, colored TV chassis, \$12.00-22.00  
BLACK German Shepherd, \$12.00-22.00  
BLACK Lab pups, 10 weeks, \$12.00-22.00  
BLACK Lady-boy recliner, needs upholstering, \$12.00-22.00  
CHRISTMAS kittens, loving, hand raised orphans, litter, \$12.00-22.00  
CHRISTMAS puppies, available December 12, Mother colic, \$12.00-22.00

#### 001 Absolutely Free

2 BASKET puppies, females, 10 weeks, \$13.99-16.99  
2 cats, 1 male all shots, 1 female, \$13.99-16.99  
2 FREE haircuts, call after 6 p.m. (313) 882-5439  
3 PEECE Living Set, Good quality, \$129.99  
5 YEAR old German Shepherd, \$500.00  
7 WEEK old German Shepherd, \$200.00  
7 MONTH old Shepherd and Lab, \$100.00  
8 CHICKS hatched this year, \$17.50-25.00  
99 BLACK Redliner, sink and cabinet, \$128.99-177.99  
ABANDONED Beagle puppy, approximately 2 months, housebroken, loves kids, \$17.50-25.00

# Sliger/Livingston Publications

## GREEN SHEET EAST CLASSIFIED ACTION ADS

### 010 Special Notices

DJ  
\*Music Brothers  
DJ  
\*Music Brothers  
DJ  
\*Music Brothers

### 015 Lost

LARGE Husky  
LARGE Husky  
LARGE Husky  
LARGE Husky

### 021 Houses

BRIGHTON SERENE  
BRIGHTON SERENE  
BRIGHTON SERENE  
BRIGHTON SERENE

### 021 Houses

BRIGHTON area  
BRIGHTON area  
BRIGHTON area  
BRIGHTON area

### 021 Houses

Perfect starter home  
Perfect starter home  
Perfect starter home  
Perfect starter home

### 010 Special Notices

FREE pregnancy test  
FREE pregnancy test  
FREE pregnancy test  
FREE pregnancy test

### 015 Lost

ABANDONED cat  
ABANDONED cat  
ABANDONED cat  
ABANDONED cat

### 021 Houses

PREVIEW PROPERTIES  
PREVIEW PROPERTIES  
PREVIEW PROPERTIES  
PREVIEW PROPERTIES

### 021 Houses

PREVIEW PROPERTIES  
PREVIEW PROPERTIES  
PREVIEW PROPERTIES  
PREVIEW PROPERTIES

### 021 Houses

PREVIEW PROPERTIES  
PREVIEW PROPERTIES  
PREVIEW PROPERTIES  
PREVIEW PROPERTIES

### 001 Absolutely Free

CHRISTMAS kittens, 6 weeks, \$12.50-15.00  
CLEAN Fil Dirt, You Haul It  
CLOTHING: Howell Church of Christ  
COLD spa refrigerator, no responsibility  
CUTE shorthaired grey kitten, also 2 adult cats  
DOLBY OVEN 40" Works Female, \$138.88-511  
FEMALE dog, Spayed, show quality  
FREE Electric Range, Free  
FREE Christmas Cards, 250, \$1.50  
FREE Christmas Cards, 250, \$1.50  
FREE Christmas Cards, 250, \$1.50

### 001 Absolutely Free

CHRISTMAS kittens, 6 weeks, \$12.50-15.00  
CLEAN Fil Dirt, You Haul It  
CLOTHING: Howell Church of Christ  
COLD spa refrigerator, no responsibility  
CUTE shorthaired grey kitten, also 2 adult cats  
DOLBY OVEN 40" Works Female, \$138.88-511  
FEMALE dog, Spayed, show quality  
FREE Electric Range, Free  
FREE Christmas Cards, 250, \$1.50  
FREE Christmas Cards, 250, \$1.50  
FREE Christmas Cards, 250, \$1.50

### 010 Special Notices

AIRLINE ticket, Detroit to London  
AIRLINE ticket, Detroit to London  
AIRLINE ticket, Detroit to London  
AIRLINE ticket, Detroit to London

### 015 Lost

ABANDONED cat  
ABANDONED cat  
ABANDONED cat  
ABANDONED cat

### 021 Houses

PREVIEW PROPERTIES  
PREVIEW PROPERTIES  
PREVIEW PROPERTIES  
PREVIEW PROPERTIES

### 021 Houses

PREVIEW PROPERTIES  
PREVIEW PROPERTIES  
PREVIEW PROPERTIES  
PREVIEW PROPERTIES

### 021 Houses

PREVIEW PROPERTIES  
PREVIEW PROPERTIES  
PREVIEW PROPERTIES  
PREVIEW PROPERTIES

### 001 Absolutely Free

CHRISTMAS kittens, 6 weeks, \$12.50-15.00  
CLEAN Fil Dirt, You Haul It  
CLOTHING: Howell Church of Christ  
COLD spa refrigerator, no responsibility  
CUTE shorthaired grey kitten, also 2 adult cats  
DOLBY OVEN 40" Works Female, \$138.88-511  
FEMALE dog, Spayed, show quality  
FREE Electric Range, Free  
FREE Christmas Cards, 250, \$1.50  
FREE Christmas Cards, 250, \$1.50  
FREE Christmas Cards, 250, \$1.50

### 001 Absolutely Free

CHRISTMAS kittens, 6 weeks, \$12.50-15.00  
CLEAN Fil Dirt, You Haul It  
CLOTHING: Howell Church of Christ  
COLD spa refrigerator, no responsibility  
CUTE shorthaired grey kitten, also 2 adult cats  
DOLBY OVEN 40" Works Female, \$138.88-511  
FEMALE dog, Spayed, show quality  
FREE Electric Range, Free  
FREE Christmas Cards, 250, \$1.50  
FREE Christmas Cards, 250, \$1.50  
FREE Christmas Cards, 250, \$1.50

### 010 Special Notices

AIRLINE ticket, Detroit to London  
AIRLINE ticket, Detroit to London  
AIRLINE ticket, Detroit to London  
AIRLINE ticket, Detroit to London

### 015 Lost

ABANDONED cat  
ABANDONED cat  
ABANDONED cat  
ABANDONED cat

### 021 Houses

PREVIEW PROPERTIES  
PREVIEW PROPERTIES  
PREVIEW PROPERTIES  
PREVIEW PROPERTIES

### 021 Houses

PREVIEW PROPERTIES  
PREVIEW PROPERTIES  
PREVIEW PROPERTIES  
PREVIEW PROPERTIES

### 021 Houses

PREVIEW PROPERTIES  
PREVIEW PROPERTIES  
PREVIEW PROPERTIES  
PREVIEW PROPERTIES

### 001 Absolutely Free

CHRISTMAS kittens, 6 weeks, \$12.50-15.00  
CLEAN Fil Dirt, You Haul It  
CLOTHING: Howell Church of Christ  
COLD spa refrigerator, no responsibility  
CUTE shorthaired grey kitten, also 2 adult cats  
DOLBY OVEN 40" Works Female, \$138.88-511  
FEMALE dog, Spayed, show quality  
FREE Electric Range, Free  
FREE Christmas Cards, 250, \$1.50  
FREE Christmas Cards, 250, \$1.50  
FREE Christmas Cards, 250, \$1.50

### 001 Absolutely Free

CHRISTMAS kittens, 6 weeks, \$12.50-15.00  
CLEAN Fil Dirt, You Haul It  
CLOTHING: Howell Church of Christ  
COLD spa refrigerator, no responsibility  
CUTE shorthaired grey kitten, also 2 adult cats  
DOLBY OVEN 40" Works Female, \$138.88-511  
FEMALE dog, Spayed, show quality  
FREE Electric Range, Free  
FREE Christmas Cards, 250, \$1.50  
FREE Christmas Cards, 250, \$1.50  
FREE Christmas Cards, 250, \$1.50

### 010 Special Notices

AIRLINE ticket, Detroit to London  
AIRLINE ticket, Detroit to London  
AIRLINE ticket, Detroit to London  
AIRLINE ticket, Detroit to London

### 015 Lost

ABANDONED cat  
ABANDONED cat  
ABANDONED cat  
ABANDONED cat

### 021 Houses

PREVIEW PROPERTIES  
PREVIEW PROPERTIES  
PREVIEW PROPERTIES  
PREVIEW PROPERTIES

### 021 Houses

PREVIEW PROPERTIES  
PREVIEW PROPERTIES  
PREVIEW PROPERTIES  
PREVIEW PROPERTIES

### 021 Houses

PREVIEW PROPERTIES  
PREVIEW PROPERTIES  
PREVIEW PROPERTIES  
PREVIEW PROPERTIES

### 001 Absolutely Free

CHRISTMAS kittens, 6 weeks, \$12.50-15.00  
CLEAN Fil Dirt, You Haul It  
CLOTHING: Howell Church of Christ  
COLD spa refrigerator, no responsibility  
CUTE shorthaired grey kitten, also 2 adult cats  
DOLBY OVEN 40" Works Female, \$138.88-511  
FEMALE dog, Spayed, show quality  
FREE Electric Range, Free  
FREE Christmas Cards, 250, \$1.50  
FREE Christmas Cards, 250, \$1.50  
FREE Christmas Cards, 250, \$1.50

### 001 Absolutely Free

CHRISTMAS kittens, 6 weeks, \$12.50-15.00  
CLEAN Fil Dirt, You Haul It  
CLOTHING: Howell Church of Christ  
COLD spa refrigerator, no responsibility  
CUTE shorthaired grey kitten, also 2 adult cats  
DOLBY OVEN 40" Works Female, \$138.88-511  
FEMALE dog, Spayed, show quality  
FREE Electric Range, Free  
FREE Christmas Cards, 250, \$1.50  
FREE Christmas Cards, 250, \$1.50  
FREE Christmas Cards, 250, \$1.50

### 010 Special Notices

AIRLINE ticket, Detroit to London  
AIRLINE ticket, Detroit to London  
AIRLINE ticket, Detroit to London  
AIRLINE ticket, Detroit to London

### 015 Lost

ABANDONED cat  
ABANDONED cat  
ABANDONED cat  
ABANDONED cat

### 021 Houses

PREVIEW PROPERTIES  
PREVIEW PROPERTIES  
PREVIEW PROPERTIES  
PREVIEW PROPERTIES

### 021 Houses

PREVIEW PROPERTIES  
PREVIEW PROPERTIES  
PREVIEW PROPERTIES  
PREVIEW PROPERTIES

### 021 Houses

PREVIEW PROPERTIES  
PREVIEW PROPERTIES  
PREVIEW PROPERTIES  
PREVIEW PROPERTIES

### Are You Interested In Selling Real Estate?

If so, give us a call. We offer all the training and marketing tools you need to be successful.

Chuck Fast  
Don Kamen  
Darlene Shemanski

### Century 21

1ST OFFERING: On this custom built 2.1 level on 5 acres in the heart of Howell. Features 3 bedrooms, 1 1/2 baths, family room, country kitchen and breakfast room, 2 car attached garage. 28 x 40 pole building could be used for horses. \$135,900.

### Earl Keim Realty

344-1800  
Each office independently owned and operated.

### Earl Keim Realty

Northville Inc.  
330 N. Center  
New Listing - Spacious 3 bedroom brick ranch on nicely landscaped lot with a desirable Brookings Farms. Call for details. \$135,900.

### Earl Keim Realty

344-1800  
Each office independently owned and operated.

### Earl Keim Realty

344-1800  
Each office independently owned and operated.

### Earl Keim Realty

344-1800  
Each office independently owned and operated.

### Horse Farms Only

A Real Estate Company  
List With Us... Expect Results!  
Happy Holidays!  
(313) 348-4414 (313) 320-3353

### OUTLER REALTY

103-105 Rayson, Northville 349-4030  
PRESTIGIOUS NORTHVILLE AREA  
Brick ranch, full basement, 7 rooms, 2 bedrooms, 2 way fireplace, Florida room off rear, central air/water cleaner, 2nd bath, bedroom suite, lotter, fully carpeted. Immediate occupancy. Call for more details.

### 701 Houses

CAPE GOD IN THE "VANKEE" TRADITION: Three or four bedrooms and three full bathrooms. Attached garage and wood floors. Beautiful "open" space. Large deck and outstanding gazebo, all surrounded by woods and wildlife. Within 2 Lakes. Only \$171,000. Call Cheryl at RE/MAX Suburban, 313-579-1055.

### 701 Houses

HOWELL INCOME PROPERTY  
Remodeled duplex with a great investment cash flow. Each unit is 1,000 sq. ft. Two bedrooms, full appliances. Separate meter. 574.90. Call Marjorie of RE/MAX Suburban, 313-227-4600.

### 701 Houses

HOWELL Small 3 bedroom home (313) 227-4634 after hours, approximately 2 acres. \$70,000. (517) 548-2765.

### Real Estate One

Career Opportunity  
Real Estate training classes starting soon. Call Carolyn Beyer at 313-637-0249 for details.

### NICHOLS REALTY INC.

41074 W. Seven Mile Rd., Northville  
348-3044  
HOME FOR THE HOLIDAYS... and what else!

### GENTRY REAL ESTATE

41074 W. Seven Mile Rd., Northville  
349-1212

### ELGEN REALTORS

PINCINEY Beautiful high setting on five acres. Four bedrooms, 2 1/2 baths, fireplace, walk-out basement, two car garage. Two decks. \$165,000. Nelson Real Estate (313) 449-4466 or Susan (313) 449-4767 or Paul FOWLERVILLE SHOPPING GUIDES will be Christmas week. WEDNESDAY DECEMBER 23RD 10:00 A.M. - 12:00 P.M. DAILY DEC. 23RD 3:30 P.M.

### NOVI AREA

Homes Available For Immediate Occupancy  
Call 349-8737

### Century 21

LYON TOWNSHIP 3 bedroom Ranch on 2.5 acres. Livingroom has built-in bookcase. Deck off rear area. \$166,000, 348-6450.

### Century 21

43133 W. Seven Mile (Highland Lakes Shopping Center) Northville 349-1212

### NOLING REAL ESTATE, INC.

201 S. Lafayette  
437-2056  
522-1556

### HOWELL

Turn of the Century Beauty! Large room, 2 1/2 story home on corner lot with extensive lot. Natural oak woodwork, beveled windows. Unbelievable oak dining room, 4 1/2 bedrooms, Lots of potential! Must see! Priced right at \$85,900. (957)0

### DARLING HOMES

Wixom Office  
349-8737

# Team Up With The Best!

## Work With The People Who Know How To Succeed!

### Merrill Lynch Realty

Outstanding 4 bedroom, 2 1/2 bath Colonial on 10 acres in Salem Township. Circular driveway, new-level fireplace in great living room, kitchen, and fireplace in library and master bedroom. \$190,000. \$100,000 decorating allowance. \$220,000. 478-5000

Beautifully built front home with wooded yard! Beautifully landscaped 3 bedrooms, 2 1/2 bath, large library in lower level, could be 4th bedroom and patio with barbecue grill. Immediate occupancy! \$115,500. 478-5000

NORTHVILLE Tudor exhibits subtle elegance and open floor plan. Includes formal dining room, family room, raised hardwood floors, 4 bedrooms, 2 1/2 baths, library, and 1st floor laundry. Two tier deck and backs to common! \$294,500. 478-5000

COUNTRY SETTING WITH WALKING DISTANCE TO LOW QUALITY FINEST THROUGHOUT THE NORTHVILLE RANCH. Updated kitchen includes granite counters, flooring and cupboards. New garage and charming patio. Wonderfully decorated and immaculately clean! \$115,500. 478-5000

NOVI exhibits a rare find! Luxurious Colonial based private entry and attached garage, 3 bedrooms, 1 1/2 baths, grand room, finished basement, rec room, central air. Deck overlooking common area. \$295,000. 478-5000

BEAUTIFUL FARMINGTON HILLS Colonial! Featuring attractive neutral color throughout, 2 fireplaces, crown moldings, six panel doors and walled-in deck. Also family room, formal dining room, breakfast nook and much more. \$149,900. 628-9100

Spacious FARMINGTON HILLS Tudor offers 4 bedrooms, 2 1/2 baths, library, living room, formal dining room and great room with bar. Tudor architecture with contemporary floor plan. This home includes a natural fireplace, deck, 1st floor laundry and central air. \$185,500. 628-9100

DREAM HOME IN EVERY WAY! Exciting interiors throughout, step-down great room with cathedral ceiling, brick front fireplace and glass French doors opening to 1 1/2 acre lot. 4 bedrooms, 2 1/2 baths, 3 bedrooms, 2 1/2 baths, 3 bedrooms, 2 1/2 baths, 3 bedrooms, 2 1/2 baths. \$218,900. 628-9100

BEAUTIFUL FARMINGTON HILLS Colonial! Featuring attractive neutral color throughout, 2 fireplaces, crown moldings, six panel doors and walled-in deck. Also family room, formal dining room, breakfast nook and much more. \$149,900. 628-9100

### NEW 3 bedroom homes Ranches, Colonials, Tri-Levels Priced from \$69,900 MSHDA's Michigan Mortgages Available. As low as 5% down plus closing costs Ask about our pre-grant opening special

## WELCOME HOMES

(517) 548-3944  
Oakland County Office (313) 674-4153

Directions: South of Fowler St. to Fowler Heights

Novi/Northville - 478-5000  
Farmington Hills - 628-9100  
Birmingham/Bloomfield - 646-6000  
West Bloomfield - 851-8100  
Troy - 689-8900 • Rochester - 651-8850  
Relocation Services • Mortgage Banking - 540-7200

DIRECTIONS: I-66 exit at Pleasant Valley Rd. and turn left. Go to Grand River and turn right. Follow to Old 23 turn right 2 1/2 miles to Skeman Rd. and turn right. Models on right side.



103 Garage & Rummage Sales
ALL GARAGE & RUMMAGE SALES...
104 Household Goods
DRYER: Wards heavy duty electric, runs great, \$55.

105 Firewood and Coal
ACE Stabwood, large 4x4x8, each yields approx. 35 lbs. available from \$4.8.

106 Musical Instruments
107 Miscellaneous
108 Lawn and Garden Care and Equipment
CASE, 300 tractor loader with front loader and backhoe.

109 Lawn and Garden Care and Equipment
110 Building Materials
111 Wood Stoves
112 Household Pets
113 Horse Shows & Equipment

114 Clerical
115 Day-care Babysitting
116 Day-care Babysitting
117 Medical
118 Restaurant

119 Household Pets
120 Horse Shows & Equipment
121 Clerical
122 Day-care Babysitting
123 Medical
124 Restaurant

125 Household Pets
126 Horse Shows & Equipment
127 Clerical
128 Day-care Babysitting
129 Medical
130 Restaurant

131 Household Pets
132 Horse Shows & Equipment
133 Clerical
134 Day-care Babysitting
135 Medical
136 Restaurant

137 Household Pets
138 Horse Shows & Equipment
139 Clerical
140 Day-care Babysitting
141 Medical
142 Restaurant

143 Household Goods
144 Household Goods
145 Household Goods
146 Household Goods
147 Household Goods

148 Household Goods
149 Household Goods
150 Household Goods
151 Household Goods
152 Household Goods

153 Household Goods
154 Household Goods
155 Household Goods
156 Household Goods
157 Household Goods

158 Household Goods
159 Household Goods
160 Household Goods
161 Household Goods
162 Household Goods

163 Household Goods
164 Household Goods
165 Household Goods
166 Household Goods
167 Household Goods

168 Household Goods
169 Household Goods
170 Household Goods
171 Household Goods
172 Household Goods

173 Household Goods
174 Household Goods
175 Household Goods
176 Household Goods
177 Household Goods

178 Household Goods
179 Household Goods
180 Household Goods
181 Household Goods
182 Household Goods

183 Household Goods
184 Household Goods
185 Household Goods
186 Household Goods
187 Household Goods

188 Household Goods
189 Household Goods
190 Household Goods
191 Household Goods
192 Household Goods

193 Household Goods
194 Household Goods
195 Household Goods
196 Household Goods
197 Household Goods

198 Household Goods
199 Household Goods
200 Household Goods
201 Household Goods
202 Household Goods

203 Household Goods
204 Household Goods
205 Household Goods
206 Household Goods
207 Household Goods

208 Household Goods
209 Household Goods
210 Household Goods
211 Household Goods
212 Household Goods

213 Household Goods
214 Household Goods
215 Household Goods
216 Household Goods
217 Household Goods

218 Household Goods
219 Household Goods
220 Household Goods
221 Household Goods
222 Household Goods

223 Household Goods
224 Household Goods
225 Household Goods
226 Household Goods
227 Household Goods

228 Household Goods
229 Household Goods
230 Household Goods
231 Household Goods
232 Household Goods

233 Household Goods
234 Household Goods
235 Household Goods
236 Household Goods
237 Household Goods

238 Household Goods
239 Household Goods
240 Household Goods
241 Household Goods
242 Household Goods

243 Household Goods
244 Household Goods
245 Household Goods
246 Household Goods
247 Household Goods

248 Household Goods
249 Household Goods
250 Household Goods
251 Household Goods
252 Household Goods

253 Household Goods
254 Household Goods
255 Household Goods
256 Household Goods
257 Household Goods

258 Household Goods
259 Household Goods
260 Household Goods
261 Household Goods
262 Household Goods

263 Household Goods
264 Household Goods
265 Household Goods
266 Household Goods
267 Household Goods

268 Household Goods
269 Household Goods
270 Household Goods
271 Household Goods
272 Household Goods

273 Household Goods
274 Household Goods
275 Household Goods
276 Household Goods
277 Household Goods

278 Household Goods
279 Household Goods
280 Household Goods
281 Household Goods
282 Household Goods

283 Household Goods
284 Household Goods
285 Household Goods
286 Household Goods
287 Household Goods

288 Household Goods
289 Household Goods
290 Household Goods
291 Household Goods
292 Household Goods

293 Household Goods
294 Household Goods
295 Household Goods
296 Household Goods
297 Household Goods

298 Household Goods
299 Household Goods
300 Household Goods
301 Household Goods
302 Household Goods

303 Household Goods
304 Household Goods
305 Household Goods
306 Household Goods
307 Household Goods

308 Household Goods
309 Household Goods
310 Household Goods
311 Household Goods
312 Household Goods

313 Household Goods
314 Household Goods
315 Household Goods
316 Household Goods
317 Household Goods

318 Household Goods
319 Household Goods
320 Household Goods
321 Household Goods
322 Household Goods

323 Household Goods
324 Household Goods
325 Household Goods
326 Household Goods
327 Household Goods

328 Household Goods
329 Household Goods
330 Household Goods
331 Household Goods
332 Household Goods

333 Household Goods
334 Household Goods
335 Household Goods
336 Household Goods
337 Household Goods

338 Household Goods
339 Household Goods
340 Household Goods
341 Household Goods
342 Household Goods

343 Household Goods
344 Household Goods
345 Household Goods
346 Household Goods
347 Household Goods

348 Household Goods
349 Household Goods
350 Household Goods
351 Household Goods
352 Household Goods

353 Household Goods
354 Household Goods
355 Household Goods
356 Household Goods
357 Household Goods

358 Household Goods
359 Household Goods
360 Household Goods
361 Household Goods
362 Household Goods

363 Household Goods
364 Household Goods
365 Household Goods
366 Household Goods
367 Household Goods

METRO 25 HOME OF THE TWO-WAY GUARANTEE
METRO 25 HOME OF THE TWO-WAY GUARANTEE
METRO 25 HOME OF THE TWO-WAY GUARANTEE
OFFER ENDS DECEMBER 12TH... ONLY AT METRO 25
Firestone Firestone Firestone
Supreme ASR P185/80R13 Black
P185/75R14 WW
P185/80R13 WS Black
P185/75R14 WS Black
Firestone 721 Radials
Firestone Supreme All Season Radials
Firestone SS Radial

WHAT IS THE BARGAIN BARREL?
If you have an item you wish to sell for \$25, or less...
BABY changing table and high chair, \$35 for both.
BABY turning, infant and toddler, Matching playpen and high chair, Good condition, \$150.
BABY furniture, clothes and crib, 4 pieces, \$100.
BABY furniture, clothes and crib, 4 pieces, \$100.
BABY furniture, clothes and crib, 4 pieces, \$100.

WHAT IS THE BARGAIN BARREL?
If you have an item you wish to sell for \$25, or less...
BABY changing table and high chair, \$35 for both.
BABY turning, infant and toddler, Matching playpen and high chair, Good condition, \$150.
BABY furniture, clothes and crib, 4 pieces, \$100.
BABY furniture, clothes and crib, 4 pieces, \$100.
BABY furniture, clothes and crib, 4 pieces, \$100.

WHAT IS THE BARGAIN BARREL?
If you have an item you wish to sell for \$25, or less...
BABY changing table and high chair, \$35 for both.
BABY turning, infant and toddler, Matching playpen and high chair, Good condition, \$150.
BABY furniture, clothes and crib, 4 pieces, \$100.
BABY furniture, clothes and crib, 4 pieces, \$100.
BABY furniture, clothes and crib, 4 pieces, \$100.

CUT YOUR OWN CHRISTMAS TREE
Scotch Pine • Douglas Fir • White Spruce • White Fir • Balsam Fir
Trees available up to 8 ft.
Trees Priced Individually
COCHOCTA TREE WORKS
Durand Rd., Cochoctaw
Open Saturday & Sunday
10:00 to 5:00

WHAT IS THE BARGAIN BARREL?
If you have an item you wish to sell for \$25, or less...
BABY changing table and high chair, \$35 for both.
BABY turning, infant and toddler, Matching playpen and high chair, Good condition, \$150.
BABY furniture, clothes and crib, 4 pieces, \$100.
BABY furniture, clothes and crib, 4 pieces, \$100.
BABY furniture, clothes and crib, 4 pieces, \$100.

WHAT IS THE BARGAIN BARREL?
If you have an item you wish to sell for \$25, or less...
BABY changing table and high chair, \$35 for both.
BABY turning, infant and toddler, Matching playpen and high chair, Good condition, \$150.
BABY furniture, clothes and crib, 4 pieces, \$100.
BABY furniture, clothes and crib, 4 pieces, \$100.
BABY furniture, clothes and crib, 4 pieces, \$100.





Table of vehicle listings with columns for '225 Autos Wanted', '228 Construction Equipment', '230 Trucks', '233 4 Wheel Drive Vehicles', '239 Antique Cars', '240 Automobiles', and '240 Automobiles'.

BUYING late model wrecks. We have new and used auto parts... HOBART Welders 4 cylinder gas driven zero to 300 amp...

CLASSIFIED DEADLINES: Wednesday 12:00, Green Sheet Shopping Guide, Friday 3:30, Shopper Business Directory, Monday 3:30.

Brighton Chrysler Chrysler Plymouth Dodge Plymouth Dodge 770. 8227 E. Grand River. 229-4100. Ready to Go!

30 IN STOCK FOR IMMEDIATE DELIVERY \$249\*. 88 SNOW COMMANDER 5 7 Prepped and Ready to Go! Brighton Chrysler Chrysler Plymouth Dodge Plymouth Dodge 770.

SAVE OPENSAT 9-5. Rudolph Followed his Nose So Brite-To VARSITY USED CARS. Where Prices Are Right! O - Down. 12 MO./12,000 MILE WARRANTY. NO PAYMENTS 'TIL '88. \$2000 to \$3500. \$5500 to \$6500.

3 MOS. OR 3000 MILES WARRANTY ON OUR USED CARS! '84 Olds Firenza Hatchback. '85 Pontiac 6000. '85 Chevy C-10 Pick-Up. '85 Chevy Caprice Classic. '82 Celebrity 2 Door. '85 Chevy 3/4 Ton Conversion Van. '88 Pontiac Sunbird. '82 Chevy C-10 Pick-Up. '85 Chevy Caprice Classic. '82 Celebrity 2 Door. '85 Chevy 3/4 Ton Conversion Van.

SAVE OPENSAT 9-5. Luxury & Sport. '85 AMC Eagle Wagon. '85 Oldsmobile Cutlass Supreme Brougham Wagon. '81 Crown Victoria. '82 Mercury Grand Marquis LS. '84 Capri RS Turbo. '85 Oldsmobile Cutlass Supreme. '85 Oldsmobile Cutlass Supreme. '85 Oldsmobile Cutlass Supreme. '85 Oldsmobile Cutlass Supreme.

CHAMPION CHEVROLET. FRONT ROW TRUCK SALE. Every Full Size Truck in Our Front Row Is Priced In The Window At Just \$100.00 Over Invoice and includes Bed Liner. 1988 CAVALIERS In Stock \$500.00 Under Dealer Invoice. HURRY! HURRY! HURRY! HURRY! HURRY! HURRY! HURRY! HURRY! HURRY! HURRY!

HILLTOP FORD. NEW MOTOR HOMES. 1986 Travelmaster 23 Ft. Mini Home Double. Air, Self Contained \$19,800. 1986 Travelmaster 24 Ft. Class A Motor Home. Loaded, Sleeps 6, Double Air Wads '81, 1995. \$23,900. INSTANT FINANCING. 72 Month Financing. NO MONEY DOWN.

FREE \$100.00 GIFT CERTIFICATES. Let Us Do Your Christmas Shopping Anywhere You Shop We'll Buy!! 88 COLTS \$6300. DODGE COLT VISTA \$11,500. 1988 DAKOTA 4x4 \$12,200. The LaFontaine Bros. Arbor Dodge. 3665 WASHTENAW • 971-5000. Open Mon., Tues., Thurs. 9-9 - Wed. & Fri. 9-6.

And Just When You Thought There Was No Santa. 1984 Dodge Omni 4Dr., Air. \$2000. 1984 Lynx Sta-Wgn. \$2100. 1984 Dodge Charger Auto, Stereo. \$3300. 1985 Ranger Pick-Up 4 cyl., 4 Spd. \$3900. 1975 Southwind 25 Ft. Motor Home. One Owner, Low Miles. \$4900. 1985 Merc Topaz GS Auto, Air, Stereo. \$4900. 1982 Dodge Window Van Auto, 5 Passenger. \$4600. 1984 Merc Capri RS 5.0, 4 Spd. \$5700. 1983 Cougar v-6, auto., air, stereo. \$5800. 1986 Ford Ranger Pick-Up 4 Spd. \$5700. 1983 Merc GR Marq LS 4 door loaded, Mini Condition. \$6800. 1985 T-Bird v-8, Full Power, Air. \$6900. 1983 Cadillac Seville 4Dr. \$7700. 1984 Olds Toro v-8, Full Power, Tilt, Cruise, Stereo, Very Clean. \$7800. 1986 Dodge 4x4 Pick-Up Auto, P.S., P.B. \$9900. 1986 Mercury Colony Park S/W Loaded. \$9300. 1984 GMC Suburban 4x4 Air, auto., tu-tone. \$9400. 1985 Pontiac Trans-Am T-tops, full power. \$9600. 1986 Mustang Conv. Auto, Air, Stereo, Tilt, Cruise. \$9700. 1986 Bronco II v-6, Auto, Air, Stereo, Still Under Warr. \$9900. 1987 Ford F-150 Pick-Up Super Cab 4x4. \$11,400. 1987 Ford E-250 Club-Wgn 12 Pass., 6 Cyl, Air, Auto. \$12,800.

ARE WE HAVING FUN YET? For the survivors of a flood, life is anything but fun. If you can't spare even a few dollars to help... you ought to be ashamed. American Red Cross.

# WHY YOU SHOULD BUY A SUPERIOR USED CAR...

**We Pay The Sales Tax**  
On All Used Cars & Trucks Sales From Dec. 9th to Dec. 31st

**1987 Voyager** \$12,900  
7 pass., 14,000 miles, air

**1986 Olds Ciera 4 Dr.** \$8995  
5,000 miles

**1985 Olds Ciera** \$6995  
V-6, auto., air

**1985 Chrysler Fifth Ave** \$7,495

**1987 Bonneville** \$14,500  
4 Dr., 2,000 miles

**1987 Cadillac Sedan Deville** SAVE

**1986 Olds Ciera Brougham** \$8995  
4 Dr.

**1986 Olds Ciera Wagon** \$9695  
13,000 miles

**1985 Celebrity** \$9695  
4 Dr.

**1985 Monte Carlo** \$7995

**1985 Celebrity** \$6995  
4 Dr.

**1985 Buick Somerset** \$7495  
Auto., A/C, 20,000 miles

**1985 Olds Custom Cruiser** \$7495

**1985 Olds 88** \$8995  
4 Dr.

**1985 Toronado** \$9995  
Last of Big Ones

**1984 Chevette** \$2995  
4 Dr., auto.

**1985 S-10 4x4** Short Box Sharp

**1986 Chevy S-10 4x4** 5 speed, Air, Ext. Air

**1985 Chevy S-10 Blazer 4x4** Automatic, Air, V-6

**1984 Chevy S-10 4x4 Blazer** Automatic, Air, V-6

—OTHER TRUCKS INCLUDE—

**1986 S-10 Pickup** \$7995  
Auto., air

**1985 Ranger Pickup** \$5995

**1983 Ford F-100 Pickup** \$4995

**1986 Ford XL 1/2 Ton** \$9995  
Auto., V-8

**1985 S-10 Pickup** \$6995  
Air, auto.

**1984 Beauville Van** \$9495  
V-8, auto.

**Inside Display**

OPEN SAT. 9-2  
Over 60 Units in Stock  
Experienced Sales Staff To Serve You  
On The Spot Financing - MRP Warranty  
Available On Used Cars, Backed By GM

Jack Jeffreys Bill Mangan  
Russ Tell  
**SUPERIOR**  
Olds Cadillac GMC  
1-96 Exit 145  
Brighton 227-1100

SAVE SAVE SAVE SAVE SAVE

# McDONALD FORD

## HUGE Winter Clearance

### THERE'S A SAVINGS BLIZZARD AT OUR USED CAR LOT

<b>1980 Fiesta</b> Clean	<b>1984 Mustang</b> Loaded
<b>\$1999*</b>	<b>\$5999*</b>
<b>1985 Tempo 4 Dr GL</b> Loaded	<b>1985 Escort</b>
<b>\$5999*</b>	<b>\$2999*</b>
<b>1984 T-Bird</b>	<b>1986 Ranger Pick-Up XL</b> V-6
<b>\$5999*</b>	<b>\$5999*</b>
<b>1986 Mercury XR3</b>	<b>1985 EXP</b> Air, Loaded
<b>\$6999*</b>	<b>\$4999*</b>
<b>1984 Mazda Pick-Up SE5</b> Air	<b>1984 Mustang</b> Auto, Air, V-6
<b>\$3999*</b>	<b>\$4999*</b>
<b>1974 Mercedes Benz 280</b> 4 Dr., Air, Auto, Very Clean	<b>1981 Crown Victoria</b> Loaded, Low Miles
<b>\$5999*</b>	<b>\$4999*</b>

Conveniently Located

**McDONALD FORD**  
550 W. 7 Mile  
**NORTHVILLE**  
Between Northville Road & Sheldon Road  
One Block East Of Northville Downs

**349-1400**  
\*plus tax, title and license

### HERE'S A LIST OF VOLKSWAGEN DEALERS THAT WILL SELL YOU A NEW VOLKSWAGEN FOR LESS THAN TOM SULLIVAN...

- 1) 1977 TOYOTA Corolla. Excellent transportation. Very reliable. Runs great. \$500. (517) 548-3744.
- 2) 1978 CHEVY G-10 van. Fair condition. Lots of new parts. \$600. (313) 271-9571 between 6 p.m. and 9 p.m.
- 3) 1978 CHEVETTE. No rust. new brakes. tinted chain air. For parts. Best offer. (313) 227-2189.
- 4) 1978 CHRYSLER New Yorker. one owner, very clean. \$795. (313) 878-6478.
- 5) 1978 FORD Fiesta. Good condition, good transportation. \$550. (313) 227-9488.
- 6) 1978 MALIBU. Many options. Best offer. (313) 227-1925.
- 7) 1978 NOVA. 4 door, needs transmission, has extra radiator and starter. Make offer. (313) 878-6534 after 5 p.m.
- 8) 1978 PLYMOUTH Arrow. 4 cylinder. Runs good. Low mileage, some rust. \$290. (517) 548-4996.
- 9) 1978 TRANS AM, needs minor engine work. \$500 or best offer. (313) 437-3185.
- 10) 1979 DATSUN 210. \$750. (517) 548-7835 a.m. or (517) 548-3182 p.m.

BEFORE YOU BUY OR LEASE ANY VOLKSWAGEN AT ANY PRICE FROM ANYONE FOR ANY REASON, Come See Tom Sullivan.

OPEN SATURDAYS 353-6900

25400 W. 8 Mile Rd. Between Telegraph and Grand River  
**TOM SULLIVAN VOLKSWAGEN**

## BRIGHTON CHRYSLER USED CARS IN HOWELL!

TEDD PLESS - Used Car Manager

84 Mercury Topaz G.S. 4 door auto air	85 Chrysler Caravan Loaded	85 Dodge Caravan 7 pass., auto., air	86 Renault Alliance Auto. air
<b>\$4795</b>	<b>\$5795</b>	<b>\$7995</b>	<b>\$5795</b>
<b>82 Dodge B-250 Van</b> 8 passenger, loaded			
<b>\$4495</b>			
81 Buick Regal Auto., air	84 Buick Electra Station wagon, loaded	82 Chevrolet Conversion Van Excellent condition	84 Ford F150 P/U
<b>\$3495</b>	<b>\$6200</b>	<b>\$6995</b>	<b>\$5200</b>

JUST IN TIME FOR WINTER

76 FORD RANCHERO	77 DODGE FULL SIZE P/U	82 FORD ESCORT
<b>\$995</b>	<b>\$895</b>	<b>\$4490*</b>

904 E. Grand River - Howell  
**(517) 548-5190**

## NOW IS THE TIME TO BUY

# 1.9% APR Financing\*

### 300 New Cars & Trucks (A Great Selection - Select Vehicles Only)

## WE PAY YOUR SALES TAX

**SPECIAL HOURS OPEN 9:00 to 9:00 Monday, Tuesday, Wednesday & Thursday**

SAVE EVEN MORE... Use Your GM Rebate - GM Employee - Option 2-0

**MARTY 348-7000** WE'RE CLOSE TO HOME!  
**JAY 684-1025**

42355 GRAND RIVER  
Just East of Novi Road, Novi  
Open Monday thru Thursday 9-9

2675 N. MILFORD ROAD  
MILFORD - HIGHLAND  
Open Monday thru Thursday 9-9

### 241 Vehicles Under \$1000

1981 FORD Farmington station wagon, 4 cylinder, 4 speed. New transmission, rear defrost, new tires. Good condition. \$700. (313) 227-9488.

1982 CHEVETTE, four door, air, four speed, am, new tires, rear defrost, good condition. \$990. (313) 895-3005.

1982 DODGE Diplomat. Fully loaded, power. \$1,200. After 5 p.m. (517) 232-9521.

1982 FORD Escort. Runs and drives excellent. Rear body damage \$500. (517) 548-4375.

1985 GMC Suburban. Like new, fully loaded, 3rd rear seat, 40,000 miles. \$10,900. (313) 895-3197.

1985 TOPAZ GS, 4 door, air, am/fm stereo cassette, new tires. \$4,900. (313) 895-3757.

BUYING late model wrecks. We have new and used auto parts. New radiators at discount prices. Michigan Auto Salvage Inc., Howell. (517) 846-4111.

WANTED: 1976 to 1980 Volare or Regent, 4 door, 8 cylinder, automatic, good condition. No dealers. (313) 229-8406.

215 Computer Sales & Services  
COMPLETE driveway service. Repairs and detailing. Free estimates. Call Jeff. (313) 437-9937.

FARMINGTON HILLS  
**SELECT USED CARS**  
1986 NEW YORKER  
Top, Loaded, 17,000 Miles, Must See!  
1985 VOYAGER LE  
White, Wood Grain, Air, Good  
1984 FORD XLT  
Black & Silver, V-8, 31,000 Miles, Price Low To Go!  
1987 OMI  
4 Door, Air, Automatic, Power Steering and Brakes, Cloth, AM-FM Stereo, Low Miles, Price To Sell!  
1983 CIRRORON  
Leather, Loaded, Low Miles, '95  
1984 FIRENZA  
4 Door, Loaded, Only 34,000 Miles, More.  
1987 FIFTH AVENUE  
Silver, Air, Loaded, "PRICED TO SELL"  
1986 LASER  
Air, Automatic, 16,000 Miles, Price To Sell!

Many More to Choose From  
FARMINGTON HILLS  
CHRYSLER-PLYMOUTH  
531-8200

# Bill Cook

## THE BEST DEALER IN FARMINGTON HILLS

BUICK AUCI PORSCHE MAZDA

### "WHOLESALE BUDGET LOT"

WE HAVE NEW & USED TRADE-INS YOU'LL SAVE THOUSANDS!! Example

'86 FORD RANGER PICKUP 5 speed, AM/FM stereo, custom wheels & tires, only 17,000 miles. <b>\$6995</b>	'81 CHEVY MALIBU Air, Stereo, Full Factory Equipment <b>\$2295</b>	'80 TOYOTA SRS COROLLA 5 speed, air conditioning, stereo, only 5,000 miles. <b>\$2295</b>	1985 GRAND AM Air, stereo cassette, tilt, power steering and brakes <b>\$6695</b>
'85 OLDSMOBILE CUTLASS CIERA Air, stereo, tilt, cruise, "Leads with Options" <b>\$4995</b>	'85 CENTURY LIMITED WAGON 3 V-6, 3rd seat, air conditioning, stereo cassette, low miles. <b>\$6995</b>	'87 CHEVY SPIN 4 door, automatic, stereo cassette, full factory equipment, only 8000 miles. <b>\$6695</b>	1983 BUICK LESABRE LIMITED V-6, air, stereo, tilt, power windows and door locks, wire wheels <b>\$3395</b>
'86 FORD TEMPO GL Auto, air, tilt, cruise, stereo cassette, door, window, low miles. <b>\$5995</b>	1985 PLYMOUTH RELIANT 2 DOOR Automatic, air, stereo, power steering and brakes, low miles, and clean <b>\$4495</b>	'84 CHEVETTE 4 DOOR Auto, air, power steering and brakes, stereo, low miles, "Price Ready" <b>\$2995</b>	'85 TOYOTA COROLLA 4 door, automatic, air conditioning, power steering, power windows, stereo, more <b>\$5995</b>
'82 SKYLARK LIMITED 4 door, automatic, air conditioning, tilt, stereo and low miles. <b>\$3495</b>	'82 CHEVY MONTE CARLO Air, power windows and door locks, tilt, cruise, stereo, low miles. <b>\$4495</b>	1985 MAZDA GLC 4 DOOR Auto, air, power steering and brakes, stereo, low miles, full factory equipment <b>\$4695</b>	'84 VOLKSWAGEN SCIROCCO 5 speed, air, stereo, power steering and brakes, low miles <b>\$5995</b>

OVER 50 CARS AT SIMILAR SAVINGS!  
37911 GRAND RIVER FARMINGTON HILLS **471-0800**  
"ASK FOR THE BUDGET LOT"

## SANTA REBATE SAVERS



WILSON FORD & MERCURY

**\$600 CASH ALLOWANCE** ON T-BIRDS - COUGARS - SABLE - TAURUS

**\$400 CASH ALLOWANCE** ON ESCORTS & TRACERS

•See Salesman For Details

### Ford A-1 USED CARS and TRUCKS

1983 FORD CROWN VICTORIA Deluxe Interior, Fully Loaded <b>\$5495</b>	1988 CAPRI 3 Door SPECIAL auto, Air, And More <b>\$6995</b>
1984 LTD 4 Door V-8, Auto Trans, And More <b>\$5995</b>	1985 LTD WAGON SQUIRE Well Equipped SPECIAL <b>\$4995</b>
1986 VAN CONVERSION 10,000 Miles, T.V., Deluxe Trim, Fiberglass Running Boards <b>\$15,595</b>	1984 TOPAZ With Sport Wheels <b>\$4295</b>
1982 GRANADA Auto Trans, Air <b>\$2995</b>	1987 F-250 4x4 PICKUP Air, XLT Trim, Power Windows, Power Locks, And Much More <b>\$14,995</b>

WILSON FORD & MERCURY  
8704 W. Grand River • Brighton • 227-1171  
Open Mon. & Thurs. evens. \*'til 9; Saturdays 10-2

# Low Price Zone

## YOUR SANTA DESERVES A NEW SLEIGH

### USED CARS

87 CHEVY SPECTRUM CL 4 cyl, air, radio, tinted glass <b>\$6950</b>	87 CHEVY CORSICA 4 cyl, auto, air, stereo and more. Best Deal in Town <b>\$8995</b>	87 OLDS CIERRA Leather interior, tilt, cruise, air, stereo, p. windows, p. locks, p. seats, SHARP <b>\$10,900</b>	85 BUICK SKYHAWK 2 dr, auto, p.s., p.b., air, stereo <b>\$5995</b>	84 CAPRICE STATION WAGON Full power, 9 pass., ready for the whole family. <b>\$6995</b>	86 FIERO 4 cyl, 5 spd., air, stereo and more <b>\$6995</b>	86 OLDS CALAIS 4 dr, 4 cyl, auto, air, stereo, p. locks, low miles <b>\$7995</b>	87 DODGE CHARGER 4 cyl, 4 spd., custom interior, AM/FM stereo <b>\$5995</b>	87 GRAND AM L/E 6 cyl, auto, air, stereo (tape), p. windows, p. locks. <b>\$4995</b>	84 FORD LTD V-6, auto, air, stereo and more <b>\$4995</b>	84 REGAL LIMITED 4 door, beautiful, black cherry finish-loaded with equipment <b>\$5950</b>	85 PARK AVENUE 2 To Choose From both loaded with extras-drive in style-your choice <b>\$9900</b>	85 SOMMERSET Full power, astro roof, excellent condition <b>\$6900</b>	85 BUICK CENTURY LIMITED Air, stereo, p. locks, a clean one owner car <b>\$6995</b>
--	---	---	--	---	--	--	---	--	---	---	--	--	---

### BARGAIN NEW CARS

87 PONTIAC FIERO  
Stereo, with cassette, fuel injection, sunroof, aluminum wheels and more!  
Stk. No. 695  
Was \$9923 **\$7996\***

1987 NEW BUICK LESABRE 4-DOOR  
Was \$15,171 **\$11,571\***

1987 NEW BUICK PARK AVENUE 4-DOOR  
Luxurious style, full power, plus vinyl carpet roof Was \$12,240, Stk. No. 745 **\$15,478\***

1987 NEW & DEMO PONTIAC 4-DR. BONNEVILLE  
10 to choose from. All with 3.8 litre S.F.I., air, tilt, automatic, stereo, tilt & much more., Stk. No. 699 **\$10,978\***

1987 NEW & DEMO PONTIAC 6000's  
9 to choose from, 2 doors, 4 doors, all with fuel injection, automatic, air, tilt, delog., stereo & much more., Stk. No. 755 **\$9485\***

GM OPTION! OUT OF STOCK  
Purchases & Suppliers Welcome Hurry, Offer Ends Soon!

### TRUCKS!!!

1984 GMC S-15 JIMMY Tahoe package, fully equipped, tu-tone, 4x4, includes new western snow plow <b>\$9495</b>	1985 S-10 BLAZER Tahoe pkg., loaded with options, low miles, tu-tone paint, 4x4 <b>\$11,495</b>	1987 S-10 BLAZER Tahoe pkg., lots of equipment, aluminum wheels, like new, 4x4 <b>\$14,900</b>
1986 GMC 4x4 PICK-UP Scottsdale pkg., ready for winter work or play, this truck's a gem <b>\$11,995</b>	1985 GMC 4x4 PICK-UP High Sierra, tilt, cruise, air, stereo, p. windows & locks, fiberglass top, X-tra clean <b>\$10,995</b>	1986 CHEVY PICK-UP Silverado pkg., all the options, tu-tone paint. Two to choose from <b>\$10,495</b>
1977 SHASTA 22 FT. MOTOR HOME One owner, low miles, fully self contained, everything works <b>\$8495</b>	1986 GMC SIERRA PICK-UP Tu-tone paint, V-8, auto, p.s., p.b., topper <b>\$8995</b>	1985 CHEVY BEAUVILLE 9 pass., rear heat, rear air, loaded, tu-tone <b>\$10,900</b>
1981 JEEP C/7 6 cyl, 4 spd. <b>\$3500</b>	1985 FORD F-350 XL DUALLY 48 V-8, tilt, cruise, air, stereo, p. windows, p. locks, chrome wheels <b>\$12,900</b>	1986 FORD F-250 XLT LARIET PICK-UP 6.9 diesel, loaded, lighted running boards, bed liner, you have to see it! <b>\$12,900</b>
1985 GMC SIERRA CLASSIC PICK-UP 20,000 easy miles, loaded with options, this truck's been pampered <b>\$9995</b>		

\*Plus Destination, Tax, Title & Plates

# WALDECKER

## PONTIAC - BUICK

785 W. GRAND RIVER • BRIGHTON MI • 227-1761

OPEN MON & THURS 9 to 9  
TUES, WED., FRI 9 to 6  
SATURDAY 10 to 3

Waldecker

GM QUALITY SERVICE PARTS  
GENERAL MOTORS PARTS DIVISION  
Mr. Goodwrench

**SAVE SAVE SAVE SAVE SAVE SAVE SAVE SAVE SAVE SAVE SAVE**

# McDonald Ford

**Our Lots Are Full & More Cars & Trucks Are Coming  
WE MUST MOVE 'EM OUT NOW!!!**

**THESE CARS & TRUCKS ARE LOADED! PRICES INCLUDE ALL OPTIONS**

<p><b>'88 RANGER</b></p>  <p>4 Cyl. Engine Fold Away Mirrors Removable Tailgate Custom Trim Coat Hook Cigarette Lighter Flow through Ventilation Color Keyed Visor Locking Glove Box</p> <p>5 Spd. O.D. Argent Styled Wheels Gauge Package All Season Radial Tires Dome Light Insulated Floor Mat Day/Night Mirror Scuff Plates Too Much More To Mention</p> <p>Was \$7288 Discount \$489 Rebate \$500</p> <p><b>NOW \$6299*</b> Stk. No. 8316</p>	<p><b>'88 MUSTANG GT</b></p>  <p>5.0 Liter V-6 Air Conditioning Power Locks Power Steering Tilt Wheel Electric Defroster Dual Remote Mirrors Sports Seats Instrumentation</p> <p>Automatic Power Windows Power Brakes Cruise Control Electronic AM/FM Stereo Cassette Premium Sound System Cast Spoke Wheels Light Group Trac-Loc Axle</p> <p>Was \$15,673 Discount \$1674</p> <p><b>NOW \$13,999*</b> Stk. No. 8097</p>	<p><b>'88 CROWN VICTORIA LX</b></p>  <p>302 V8 Power Windows Power Locks Power Brakes Cruise Control Cast Aluminum Wheels Vinyl Roof Vent Windows Tinted Glass</p> <p>Automatic Power Seat Power Steering Air Conditioning Tilt Wheel Rear Defroster Luxury Cloth Split Bench Seat AM/FM Stereo Clock</p> <p>Was \$18,098 Discount \$3099</p> <p><b>NOW \$14,999*</b> Stk. No. 8282</p>	<p><b>'88 TAURUS GL</b></p>  <p>V6 Engine Air Conditioning Power Steering Full Size Spare Tilt Wheel Electric Defroster Rocker Moldings Cloth Split Bench Seat AM/FM Stereo</p> <p>Automatic Power Locks Power Brakes Front Wheel Drive Cruise Control Light Group WSW Tires Child Safety Locks Interval Wipers</p> <p>Was \$14,901 Discount \$2002 Rebate \$1100</p> <p><b>NOW \$11,799*</b> Stk. No. 8262</p>
<p><b>T-BIRD TURBO</b></p>  <p>Was \$20,096 Discount \$4597</p> <p><b>NOW \$15,499*</b> Stk. No. 71326</p>	<p><b>ESCORT 2 DOOR</b></p>  <p>Was \$7755 Discount \$756 Rebate \$700</p> <p><b>NOW \$6299*</b> Stk. No. 71275</p>	<p><b>ESCORT WAGON</b></p>  <p>Was \$9428 Discount \$1529 Rebate \$700</p> <p><b>NOW \$7199*</b> Stk. No. 7473</p>	<p><b>MUSTANG GT CONVERTIBLE</b></p>  <p>Was \$18,512 Discount \$1513</p> <p><b>NOW \$16,699*</b> Stk. Demo 71145</p>



## McDONALD FORD

CONVENIENTLY LOCATED  
**550 W. 7 Mile Road**  
Between Northville Road & Sheldon Road  
One Block East of Northville Downs

**349-1400**

\*Plus Tax, Title, Destination and Assignment of Rebate to McDonald Ford

**NORTHVILLE**

**SAVE SAVE SAVE SAVE SAVE SAVE SAVE SAVE SAVE SAVE SAVE**

the NOVI NEWS

# Living

**WINTER SPORTS:**  
Parks and Rec cities  
winter recreation sites/2C

**TREE TIPS:**  
Tips for selecting  
perfect Christmas trees/3C

**MAKE YOUR OWN:**  
Tempting recipes for  
true chocolate lovers/8C

**LOCAL GETAWAYS:**  
Weekend resorts  
aren't far from home/7C

**1C**

THURSDAY  
December 10,  
1987



# Chocolate

**It's love at first bite**

*Story by Lora Helou ■ Photography by Scott Piper*

**Who says chocolate isn't good?**

Mom always told you it would cause acne, right? Ha! That's just one of the many misconceptions about chocolate. In fact, there are several facts about the health and nutritional value of chocolate you'd probably find surprising. For example:

- **Acne?** Chocolate, indeed, does not cause acne. In fact, the Federal Drug Administration has reported that acne is not diet-related, but is probably caused by hormonal changes at puberty. Because quite a few teenagers are chocoaholics, the myth was born that chocolate was causing all that acne.
- **Sugar?** It's true that chocolate contains sugar, and sugar helps cause cavities. But did you also know that chocolate contains some substances which are good for your teeth? It's true. Researchers say there are several chemicals in cocoa which actually inhibit the bacterial action that promotes cavities and plaque.
- **Caffeine?** Worried about eating chocolate because of its high caffeine content? Worry no longer. The average one-ounce chocolate bar only contains five to seven milligrams of caffeine. Compare that to the 90-150 milligrams in a cup of coffee, or the 40-50 milligrams found in a soft drink. So if you're trying to stay awake all night studying for that big test, don't think that eating 10 Hershey bars will do the trick.
- **Fattening?** Forget the fact that you consider it unhealthy. Perhaps you're shying away from chocolate simply because you don't want to eat anything that fattening. Instead, you figure you'll have, say, a nice cup of yogurt. Surprise! On the average, a chocolate bar contains fewer calories than a cup of yogurt.
- **Vitamins?** Keeping track of your vitamin intake? Consider this: The average 1.5-ounce chocolate bar contains more protein, riboflavin, calcium and iron than a medium-sized apple.

*Continued on 4*

---

## Sweet Pursuit

**Seeking the ultimate chocolate**

*Story by Phil Jerome*

"I've got a problem," she said. "You've come to the right place, lady," I replied. "What is it? Husband playing around? Want me to put a tail on him? See what he's up to?"

She was dressed real nice. Gucci handbag. Nina Ricci perfume. A real yuppie type.

"No, no. It's nothing like that," she said, depositing her shapely frame into one of my tattered chairs.

"The problem is that we're having a party. An important party. My husband's having some of his associates over next week and it's really important that we make a good impression. It means a lot to him and it's important to his career."

"That's very nice," I responded. "But I don't see the problem. And I don't see what it has to do with me."

"Here's the thing," she said. "I want to serve the best wines, the best caviar. . . you know."

It means a lot to him and it's important to his career."

"That's very nice," I responded. "But I don't see the problem. And I don't see what it has to do with me."

"Here's the thing," she said. "I want to serve the best wines, the best caviar. . . you know."

Like I said, she was tall and thin with those great legs. And she looked and sounded a little desperate.

*Continued on 5*

# Don't Miss It!

## MONDAY GREEN SHEET

**"Chocked Full" of Values  
from Your Favorite Retailers & Food Stores**

**Delivered to over 49,000 homes  
in Livingston County, South Lyon & Milford Areas**

**Reach This Growing Market With Your Classified Ad**

**Monday Green Sheet**

Delivered to over 49,600 homes in Livingston County and the South Lyon and Milford areas.

Free

**To place your classified ad:**

Brighton, Pinckney or Hartland	(313)227-4436
Howell/Fowlerville	(517)548-2570
South Lyon area	(313)437-4133
Milford area	(313)685-8705

# Parks and Rec reports winter recreation sites

By JEANNE CLARKE special writer

Novi residents can take advantage of numerous winter sports facilities operated by the Novi Parks and Recreation Department. The department is scheduled to move into new offices at the Novi Civic Center on Monday, Dec. 14, at 8 p.m. The new telephone number for Parks and Recreation will be 347-0400.

Two ice skating rinks are available behind the tennis courts at Ella Mae Power Park on Ten Mile. One rink is available for general skating, while the second is reserved for hockey.

Cross-country ski trails are available at both Power Park and Lakeshore Park. There is a marked two-mile trail at Power Park; there are no marked trails at Lakeshore Park.

Sledding and tobogganing facilities are available at Lakeshore Park, although supervision is not provided. There is also a community room with a capacity of 40 people at Lakeshore. Winter hours at Lakeshore Park are 8 a.m. to sunset depending on weather conditions.

The Parks and Recreation Department has established a Santa Hotline at 349-1940 during the holiday season. Youngsters may call from Monday, Dec. 14, to Thursday, Dec. 17, from 2 to 4 p.m. and talk with either Santa or Mrs. Claus.

Several cross-country ski clinics will be offered this winter at Maybury State Park on Eight Mile between Back and Napier roads. The first clinic will start Saturday, Dec. 12. Subsequent clinics will be offered in January and February. Call 349-1976 for details.

An organizational meeting for the Over-30 Men's Basketball League will be held at the Novi Civic Center on Tuesday, Dec. 15, at 6:30 p.m. Registrations are being accepted for youngsters in grades 3-8 who want to play floor hockey. Registration deadline is Dec. 18. Call 349-1976 for more information.

VOICE: Village Oaks Elementary School will hold its annual Family Sing-along tonight (Thursday, Dec. 10). Parents are asked to bring canned goods for needy families instead of the usual log for the fire. The Sing-along will be held in the gym this year, and there will be hot chocolate and goodies following the singing. The singing will be led by a group called the "Urban Suburbs."

## Novi Highlights

Students will attend an assembly presented by the Redford Bell Ringers on Wednesday, Dec. 16, at 2 p.m.

THE VOICE board will not meet in December. The next meeting will be held at the school on Jan. 11.

NEWCOMERS CLUB: The Novi Newcomers Club has scheduled a variety of activities during the holiday season, including the annual Bubbling Champagne Brunch on Sunday, Dec. 13. Call Barb Widrig for details.

Other holiday activities include a cookie and candy exchange throughout the month. Coming up Dec. 20 is a Yuletide Evening at Greenfield Village.

Upcoming family activities include a trip to see "Peter Pan" at the Marquis Theater in Northville on Dec. 27 and a trip to see "Snow White and the Seven Dwarfs" later in the month.

The Newcomers also are planning to attend the annual Plymouth Ice Sculpture Festival. Car pooling will be available. Also planned is a roller skating trip at the Riverside Roller Arena in Livonia in January.

Anyone interested in making new friends regardless of how long they've lived in Novi is invited to learn more about membership in the Newcomers Club. A "New Members Tea" will be held early in January to inform prospective members about club activities.

The Newcomers sponsor "Special Interest" groups designed to provide a wide range of activities. Interest groups include Needlecrafters, Mom and Tot Stitches! Time, Euchre, Crafts, Daytonie Bridge, Evening Bridge and Couples Bridge. The Out-to-Lunch group is planning a trip to Carlton's in Brighton. Another trip is being planned for the Premier Center Night Club in Sterling Heights.

GIRL SCOUTS: The Novi Girl Scout council this year and would like to thank the residents of Novi for their support. Sixty cents from the sale of every calendar is placed in the treasury to fund Girl Scout activities.

Girls in Junior Troop 3842 led by Kathy Langham, Patti Kearney and

Agape Singers Club has scheduled a variety of activities during the holiday season, including the annual Bubbling Champagne Brunch on Sunday, Dec. 13. Call Barb Widrig for details.

Other holiday activities include a cookie and candy exchange throughout the month. Coming up Dec. 20 is a Yuletide Evening at Greenfield Village.

Upcoming family activities include a trip to see "Peter Pan" at the Marquis Theater in Northville on Dec. 27 and a trip to see "Snow White and the Seven Dwarfs" later in the month.

The Newcomers also are planning to attend the annual Plymouth Ice Sculpture Festival. Car pooling will be available. Also planned is a roller skating trip at the Riverside Roller Arena in Livonia in January.

Anyone interested in making new friends regardless of how long they've lived in Novi is invited to learn more about membership in the Newcomers Club. A "New Members Tea" will be held early in January to inform prospective members about club activities.

The Newcomers sponsor "Special Interest" groups designed to provide a wide range of activities. Interest groups include Needlecrafters, Mom and Tot Stitches! Time, Euchre, Crafts, Daytonie Bridge, Evening Bridge and Couples Bridge. The Out-to-Lunch group is planning a trip to Carlton's in Brighton. Another trip is being planned for the Premier Center Night Club in Sterling Heights.

GIRL SCOUTS: The Novi Girl Scout council this year and would like to thank the residents of Novi for their support. Sixty cents from the sale of every calendar is placed in the treasury to fund Girl Scout activities.

Girls in Junior Troop 3842 led by Kathy Langham, Patti Kearney and

Agape Singers presented their "USO Can-

ship in American Legion Post 19 is available by calling the post home at 476-6348 or Ken Bell at 6684.

BEVERLY MANOR: Activity Director Jill Dillsworth is looking for volunteers to visit Beverly Manor residents and help their lives a little brighter during the holiday season.

A volunteer is needed to teach a crafts class that was eliminated due to staffing cutbacks. Also needed are young people to participate in the "Adopt a Grandparent" Program.

The program is ideal for young families which do not have grandparents in the general area because it enables children to enjoy a relationship with older adults.

Also needed are volunteers who can plan piano for a regular singing program and a retired school teacher who can provide an educational program in basic math, English and history.

Mr. and Mrs. Dave Stanley and their children attended the wedding of their cousin Kimberly Mayes, to Larry Atkins. They were accompanied by Mrs. Hooper Fenton. Before returning home they visited the First Baptist Church in Hammond, Indiana, where more than 7,500 people were present to celebrate the 100th Anniversary of the church. The Rev. Jack Hayes is pastor of the church.

PERSONALS: Weekend guests at the home of Mr. and Mrs. Ron and Mary Ann Sinders of Alexandria, Louisiana. The Sinders were former classmates at Menard Academy and were part of the 1956 graduating class.

Mr. and Mrs. Burton and their children Tracy, Tiffany and Benjamin have returned from Kokomo, Indiana, where they visited both sets of grandparents. Mr. and Mrs. Jim Cato and Mr. and Mrs. Walter Burton.

Jody and Jason Roder, both students at the Stepping Stone Center for Gifted Children in Northville, visited the University of Michigan campus where they toured wind tunnels and a helicopter pad in conjunction with a science project. They are the children of Max and LaRita Roder.

David Speight of Los Angeles visited his parents, the Rev. and Mrs. Ivan Speight, for the Thanksgiving holidays.

Mr. and Mrs. Dave Stanley and their children attended the wedding of their cousin Kimberly Mayes, to Larry Atkins. They were accompanied by Mrs. Hooper Fenton. Before returning home they visited the First Baptist Church in Hammond, Indiana, where more than 7,500 people were present to celebrate the 100th Anniversary of the church. The Rev. Jack Hayes is pastor of the church.

The Turkey Raffle netted \$35 which will be placed in the activity fund. Beverly Manor residents also completed their fall bazaar with proceeds earmarked for materials for upcoming projects.

Armine Messalian won a contest to guess when the first snow would fall this winter. Her winning entry was Nov. 20.

Novi American Legion Post 19 is available by calling the post home at 476-6348 or Ken Bell at 6684.



Novi News/PHILIP JEROME

### Quest for flight?

No, two-year-old David Bendmergel isn't really trying to tempt gravity. It's just that the youngster is fascinated by balloons. And when several were left over at the end of the Meadowbrook Glens Homeowners Association Christmas party last Thursday, David decided he would like to take a few extra home with him.

### Healthy snacking can have benefits

By design or default, the snacking habit is a very real part of the American pattern of life. The sociability and satisfaction derived from coffee breaks, T.V. nibbles or preschool snacks all point to the fact that a multi-meal eating plan is desired and here to stay.

"Many people associate snacking with eating high-calorie, low nutrient foods," says Linda Cornell, Oakland County Home Economist. "For about 20 percent of us, snacks provide 20 percent of the day's caloric and other nutritional needs."

Even teens benefit from snacking. Their snack choices were found to be high in vitamins A and C, calcium and magnesium. Some of the foods that adolescents choose regularly were frozen fruit bars, yogurt and chocolate sandwich cookies and milk.

One of the peak snacking times for many children is immediately after school. With planning, parents can assure that a variety of foods that are high in nutrients are available for preschool snacks all point to the fact that a multi-meal eating plan is desired and here to stay.

Try to avoid eating sweets for snacks. Remember that foods aren't good or bad by themselves. A few cookies taste great with a glass of milk, and an occasional chip is not going to harm an otherwise balanced diet.

For more information, contact the Food Preservation/Food Safety Hotline, 888-9004, Oakland County Cooperative Extension Service.

# Tips on picking Christmas trees

No one scene embodies the warmth and spirit of Christmas more than the entire family gathered around a beautifully and lovingly decorated Christmas tree.

When shopping for a Christmas tree, many of us spend hours looking for that "perfect" tree. But is there a "perfect" Christmas tree? Not really.

Practically all kinds of evergreens can be used as splendid Christmas trees. But each type of tree has its own characteristics and only personal tastes can determine which tree is right for you.

"A few simple guidelines can make the selection of the 'perfect' Christmas tree easier and help you avoid some of the problems associated with Christmas tree buying," said Wayne Nierman, County Extension Director of Oakland County Cooperative Extension Service.

The following are recommended guidelines to help you find the size and type of Christmas tree that is right for you:

- Before shopping, determine

**Nierman: 'A few simple guidelines can make the selection of the perfect Christmas tree easier and help you avoid some of the problems associated with Christmas tree buying.'**

where you will display your tree. With this in mind, you will be able to tell what height tree you will need and whether all four sides of the tree must be suitable for display.

□ When you do go shopping for your tree, remember to select a tree that is already the right size for the space you have. Cutting large portions from the top or bottom of the tree will alter the natural beauty and taper of the tree.

□ Freshness is a very important factor in choosing the right tree. The fresher the tree is the better chance it has of lasting the whole holiday season. To determine freshness, run your fingers down a branch of the tree. The needles should be resilient but not brittle and should stay on the branch. In addition, you might want to shake or bounce the tree to make sure the needles are firmly attached.

□ Another consideration in choosing a Christmas tree is the type of tree. Pine, spruce and fir trees are commonly used as Christmas trees and are grown here in Michigan. The next few tips will help you distinguish

one type of tree from another. □ The Scotch Pine has needles that grow in clusters of two and, its dark, blue-green in color. The needles are usually 1.5 to 2.5 inches long. The Scotch Pine holds its needles longer than most other varieties of Christmas trees.

□ Eastern and Western White Pine trees are identified by their silvery, blue-green needles that are soft to the touch. Eastern White Pine needles are longer (2.5 to 5.0 inches) and more slender than the Western white Pine needles. Both trees grow their needles in clusters of five.

□ Spruce trees bear their sharp pointed needles singly along the twigs. The spruce generally does not hold its needles as long as pine trees do.

□ Fir trees also grow their needles singly along the twigs. They have short needles with rounded tips and usually retain their needles very well.

These guidelines should help you choose the tree that is right for your Christmas this year.

## MADD chapter slates candlelight vigil

FARMINGTON — The Oakland County chapter of Mothers Against Drunk Driving (MADD) will hold a candlelight vigil at the Nardin Park Methodist Church in Farmington Hills on Monday, Dec. 14.

Everyone is invited to attend the vigil which will begin at 7:30 p.m. The church is located on Eleven Mile, one block west of Middlebelt Road.

The purpose of the vigil is to provide a setting in which family and friends may remember their loved ones who have been killed by drunk drivers, according to Greg Bein, Oakland County MADD president.

The candlelight vigil also begins a period of hope for a less violent future for MADD which will sponsor other programs and projects during December to prevent drunk driving accidents during the holidays.

Among those projects is a "Red Ribbon Campaign" in which citizens are encouraged to tie a red ribbon to their left car door mirror or antenna as a sign to Oakland County that they hope for a safe holiday season and a stop to drunk driving.

For additional information or to have a name read during the recitation of people killed by drunk drivers during the vigil call MADD at 333-3060.

More information about membership in the Novi Trainers Running Club. More information about joining the group is available by calling the Novi Parks and Recreation Department at 349-1976 or President Leo Karvala at 349-7724.

The Trainers have changed the meeting place for their Wednesday evening runs. The group will meet outside the Northville High School gym every Wednesday at 6:45 p.m. until the time change in April. Club members recently participated in the Turkey Trot prior to the Thanksgiving Day parade in Detroit. The Trainers also will participate in the Novi's Eye Run on Belle Isle. Following the run, they will go to Xochimilco's for a Mexican dinner.

The club will hold its Christmas party on Dec. 19. "Tracker of the Year" ballots will be counted and the winner announced.

AGAPE SINGERS: The Agape Singers presented their "USO Can-

## CHURCH DIRECTORY

For information regarding rates for church listings call The Northville Record or Novi News 349-1700

ST. KENNETH CATHOLIC CHURCH 14951 Haggerty, South of Five Mile Road. Weekend Liturgies: Saturday 4:30 p.m., Sunday 8:00 a.m., 10:00 a.m., 12:00 noon. (June-September: 8:00 a.m., 9:30 a.m., 11:00) Church: 423-0288

NEW LIFE CHRISTIAN CENTER 57855 Grand River, New Hudson (1/2 mile west of Milford Rd.) Worship Services Sunday 11 a.m., Tuesday 7:30 a.m., Wednesday 7 p.m., Thursday Bible Study 7 p.m., For additional information: 349-7724

OPEN DOOR CHRISTIAN CHURCH 145 N. Center, Northville 349-2101 "We Invite You To Come And Fellowship With Us" Mark Frier, Pastor Services: Thurs. 7:30 p.m. Sun. 10 a.m.

GRACE CHAPEL William Tyndale College 12 Mile & Drake Roads Farmington Hills, 474-0151 8:45 a.m. Sunday School (all ages) 11:00 a.m. Worship 7:30 p.m. Wed. evening service Douglas L. Klein, Pastor Evangelical Presbyterian Church

FIRST PRESBYTERIAN CHURCH 205 E. Main St., Northville 349-9011 Worship: 8:30, 9:30, 11:00 Church School: 9:30-11:00 a.m. Nursery Available: 9:30-11:00 Dr. Lawrence Chamberlain - Pastor The Rev. James Pappas, Associate Pastor The Rev. Martin Aitkens, Associate Pastor

FIRST CHURCH OF THE NAZARENE 21260 Haggerty Rd., 348-7600 (1 1/2 miles S. of Milford) Sunday School 9:30 a.m., 11 a.m. Worship 9:30 & 11 a.m., Eve. 6 p.m. Bible Study Wed. 7 p.m. Dr. Richard Parrott, Pastor

EV. LUTHERAN CHURCH 303 Market St., 624-2483 Wed. 8:30 AM, Jr. & Sr. High Sunday School 9:45 a.m., 11:00 a.m. Morning Worship 10 a.m. Nursery Available At Services

ST. JOHN'S LUTHERAN CHURCH 22225 Gill Rd., Farmington Hills 474-0584 3 Miles S. of Gd. River, 3 Miles W. of Farmington Rd. Church 474-0584 Worship Service 8:30 a.m. & 11:00 a.m. 9:00 Education Hour (Nursery Available) Pastor Charles Fox

WALLED LAKE FIRST BAPTIST CHURCH 303 Market St., 624-2483 Wed. 8:30 AM, Jr. & Sr. High Sunday School 9:45 a.m., 11:00 a.m. Morning Worship 10 a.m. Nursery Available At Services

OUR LADY OF VICTORY 770 Thayer, Northville WEEKEND LITURGIES Thursday, 5:00 p.m. Sunday, 8:30, 11 a.m., & 12:30 p.m. Church 349-2821, School 349-2810 Religious Education 349-2559

FIRST APOSTOLIC LUTHERAN CHURCH 26255 Hales Road at 11 Mile Farmington Hills, Michigan Services every Sunday 9:45 A.M. Also, First and Third Sunday 11:00 P.M. Sunday School 10:15 A.M. Bible Class - Tuesday, 7:45 P.M. Song Services - Last Sunday of month - 7:00 P.M.

ST. PAUL'S LUTHERAN MISSOURI SYNOD 5314 E. Six Streets, Northville L. Luback, Pastor C. Grogan, Relief Asst. Church 349-3140 School 349-3146 Sunday Worship, 8:30 a.m. & 11:00 a.m. Sunday School & Bible Classes 10:00 a.m., Saturday Vespers, 6:00 p.m.

HOPE LUTHERAN CHURCH 12 Mile East of Haggerty Farmington Hills Sunday School 8:30-9:45 Sunday Worship 9:30-10:30 V.H. Meserbrink, Pastor Phone: 553-7170

FIRST UNITED METHODIST CHURCH OF NORTHVILLE 249-1144 8 Mile & Ten Mile Rev. Eric Hamman, Minister Rev. Richard S. Keane, Pastor Worship Services: 9:30 & 11 a.m., Wed., 7:30 a.m. Adult Bible Study: 10:30 a.m. Nursery thru 3rd Grade, Sr. High 11 a.m.

GO TO CHURCH SUNDAY! NOVI UNITED METHODIST CHURCH 41671 W. Ten Mile-Meadowbrook 349-2522 (24 hrs.) Sunday Worship at 10:30 a.m. Church School 9:15 a.m. Nursery Care Available Charles R. Jacobs, Kearney Kirkby, Pastors

ORCHARD HILLS BAPTIST CHURCH 23455 Novi Rd., (between 9-10 Mile) Bible Study For All Ages 9:45 a.m. Worship Services: 9:30 a.m., 8 p.m., Wed., Mid-Week Prayer Serv., 7 p.m. 349-5665 Kenneth Stevens, Pastor

CHURCH OF THE HOLY CROSS EPISCOPAL 10 Mile between Taft & Beck, Novi Phone 349-1175 8 a.m. Holy Eucharist 9:45 Christian Education 10:15 Holy Eucharist The Rev. Leslie F. Harding

WARD EVANGELICAL PRESBYTERIAN CHURCH at 17030 Farmington Road Livonia, MI 48154 (313) 422-1150 Sunday Worship and Sunday School 8:30, 10:00, 11:30 a.m., and 7:30 p.m. at Schoolcraft College, 349-3440 Sunday School: 10:00 a.m.

SAINT JOHN'S EPISCOPAL CHURCH 574 South Shelton Road, Plymouth 48150 423-0191 Holy Eucharist: Sunday 7:45 A.M. and 10:00 A.M. Wednesday 10:00 A.M. Sunday School: 9:00 A.M. Bible Study: Sunday 9:00 A.M. Wednesday 7:00 P.M. Holy Eucharist: Sunday 16:00 A.M. Sunday Morning Nursery Care Available

Casteline Funeral Home, Inc. A Community Business Since 1937. The Casteline Family has been serving The Northville, Novi, and the Surrounding Area For over 50 Years. Funeral planning on premises, cremation services available, assisting families with benefits, domestic & foreign shipping & receiving. 122 West Dunlap Street, Northville, MI 48157 (313) 349-0811 RAY J. CASTELINE 1982-1989 FRED A. CASTELINE - RAY J. CASTELINE II

TWO WAYS TO SEND JOY TO THE WORLD Send the FTD® Fireside Basket Bouquet. Or the FTD Holiday Basket Bouquet. DAILY DELIVERIES TO FRIENDS & FAMILY IN DETROIT AND SUBURBS. Step In For A Beautiful FREE Calendar & Gift Book. Creative Flowers For All Occasions Northville Gallery of Flowers 135 E. Cady St., Northville 349-3811

Still time to... DECK the WALLS... with In Stock Wallpaper 20% to 50% OFF ALL STOCK PATTERNS VISIT OUR NEW STORE 5826 SHELDON ROAD CANTON Beautiful Selection of Country and Traditional Borders Ready to Hang Today Beautiful Selection of Window Treatments Introducing JOANNA Grober Custom Shades 25% to 40% off In Stock WALLPAPER, INC. OPEN 7 DAYS MON-FRI, 10-9; SAT, 9-6; SUN, 11-4

Select from the FRESHEST trees in town! Fraser Fir Douglas Fir Scotch Pine Spruce. Wreaths Roping Grave Blankets Poinsettias. No matter the weather, in rain, sleet or snow, our trees INSIDE are ready to go. Raney's Rainbow Gardens 10 Mile and Milford Rd. South Lyon 437-2856 Open 9 a.m. Fri. & Sat.

FRIDAY, DEC. 11 GET READY FOR SOME HEAVY-DUTY POWER SHOPPING. 1 DAY SALE. FOR WOMEN: 30% off all regular-priced Russ Togs. Tan Jay coordinates. Career, Moderate Coordinates. Reg. \$38-85, 26.00-59.00. 25% off all dresses. Barter, Career, Moderate, Petite, Junior, Women's Dresses. Reg. \$30-420, 22.50-1180. 30% off all updated blouses, pants and skirts. Many famous makers. Handfiers. 30% off entire stock of blouses in Misses' Blouses, Petite, Women's Sportswear. Reg. 19.99-630, \$14-26.60. 30% off all regular-priced sweaters in Misses' Sweaters and Women's Sportswear. Liz Claiborne and Traditional Collections not included. Reg. \$20-650, \$14-435. 30% off all petite sweaters. Includes sweaters already reduced. Petite Sportswear. 30% off all activewear jackets. London Fog, Gallery, more. Includes jackets already reduced. Misses', Junior, Women's, All-Weather Coats. ACCESSORIES: 25% off entire stock handbags. Leathers, vinyls, more. Coach bags not included. 30% off all ladies' gloves. Isotoner included. Gloves. Reg. \$8-444, 5.00-30.80. 25% off entire stock of small leather goods. Wallets, key rings, more. Personal Computer not included. Small Leather Goods. 25% off entire stock of fashion jewelry. Monet, Trilari, Marvelle, more. Fashion Jewelry. Reg. 3.99-\$100, 2.99-975. 30% off all regular-priced daywear and panties. Slips, panticones, camisoles and tap pants. Daywear and Panties. FOR MEN: 30% off all leisurewear and robes. Loungewear. Reg. \$15-130, 10.50-99.1. 30% off all Crowley's Own hosiery. Stockings, pantyhose, more. Reg. 1.50-99, 1.05-6.30. 30% off entire stock of ladies' slippers. Isotoner, more. Casual Footwear. Reg. 5.99-930, 4.20-821. 30% off all sleepwear. Barbizon, Miss Elaine, Lorraine, more. Reg. \$12-942, 8.40-28.99. FOR KIDS: 30% off entire stock of boots for men & women! 25% off entire stock of Hush Puppies for men & women. Daniel Green, Evans, more. 25% off all slippers for men & women. Daniel Green, Evans, more. 25% off all 9-West shoes, boots. 25% off entire stock of men's Nun Bush shoes. Women's shoes, all stores. Men's Shoes available at Westborn, Macomb, Livonia, Lakeside and Universal. HOME: 25% off all Christmas Trim-a-tree, wrap, more. In Gifts. 25% off all open stock Farberware. Not including 12 pc. Farberware set. In Housewares. 20% off all collectibles. In Gifts. 30% off all regular-price accent pillows, chair pads and rocker seats. In Accent Pillows. Gifts & Housewares at Westborn, Macomb, Livonia, Birmingham, Farmington, Lakeside, Universal. Accent Pillows at Westborn, Macomb, Livonia, Lakeside and Universal.

# Chocolate's enjoyed world-wide

Continued from 1

The Spanish added water and cane sugar and heated the brown brew.

Don Theobroma was the favored drink of Spain's nobility. Cortes' money plantations gave Spain a virtual monopoly on the chocolate market for nearly a century, but its aromatic reputation soon drifted across Europe.

factory was established in the Massachusetts Bay Colony in 1765.

By 1828, Dutch chemist Conrad van Houten, developed a process for extracting some of the cacao bean's fat — a substance to be called cocoa butter. Two decades later the process was refined, blending cocoa butter and sugar with ground beans, and the chocolate candy bar was born.

Soon the Swiss would develop a mashing to stir or concoct, liquid chocolate to enhance the creamy smoothness we know and crave.

During the manufacturing process, chocolate is broken into nibs or large chunks, and is pulverized between heavy disks where heat and grinding pressure produce a thick, dark paste called chocolate liquor, though it has no alcoholic content.

When broken down into its basic components, chocolate may be used in a variety of ways. Hardened chocolate liquor becomes baking chocolate. When subjected to high pressure, cocoa butter can be extracted, and a residual powdery substance makes our hot chocolate mix.

If extra fatty cocoa butter is blended in with the chocolate liquor, the mixture becomes a candy bar. Finally, if cocoa butter is used without chocolate liquor in the production process, white chocolate is the end product.

Manufacturers may substitute other ingredients, like vegetable oil, for cocoa butter. Such a concoction

cannot legally be called chocolate. Confectionery coating and chocolate flavored are two common names for the simulated stuff.

Chocolate factories range from the expansive Nestle plant in the Swiss Alps to perhaps a single-room in a Manhattan office building complex. Recipes and methods differ, but one common thread in the chocolate-producing industry is the same — automation.

Candy bars we buy from the shelves of supermarkets may be virtually untouched by human hands in the production process. Conching machines stir a lake of chocolate liquid. Hershey plants conch chocolate for 72 hours, for example.

The contraptions spew out enough Theobroma for an individual bar into mold, shuttle it into a cooling tunnel, flip it out onto a conveyor belt, then wrap each confection and send it to the shipping storeroom.

Mesoamerican royalty in the 12th century are said to have partaken in rituals of drinking *xocolatl* in marriage rites. Mexicans today still toast happiness with the sweetened version of chocolate *cahuate*.

Theobroma met with mixed reaction throughout its history. Some people swooned while others scorned it. Like the Aztecs, many Europeans considered chocolate to have medicinal powers to calm fevers, cure chronic indigestion and prolong life. One British doctor, however, disputed chocolate's therapeutic claims and pronounced it a poison — because it simply tasted too good to be a medicine.

Many touted Theobroma as an aphrodisiac, enhancing romantic moods and inclinations. They may not have been too far off in their assessments. Modern analysis of chocolate indicates small concentrations of phenylethylamine, a chemical naturally produced in the brain, that some speculate increases when people fall in love.

Today, sweet-toothed Swiss lead the world in chocolate consumption, averaging 22 pounds per year. Consumption is on the rise in the United States, pegged at between two to 10 pounds. The U.S. leads in cacao bean imports and chocolate production, while nearly 45 percent of the world's cacao beans are grown in the Bahia state in Brazil.

The Godiva Chocolate Company in Brussels, Belgium, airfreights chocolates all across the globe. In Japan, chocolate connoisseurs pay almost \$40 per pound. Godiva and other European company chocolates contain alcohol other than in small extracts cannot be imported to the U.S.

From the affluent chocolate to the economy chunky, store shelves, speciality shops and mail-order delicacies stock the sweet terrain guaranteed to cure any craving.

Theobroma lovers can also subscribe to their very own magazine, "Chocolate News," a Manhattan-based publication printed in chocolate-covered and chocolate-scented ink.

(Source: *Chocolate: Food of the Gods*, "National Geographic," Nov. 1984)

# Engagements

**Mr. and Mrs. Stephen Rebin of Springfield Drive in Northville announce the engagement of their daughter, Laura Ann, to Sgt. Craig W. Clary, son of Mr. and Mrs. Kenneth Clary of East Glenhaven Circle in Novi.**

The bride-elect is a 1986 graduate of Northville High School and is a business student at the University of Michigan-Dearborn.

The groom-elect is a 1984 graduate of Novi High School and now is serving in the United States Army. He currently is assigned to the White House Communications Agency.

The wedding will take place in June 1988.



LAURA REBIN and SGT. CRAIG CLARY

# Births

ANDREA JOY SCHMID

Ken and Nancy Schmid of Hollydale in Novi announce the birth of their first child, a daughter.

Andrea Joy Schmid was born Nov. 17 at St. Joseph Hospital in Pontiac, weighing seven pounds, six ounces.

Maternal grandparents are Bill and Dorris Compton; paternal grandparents are Bob and Kay Schmid. The new arrival's great grandparents are Elsie Wacholz and Ruth Schmid.

# People

Three Novi residents — JAMES CLANCY, PATRICK HARAN and LISA LUDINGTON — are seniors at Alma College. Alma College and Hanover (Indiana) College were ranked the three best liberal arts colleges in their region by presidents of colleges in Midwestern and Western states, according to the results of a U.S. News & World Report survey published in the magazine's Oct. 26, 1987, edition.

The ranking is for a region that includes the 23 states lying west of the Alleghenies and north of the Mason-Dixon line. Ranked first and second in the region were Alverno (Wisconsin) College and Wittenberg (Ohio) University.

Alma, one of 50 liberal arts colleges nationally producing the highest proportion of U.S. scientists and medical professionals, was first in the U.S. News rating of science programs among the 184 liberal arts colleges in the West and Midwest.

JULIANE BORG of Novi was cast in the role of Nellie Ewell in Western Michigan University's production of the Tennessee Williams play, "Summer and Smoke."

# Sleuth tracks down the world's top chocolates

Continued from 1

know, the best of everything. The wine, the caviar, the food — that's all taken care of. But we want to put out the best chocolates, too, and I don't know where to start.

"That's where you come in," she smiled. "I want you to find the best chocolates for me... something that will really impress the guests... something that will let them know they're dealing with people of taste and refinement."

"Listen, sugar," I said. "You sure you don't have a missing person you want me to chase down for you? Wandering husbands, I do. Missing persons, I do. Chocolates, I don't do."

"Besides, I can save you a lot of time and money... my time doesn't come cheap you know. Just go out and get some Godiva chocolates. That should impress all your yuppie friends."

"No, no, no," she sighed. "You're not getting the picture. I know all about Godiva chocolates. Everybody knows about Godiva chocolates. That's the problem. You can get Godiva chocolates at the mall. I need something special. Something you can't get at the mall. Something that will just blow everybody away in terms of taste and refinement and prestige."

And then she said the key words.

"Money's no problem. I'll double your standard rate. Just get me the best chocolates."

I still didn't understand why she couldn't have done it herself. Maybe I was to be part of the so-called prestige. Maybe part of the yuppie appeal was going to be telling her friends she had hired a private eye to find her chocolates for her.

But that was her problem, not mine. Besides, anybody who wants to double the going rate for a piece of my time isn't going to get much of an argument.

Besides, I hate to see a lady in distress, so I took the case.

One of the little tricks to private eye work is simple. I don't want to reveal trade secrets, but it's amazing how often the local library and a telephone book can come in handy.

I left the gun inside the desk drawer on this one and headed for the library to bone up on chocolates.

My search took me all around the Metro Detroit area.

But like it is more often than you might expect, the best information was close to home. At MacKinnon's restaurant in downtown Northville

less than a block from my office. Tom MacKinnon is a young, cheerful type with a little beard and a big smile. He's also a confessed chocoholic.

He was wearing a tux when I arrived just before 10 o'clock that night. And he was ready for me — a big stack of books and magazines spread out on the bar in front of him.

He started explaining the history of chocolate, how chocolate is made. All the technical stuff.

He gave me a book called "The Ultimate Chocolate Cake Book" by Pamela Asquith which contained some good hard information.

Pamela gave me some good stuff. "Fine European products often list the amounts of cocoa solids and sugar on the package," she said. "Of course, the higher the amount of cocoa solids, and the more it is conched (kneaded by machine for up to several days), the better the product."

"For instance, a Swiss brand, Lindt Extra-Bittersweet, contains at least 59 percent cocoa solids. In the United States, the minimum amount of cocoa solids required for a chocolate to be termed 'bittersweet' is 35 percent. If you assume that most manufacturers comply only with the minimum requirements, it is obvious why fine-quality chocolate often costs more. Cocoa solids are more

expensive than sugar, and conching is an expensive, time-consuming process.

Pamela went on to say she has used many fine brands of chocolate, just the taste and texture he's looking for."

"Chocolates have changed over the last five-ten years," he continued. "There's much more awareness of quality about fine chocolates... something that has to be eaten in a month or you can kiss it goodbye. Not this stuff which has a shelf-life of several years."

"Keep going," I told him. "Give me some brand names. Like Godiva or Cadbury, but something which is exquisite and nobody's ever heard of before. Not even yuppies."

"There's a place right here in Michigan called Gayle's Chocolates which makes awfully good chocolates," he said. "But if you really want the best, you're going to have to go to Europe."

"Belgium and France are the best places for chocolates," he continued. "There's Linoire in Paris which makes excellent chocolates, but I'm rather biased toward Wittamer chocolates in Belgium because I used to work there."

"Neither one of those companies is real big... but that's because they're the best. When you get too big, you sacrifice quality. They know that."

"If your yuppie client really wants to impress her yuppie friends, here's what to do. Tell her to call Wittamer over in Brussels and tell her not to forget there's a five-six hour time difference."

"It's going to help if she can speak French, but if she can't, here's what she has to do. When somebody answers the phone, just say, 'Chez Louise, s'il vous plait.' When he gets on the phone, tell her she's got to talk slow. He knows English, but it helps if you don't rattle it off."

"Tell him what you want, and they'll ship it by air freight. You can get it within a couple of days."

"You're going to pay for it, but I get the impression that's part of the allure. Chocolates imported from Wittamer's in Belgium. That's class. And you're getting the best."

MacKinnon smiled now. "You take a piece of their chocolates, set it on your tongue and let it just sort of melt slowly in your mouth," he said. "It's great. Particularly if you enjoy the best."

MacKinnon had been very helpful. I stuck my notebook back in my pocket and headed out into the cold winter night. "Old dog-legs is going to like this," I thought. "It will make all her yuppie friends sit up and take notice."

"Then, again, you never know about yuppies."

# Weigh your options with health clubs

Do some check-ups before you start the sit-ups.

You don't want to be hurt financially or physically when you join a health club, according to Elaine Glasser, Extension Home Economist for the Oakland County Cooperative Extension Service.

The hype in many promotions makes it difficult to tell if you're joining a reputable club. There are no federal regulations of health spas, and few states protect consumers. You have to protect yourself.

Size does not indicate stability. Both big and lit-

tle clubs go out of business. Ask how long the company has been in business.

Glasser recommends looking for a cancellation clause — a cooling-off period, even if it is short — that lets you change your mind if you sign a contract. Choose a short-term contract first to make sure you are satisfied with the facilities and instruction.

After judging stability, investigate service. Make sure promised equipment is available. Know what your options are if the club changes

facilities, location or focus of instruction. Will you get a pro-rated refund if the club moves to an inconvenient location?

Then, before you commit yourself, find out if instructors are fit to teach fitness. Ask about staff training. Find out, at a minimum, if the staff is certified by the American College of Sports Medicine (ACSM) or has degrees in exercise physiology. Find out if the staff is trained in injury prevention and intervention. Talk to other club members about their experiences with instructors, and ask if staff turnover is high.

Weigh your options before you lift any weights.

## TOYS 'R' US

**OPEN 'TIL MIDNIGHT**

### Toys To Top Every List!

**Nikko RADIO CONTROL THUNDERBOLT**  
Hot frame buggy with front and rear friction damper shocks!  
Ages 8-up

**11999**

**Tyco SUPER TURBO TRAIN**  
Ages 8-up  
Mail-In Rebate

**4499**

**Tomy GHOST RACER ROAD RACE**  
Ages 8-up  
Our Price: 54.99  
Mail-In Rebate: 5.00

**4999**

**Tyco RADIO CONTROL SUPER TURBO HOPPER**  
Rechargeable batteries included! 4-wheel drive, ready to run! Full function.  
Ages 7-up

**12999**

**Shyster RADIO CONTROL '57 CHEVY**  
2 channel, 7 function transmitter, realistic engine sound.  
Ages 8-up  
Mail-In Rebate

**9999**

**Nikko RADIO CONTROL DICTATOR**  
Commands the road with twin motors, 4-wheel drive, spiked tires.  
Ages 8-up  
(2 1/2" tall axle tires not included)

**17999**

**New Bright RADIO CONTROL CORVETTE**  
Authentic styling! Full steering action.  
Ages 8-up  
(Four C batteries not included)

**1697**

**Tyco TURBO TRAIN ELECTRIC H.O. SET**  
World's fastest train 3-car set with new 40-3 track.  
Ages 8-up

**4199**

**Galoot MICRO MACHINES**  
Unique sets of mini cars, boats and planes with decorative Ages 4-up

**399**

**Shyster RADIO CONTROL CHEETAH**  
Aerodynamic design. Spiked tires, pistol transmitter.  
Ages 8-up  
(2 1/2" tall axle tires not included)

**9999**

**Life-Like TOYS "R" US H.O. TRAIN SET**  
4-unit set with 3 circular track and power pack!  
Ages 8-up

**1997**

**There's a TOYS 'R' US near you!**

• ANN ARBOR (In Arborland Mall)

• DEARBORN (Next to Dearborn Theatre)

• LIVERMORE (Next to Summit Place Mall)

• MADISON HEIGHTS (South of Oakland Mall)

• NOVI (Just west of 12 Oaks Mall)

• PONTIAC (Across from Summit Place Mall)

• ROSELAND (Across from Macomb Mall)

• SOUTHFIELD (South of 161-12 Mall)

• SOUTHGATE (Corner of Trenton Ave.)

• STERLING HEIGHTS (Next to Lakeside Mall)

• WESTLAND (At Wayne and Warren)

• 8 MILE ROAD (Between Van Dyke & Groesbeck)

**MONDAY - SATURDAY 8:00 AM - MIDNIGHT; SUNDAY 9:00 AM - 10:00 PM**

**CHARGE IT!**  
VISA • MASTERCARD  
AMERICAN EXPRESS  
DISCOVER

### HYPNOSIS WORKS

We Offer Help With

- Weight Control
- Fears/Phobias
- Better Health
- Stress Management
- Stop Smoking
- Study Skills
- Pain Management
- And Much More...

Call Today

**ADVANCED CREATIVE THERAPY**  
428 N. Central, Northville  
344-4774

### The last thing you need now is a problem with our condominium insurance.

At a condominium life! A home of your own... without maintenance of your own.

But like a home, you do have personal property and liability insurance needs... and some building insurance needs. You also have some special insurance needs for your condominium.

The Condominium Unit-Owners optional loss assessment coverage from Auto-Owners covers some losses that may not be provided for through your condominium association. So it complements your protection.

The condominium unit owners optional additions and alterations coverage provides for your building when not covered by your association policy.

Just ask your "no problem" Auto-Owners agent about Condominium insurance for you. You may enjoy your condo paradise a little more assuredly.

**C. Harold Bloom Agency**  
108 W. Main  
Northville, MI  
349-1252

# Holiday lighting's beautiful but follow safety measures

Since Rudolph the Red-Nosed Reindeer won't shine on your home long enough to create that festive holiday glow, you'll probably depend on electric lighting to do the job.

Decorative lighting — when used correctly — is a safe and inexpensive option, according to a Detroit Edison lighting expert.

John Bradley, Detroit Edison's residential lighting specialist, advises holiday decorators to examine every light string carefully for chipped or damaged sockets or frayed wires.

"These items should be thrown out," she said. "Also, throw out any lights that do not have the Underwriters Laboratories (UL) seal. The seal indicates the lights meet specific safety standards."

Bradley said holiday lighting can be penny-wise as well as safety-wise. "Most strings of lights have an operating cost of between a half-cent and five cents per string for four hours of use," she said. "Tinkie-type lights use even less electricity because they are off half the time."

Bradley offers the following safety suggestions for indoor lighting:

- Use no more than three sets of standard lights on each indoor extension cord.
- Never use lights on a metal tree. Instead, a lighted

revolving color wheel or low-wattage colored floodlights may be used to illuminate the tree.

□ Keep lights away from carpeting, furniture, curtains and drapes. Some standard lights produce enough heat to scorch or damage items they contact.

□ Use only flame-resistant ornaments and other decorations, including artificial snow, on and around the tree.

□ Don't put the tree near an active fireplace.

□ In terms of outdoor lighting, Bradley offers these suggestions:

□ Use only weather-resistant equipment and lights manufactured for outdoor use.

□ Use only outdoor extension cords with molded plugs and sockets. Keep cords out of the way to prevent tripping accidents.

□ Keep all electrical connections off the ground and hang sockets downward to prevent water from seeping into them.

□ Fasten extension cords or light sets to wood or hardboard surface with insulated staples; never use nails or tacks because they may pierce the wires and cause shock or shorts.

□ Don't run outdoor lighting cords through door or window openings where they can be damaged.

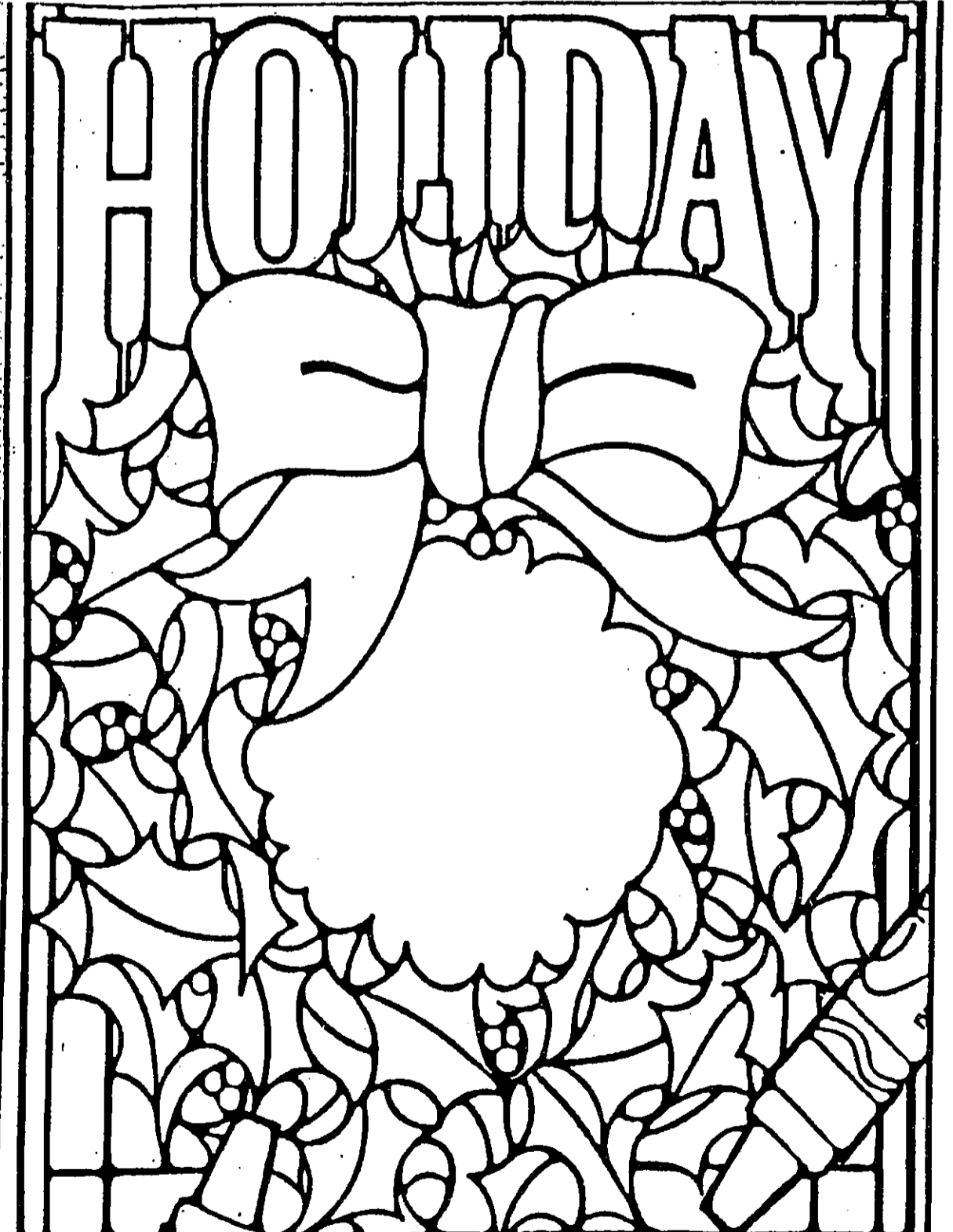

Kids! — Come join in the fun! Enter our Crumpets Color Contest! Every entry will receive a FREE TREAT just for entering! Our deadline is Dec. 18. You could win a giant Christmas Basket filled with treats and surprises. Just bring your entry to CRUMPETS BAKE SHOPPE!

P.S. Mom, you will enjoy seeing our wonderful baked goods including Cookies, Dessert Trays, Round Party Leaves for dips, Stocking Stuffers, Tins for Filling and so much more!

### Crumpets Bake Shoppe

48053 W. Seven Mile Road, Highland Lakes Shopping Plaza 348-7830

### Owned By The Members We Serve

#### Membership Eligibility

**SCHOOL SYSTEMS**

- Farmington
- Clarenceville
- Novi
- South Lyon
- Howell
- Pinckney
- Fowlerville
- Livingston
- Brighton
- Oakland Community College

**ELECTED OFFICIALS AND EMPLOYEES OF THE CITIES OF:**

- Farmington
- Farmington Hills
- Novi

**OTHER EMPLOYMENT GROUPS**

- U.S. Post Office — Farmington
- Bradart Products Inc.
- Farmington Farmington Hills Chamber of Commerce Members
- Novi Chamber of Commerce Members

Any person related to a member by blood, marriage or adoption may join, too.

**Livingston-Oakland Counties Federal Credit Union**

Regular Office Hours  
9:00 A.M. to 5:00 P.M. Monday-Thursday  
9:00 A.M. to 5:00 P.M. Friday

**NCUA**

**Great Loan Values**  
**No-Fee Credit Union Checking**  
**Regular Share Savings**  
**IRAs**  
**Money Market Accounts**  
**Automated Teller Machines (Statewide access)**  
**Payroll Deduction**  
**Once-A-Member, Always-A-Member**

**Farmington Office**  
23617 Liberty Street  
Farmington, MI 48024  
(313) 474-2200

**Howell Office**  
115 University Drive  
Howell, MI 48823  
(517) 546-8390

### Discover the Michigan Advantage

# Working Adults

The University of Michigan-Dearborn Evening Studies Program

Give yourself an educational advantage with the Michigan tradition of excellence and high standards. Undergraduate degree programs can now be completed in the evening on a part-time basis at The University of Michigan-Dearborn. Let us help you expand your career opportunities, enhance your life goals, and earn a degree.

Apply now for the winter term which begins **January 6, 1988**.

For information regarding specific programs, call the Evening Studies Program office at (313) 593-5120 or mail the attached coupon to:

The University of Michigan-Dearborn  
Evening Studies Program  
137 Classroom-Administration Building  
Dearborn, Michigan 48128-1491

The University of Michigan-Dearborn is an affirmative action/non-discriminatory institution.

### The University of Michigan-Dearborn Evening Studies Program

**My field of study is likely to be:**

□ Art History

□ English

□ Psychology

□ Bachelor of General Studies

□ History

□ Sociology

□ Economics

□ Liberal Studies

□ Training Design and Development

□ Education

□ Political Science

Name \_\_\_\_\_ Phone \_\_\_\_\_  
Last First

Address \_\_\_\_\_ City State Zip \_\_\_\_\_

# Diet-tempting recipes for lovers of chocolate

**Abhhhh...chocolate!** The word alone inspires yearnings. These luscious recipes enhance this most revered of foods with ingredients that only make it better...whipping cream, butter, cream and more. Each kitchen-tested recipe provides thorough directions to ensure success. From muffins to truffles, the tantalizing recipes will strengthen your devotion to chocolate—the ultimate indulgence. So, stock up! Store chocolate in a cool, dry place until needed. Or, wrap it, lightly and store it in the refrigerator. It will be at its freshest for cooking or eating as is.

**Creamy Chocolate-Peanut Butter Pie**  
One package (three and one-half ounces) chocolate pudding and pie filling  
One and one-half cups milk  
One prepared chocolate flavored crumb crust  
One cup whipping cream, divided  
Two tablespoons creamy peanut butter  
One tablespoon confectioners sugar  
One-half teaspoon vanilla extract  
Whole peanuts

## Chocolate Bread Pudding

Four cups one-inch French bread cubes, crusts removed, (six to seven slices)  
One cup firmly packed brown sugar  
One teaspoon vanilla extract  
Whipped cream

Place bread cubes and nuts in buttered one and one-half quart casserole. Heat milk and chocolate in small saucepan until chocolate is melted. Beat with hand mixer until chocolate is completely dissolved. Meanwhile, beat eggs and sugar until well blended. Stir in chocolate mixture and vanilla. Pour over bread and nuts. Let stand, covered, at room temperature 30 minutes. Preheat oven to 325 degrees F. Bake, uncovered, 30 to 35 minutes, or until knife inserted near center comes out clean. Cool at least one hour on wire rack. Serve topped with whipped cream.  
Yield—six to eight servings

## Chocolate Nut Crescents

One cup (two sticks) butter  
One cup sifted confectioners sugar  
Three-quarter teaspoon almond extract  
One and three-quarter cups all-purpose flour  
One-quarter cup unsweetened cocoa  
One-quarter teaspoon salt  
One-half cup finely chopped almonds  
Confectioners sugar

## Double Chocolate Nut Muffins

One-quarter (one-half stick) butter  
Two-thirds cup sugar  
Two eggs  
One and one-third cups all-purpose flour  
Three tablespoons unsweetened cocoa powder  
One teaspoon baking powder  
One-quarter teaspoon salt  
One container (eight ounces) vanilla yogurt  
One-half cup EACH: miniature semi-sweet chocolate pieces, chopped nuts

Prepare pudding according to package directions, using one and one-half cups milk. Cool slightly; pour into crust. Refrigerate one to two hours, or until pudding has become firm. Combine one-half cup whipping cream, peanut butter, sugar and vanilla in small mixer bowl. Whip until stiff. Spread over chocolate layer. Refrigerate at least two hours. Just before serving, whip remaining whipping cream. Pipe through pastry tube fitted with fluted tip around outer edges of pie. Garnish with whole peanuts.  
Yield—One eight-inch pie.

## Spirited Truffles

Five ounces milk chocolate, broken into pieces  
Four ounces sweet baking chocolate, broken into pieces  
One ounce unsweetened chocolate, broken into pieces  
Three-quarter cup whipping cream  
Three to four teaspoons raspberry liqueur  
Six ounces sweet baking chocolate  
One tablespoon vegetable oil  
Unsweetened cocoa

Place first three chocolates in work bowl of food processor or blender; finely chop chocolate. Heat cream to just the simmering point. With machine running, gradually add the cream, mixing until the chocolate is melted. Scrape down sides of container to make sure all of chocolate is melted. Blend in liqueur. Cover a cookie sheet with waxed paper; butter paper. Spoon chocolate mixture in a thin layer onto cookie sheet. Refrigerate until chocolate is firm, about 30 minutes. Return to work bowl or blender. Process until light and fluffy, about 30 seconds. Spread on cookie sheet again and refrigerate until chocolate can be formed into balls but is not hard, about 20 minutes. Carefully shape into one-inch balls. Freeze until firm. Melt six ounces sweet baking chocolate and oil in small heavy saucepan over low heat. Dip frozen chocolate balls into melted chocolate mixture to coat. Place on waxed paper lined baking sheet. Sprinkle lightly with cocoa. Keep frozen until ready to serve.  
\*Almond, peppermint or orange liqueur may be substituted for raspberry.  
Yield—approximately five dozen

Preheat oven to 350 degrees F.



Home-made chocolates can be beautiful as well as mouth-watering

## Chocolate Caramels

One cup (two sticks) butter  
Three ounces unsweetened chocolate  
Two and one-quarter cups sugar  
One can (14 ounces) sweetened condensed milk  
Three-quarter cup light corn syrup  
One-half cup coarsely chopped nuts

## Chocolate Caramels

Melt butter and chocolate in three-quarter heavy saucepan over low heat. Stir in sugar, condensed milk and corn syrup until well combined. Cook over medium heat, stirring frequently, to firm ball stage or 240 degrees F., 15 to 18 minutes. Remove from heat. Stir in nuts and vanilla. Pour into well-buttered nine-inch square pan. When candy is firm, cut into one-inch squares. Wrap in plastic wrap. Store in cool place.  
Yield—Two and one-half pounds candy.

# Diversions

theNOVI NEWS 7C THURSDAY December 10, 1987

## Resort weekends are not far away

Travel industry statistics show that we're taking more vacations, but they're shorter, often just weekend getaways.

Part of the reason, the travel experts say, is that many couples are both working and have difficulty finding time to take long vacations together.

Armed with that information, hotel/motel owners are offering enticing weekend breakaways. Many have themes—they may be tennis weekends, cross-country ski packages or New Year's Eve galas.

Because winter weather can be a discouraging factor if much travel is involved, area teachers and business people relate that they seek out locations which are no more than three hours distance from home.

Here are two we've tried that are accessible from the I-75 expressway

and can be reached within three hours of quitting time on Friday night.

For those who have thought the eastern side of the state along Lake Huron is relatively bare of luxury hotels, it's not true. There's a superior Holiday Inn right on the bay at East Tawas—travelers take the I-75 exit at Standish and continue north on the 53 along the lake. From the Northville/Novi area the trip takes three hours.

In addition to giving a panoramic view of the bay, the resort is within walking distance of the City of East Tawas and the harbour (where joggers and walkers have ample space to exercise along the docks). The resort boasts a Jacuzzi and sauna, sunbathing facilities, satellite television and Showtime movies.

From now through May 1, there is

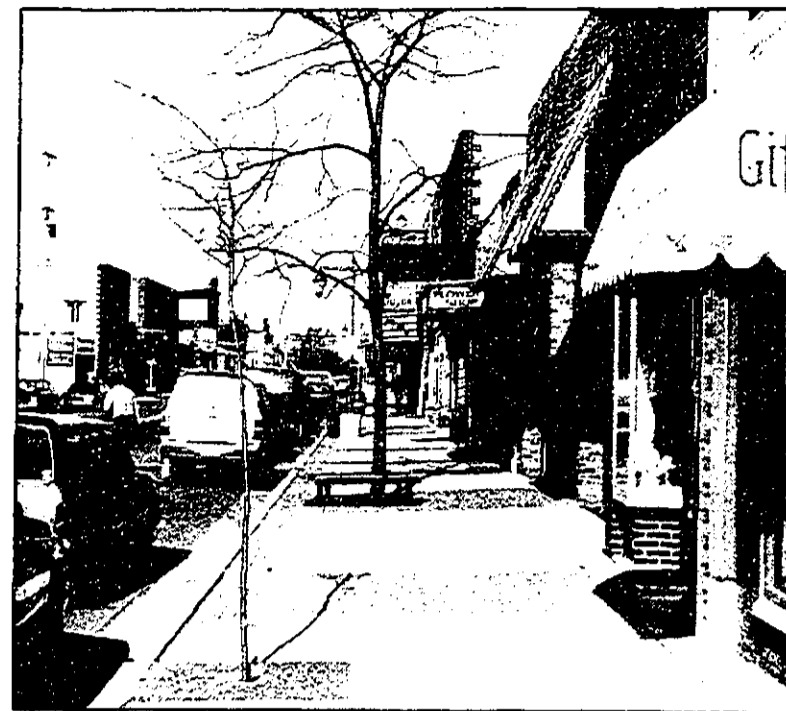

East Tawas' downtown exudes a certain charm

a "Couple Capers" offering a king leisure room, breakfast for two

chocolates and bubble bath and a welcome of chilled champagne for \$76.95 a couple.

A winter cross-country ski package for two nights includes two breakfasts, one dinner, moonlight guided ski tour of Corsair (transportation included) followed by a poolside wine and cheese party.

Corsair ski area is eight miles away in the Huron National Forest and has more than 41 miles of groomed and marked trails. This package is \$85.95 a person for the weekend.

Reservations are needed and may be made by calling (517) 992-8601.

Bay Valley Hotel and Resort on I-75 exit 160 between Saginaw and Bay City is even closer to home. In fact, it can be reached within two hours.

It offers a variety of "summer in the winter breakaways," including a tennis weekend with three hours of reserved court time, a night's stay, complimentary drink and use of the swimming pool, sauna, steam,

whirlpool and exercise room. For two, it's \$85 a night.

If you're looking for a special New Year's Eve celebration Bay Valley offers a deluxe room for two, dinner, entertainment and dancing plus use of its facilities and brunch New Year's day for \$190 for two.

Bay Valley also has a slightly different "Holiday Hot Spot '88" offering for Easter, Memorial Day, Independence Day and Labor Day next year. A three-night stay with breakfast and dinner allowances including use of facilities for three nights is \$110 a person.

Reservations are a must and may be made toll free in Michigan by calling 1-800-292-5025.

Both Tawas Bay Holiday Inn and Bay Valley are located north of another diversion—Manufacturers' Marketplace at Birch Run exit of the I-75 now has 45 manufacturers' stores and is a mecca for bargain shoppers. Open seven days a week, it's a popular stop to "break up the trip."

—Jean Day



The Lake Huron shoreline

## College offers 'Cuckoo's Nest' Nearby

Henry Ford Community College's Performing Arts Center will present *One Flew Over the Cuckoo's Nest* at the Astry Auditorium on the HFCC Campus Dec. 10, 11 and 12 at 8 p.m. The production is based on the Dale Wasserman interpretation of the Ken Kesey novel about society's definition of insanity in the 1960s.

As part of their preparation for their roles, cast members visited the Northville Regional Psychiatric Hospital and talked to staff members Carol Park and L.L. Mackenzie about mental illness.

The production is an associate entry in the American College Theater Festival. Admission is \$4 (\$3 for students). For more information call 945-9634.

**Victorian Christmas:** The Plymouth Historical Museum's showing "A Very Victorian Christmas"—a special presentation with a variety of related exhibits—through Jan. 15.

The museum's halls are decked in greens, the trees are decorated in themes ranging from patriotic to antique die-cuts, and the men and women are dressed in holiday finery. Special exhibits include hand-painted and ceramic Santa Claus figures.

The Plymouth Historical Museum, located at 155 S. Main Street in Plymouth, is open to the public Thursday, Saturday and Sunday from 1-4 p.m. Admission is \$1 for adults, 50 cents for youth (11-17) and 25 cents for children (5-10). For more information call 435-8940.

**DSO "Messiah":** The musicians of the Detroit Symphony Orchestra will perform Handel's *Messiah* at 8 p.m. Saturday, Dec. 12, and 3 p.m. Sunday, Dec. 13, at Orchestra Hall on Woodward Avenue. Admission is \$10 general, \$15 for Loge seats and \$25 for box seats. Tickets are available from the box office, 833-3700, or at all Ticket Master outlets.

Information about other holiday festival concerts is available over the Musicians' Concert Hotline at 559-1987. All proceeds from the concert will go toward musicians' insurance benefits during the current DSO strike.

Hall at the college at 1-96 and Levan Road in Livonia. Soloist Anita Arslanian of Novi will assist the chorale in its program of carols from around the world. Admission is free; for more information call 591-5097.

**Upcoming at the Ark:** Concerts scheduled at the Ark, 827 1/2 Main in Ann Arbor (above the South Main Market) include: The 17th Annual Ark Celtic, Friday through Sunday, Dec. 11, 12 and 13, 8 p.m.; Sally Potter, Tuesday, Dec. 15, 8:30 p.m.; and Heather Bishop, Thursday, Dec. 17, 8:30 p.m.

**OCC Chorale:** The Oakland Community College Chorale will present a holiday concert at 8 p.m. Tuesday, Dec. 15, in the Wallace F. Smith Performing Arts Theatre. Full choral works will be included in the program of the pop and sacred seasonal selections, along with solo and ensemble performances. Admission is free, and the public is invited. The theater is on OCC's Orchard Ridge campus at 1-96 and Orchard Lake Road in Farmington Hills. For more information call 471-7700.

**"A Christmas Carol":** Meadow Brook Theatre's annual presentation of Charles Dickens' *A Christmas Carol* is open for a four-week run. Tickets can be reserved by calling the box office, 377-3300; for group sales or reservations for a Dec. 15 performance for the hearing impaired, call 370-3316.

**Photo exhibit:** Madonna College will present a student photography exhibit through Dec. 15 in the Exhibit Gallery/Library Wing. The exhibit is open to the public at no charge; hours are 9 a.m. to 9 p.m. weekdays and 1-4 p.m. on weekends. The college is at 1-96 and Levan Road in Livonia.

**Print show:** Henry Ford Community College and Lakeside Galleries presents an Antique and Contemporary Print Exhibition and Sale at Sission Gallery, Monday through Friday from 9 a.m. to 4 p.m. through Dec. 19. The gallery is at 5101 Evergreen Rd. in Dearborn.

**Madonna Chorale:** The Madonna College Chorale will present its annual Christmas Concert at 7:30 p.m. Sunday, Dec. 13, in Kresge

Performances of "A Christmas Homecoming" are scheduled for 8 p.m. Friday and Saturday, Dec. 11 and 12, and for 4 p.m. Sunday, Dec. 14. The school is located at Canton Center Road and Joy Road in Canton.

Tickets are \$5 for adults and \$4 for seniors and children. Group rates are available. Tickets are sold at the Giffrier in downtown Northville, Sideways in Plymouth and Bookbreak in Canton, as well as by any chorus member. For ticket information call 455-4800.

Organized in 1973 with less than 25 members, the chorus now contains 140 voices from throughout the area under the direction of Michael Gross of Westland.

Selections are set to include "O Come All Ye Faithful," "Winter Wonderland," "White Christmas," "Silent Night" and many others.

The chorus kicked off its Christmas concert season with an appearance at the Festival of Trees at Cobo Hall Nov. 24 to benefit Children's Hospital of Michigan. The chorus is also scheduled to sing at Livonia Mall at 7:30 p.m. Tuesday, Dec. 15.

The 14th annual concert by the chorus will feature sacred and secular songs of the Christmas season, including arrangements by Harry Simcoe, Norman Luboff, John Ness Beck and Robert Shaw.

Selections are set to include "O Come All Ye Faithful," "Winter

Handcrafters Unlimited  
CHRISTMAS  
**ARTS & CRAFTS SHOW**  
at the  
Northville Recreation Center  
1 1/2 blks. west of Center St.  
(Sheldon Rd.)  
On Main Street-Northville

FRI., DEC 11... 10-9 p.m.  
SAT., DEC 12... 10-5 p.m.

Over 60 Quality Artisans  
SORRY - Due to Crowded Conditions No Strollers Please  
Admission \*1 - Lunch Available

While you are in town, plan to visit our store located at  
342 E. Main - Northville  
(3 blocks E. of Show)  
348-0130

RESERVED

**AIRPORT PARKING FOR THE HOLIDAYS**

Budget Airport Parking will guarantee you reserved space for the holiday. Simply complete and mail the form below to "Thanks Budget—for peace of mind."  
We accept checks or credit cards and provide transportation to the airport in large roomy buses.

Customer name \_\_\_\_\_  
Address \_\_\_\_\_  
Date of departure \_\_\_\_\_  
Date of return \_\_\_\_\_  
Mail cost \$7.00 per day \_\_\_\_\_  
Name here payable to Budget Airport Parking (check number, company check) \_\_\_\_\_  
Credit card number \_\_\_\_\_  
City/State \_\_\_\_\_

Reservations must be received two weeks prior to departure.

Budget Airport Parking  
8715 Wickham Rd • Romulus, MI 48174 313-226-6880

## Top Ten

Here are the top ten selling books at B. Dalton Booksellers in Twelve Oaks Mall:

1. "Tommyknockers" Stephen King
2. "The Webster 20th Century Dictionary"
3. "Time Files"—Bill Cosby
4. "Kalidocscope"—Danielle Steele
5. "Family: The Ties..." Erma Bombeck
6. "Free to be a Family" Mario Tamara
7. "Sewin Stories..." Leo Buscaglia
8. "Man of the Hour"—Tip O'Neil
9. "Well"—Bob Woodward
10. "Heaven and Hell"—John James

## Plymouth chorus presents annual Christmas concert

The Plymouth Community Chorus is scheduled to present its annual Christmas concert, "A Christmas Homecoming," this weekend at the Plymouth-Salem High School Auditorium.

**Come Home for Christmas!**

**NORTHVILLE UNITED METHODIST CHURCH**  
8 Mile & Taft Road  
Eric Hammer, Pastor

Sunday, Dec. 13—ADVENT SERVICES  
9:30 & 11:30 a.m.

Sunday School & Adult Bible Study

Special ALL-CHURCH CHRISTMAS PROGRAM  
"Twas the Light Before Christmas"  
6 p.m., followed by Social Hour

Youth Club, Wednesday Nights  
Grades 4-12  
Choir, Bible Study & Recreation

**Ho-Ho-Ho Happy Holidays**

at the  
**Holiday Inn Farmington Hills**

**Breakfast With Santa**

Saturday, December 12, 1987  
10:00 a.m. in Maxwell's  
\$5.50 per person  
(including tax and gratuity)

Celebrate the holiday season with delectable Danish, savory scrambled eggs, bountiful bacon and juice. The kids will love a visit with Santa, free gift and candy cane. A picture with Santa is available for an additional \$2.00.

Reservations Required  
477-4000 ext. 180

**Holiday Inn**  
3023 West 10 Mile Road  
Farmington Hills, MI 48031

Introducing **Scan-Alert** Service.

Because the gap between security and no security is very small indeed.

You may be thinking about investing in an alarm system to protect your business or residence. Or you may have already invested in one. But what happens if an intruder cuts the line to that system? In most cases, the system shuts down. Unless you have new Scan-Alert® service. Scan-Alert service is an inexpensive addition for most alarm systems that use your phone line to transmit a signal to your alarm company. So not only can emergency calls get through, the system is also automatically triggered if the telephone line is cut or tampered with. Definitely a worthwhile investment for your peace of mind.

PLEASE NOTE: Michigan Bell's responsibility is limited to the transmission link between your business and your independent alarm company's monitoring facility.

Michigan Bell  
AN AMERITECH COMPANY  
Helping you communicate.

Protect yourself with Scan-Alert service by contacting one of the following participating alarm companies:

AMERICAN PROTECTIVE ALARMS, INC. 14771 W. Eight Mile Rd. Detroit, MI 48235 313-864-8600	CENTRAL ALARM SIGNAL, INC. 13400 W. Seven Mile Rd. Detroit, MI 48235 313-864-8900	GUARDIAN ALARM CO. 20800 Southfield Rd. Southfield, MI 48075 313-423-1000	SENTINEL SECURITY SYSTEMS 16143 Wyoming Ave. Detroit, MI 48221 313-342-2600
AUDIO SENTRY CORPORATION 31807 Utica Rd. Fraser, MI 48026 313-294-4410 313-540-9272	EAGLE SECURITY SYSTEMS Sears Installed Home Security Systems 1220 13 Mile Rd. Warren, MI 48093 313-751-0380	SECURITY CORPORATION OF MICHIGAN 1505 E. Eleven Mile Rd. Royal Oak, MI 48067 313-545-6665 1-800-482-4842	WHALL CENTRAL SECURITY 30633 Schoolcraft Livonia, MI 48150 313-522-7404



# Grapplers take 2nd at Belleville

By PHILIP JEROME  
managing editor

It's not that Tom Fritz was unhappy with Novi's second-place finish in the highly-regarded Belleville Invitational Wrestling Tournament.

It's just that Fritz has a deep-seated belief that second place is nowhere near as good as first.

The Novi grapplers kicked off the 1987-88 season by finishing second in the 12-team Belleville Tourney last Saturday — a scant three points behind the tournament champions from Gibraltar/Carlson.

Carlson accumulated 230 1/2 points to edge Novi (227 1/2 points) for the team championship as the two squads dominated the meet. Plymouth Canton finished a distant third with 129 points.

And even though Fritz said he was pleased with his team's performance, he made it obvious that he would have been significantly more pleased with a first-place finish.

"We had seven people in the finals and they (Carlson) only had six," reported the veteran Novi mat coach.

"We met them twice in the finals, and they won both matches. If either one would have gone the other way, we would have won the overall championship."

Another major factor in the outcome of the tournament was that Novi's top grapplers seemed to draw more than their fair share of byes in the opening round. "We have five 'buses' on this team, and all but one of them drew a bye in the first round," Fritz noted.

"You get two points for each opening round victory, so you could have won the tournament if just two more of our 'buses' could have wrestled in the opening round."

Despite having to settle for second place, however, the Wildcat grapplers looked impressive at the meet. Gibraltar Carlson is considered to have one of the state's better wrestling programs, and the Wildcat grapplers stayed with them all the way.

For the record, the Wildcats had three tournament champions and four more grapplers who finished second — and when you stop to consider that there are just 13 weight classifications in high school wrestling, having representatives in the tournament finals in seven divisions is not too shabby.

Winning individual championships for Novi were Ron Nutt at 112, Scott Brown at 136 and Brett Keir at 158.

"Ron (Nutt) just dominated the 112-pound class," reported Fritz. After drawing a bye in the first round, Nutt pinned his next two opponents in the first and second periods respectively before deciding Ypsilanti's Jamie Castel 6-1 for the tourney championship.

Brown was just as dominant en route to the 136-pound crown. After another of those costly first-round byes, Brown pinned his next two opponents in 15 seconds and 2:14 respectively to advance to the finals where he decisively beat Edsel Ford 7-6. "It wasn't that

close," said Fritz of Brown's victory in the finals. "Scott was very aggressive, shooting for the pin, and he gave up some points he wouldn't have if he had been wrestling more conservatively."

Keir accounted for Novi's third championship, pinning all three of his opponents en route to the 158-pound title. After a first-round bye, Keir pinned his first opponent in 4:37, flattened his next opponent in 27 seconds and then pinned Northville's Mike Hale in 1:50 in the championship final.

Adding second-place finishes for the Wildcats were Dave Brogan at 132, Dan Brogan at 138, Matt Brinker at 167 and Ron Fritz (the coach's son) at 185.

Although Fritz was pleased with several of his grapplers, he was particularly pleased with the performances of the Brogan twins in the 132 and 138-pound divisions.

Dave Brogan had a first-round bye, then pinned his next two opponents before losing to Belleville's Tim Clearwood 12-6 in the finals. One of Brogan's pins came at the expense of top-seeded Tom Sloan of Adrian.

Dan Brogan's second-place finish at 138 was even more pleasing because he was unseeded. After pinning his first opponent, Brogan pinned the third seed and decided the second seed before being pinned by Adrian's Albert Peres, one of the state's top 138-pounders, in the finals.

Brinker at 167 had another of those first-round byes, then pinned his next two opponents before losing 10-2 to

Carlson's Scott Berford in the finals, while Fritz decided his first opponent and pinned his next two opponents before dropping a 7-5 decision to Carlson's Dennis Szymankiewicz in the finals.

"Ron (Fritz) did a super job because he's wrestling a class higher than he ought to be," commented the Novi coach. "Szymankiewicz finished fourth in the state last year and Ron only lost by two points. The thing is that I think he could have beat him. As his father, I'm very proud of him. As his coach, I think he should have beat him."

Another major surprise came at 98 pounds where Brian Paquette finished third despite being only a freshman.

Fifth-place finishes came from Dan Rickfelder at 145, Andy Price at 155 and sophomore Bob Ahrens at heavyweight.

The only Novi grapplers who did not place were a pair of freshmen — Chris Wenzara at 105 and Mike Gowans at 119. But even their performances brought a smile to the face of their coach.

"One of the things that was very pleasing to me was the performance of our freshmen," commented Fritz. "Everybody in the line-up added points to the total by winning at least one match, and that included all three freshmen. The young kids showed me a lot. If they keep producing like that, we're going to be an awfully tough tournament team this year."

## Rec Briefs

**Men's over-30 basketball:** The Novi Parks and Recreation Department will hold an informational meeting for anyone interested in playing the men's over-30 basketball league. The meeting will be held in the Novi Parks and Recreation Building on Sixth Gate on Tuesday, Dec. 15, at 6:30 p.m. Call 349-1976 for more information.

**Youth floor hockey:** Boys and girls in grades 3-8 are eligible to sign up for the Youth Floor Hockey League sponsored by the Novi Parks and Recreation Department. The league will meet on Tuesdays and Fridays from 3:45 to 5:45 p.m. in the Novi Meadows gym beginning Jan. 5 and running through Feb. 5. There's a registration fee of \$17 per player which includes shirts and awards.

Floor hockey is a non-contact sport which stresses physical fitness, teamwork and fair play. Practices times and locations are subject to coach availability. Teams are co-ed. Call 349-1976 for more information.

**7-8th grade basketball:** The Novi Parks and Recreation Department offers a 7th & 8th Grade Basketball League with separate divisions for boys and girls. The league will meet on Tuesdays and Fridays from 3:45 to 5:45 p.m. in the Novi Meadows gym beginning Jan. 5 and running through Feb. 5. There's a registration fee of \$15 per player and registration deadline is Monday, Jan. 4, at 5 p.m. There will be a mandatory meeting for all players on Tuesday, Jan. 5, at 2:40 p.m. For more information call 349-1976.

**Officiating classes:** Officiating classes in basketball, soccer, softball, baseball and volleyball are being offered through the Walled Lake Community Education Department. Participants who complete the class can be state certified and registered.

Each class runs two hours per night for three weeks. Call Walled Lake Community Education at 624-0202 for more information or registration.

**Swimming instructors:** The Walled Lake Community Education Department is looking for swimming instructors for its winter program. The rate of pay is \$7 per hour, and applicants must be WSI certified. Call 624-0202 for more information or an application.

**Equine seminar:** Schoelcraft College will host a day-long Colic Symposium for Horsemen on Sunday, Dec. 13, beginning at 9 a.m. Designed for owners and trainers, the symposium will discuss early diagnosis and treatment of colic, the number one cause of death among horses. Veterinarian instructors Michael Hall, Jim McInuray and Steve Rymal are associated with the Oakland Equine Center in South Lyon. They will discuss treatment of both medical and surgical colic cases. Participants will learn the signs of colic, how to monitor the vital signs and when to call a veterinarian. Registration will begin at 8:15 a.m. in the Liberal Arts Building (Room LA-200). The \$20 fee includes coffee, lunch and handout materials. For more fee and registration information call 391-6400, extension 409.

**T-Ball Committee:** The Novi Parks and Recreation Department is looking for individuals interested in serving on a T-Ball Committee. Contact Kelley Simpson at 349-1976 for more information.

## Novi Christian cagers off to fast start

The Novi Christian cagers are off to a fast start with four victories in the first five games of the 1987-88 season.

Following an 89-69 conquest of Greater Life Academy of Pontiac in the season opener, the Eagles entered Calvary Christian's Tip-Off Tourney in Ypsilanti and won two of three games to finish in second place.

The Eagles upped their record to 4-1 last Friday

with a 74-57 victory over Calvary Christian. Calvary held a 33-31 lead at the half, but Novi Christian roared back to assume control of the game as 6-5 senior center Paul Walker asserted himself in the paint and poured in 12 of the Eagles' 26 third-quarter points to leave Calvary behind 57-46 at the three-quarter mark.

The Eagles were led in the scoring department by senior point guard Eric Jacobs who tallied 26

points to put his season's average to 20.4 points per game. Jacobs has now scored 57 points over the last two games.

Walker finished with 22 points and led the Eagles in rebounding by pulling down 14 caroms. Novi out-rebounded Calvary by a 56-34 margin.

Walker got plenty of help under the boards as forward Jim Gardner and guard Travis Forta each collected 11 rebounds.



### HERE'S \$5.00 TO GET YOU STARTED.

—Chuck Yeager

A rebate offer like this one ought to get you all charged up for the winter.

Buy a top-quality Delco Freedom or Dura Power 50, 60, 72, or Voyager battery between October 18, 1987, and December 19, 1987, and you'll come out \$5.00 ahead. (Go for a 40-series battery and you'll save \$2.00.)

All participating AC Delco retailers have rebate coupons and details. Look for the one nearest you—he's listed at the bottom of the page.

While you're there, don't forget to ask about Delco's expressed limited nationwide warranty that applies to all batteries.

But you better get your tail moving. All requests must be received by December 31, 1987.



## AC-DELCO. THEY DON'T JUST FIT. THEY MATCH.

### DELCO BATTERIES AVAILABLE AT THESE RETAILERS:

- |   |   |   |   |  |
|---|---|---|---|--|
| <b>BRIGHTON</b><br>Autoworks<br>8873 W. Grand River<br>(313) 227-4499 | <b>HIGHLAND</b><br>ACO<br>2850 Highland Rd.<br>Highland Auto Sup.<br>315 N. Milford Rd.<br>(313) 887-4126 | Mels Auto Supply<br>754 S. Michigan<br>(517) 546-8275 | <b>NEW HUDSON</b><br>Hans Auto Electric<br>5450 Grand River<br>(313) 437-1717 | <b>NOVI</b><br>ACO<br>41800 W. Ten Mile Rd.  |
| Grundy Howe<br>8399 Grand River Ave.<br>(313) 227-6123                | <b>MILFORD</b><br>ACO<br>530 Highland Avenue<br>Perry Drug<br>660 Highland St.                            |   | <b>NORTHVILLE</b><br>RPM Auto & Ind Pnts<br>31135 Ryan<br>(313) 751-3500      | <b>WALLED LAKE</b><br>ACO<br>1116 W. Maple<br>Murrays Discount<br>707 N. Pontiac Tr.<br>(313) 624-8767 |
| Mechanics Auto Sup.<br>4990 S. US 23                                  | <b>HOWELL</b><br>Grundy Howell<br>1250 E. Grand River<br>(517) 546-9072                                   |   |   |  |

## CUSTOM DECK EXPERTS

Let us help you design a deck to compliment your home and satisfy your outdoor needs.

We feel that pressure treated Ponderosa Pine is the best material for the job. It's retention. It has a better appearance, less warping and less splitting than Yellow Pine.



Lumber is guaranteed for 30 years. Free Design Service

Free Delivery Within A 70 Mile Radius

## H.A. SMITH

Lumber & Supplies  
28575 Grand River (near 8 Mile)  
Hours: Monday-Friday 7:30-5:30; Saturday 8:00-4:30  
474-6610 or 535-8440

Everything in Treated Lumber

## McMartin's

Diamonds & Fine Jewelry  
At Commecree and Main  
Milford 684-8895



Novi News/STEVE FECHT

This quartet of Novi High School swimmers lifted the Wildcats to their best-ever finish (13th place) in the MHSAA Class A championships last weekend. They are Beth Surowiec (seated) and Julie Sommers, Chris Marker and Gwen Rowlands (standing, left to right).

## Rowlands sparks tankers

Continued from 1  
time in Friday's prelims with a time of 1:56.37 to head into the finals with the third fastest time in the state. She turned in a 1:56.70 in the finals to claim fourth place.

Surowiec, who was the only Wildcat to qualify for the state meet last year, also had a strong meet, finishing eighth in the 100 backstroke and 18th in the 200 individual medley.

Surowiec was ranked 14th in the backstroke but qualified for the finals on Saturday by finishing ninth with a time of 1:02.49 in the prelims. She moved up another notch on Saturday, finishing eighth with a time of 1:02.01.

She was not as fortunate in the 200 IM, however. Entering the meet seeded 16th, she went 2:16.87 in the prelims which left her 13th — one spot away from qualifying for the finals.

The biggest improvement of all came from the 400 freestyle relay team of Surowiec, Sommers, Marker and Rowlands. They entered the state meet ranked 25th, but moved up 16 spots to ninth place and qualified for the

finals by turning in a fine 3:45.43 clocking in the prelims. On Saturday, the Wildcat quartet turned in a better time (3:45.20) but dropped one spot to end up in 10th place.

In addition to 24 points and a 13th place finish in the state, the Novi tankers also set six new school records. New standards were established by Rowlands in the 100 freestyle (53.52) and the 200 freestyle (1:56.37), Surowiec in the 100 backstroke (1:02.01) and 200 IM (2:16.87) and the 400 freestyle relay quartet (3:45.20).

In addition, Rowlands was credited with another school record in the 50 freestyle when she was clocked in 25.85 at the halfway mark of the 100 freestyle in Friday's prelims.

Although ecstatic about his team's performance, Anderson said the meet was rewarding for himself as well. "From a coaching perspective, it was personally gratifying that all the girls peaked and posted their best times in the biggest meet of the season," he said.

"That's some indication that I was successful in my efforts in helping the girls achieve their objectives and meet their potential."

## Novi cross-country coach has high hopes for future

By NEIL GEOGHEGAN  
staff writer

Forget the numbers, forget the statistics, forget the records — Wildcat cross-country Coach Bob Smith believes his 1987 team was by far the best in Novi history.

"The 'Cats only finished fifth in the seven-team Kensington Valley Conference, but the league consistently produces some of the best cross-country teams in the state. To finish out of first place in the KVC isn't something to hang your head about."

"I believe this team was the best we've ever had at Novi," Smith said. "The talent level was obviously the best in terms of raw numbers — we are deep and young."

"The other fact that made us so successful was the attitude of the kids. These guys aren't afraid to work hard and we have leaders."

So, was this the season Novi finally turned the corner after years of mediocrity in boys' cross-country? Can the team finally start to realistically think about contending for the league title and keep up with the Lakelands, Hartlands and Milford on their schedule?

"We've definitely turned the corner," Smith asserted. "Next year we'll be right in the thick of the fight for the crown."

"I never would have believed he could have gone this far," Smith admitted. "Even from his phenomenal season a year ago, he made a quantum leap from our number one to one of the state's best."

"He really improved. He's a gamer, but he's loose — he doesn't let the pressure get to him."

Rasmussen is the first Novi runner in history to break the 17 minute barrier at Cass Benton Park, and Smith compares him favorably to former Wildcat running stars like Jeff Johnston and Jim Kohli. But keep in mind that Rasmussen isn't finished yet — he still has a senior season to complete.

"He's our best runner in terms of physical tools," Smith said. "Jeff Johnston was a premier runner for Novi before my time and Jim Kohli was another runner who made it to the state meet, and I don't want to

**Smith: 'I believe this team was the best we've ever had at Novi. The talent level was obviously the best in terms of raw numbers — we are deep and young.'**

take anything away from them, but I believe Rob will be the best we've ever had before he is done."

Van Dyke was constantly "on Rasmussen's tail all season long: He was the runner-up finisher for the Wildcats in every single dual meet, and complements Rasmussen very well. Smith knows Van Dyke has been in Rasmussen's shadow much of the time, but also knows that it doesn't diminish his achievements."

"In any other year, Bret would be our number one man by at least 30 seconds," Smith said. "He just happened to be on the team along with another great runner, but his times this season are a half-minute better than anybody last year and a full minute better than anybody before that."

One of the biggest surprises for Smith was that three of his top seven runners were new to the team — number three runner Rob 'Neil, number four Lee McMains' and number six Ron Herman.

"My number seven man this year, who barely made varsity, would have been our number three man last year — that's how far we've come in a year," Smith pointed out.

## MAKE DREAMS COME TRUE...



## THROUGH TOYS FOR TOTS!

You'll get FREE INSTALLATION of Cable TV for donating a toy! Make the dreams of needy children in this area come true this Christmas ... just bring us a new toy and we'll install great entertainment in your home FREE! You'll see all the exciting entertainment choices that only cable television has to offer.

If you already have Cable TV, you can add a premium service FREE by donating a toy!

The toy need not be expensive, simply something you would give your own child. So why not make a child happy and treat yourself too this Christmas with free installation of Cable TV for a new toy.

Bring us a toy by December 18 and make plans to share the joy of giving.

- |   |   |  |
|---|---|--|
| Metrovision of Redford<br>25000 Capitol Ave.<br>Redford Township, MI 48239<br><b>538-1313</b> | Metrovision of Oakland Co.<br>37635 Enterprise Court<br>Farmington Hills, MI 48018<br><b>553-7300</b> | Metrovision of Livonia<br>14525 Farmington Rd.<br>Livonia, MI 48154<br><b>422-3200</b> |
|---|---|--|

**CHARLES W. WARREN**  
JEWELERS SINCE 1902

SOMERSET HALL (513) 949-2411  
LANSING — LANSING — LANSING  
TWELVE OAKS

Use our own Silver Card or we welcome American Express, Visa or MasterCard

**MetroVision**





# Gifts Galore

*For Everyone  
On Your List*

In the very merry spirit of Yuletide joy and cheer, we're celebrating Christmas throughout the stores right here! Each merchant has been busy stocking up on gifts galore...to provide the best selection of everything and more! They've worked to have it festive and filled with cheer and fun...so that shopping here is a delight for everyone.

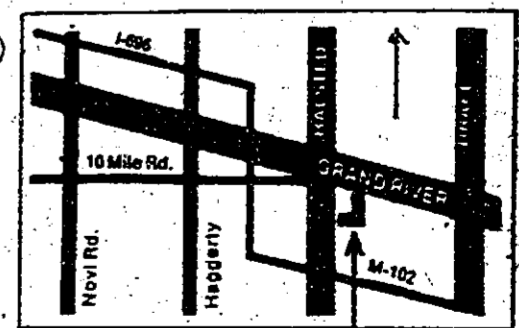
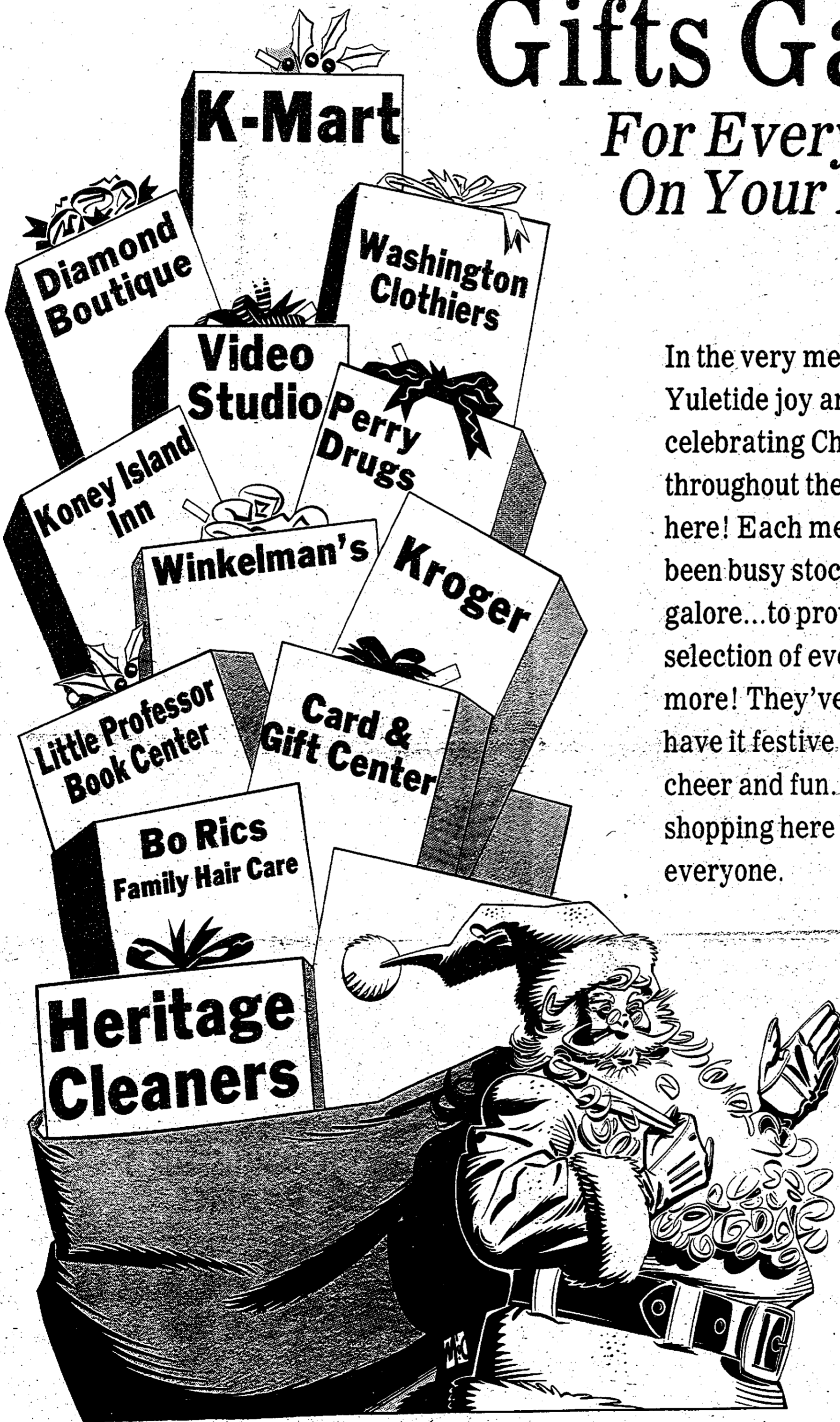

Grand River/Haisted Plaza



## BOOKS

### GIFTS THEY'LL OPEN AGAIN AND AGAIN

No gift is as welcome as a good book. Regardless of the age or interests of the recipient it is truly a present which will be opened again and again.

Let us help you make everyone on your gift list happy this holiday.

We have a great selection of books of all kinds, in hardcover or paperback. And we offer free gift wrapping and speedy ordering.

- |                    |                           |
|--------------------|---------------------------|
| <b>BESTSELLERS</b> | <b>COFFEE TABLE BOOKS</b> |
| <b>CLASSICS</b>    | <b>MYSTERIES</b>          |
| <b>ROMANCES</b>    | <b>SCIENCE FICTION</b>    |
| <b>ART</b>         | <b>DO-IT-YOURSELF</b>     |
| <b>REFERENCE</b>   | <b>BUSINESS</b>           |
| <b>HISTORY</b>     | <b>SELF HELP</b>          |
| <b>CHILDRENS</b>   | <b>BIOGRAPHY</b>          |

And stocking stuffers.....

- |                          |                        |
|--------------------------|------------------------|
| <b>GIFT CERTIFICATES</b> | <b>BOOKPLATES</b>      |
| <b>BOOKMARKS</b>         | <b>CRAZY GAMES</b>     |
| <b>AUDIO CASSETTES</b>   | <b>MUSIC CASSETTES</b> |
|                          | <b>PICTURE PUZZLES</b> |

*We'll Help You Find Books They'll Love*

**Little Professor Book Center**  
37115 Grand River at Halsted  
Farmington **478-2810**  
Mon-Sat. 10AM-9PM Sun. 10AM-5PM



**ADVERTISED ITEM POLICY. WE RESERVE THE RIGHT TO LIMIT QUANTITIES**  
Each of these advertised items is required to be readily available for sale in each Kroger store, except as specifically noted in this ad. If we do run out of an advertised item, we will offer you your choice of a comparable item, when available, reflecting the same savings or a raincheck which will entitle you to purchase the advertised item at the advertised price within 30 days. Only one vendor coupon will be accepted per item. Copyright © 1987, The Kroger Co. No Sales To Dealers.

Prices Good Thru Sun., Dec. 13, 1987

**37025 GRAND RIVER  
GRAND RIVER & HALSTEAD**

**STORE HOURS  
MONDAY THRU SATURDAY**

**8 AM to 10 PM  
SUNDAY 9 AM TO 6 PM**

10-Lbs Or Larger  
**ASSORTED  
PORK CHOPS**  
**\$1.99**  
Lb

U.S.D.A. Choice Grain Fed  
3/4" Trim Beef  
**BONELESS  
ROUND STEAK**  
**\$1.69**  
Lb

5 Bloom And Up  
**HOLIDAY POINSETTIAS** 6-Inch Pot **\$5.49**

Fresh Cut, With Christmas Greens  
**HOLIDAY MIXED BOUQUETS** Each **\$4.49**

All Purpose  
**GOLD MEDAL FLOUR** 5-Lb Bag **88¢**

Assorted Flavors  
**BIG K  
POP**  
**59¢**  
2 Liter Bottle Plus Deposit

White Or Assorted Colors  
**NORTHERN  
BATH TISSUE**  
**97¢**  
4-Roll Pkg

**PARTY TRAY HEADQUARTERS**

Our Most Popular Tray!  
**CONNOISSEUR'S  
CHOICE**  
Moist, Pink Ham, Roast Beef, Savory Corned Beef and Tasty Turkey Breast along with American, Swiss and Muenster Cheese, accented with the dip or salad of your choice.  
**\$39.95**  
Large Size Serves 18 To 24 People  
Only **\$2.22 Per Person**  
Plus A FREE loaf of our Fresh Baked Rye Bread with your party tray purchase!

**DOUBLE COUPONS** Limited To Manufacturer's Coupon Valued Up To **50¢** See Store For Details



**Created For The Special Woman  
In Your Life...**

Eternity Bracelets

Diamond Necklaces

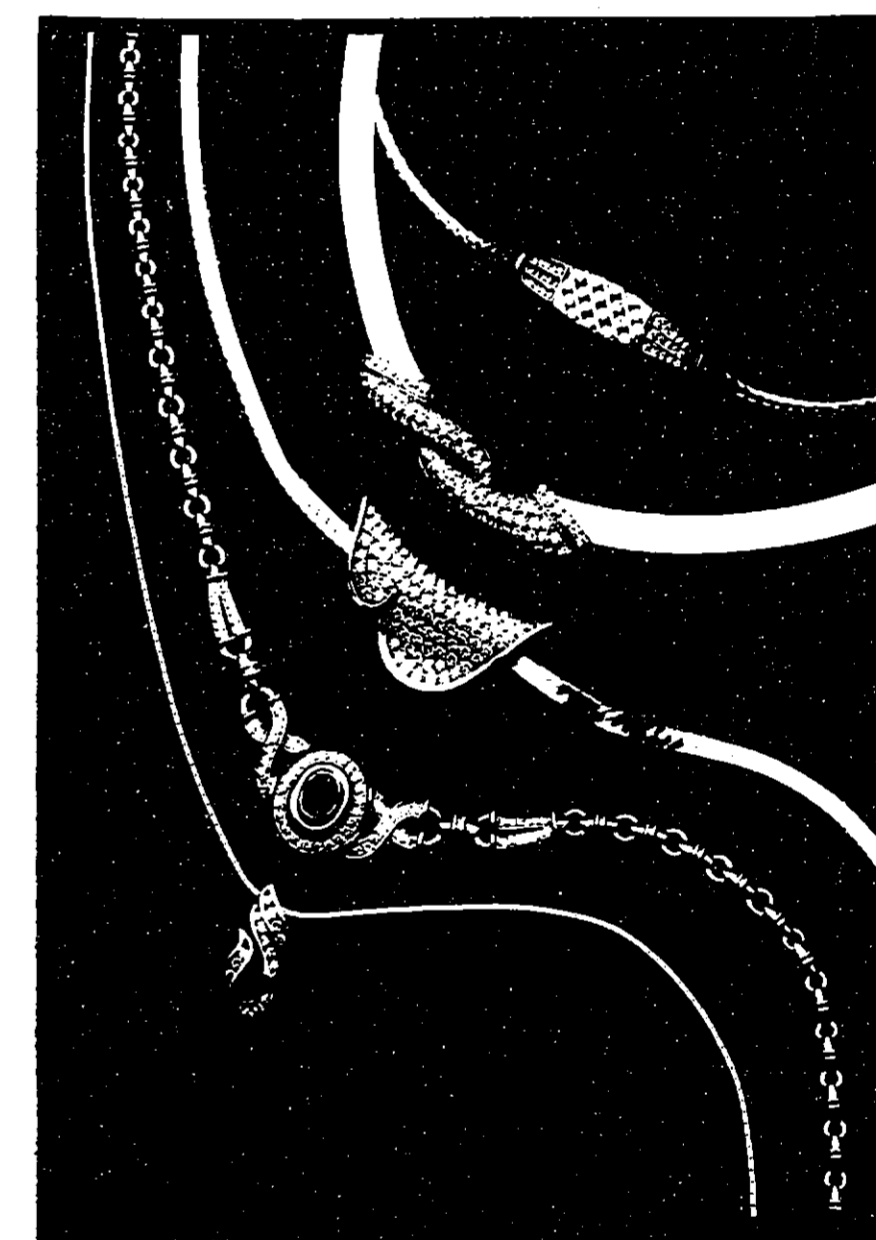
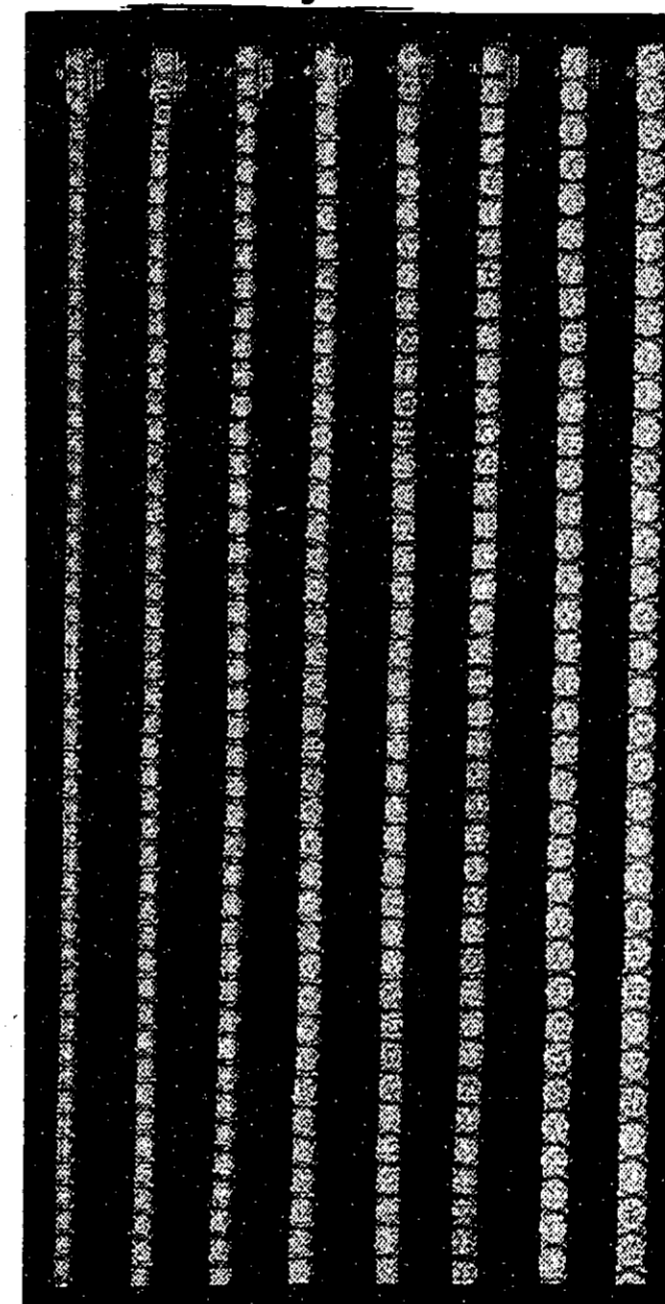

From \$1900 (2.65 ct of diamonds)  
To \$12,000 (13 cts of diamonds)

*Layaway Now  
For Christmas*

*New Designs  
Now Available For  
Holiday Gifts*

**diamond Boutique**

*Custom Made Jewelry Exquisitely Designed To Be Exclusively Yours*

37105 Grand River, Farmington  
Grand River/Halsted Plaza 478-3131

When you buy from Diamond Boutique you save 40% to 70% off retail because we manufacture our fine jewelry and pass the savings on to you

Major Credit Cards Accepted



holiday gifts  
holiday looks  
holiday styles  
now on  
**sale**

tremendous  
savings  
throughout  
the store

bringing fashion to life  
**winkelman's**

**SEND THEM NAUGHTY OR NICE!**  
New Letters from Santa for Children or Adults!

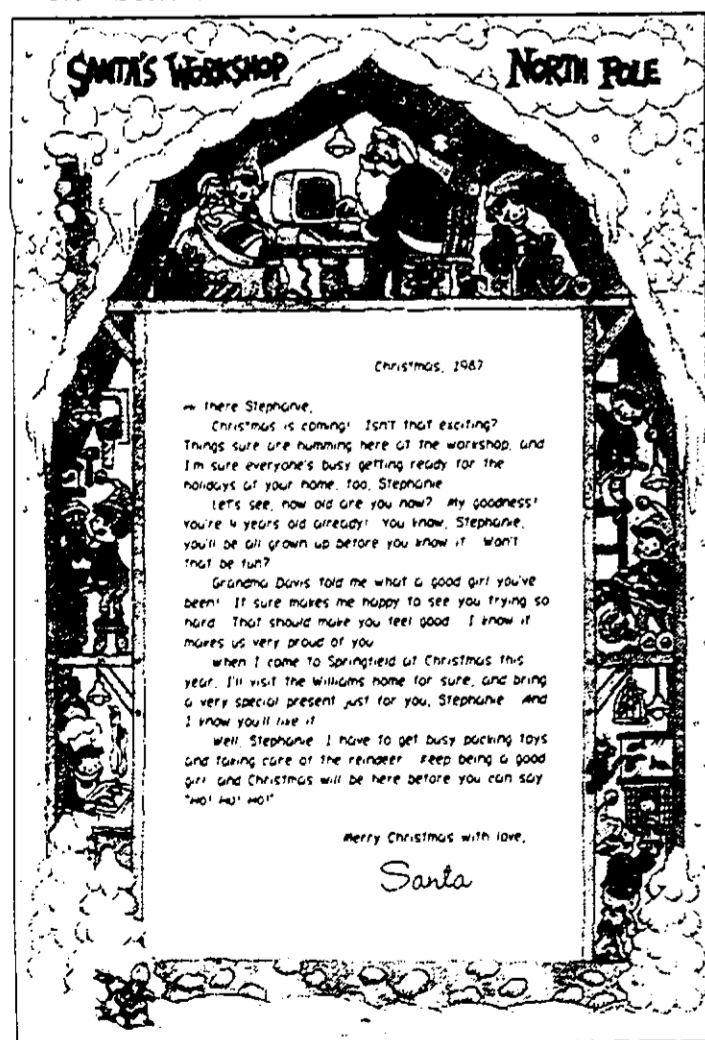

Two great new personalized letters from Santa carry the recipient's name, and yours! The "nice" one's for all the special kids in your life, and the "naughty" one is a tease—fun for adult family and friends. Created by Hallmark and printed in seconds—only \$2.50 each! Send them to everyone you know!

**START A  
KEEPSAKE ORNAMENT  
TRADITION.**

Start with  
"First Christmas  
Together"...



...add ornaments  
each year...

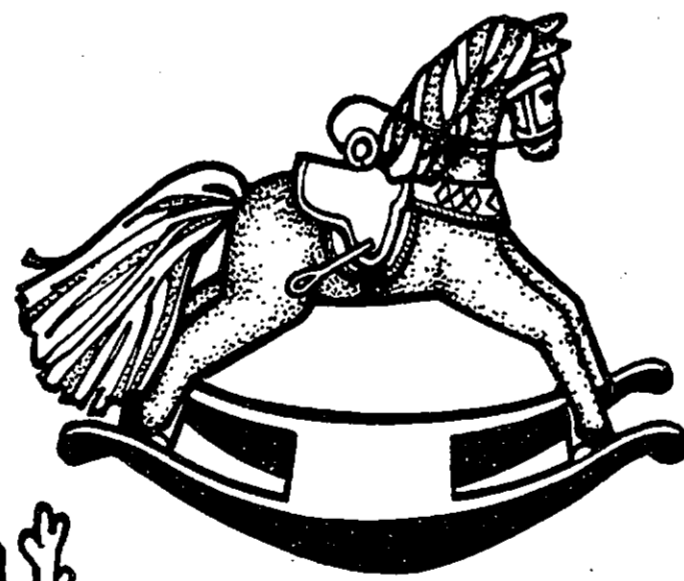

or pick from any of  
our fabulous  
series and give  
them as gifts!

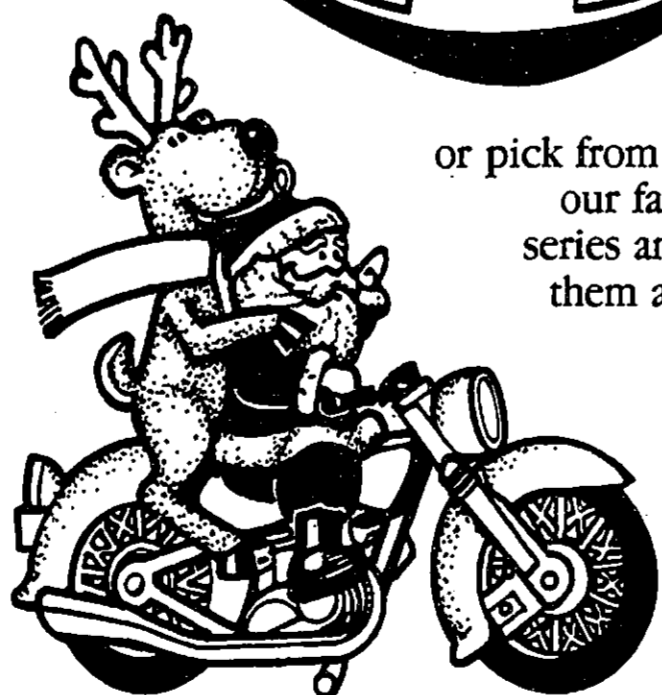

Hurry! Supplies are limited!

Hallmark

**Card & Gift Center**

478-3871

Your **Hallmark** Headquarters

Daily 9:30-9  
Sunday 12-5

**Great Movies - Low Prices!**

**GRAND RIVER/HALSTED PLAZA**

**VIDEO STUDIO**

37061 Grand River

476-1970

MON-SAT 10:30-9 p.m.  
Sun 12-6 p.m.

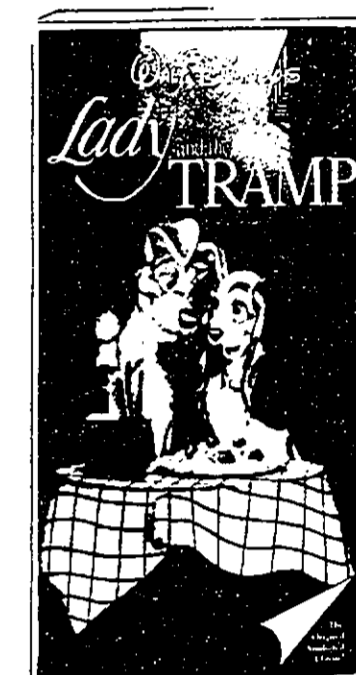

Announces its new

**VIP** RENTAL PROGRAM

VALUE ON RENTALS  
A \$30<sup>00</sup> VALUE ON RENTALS

ONLY **\$18<sup>99</sup>** Plus Tax



**TIN MEN**



**THE  
GOLDEN  
CHILD**

**STAR TREK: TV**  
THE VOYAGE HOME

VIP Cards entitle you to rent  
10 movies while paying just once!  
Saves time, saves money and makes  
renting more convenient than ever!

— **ASK FOR DETAILS** —

**Our Best Wishes  
For A Joyous Holiday Season**

# LAST MONTH WE GAVE EVERYONE A NEW REASON TO SMILE.



## WE OPENED OUR NEWEST BORICS

Last month, we cut more than hair. We cut the grand opening ribbon on the latest addition to BoRics Haircare. The great place to get a great haircut for just \$6.

Our trained professionals will give you a quality haircut. They'll wet down your hair with a special cutting solution, cut it the way you want and blow it dry.

Clean hair is necessary for accurate hair cutting. You can shampoo your hair on the day of your visit, or, for a small charge, we'll shampoo it for you. Because, at BoRics, you pay only for the services you need.

You can't beat BoRics for convenience, either. No appointments are necessary. Just walk into one of our convenient locations Monday through Friday 9 a.m. to 9 p.m., or Saturday 9 a.m. to 6 p.m.\*

Don't settle for the uninteresting styles of a barbershop or the high prices of a beauty salon. Stop into BoRics and let us give you a new reason to smile, too.

\*Mail hours may vary

**\$6**

FOR A GREAT HAIRCUT.  
Over 150 locations in the U.S. and Canada.

**\$1 OFF  
HAIRCUTS**

Great haircut. Great price. Great location. No appointment necessary.

**\$6 OFF  
PERMS**

Get a \$6 off on any perm. Prices for short hair, \$37 medium hair, \$42 long hair. Includes shampoo, cut and style. Coupon valid at any BoRics location. No appointment necessary.

**BoRics™  
HAIRCARE  
FOR EVERYONE**

**New Location**  
FARMINGTON  
37085 Grand River  
at Halstead  
Grand River/Halstead Center  
Phone: 471-0880

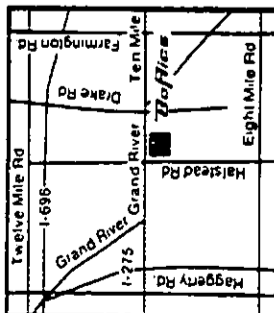

**OTHER LOCATIONS**  
**LIVONIA**  
19592 Middlebelt Rd.  
at 7 Mile Rd.  
Access from Livonia Mall  
Phone: 471-0880

**FARMINGTON HILLS**  
23908 Orchard Lk. Rd.  
at 13 Mile Rd.  
Phone: 626-4775

# KONEY ISLAND INN

Family Restaurant

(next to K-Mart)

Grand River at Halsted, Farmington

Now Open 7 A.M.

Monday - Friday

8 A.M. Sat. & Sun.

**Breakfast  
Special!**

2 Large Eggs with Meat,  
Hash Brown Potatoes  
Toast & Jelly

Mon.-Sat. 7-11:30 a.m.  
Sunday 8 a.m.-2 p.m.

**All For \$1.99**

Check Menu for Other Specials

**20% OFF**

Your Total Bill  
After 2 p.m. Only  
Expires Jan. 15, 1988

**Complete Fast  
Carryout Service**

**478-0440**

# Grand Opening! Heritage Cleaners

37073 Grand River at Halsted  
Farmington, MI 48024

Phone: 473-0100

Store Hours:

Mon. - Fri 7-8

Sat 8-6

Services:

1. 1 Hour Dry Cleaning
2. Shirt Laundry
3. Alterations
4. Suedes & Leathers
5. Pillows Cleaned
6. Reweaving

**50% OFF**

**All Incoming  
Dry Cleaning  
Orders**

With this coupon  
Heritage Cleaners  
Expires 1/31/87

**50% OFF**

**All Incoming  
Dry Cleaning  
Orders**

With this coupon  
Heritage Cleaners  
Expires 1/31/87

## Santa Suggests Great Gift Ideas From Washington Clothiers

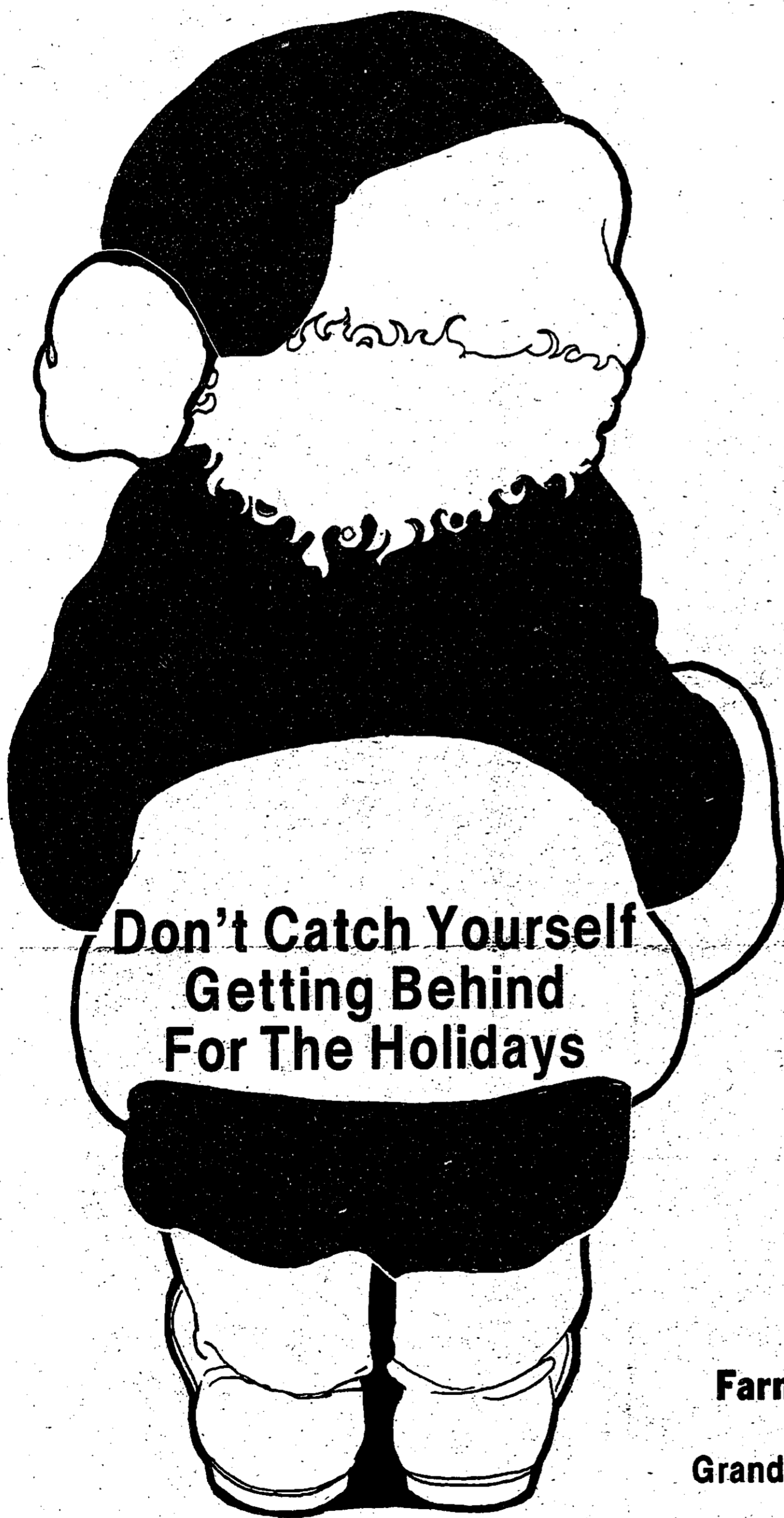

**Don't Catch Yourself  
Getting Behind  
For The Holidays**

- Suits and Sportcoats
- Dress Shirts
- Ties and Belts
- Shoes
- Golf & Casual Shirts
- Sweaters
- Coats & Jackets
- Jewelry and  
Accessories

**478-3430**



**Farmington's Only Complete  
Men's Store**  
Grand River at Halsted - Farmington  
Mon-Sat 10-9 Sun 12-5  
All Major Credit Cards Honored

# THANKS TO OUR GUARANTEED LOWEST PRICES CHRISTMAS COMES EARLY!



**DECEMBER SALE DATES**

SUN	MON	TUE	WED	THU	FRI	SAT
			9	10	11	12
13	14	15				

**WE WILL NOT BE BEAT!**

**BUILDERS SQUARE®**

**LOWEST PRICES GUARANTEED!**  
 We guarantee the lowest price on every item... everyday! And, if you find a lower price at a competitor (Heaven forbid) just let us know and we'll change it... plus we'll give you 10% more in SQUARE BUCKS for your next purchase. Identical items only (same manufacturer and model number.) Offer limited to items in stock. No rain checks. Price comparison is at the time of purchase. We reserve the right to limit quantities to dealers and competitors.

**344** GROWN IN 6-INCH CONTAINERS  
**BLOOMING POINSETTIAS**

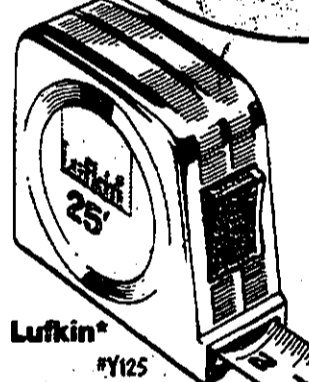

**1" x 25' ULTRALOK 796**

- Ultramath yellow blade
- Easy to read markings
- Write on, wipe off

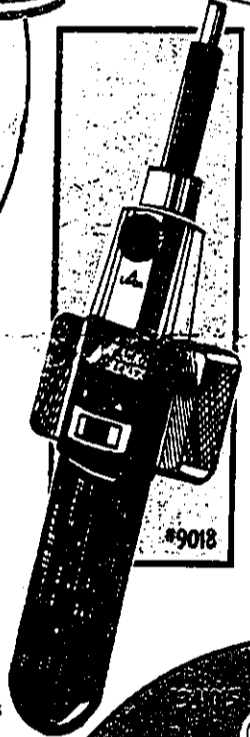

**\$17** CORDLESS SCREW-DRIVER

- Power screwdriving makes common household tasks easier and quicker
- Drives screws faster, and with less fatigue than manual screwdriver.
- Wall-mounting charging base, bit storage.
- Combination slotted and Phillips bits

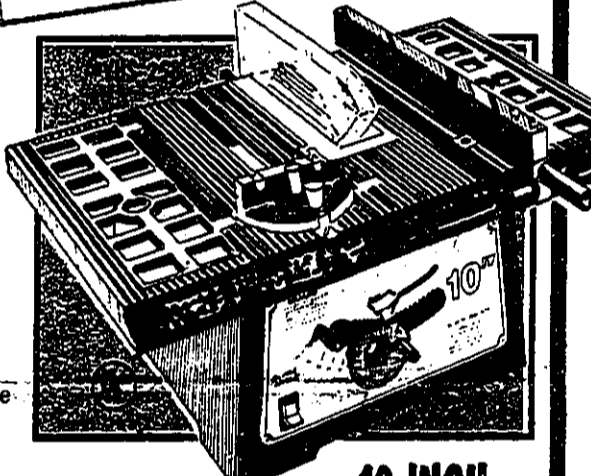

**\$79** 10-INCH BENCH TABLE SAW

- Heavy duty 10" saw
- Cuts to a maximum depth of 3-1/8"
- 2-1/2 HP motor
- Portable

**Northland** 2-TON FLOOR JACK **84**

**REGENT LIGHTING** QUALITY QUARTZ LIGHT **1050**  
 #EQ300WL  
 ALL-PURPOSE FLOODLIGHT  
 Includes 300 watt bulb  
 Uses normal house current  
 Adapts to any dimmer switch

**2-TON FLOOR JACK \$19**  
 #T-4021

**1/2 HP - PORTABLE AIR COMPRESSOR \$79**  
 Oilless design  
 Virtually maintenance-free  
 Includes air hose & tire chuck



**7-DRAWER ROLL-TOP DESK \$167**

- Ready to finish pine
- 45" H x 54" W x 20" D
- Completely assembled

**3M TRANSPARENT TAPE 50¢**  
 YOUR CHOICE:  
 1/2" x 450' OR  
 3/4" x 300'  
 • Dispenses easily  
 • Doesn't yellow  
 #105

**ENERGIZER BONUS PACK 496**  
 BONUS PACK C OR D BATTERIES  
 EVEREADY

**2-TON LIGHT SET 497**  
 Merry Midget 35

**OPEN SUNDAY**  
 For Your Convenience Our Store Hours Are:  
**7:30 am - 9 pm**  
 Monday thru Saturday  
**9 am - 6 pm**  
 Sunday

Limited quantities. Sorry, no rainchecks. At least one of each item available in the store at the beginning of the sale.



**BUILDERS SQUARE GIFT CERTIFICATES, NOW AVAILABLE!**  
 At Builders Square, you know you can always find exactly what you need, from our selection of over 30,000 items, and at the lowest prices in town. But, if you're stuck on what to give that special do-it-yourselfer or contractor on your Christmas list, remember Builders Square's Gift Certificates! They're available in any denomination, can be used toward the purchase of any of our products or services and best of all, they are always the right size and color! So, stop by our Courtesy Desk for the present that's always sure to please: Builders Square Gift Certificates.

©1987 BUILDERS SQUARE, INC.  
**NOW SEVEN DETROIT AREA LOCATIONS:**  
 8400 E. 8 MILE (BASELINE) BETWEEN VAN DYKE (53) AND HOOVER RD. IN THE OLD BEL AIR DRIVE IN 853-4900  
 IN LIVONIA • 30000 PLYMOUTH RD. AT MIDDLE BELT RD. ACROSS FROM WONDERLAND MALL (SOUTH OF I-96) 522-2900  
 IN ROY • 12 MILE RD. AT HOW RD. ACROSS FROM TWELVE OAKS MALL 344-8855  
 IN FLINT • 6365 MILLER RD. AT 775-733-7582  
 IN STERLING HEIGHTS • 12000 HALL RD. M59 AT M53 254-4640  
 IN SOUTHGATE • 14800 DIX-TOLEDO RD. AT EUREKA RD. 246-8500  
 IN MT. CLEMENS • 37555 S. GRATIOT 1 BLOCK N. OF METRO PKWY 468-0620



# THE LARGEST SELECTION OF POWER TOOLS IN TOWN AT PRICES YOU CAN AFFORD!

## POWER TOOLS BY BLACK & DECKER

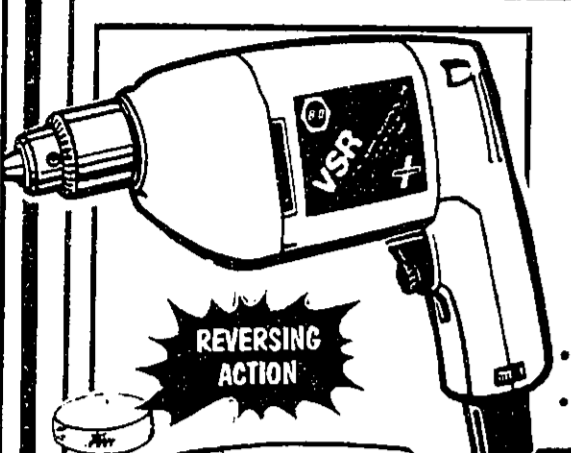

**3/8" VARIABLE SPEED DRILL**  
**\$26**

- Features variable speed with infinite speed lock and reversing action
- Double insulated and needs no grounding



**3/8" COMPACT CORDLESS DRILL**  
**\$39**

- Powerful 65 watt DC motor delivers high torque to punch through tough materials
- Trigger switch has forward & reverse
- Includes three hour charger & chuck key
- Compact, lightweight and streamlined

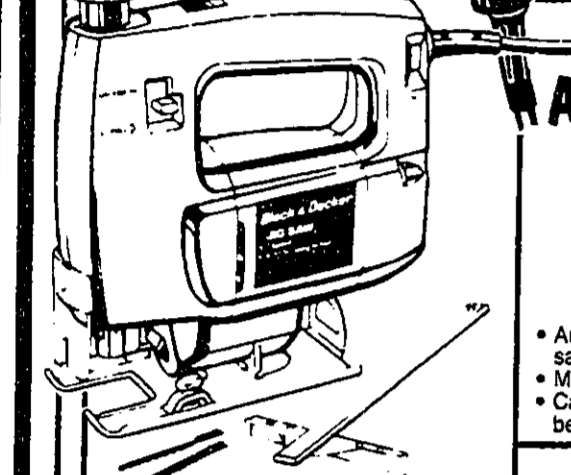

**TWO-SPEED AUTO-SCROLLING JIG SAW**  
**\$34**

- Auto-scrolling blade pivots in direction saw is guided
- Manual scrolling top knob rotates blade
- Calibrated shoe tilts 45° left or right for bevel cuts

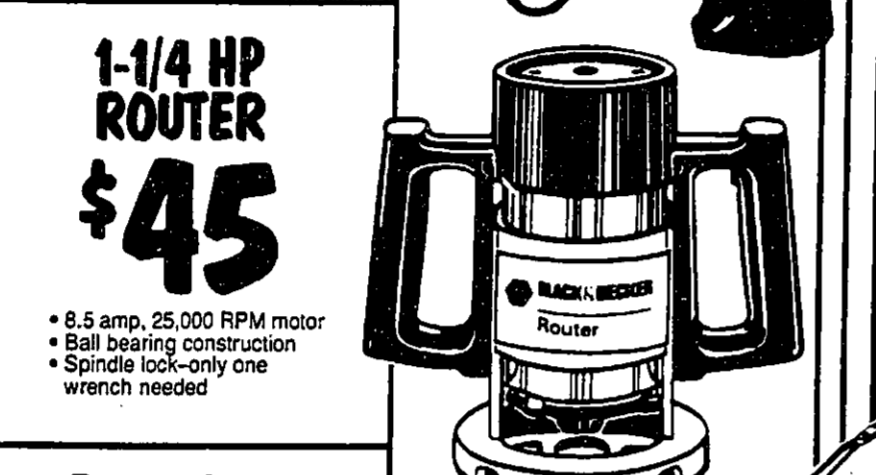

**1-1/4 HP ROUTER**  
**\$45**

- 8.5 amp, 25,000 RPM motor
- Ball bearing construction
- Spindle lock—only one wrench needed

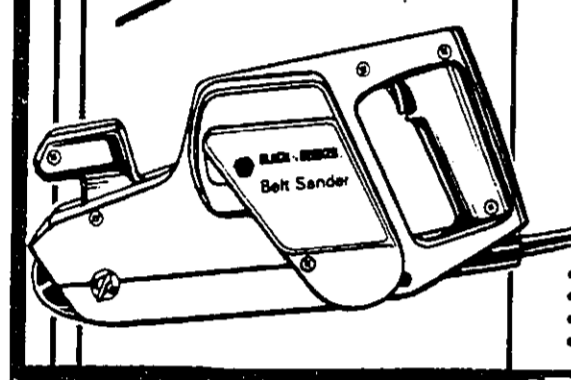

**3" x 21" BELT SANDER**  
**\$37**

- General purpose belt sander
- 1/3 HP motor
- 14 square inch sanding surface
- Includes one sanding belt

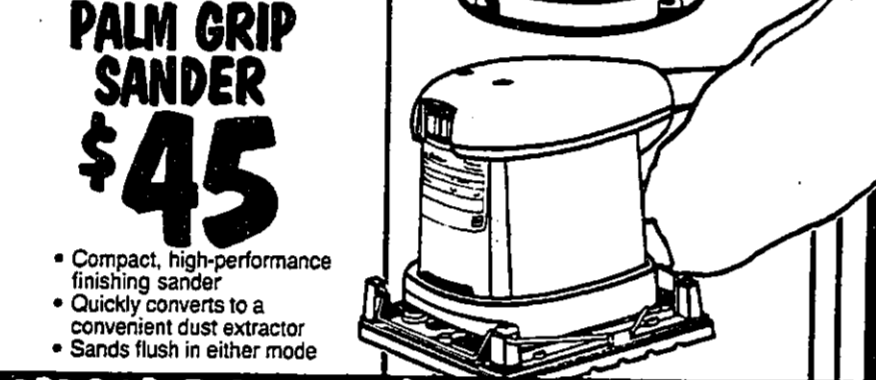

**PALM GRIP SANDER**  
**\$45**

- Compact, high-performance finishing sander
- Quickly converts to a convenient dust extractor
- Sands flush in either mode

## WE BLOW AWAY HIGH PRICES!



**DYNA-PACT AIR WRENCH**  
**\$34**

- Built in power regulator
- Torque 280 ft./lb.



**MEDIUM DUTY AIR HAMMER**  
**\$12**

- Medium air hammer with 0.401" chisel shank opening



**3/8" AIR DRILL**  
**\$22**

- 3/8" chuck
- 2,000 max RPM

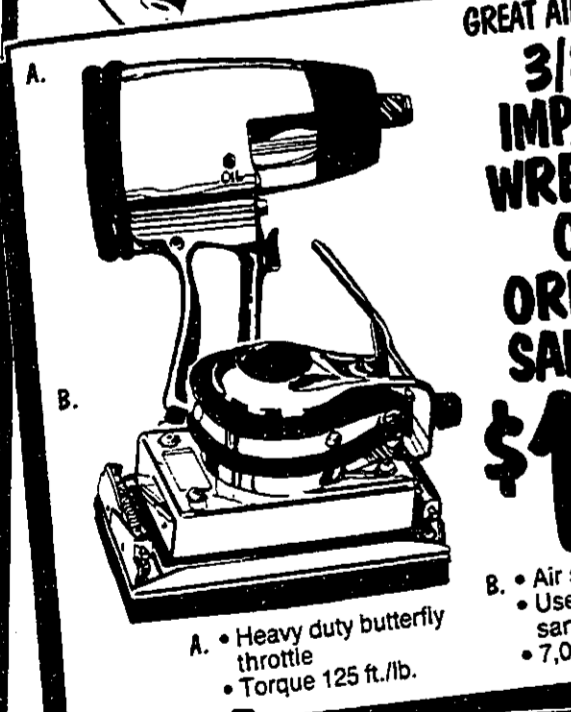

**3/8" IMPACT WRENCH OR ORBITAL SANDER**  
**\$19**

- Heavy duty butterfly throttle
- Torque 125 ft./lb.



**1/4" AIR RATCHET**  
**\$16**

- Great for taking off nuts and bolts

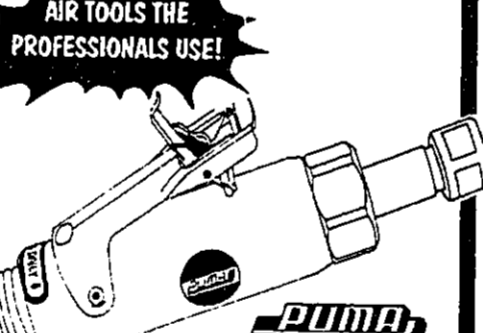

**1/4" DIE GRINDER**  
**\$19**

- Heavy duty air tool
- Maximum RPM 25,000
- Recommended air pressure—90 PSI
- Collet size—1/4"



**1/2" IMPACT WRENCH**  
**\$21**

- Rocking clutch
- Built in speed regulator
- Torque 230 ft./lb.

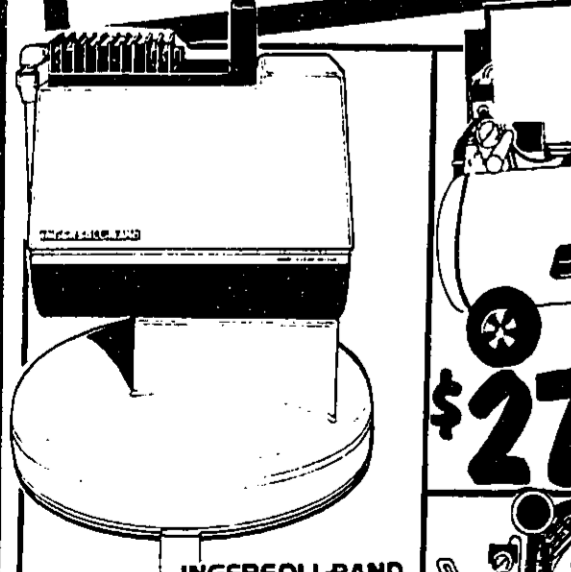

**3/4 HP ROOFERS' COMPRESSOR**  
**\$266**

- Includes reg., tank and outlet pressure gauges, 15' air hose.

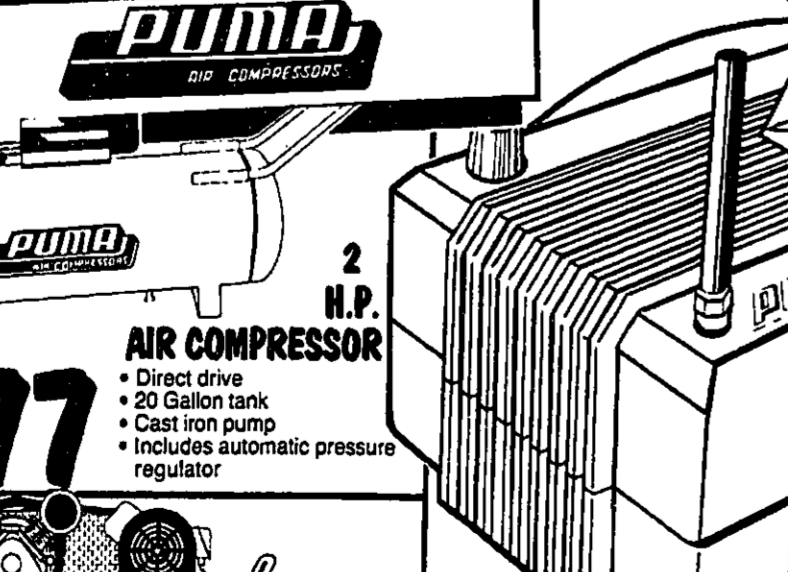

**2 H.P. AIR COMPRESSOR**  
**\$277**

- Direct drive
- 20 Gallon tank
- Cast iron pump
- Includes automatic pressure regulator



**1/2 H.P. AIR COMPRESSOR**  
**\$79**

- Completely portable.
- Oilless design is virtually maintenance-free.
- Includes air hose and tire chuck.

# WE OPENED THE DOOR TO LOWER PRICES!

## STANLEY

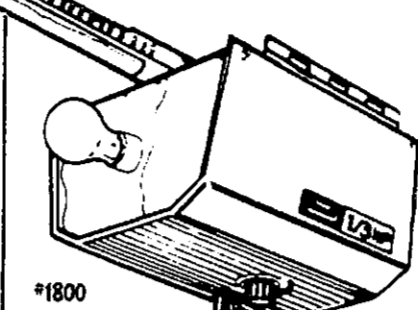

**1/3 H.P. STANDARD**  
**\$129**

- Opens doors 18" wide and 7 1/2" high.
- 4 1/2-minute light time delay.

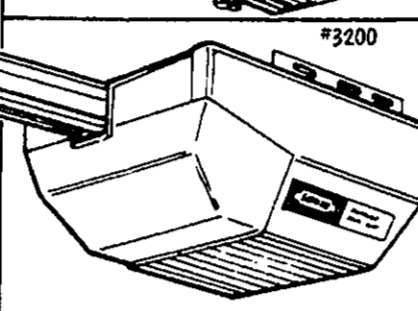

**1/2 H.P. HEAVY-DUTY**  
**\$149**

- Extra power to open heavy doors with proven steel chain and cable drive.

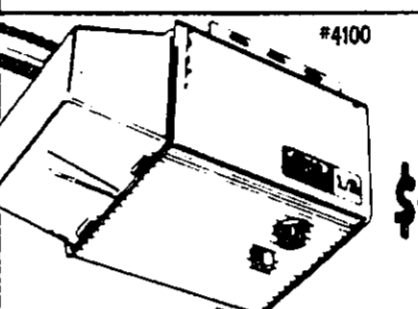

**1/3 H.P. SCREW DRIVE**  
**\$149**

- Transmitter indicator light shows battery strength.
- Instant door reverse with back-up timed reversing system.

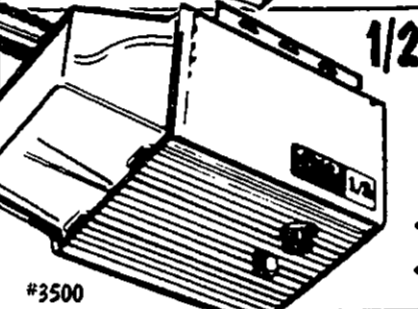

**1/2 H.P. PREMIER**  
**\$169**

- Digital transmitter with indicator light included.
- 4 1/2-minute light time delay and lamp cover.

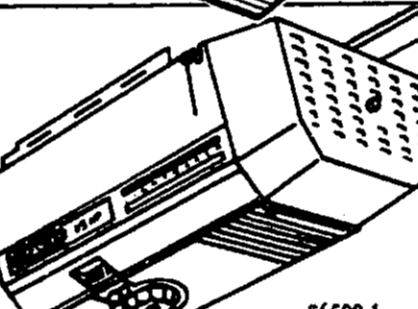

**1/2 H.P. LIGHTMAKER™**  
**\$179**

- Opens heavy doors.
- Controls indoor/outdoor house lights.
- One lamp module included.

**1/4 H.P. CHAIN DRIVE**  
**\$88**

- Chain drive with 1 digital transmitter.
- Automatic on/off light on open and close.
- Installation hardware included.
- Easy open and close with only one tap.

**INSTALL IT!**  
**GARAGE DOOR OPENER**  
**\$85**  
LABOR ONLY! FOR NORMAL INSTALLATION.  
and it's **GUARANTEED!**

**STEP UP PLEASE!**  
**6 FOOT WOOD STEP LADDER**  
**\$16**

- Type III household duty.
- Steel braces on bottom step.
- Pinch-proof spreader bars.
- Pail shelf.

**BRAND NAMES FOR LESS!**

### OPEN A NEW GARAGE DOOR!

**Clopay 8'x7' WOOD PANEL GARAGE DOOR**  
**\$139**

9'x7' ..... \$149  
16'x7' ..... \$309

**Clopay 8'x7' RAISED PANEL STEEL GARAGE DOOR**  
**\$175**

9'x7' ..... \$198  
16'x7' ..... \$325

PURCHASE A STEEL CLOPAY GARAGE DOOR AND RECEIVE A CHECK FOR \$10 FOR A SINGLE OR \$20 FOR A DOUBLE... USE THIS CHECK FOR PURCHASES AT BUILDERS SQUARE (FULL OR PARTIAL PAYMENT) NOT REDEEMABLE FOR CASH. LIMIT TWO PER INDIVIDUAL OR HOUSEHOLD.

### STEEL SHELVING FROM Hirsch

<b>STEEL 4-SHELF</b> <b>792</b> 12" x 36" x 71" #11D425H • Easy to assemble.	<b>HEAVY-DUTY 4-SHELF UNIT</b> <b>1286</b> 12" x 30" x 59" #11A20M • Heavy-duty back and side braces.	<b>EXTRA RIGID 5-SHELF UNIT</b> <b>2284</b> 12" x 36" x 71" #11D425H • The greatest rigidity ever offered in household shelving.	<b>STORAGE TOWER 7-SHELF</b> <b>1996</b> 12" x 48" x 71" #11Z10M • Perfect for laundry areas. • Height of tower is adjustable. • Can be used for a width of 18" or 12". • Heavy duty braces for stability.
5-SHELF 12" x 36" x 71" ..... 13.33 6-SHELF 12" x 30" x 59" ..... 18.96	5-SHELF 12" x 30" x 59" ..... 18.21 6-SHELF 12" x 30" x 59" ..... 21.58	5-SHELF 16" x 36" x 71" ..... 26.87 6-SHELF 12" x 30" x 59" ..... 27.93	

**TWO SHELF Z-BRACKETS**  
**69¢ EACH**

- #SB-3
- Made from rust-free galvanized steel.
- Holds shelves up to 12" wide.
- Ribbed construction for added strength.

**8 FOOT GARAGE & TOOL ORGANIZER**  
**496**

**3 FOOT MIGHTY MACK TOOL RACK**  
**296**

HANGING SHELF SUPPORT... 2.46



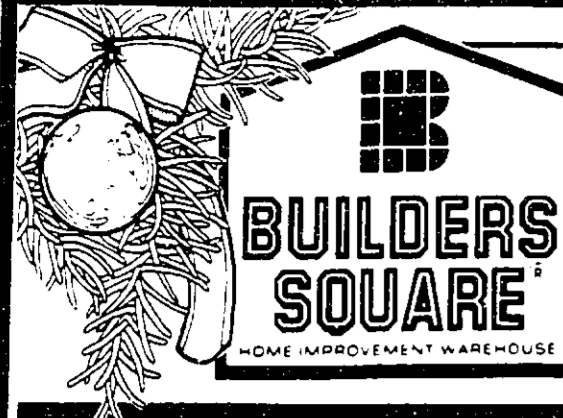

**DON'T PAY FURNITURE STORE PRICES! SAVE!**

**PRE-FINISHED FURNITURE**

**ENTERTAINMENT CENTER** #23348  
**\$34**

- Organize and display your TV, VCR or audio components.
- Extra storage behind double-swing doors.
- Styled in rich "walnut" wood tones.
- Rugged solid-core construction.
- Ready for easy assembly.

**Bush LIFT TOP AUDIO CABINET** #A641  
**\$89**

- Handsome library oak finish.
- Safety tempered glass door.
- Two adjustable interior shelves.
- Dual wheel casters.
- Ready to assemble.

**VIDEO ENTERTAINMENT CENTER** #Y362  
**\$99**

- Handsome library oak finish.
- Hidden dual wheel casters.
- 44-1/2" H x 28-1/4" W x 17-3/4" D
- Ready to assemble.

**DELUXE COMPUTER CENTER** #67319  
**\$89**

- Adjustable shelves throughout.
- 51" H x 49" W x 23-5/8" D
- Printer paper feed slot.
- Timberland finish.

**HOME ENTERTAINMENT CENTER** #67419  
**\$89**

- Extra-deep shelves.
- 65" H x 49" W x 15-5/8" D
- Timberland finish.
- Closed storage area with hinged door.
- Ready to assemble.

**ROYAL CREATIONS UTILITY CART** #72725  
**\$59**

- Perfect for TV/VCR, microwave, or other small appliances.
- Plenty of storage space for tapes or cook books and accessories.

**OPEN WALL UNIT** #250-510  
**\$79**

- Durable stain-resistant oak finish surface.
- Sturdy wood-product construction - back panel finished inside.
- Easy screw-together assembly with concealed fasteners.
- Adjustable library-depth shelves.
- 29-3/4" W x 16-1/4" D x 7-1/2" H.

**WARDROBE ARMOIRE** #250-580  
**\$149**

- Durable stain-resistant oak finish surface.
- Embossed raised-panel door styling.
- Brass-finish door pulls.
- Sturdy wood-product construction.
- Easy screw-together assembly with concealed fasteners.

**FULLY ASSEMBLED AND READY TO FINISH!**

**2-DRAWER NIGHTSTAND** #1412  
**\$47**

- 22" H x 18" W x 15" D.

**BLANKET CHEST** #1420  
**\$69**

- Pine
- 20" H x 38" W x 18" D.

**6-DRAWER LINGERIE CHEST** #1476  
**\$89**

- Ready to finish pine.
- 54" H x 18" W x 15" D.
- Completely assembled.
- Colonial style.

**4-DRAWER COLONIAL DESK** #1444  
**\$99**

- Pine
- 30" H x 43" W x 18" D.

**5-DRAWER CHEST** #1415  
**\$129**

- Pine
- 46" H x 32" W x 18" D.

**2-DOOR 2-DRAWER CHEST** #1422  
**\$129**

- Pine
- 46" H x 32" W x 18" D.

**6-DRAWER DOUBLE DRESSER** #1416  
**\$139**

- Ready to finish pine
- 30" H x 54" W x 18" D
- Fully assembled

**WARDROBE CHEST** #1447  
**\$144**

- Pine
- 46" H x 32" W x 18" D

**YOUR CHRISTMAS "FAN-TASY" THE LOWEST PRICES-GUARANTEED!**

**QUALITY CEILING FANS FOR LESS!**

**48-INCH SUMMER BREEZE** #25572 or #25606  
**\$59**

- Available in brass, antique brass, and antique white.

**52-INCH HANGING STYLE BIARRITZ** #25572 or #25606  
**\$69**

- Designed exclusively for Builders Square by Hunter, a name you can trust.
- This fan has 3-speed control, fully reversible motor and real wood blades.
- Antique brass, polished brass, or white brass.

**52-INCH LOW PROFILE BIARRITZ** #25572 or #25606  
**\$73**

- AVAILABLE IN ANTIQUE OR POLISHED BRASS WITH REAL WOOD BLADES!
- Special flush mount designed for low ceilings.

**42-INCH NEWPORT** #25572 or #25606  
**\$23**

- 3-speed pull chain operation.
- Heavy duty reversible motor.
- Light-kit adaptable.
- Available in antique or polished brass.

**52-INCH ORIGINAL** #25572 or #25606  
**\$134**

- White or Brown
- Elegant yet, energy-saving ceiling fan.
- Electrically reversible, pre-balanced and pre-assembled blades.
- Cast-iron main bearing and super-efficient motor mean stronger, quieter output.
- Easy to install.

**36-INCH WOOD - 4 BLADE** #Y36R-4W  
**\$15**

- 3 speed fan.
- Available in white or brown.

**52-INCH POLISHED OR ANTIQUE BRASS** #Y52-4W  
**\$27**

- Traditional style with ball hanger system.
- 3-speed pull chain operation.

**INSTALL IT! CEILING FANS \$40**

LABOR ONLY FOR NORMAL INSTALLATION and it's **GUARANTEED!**

**BEAUTIFUL TIFFANY LAMPS!**

**14-INCH ICE GRAY or PEARL** #150  
**\$29**

YOUR CHOICE!

- Hand-crafted leaded glass fixture-made in U.S.A.
- Porcelain light socket.
- 11" high.

**16-INCH** #163  
**\$49**

- BEIGE OR BEIGE AND COFFEE
- Accent your home with these colorful tiffany lamps

**18-INCH** #165  
**\$49**

- ICE AND COFFEE
- Handmade leaded glass fixtures

**16-INCH** #183  
**\$59**

- BEIGE AND COFFEE
- Accent your home with these colorful tiffany lamps

**SWING ARM LAMP** #896  
**\$896**

AVAILABLE IN ASSORTED COLORS!

- Spring balance movement makes this handy lamp anywhere.
- Clips on with plastic clamp and extends up to 34" high.
- Assorted colors: ivory, white, brown, and black.

GREAT FOR DESK OR WORK AREAS!

USES UP TO 100 WATT BULB!

**BRINKMANN QUALITY!**

**MICRO-MAX 2 FLASHLIGHT** #827-0550  
**793**

- 2AAA batteries included.
- Pocket clip included.
- Spot to flood adjustable beam.
- Limited lifetime warranty.

OUR LOW PRICE LESS MFERS REBATE **\$4**

YOUR FINAL COST **393**

LIMIT ONE REBATE PER HOUSEHOLD

**WEATHERPROOF LANTERN** #827-0550  
**467**

WHILE QUANTITIES LAST!

**9 IN 1 TROUBLESHOOTER** #800-1529-0  
**1286**

WHILE QUANTITIES LAST!

- Powerful spotlight is 3 times brighter than average flashlight.
- Soft fluorescent light illuminates wide area.
- Flashing light.

**BLACKMAX MINI FLASHLIGHT** #800-1040-0  
**994**

- Machined aircraft aluminum.
- Up to 80 times brighter than ordinary penlights.
- Spot to flood adjustable beam.
- Waterproof and shockproof.

**QUICKLITE LANTERN** #840-0200-0  
**1797**

WHILE QUANTITIES LAST!

**BUTANE CANISTER** #840-0200-0  
**193**

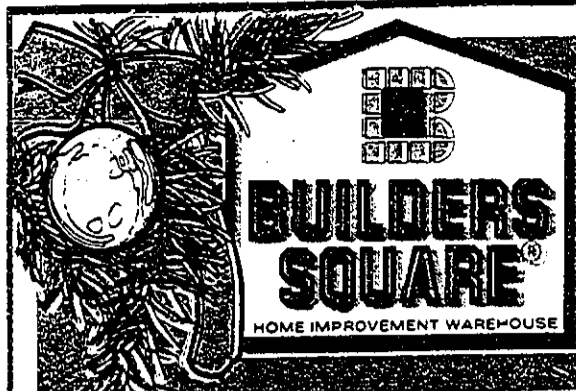

# FRESH CUT CHRISTMAS TREES!

**GIFT CERTIFICATES**  
 BUILDERS SQUARE  
 GIFT CERTIFICATES  
 ARE AVAILABLE  
 NOW



**PLANTATION DOUGLAS FIR**  
 5-6 FT. **1896**

6-7 FT. **2696**

• Douglas fir trees are the soft needled, full, lush green trees that are everyone's favorite tree for Christmas.  
 • We will custom flock the tree of your choice for a minimal charge.

**• BIGGEST SELECTION!**  
**• LOWEST PRICES!**

**PLANTATION BALSAM**  
 5-6 FT. **1877**  
 6-7 FT. **1988** 7-8 FT. **2499** 8-9 FT. **2944**

**SCOTCH PINE**  
 5 1/2 - 7 FT. **1288**

**4"-23" SPAN HEAVY DUTY TREE STAND**  
**497**



## TRIM-A-TREE WHILE QUANTITIES LAST!

<p><b>1000 SILVER ICICLES</b>  <b>20¢</b></p>	<p><b>3 PIECE CANDLE HOLDER</b>  <b>49¢</b></p>	<p><b>17" RED STOCKING</b>  <b>166</b>  <small>• Red embossed nonwoven stocking      • Printed in full color with assorted designs.</small></p>	<p><b>5 POINT TINSEL 11 LIGHT</b>  <b>244</b></p>	<p><b>SHINY GLASS</b>  <b>249</b>      Assorted Colors</p>
<p><b>BANDED GARLAND</b>  <b>297</b>      Assorted Colors</p>	<p><b>HURRICANE LANTERN</b>  <b>498</b>  <small>• Hurricane lamp with flicker bulb.</small></p>	<p><b>50 MINIATURE STRING-A-LONG</b>      OUR LOW PRICE LESS MFG. REBATE YOUR FINAL COST <b>3.88</b>  <small>• Flash or steady burning.      • Plugs at both ends.      • Includes two spare bulbs.</small></p>	<p><b>100 MINIATURE STRING-A-LONG</b>      OUR LOW PRICE LESS MFG. REBATE YOUR FINAL COST <b>6.97</b>  <small>• Features plugs at both ends.      • Steady burning or 2-way flashing.</small></p>	<p><b>140 MARQUEE SET</b>  <b>1596</b>  <small>• U.L. listed.      • Indoor/outdoor use.      • Full range speed control.      • Fully assembled.      • 63' of lights in motion.</small></p>