

50¢
THURSDAY
 June 16, 1988

Volume 33
 Number 8
 Four Sections
 plus Supplements

© 1988 Super-Living Publications. All Rights Reserved.

the NOVI NEWS

also serving Wixom and Walled Lake

Living AREA KIDS TELL WHY THEY LOVE THEIR DADS/1C

Sports THREE NOVI STARS EARN ALL-AREA HONORS/1D

Opinions CITY SHOULD SET WATER CONSERVATION LEAD/18A

City considers sprinkling ban

By PHIL GINOTTI
 staff writer

Novi officials say they may soon have to ban grass sprinkling in the city because of near-drought conditions and rapidly decreasing water pressure.

Novi City Manager Edward Kriewall and Department of Public Works Superintendent Bruce Jerome said Tuesday that the city is faced with low pressure and

there's little relief in sight. Kriewall and Jerome had a meeting Tuesday.

"We're getting pressure complaints for the first time," Kriewall said. "We're taking some steps, but unless it lets up, we're looking at banning sprinkling within a week or so."

Novi currently receives its water supply from the City of Detroit. Detroit supplies water to approximately 4,000 homes and businesses

in the city, servicing over 19,000 residents.

High demands for Detroit water in communities throughout southeastern Michigan have caused low pressure on the water coming into Novi, Jerome said.

"We called them on it and basically got a response that they were sending all they could," Jerome said.

Jerome is advising residents to follow the city's odd-even watering

system, which they put into effect last week. That voluntary system calls for residents with odd-numbered addresses to water their lawns on odd-numbered days and residents with even-numbered addresses to water on even-numbered days. He is also recommending that residents water late at night or in the early morning hours to both conserve water and eliminate non-peak hour usage.

Continued on 9

Dry Spell

Rainfall in Michigan comparatively low this year

* Through first week of June

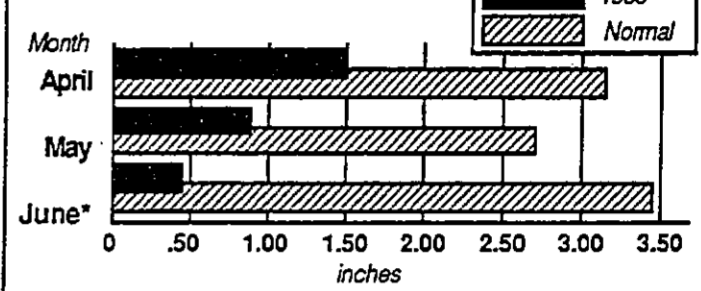

Source: State Climatologist's office

Drought worries citizens

The Oakland County Cooperative Extension Service is already being "inundated" with callers after what weather officials are calling the third driest May in history.

The dry season, and even drier start to June, has spurred several local communities, including Novi, to enact voluntary water conservation programs. Novi is currently considering a lawn sprinkling ban.

Rainfall monitoring stations at Detroit Metropolitan Airport registered less than an inch of rain during May. The 30-year average for May is usually 2.7 inches, according to Agriculture Department Analyst Anne Ordiway.

"What it means is that we are off to a very dry start to the season," she said.

Rainfall monitoring stations in Novi and Wixom registered slightly higher amounts of rainfall during May and early June, but were still far below normal levels.

Cooperative Extension Service Master Gardener Irene Pawlak said her office has been busy answering requests about a wide variety of tree and garden problems.

The biggest concern is with lawns and garden plants, she said.

Pawlak said residents should use follow several guidelines when watering their lawns in the "drought conditions" with a limited amount of water:

Continued on 9



Novi News/JOHN GALLOWAY

On their way

Some 311 seniors — the largest graduating class in the history of Novi High School — were sent on their way into the world of work or higher education during commencement exercises last Sun-

day. Bubbling over with enthusiasm in the picture above are Brenda Thal (left) and Traci Marshall. For more graduation pictures see Page 5A.

'All-Night Party' receives top grades from graduates

By BRENDA BONZHEIM
 staff writer

Fantastic times were had by all Sunday night at Novi High School, when the Class of '88 bid farewell to its high school days and welcomed in a new tradition — the first All-Night-Senior Party.

Just ask the students — approximately 185 of them attended the gala affair. Better yet, ask the parents — they had just as much fun as the students did.

Beverly Gilbert, one of the party organizers, described the event as a terrific evening that couldn't have turned out any better than it did.

"We had students coming up to us and saying 'thank-you, this is great.' When they come up to you and give you a hug in the hallway, what more could you ask for?" she asked.

"We didn't have any problems at

all. Other schools had warned us about some we might encounter, but nothing of the kind happened."

Dozens of parents volunteered their time to work on games, prepare food and monitor the action.

"Everybody put forth 100 percent and all the parents should be commended for their work. It was well worth the effort," Gilbert added. "Once the parents got there, most of them didn't want to leave."

Now, back to details about the party. . . rumor has it that one Novi graduate spent a portion of the evening searching for her belly button — the work of a crafty hypnotist, who chose four Novi students to cast under his mystical powers. He told her she wouldn't know where her belly button was and sure enough, his prediction came true.

Much to the glee and amusement of her fellow classmates, she sear-

ched the crowd for it and was even asked to offer a description of the missing belly button.

Another student who underwent hypnosis played a guitar and sang "Born in the USA" whenever the hypnotist uttered the word "freedom."

"You could have heard a pin drop when the hypnotist was on stage — the students were enthralled," Gilbert remarked.

Other entertainment included a magician, a face painter, a clown, a palm reader, a disc jockey, a video dance, a casino, midway games and impressive door prizes such as a hot air balloon ride, a limousine ride, dinner for two at Chez Raphael, a compact disc player and cameras. All door prizes were donated by local merchants.

Continued on 10

Byers back in, Thornton wins

By BRENDA BONZHEIM
 staff writer

The race is over and the results are in.

Incumbent Raymond Byers and newcomer Sandra Thornton were elected to serve four-year terms on the Novi Board of Education in Monday's annual school election.

Byers was the highest vote-getter with 482, while Thornton received an impressive 423 votes. They were among five candidates running for election to the school board.

The two seats on the school board became available as terms for Byers and board member Norman Miller expire on June 30. Miller chose not to seek re-election.

Unofficial tallies indicate that candidate John Streit came in third with 362 votes, while Craig Foreback received 271 votes and Jon Dostal received 101 votes.

"I'm very proud that the citizens have seen fit to choose me to serve a four-year term and I'm looking for-

ward to serving the community," Byers remarked in a phone interview Tuesday morning.

"I've even managed to get all my signs down already," he jokingly added.

Byers currently serves as board secretary and has served on the school board since August 1985, when he was appointed to fill the unexpired term of Ronald Milam, who resigned. Byers then defeated John Balagna in the June 1986 school election, winning a two-year term on the board. After Monday's election victory, he will continue to serve on the school board until 1992.

Thornton also expressed pleasure about being elected to the school board.

"I'm very excited about the opportunity to share my knowledge and insights with the children and the community as a newly-elected trustee to the school board," Thornton said in a phone interview Tuesday afternoon.

Continued on 18



RAYMOND BYERS



SANDRA THORNTON

City to proceed on Landing site

By PHIL GINOTTI
 staff writer

The City of Novi has won half its battle over condemnation of property near the shores of Walled Lake.

As a result, the city will get to take a small lakefront lot and turn it over to developers of the proposed Shoreline project. A jury will determine a fair price for the land at a future date.

The city sought condemnation of several lots near the western border of a 12-acre-site which is to contain Jay Eldridge's "Landing" project on the southern shores of Walled Lake. One of the lots is approximately 20 feet wide, allowing limited lake access for between 15 and 20 families.

The Landing site is located near the Thirteen Mile/Novi Road intersection.

Since a date for further appeal passed last week, the force of an Oakland County Circuit Court order okaying the taking of the property will now go into effect, according to Assistant City Attorney Dennis Watson.

In a condemnation case, a unit of government must prove a need (necessity) and then later have the courts determine a fair price for

Watson:
 'What it means is that the City of Novi has title vested in it.'

the land if the two parties are unable to reach agreement.

Oakland County Circuit Court Judge David Breck ruled in favor of the city in March. Residents filed an appeal to the Michigan Court of Appeals but the city prevailed.

"What it means is that the City of Novi has title vested in it," said Watson. "The amount of compensation will be determined further down the line with the jury trial."

Eldridge plans to build a public/private development on the site containing restaurants, banquet facilities, retail space, and a 100- to 110-room inn. The development would also include a city meeting facility, a beachfront boardwalk and a dock servicing approximately 25 boats.

Continued on 18



WOW!
126
Garage Sales
In The
Green Sheet
Get Results
(313) 348-3022

inside

EDITORIALS	16A
IN SHAPE	6D
LETTERS	17A
LIVING	1C
NOVI BRIEFS	4A
NOVI HIGHLIGHT	2C
PHIL GINOTTI	19A
PHIL JEROME	18A
POLICE BLOTTER	4A
SPORTS	1D
WANT ADS	3B

EDITORIAL 349-1700
 ADVERTISING 349-1700
 CLASSIFIEDS 348-3024
 DELIVERY 349-3627

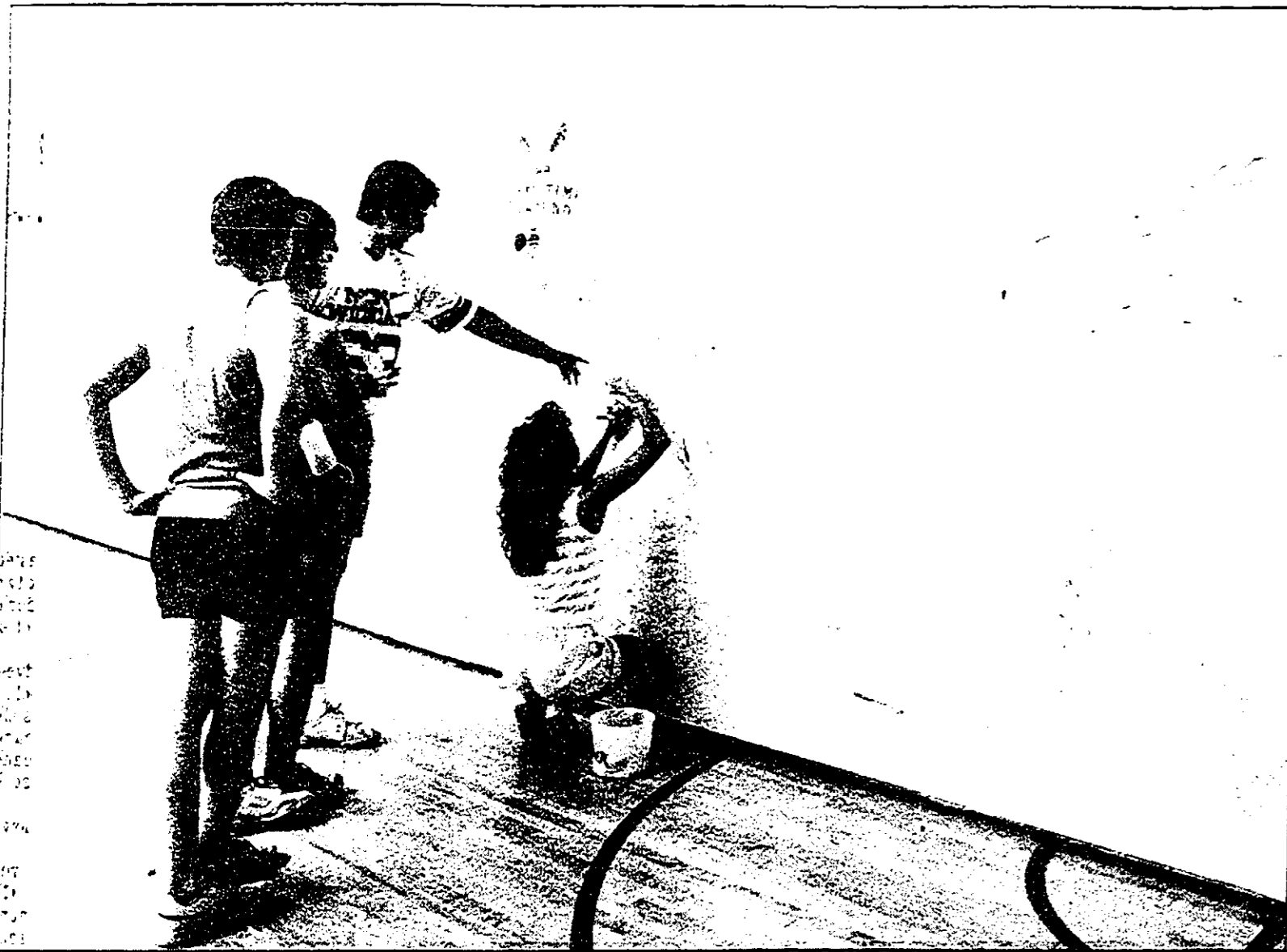

Graduates sign in on a giant poster at the first-ever All-Night Graduation Party

'All-Night' party gets high grades

Continued from Page 1
The theme of the party was "The Last Time Around '88." It began at 8:30 p.m. and didn't wind down until around 4 a.m.
During the students' early morning breakfast, they were treated to a videotape presentation featuring highlights of their high school careers through commencement exercises.

"Someone started passing out napkins as the videotape played because it was kind of tearful," Gilbert commented.
Each student attending the party can expect to receive a copy of the videotape, she added.
And what's next for the party organizers? Well, some of them admit it's never too early to begin work on next year's Senior-All-Night Party.



Kevin Novak had the ultimate 'blind date' at the party

Don't miss this...
Brainer's Birthday Sale
30% OFF
All Nursery Stock
• Annuals
• Hanging Baskets
• Rose Bushes Thru June 19

BRAINER'S GREENHOUSE
51701 Grand River
1 1/2 Miles West Of Wixom Rd. 349-9070



Magician Butch Shoem provided some of the entertainment

High Powered Savings For DADS & GRADS from SWIFT

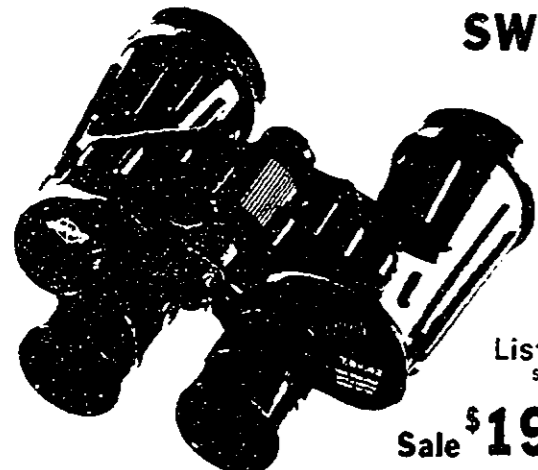

List Price \$270
Sale \$199.95

75A OSPREY (Armored) 5x2.5" 136" F1-29.5" R.L.E. 52"
The choice optical systems are protected from shock by a rubber coating - and fingerprints are prevented, making a case unnecessary. It comes with a case is desired, a beautiful blue padded cloth case with black leather-like trim is available. Computerized optics utilizing premium optical glass - plus the new B&W 2 prism material - give the binocular the eyes of a hawk. Featuring strap, clear close focusing down to 16 feet, the shock resistant binocular with its 19mm eyepieces, was designed for the outdoors enthusiast. Sale Ends June 25, 1988

NORTHVILLE CAMERA AND FRAMING SHOP
105 E. Main Northville
OPEN Mon.-Thurs. & Sat. 9-6
Fri. 9-7 Sun. 12-5
349-0105

What a Mug!

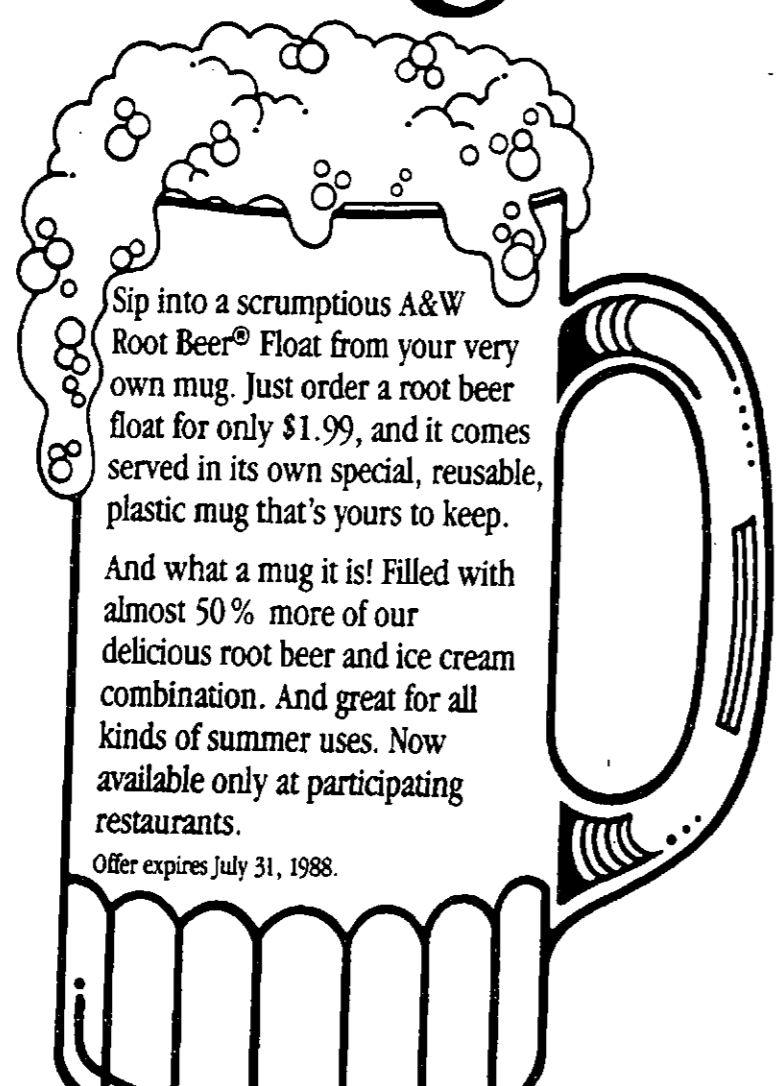

Sip into a scrumptious A&W Root Beer® Float from your very own mug. Just order a root beer float for only \$1.99, and it comes served in its own special, reusable, plastic mug that's yours to keep.

And what a mug it is! Filled with almost 50% more of our delicious root beer and ice cream combination. And great for all kinds of summer uses. Now available only at participating restaurants.
Offer expires July 31, 1988.



Dearborn: Just Outside Fairlane Mall
Sterling Heights: Inside Lakeside Mall
Dearborn Heights: 26253 Ford Rd.
Southfield: 29285 Southfield Rd.
Troy: Just Outside Oakland Mall
Garden City: 32227 Ford Rd.
Novi: Inside 12 Oaks Mall
Rochester Hills: 3178 S. Rochester St.
Rochester: 3178 S. Rochester St.
Taylor: 27293 Eureka Rd.



Fathers Day is Sunday

...Yeah! Lapham's has **Arrow**™ Shirts for Dad!!! If we buy two **Arrow**™ Dress Shirts, we get a tie at **HALF-PRICE!!!**

The staff at Lapham's even helps us put all the right colors together.
...That's right! they have their entire selection of **COTTON SWEATERS** on Special, 20% OFF!
...Hey, don't worry about giftwrapping. Lapham's will do it for us!

Custom Tailoring for Men & Women
Regardless where purchased.

Lapham's
Men's Shop

120 E. Main Northville
349-3677
Mon. Sat. 9-6
Th. & Fri. 10-6 p.m.
Sale Ends June 18

Home of the Athlete's Business Suit



Fourth-grader Heather Huff wants to be the first person to land on Mars

Future astronaut Student enjoys space camp

By BRENDA BONZHEIM staff writer
Heather Huff wants to be the first person to land on Mars.
That's quite a dream for a 10-year-old girl, but one look at her cheery, confident smile makes it seem possible. Just ask her about outer space or any of the planets and she'll happily blurt out a wealth of information.
Huff's interest in the galaxies was peaked after her fourth grade teacher at Novi Meadows asked her to write a report about outer space. After researching the topic, Huff said she wanted to learn more.
And she did. The youngster's five-year involvement with the Michigan Metro Girl Scouts gave her the chance to gain hands-on experience in space-related activities when she was chosen to participate in a NASA-sponsored Space Camp in Huntsville, Alabama.
Forty other girls from throughout the Detroit area traveled to Alabama as part of the Girl Scout's Wider Opportunity Program, which offers scouts opportunities to travel to various destinations to pursue their interests.
Before boarding the bus heading south, Huff attended interviews and informational meetings about the space program. To help fund the trip, she sold candy bars within the neighborhood and saved money she had earned watching the neighbor's dog.
"She worked hard toward paying for the trip - it wasn't just handed to her," her mother Lynne explained. Months passed before Huff even learned that she had been chosen to attend the space camp. As soon as the mail carrier delivered her letter of acceptance, Huff said she could hardly believe it.
"I was really surprised and excited," she remembered.
Once in Huntsville, Huff's excitement grew. The Alabama space center offers students in fifth through 12th grades the opportunity to try actual astronaut training equipment. Huff attended classes to learn about space and aerodynamics as well as taking part in experiments and exercises.
Those exercises included eating freeze-dried space food such as chicken, peas, strawberries and ice cream.
"The ice cream was the best," Huff reported.
Her favorite episode during space camp, however, was a mock mission, when she sat at the controls of a spaceship and gave directions for launching and landing the craft.
"There were cameras inside the spaceship so we could see what was going on," Huff remarked. "It lasted for a half hour and we had to fix two problems - a computer shutdown and a light failure - it was a lot of fun."
Although the space camp adventure is over, Huff has a scrapbook, a space suit and dozens of trinkets she swapped with other girls at the camp to remember it by. She also came home with a renewed interest in space and science.
"I want to be an astronaut now," she says with delight.
Meanwhile, Huff keeps busy with activities sponsored by the Girl Scouts. For example, once a month she visits her "adopted grandmother," Rosalee, at a local nursing home. Huff also enjoys oil painting, drawing, stenciling, cooking, bicycling, climbing, launching miniature rockets, telling jokes, the clarinet and playing with her dog, Dixie, and several other animals at her aunt's country farm.
Heather is the daughter of Bill and Lynne Huff of West LeBois in Novi. She also has a sister, Dana.

NOTICE

IN ACCORDANCE WITH THE REQUIREMENTS OF THE SAFE DRINKING WATER ACT AMENDMENTS OF 1986, NOVI MEADOWS AS YOUR WATER SUPPLIER IS PROVIDING THIS INFORMATION TO HELP EDUCATE YOU ON THE POSSIBILITY OF LEAD IN YOUR DRINKING WATER.
Since 1976, lead consumption by humans has been reduced significantly. We, as your water supplier, are cooperating in the effort to further reduce lead in human consumption. Your drinking water MEETS the lead standard of 0.05 parts per million as required by the U.S. Environmental Protection Agency. Your system monitors and tests the lead content of the system's water to determine the levels of lead delivered to the service connections at your homesite.
However, lead piping and lead solder used in household plumbing may affect domestic water supplies. Lead content can be reduced by replacing lead pipe or connections with lead-free materials. Visual inspections by homeowners or a plumber can generally reveal the presence of lead in the plumbing system. Because lead is a soft, gray metal, pipes made of lead will scratch easily and the scratches will be shiny. People who may have concerns about lead from their household plumbing may want to have their own water tested by a reputable private laboratory as it comes from the tap.
EPA provides the following information:
The United States Environmental Protection Agency (EPA) sets drinking water standards and has determined that lead is a health concern at certain levels of exposure. There is currently a standard of 0.05 parts per million (ppm). Based on new health information EPA is likely to lower this standard significantly.
Part of the purpose of this notice is to inform you of the potential adverse health effects of lead. This is being done even though your water may not be in violation of the current standard.
EPA and others are concerned about lead in drinking water. Too much lead in the human body can cause serious damage to the brain, kidneys, nervous system, and red blood cells. The greatest risk, even with short-term exposure, is to young children and pregnant women.
Lead levels in your drinking water are likely to be highest:
- If your home or water system has lead pipes, and
- If your home has copper pipes with lead solder, and
- If the home is less than five years old, or
- If you have soft or acidic water, or
- If water sits in the pipes for several hours.
Novi Meadows is advising you that you can take a number of steps to mitigate the problems of lead contamination in drinking water, including using only water from the cold-water tap for cooking or drinking, running the tap for a few minutes to flush the system before using water for cooking or drinking, or replacing lead pipes. Visual inspection can often reveal lead pipes or solder, though testing is the only way to be certain if your water is safe.
It is our concern that our residents are not misled by commercial groups offering expensive services to solve a possible problem which can be handled by common sense. We want you to know the facts.
For additional information the U.S. EPA has a toll free hotline dedicated to this subject - 1-800-426-4791 - and they have also prepared a booklet on this issue. If you have additional questions contact your local Health Department at 856-1280, or your Community Manager at 348-8898, between 9:00 p.m. and 5:00 p.m. Monday through Friday.
(6/16/88 NN)

Laurel
FURNITURE
OAK

• Table 42" Round • Two 12" Leaves • 4 Bow Back Side Chairs
Reg. \$599.99
SALE \$399.99

OPEN DAILY 9:30-6:00
584 W. Ann Arbor Tr.
THURS.-FRI. 9:30-5:00
Plymouth • 453-4700

WET BASEMENT?

Hydroflo
SYSTEM
The Waterproofing Alternative

1 800 782-8070
For free on site inspection

UNCONDITIONAL LIFETIME WARRANTY!

Hydroflo System Warrants your Basement against leakage for the life of the Structure, Regardless of Ownership.

Huron Valley Hospital's Physicians Referral Program.

Because some things just can't wait.



One of the most important parts of good health is a regular checkup, for everyone, not just the kids. If it's been "too long" since someone in your family has seen a doctor, no matter the reason, you can do something now. Maybe just a little reminder and a gentle nudge are all it will take. But perhaps some help finding the right doctor will be necessary. If that's the case, let Huron Valley Hospital's Physicians Referral Program do work for your family.
As close as the phone, our health care professionals are ready to listen and help. They understand all the reasons for needing a referral - new in town; doctor has retired; never had a doctor; just not comfortable with this doctor. Whatever the reason, whatever the need, the Huron Valley Hospital's Physicians Referral Program can help your family find the right doctors.
Ask us about office hours and locations. Give us your preference for male or female doctors. Do you want a Family Practice physician? Do you need a specialist? Huron Valley Hospital has more than 300 physicians on staff. Our doctors are located here in the community and throughout Oakland, Livingston and Wayne Counties. We'll find just the right doctor for you. And when we do, you'll have the comfort of knowing that if hospitalization is ever necessary, you'll stay in the neighborhood, because your family and your doctor are all part of the same Huron Valley Hospital family.
Please phone 360-3300, extension 3450, weekdays between 9:00 a.m. and 5:00 p.m.

HURON VALLEY HOSPITAL

1601 East Commerce Road • Milford, MI 48042 • (313) 360-3300
A Member of The Detroit Medical Center • 1987 HVH 126-5458

Election losers, winners

Continued from Page 1

She characterized this year's election as an amiable one because some of the candidates shared a lot of the same concerns and ideas and felt comfortable discussing them among themselves.

"This was a real fun campaign," she stated.

Thornton previously sought election to the school board in 1986, when eight candidates entered the race. She is an instructor of public speaking at Schoolcraft College and has been a resident of Novi for 11 years. She has two sons enrolled in the Novi school system.

Thornton was the favorite in Precinct One (Novi Middle School), where she was named on 92 ballots. Close behind was Byers with 78 votes. Streit obtained 60. Foreback had 62 and Dostal was named on 14 ballots.

In Precinct Two (Orchard Hills), Byers lead the pack with 149 votes. Thornton was second with 131, and was followed by Streit (102), Foreback (82) and Dostal (52).

Byers also captured a major portion of votes in Precinct Three (Village Oaks) where he was named on 242 ballots. Thornton, on the other hand, received 199 votes and was followed closely by Streit, who was named on 194 ballots. Foreback received 153 votes and Dostal captured 34 votes.

Absentee voter ballots totaled 13 for Byers, seven for Thornton, six for Streit, four for Foreback and one for Dostal.

City may get lake property

Continued from Page 1

Eldridge gets most of the land from the city at low cost in exchange for some shared uses and a high degree of control over the project.

Watson said the city now will be allowed to dispose of the land as it sees fit, despite no purchase price being determined.

Residents and landowners in the area are still unhappy about the deal.

"You can take everything I've ever learned about this country and throw it down the tubes," landowner Paul Perry said. "They've taken a piece of private property and turned it over to a private entity. They're making it very easy for them."

"They are in violation my constitutional rights and everyone else's out there," he added.

Though city officials have not released the amount of money spent on acquiring the remaining parcels of land through condemnation, it is believed they offered \$400 to 17 affected homeowners.

Watson said the condemnation was justified because of the public benefits and the effect the development could have on the northern Novi area.

"Clearly, there are benefits to the community with the boardwalk and community room," Watson said.

"Plus you have the overall effect of the development. It should have a positive effect on the property in that area."

Watson said he was unsure when a jury trial on the property's value might begin.

Don't be a heartbreaker

Reduce if overweight.

American Heart Association
WORKING FOR YOUR LIFE

Go to bat against

Birth Defects

Support the
March of Dimes



Make DAD Feel Great...

Thank him for the good times-June 19

HIGHLAND LAKES SHOPPING CENTER

7 Mile at Northville Rd.

A Country Coop

From the Heart
Not Just A Country Store!

New...
THE MAIL ROOM

• Packaging • Gift Wrapping
• Custom Gift Baskets • We Ship Anywhere

43249 W. Seven Mile • Northville • 347-0266
(In Highland Lakes Shopping Center)

GORDON'S
School Office Supplies
• Art • Drafting • Computer Supplies

CROSS PENS 20% OFF **BRIEFCASES 15% OFF**

Great Dad or Grad Gift...
Silver Reels, Electronic w/Auto Correction
TYPEWRITER \$199.50 (Any Trade Reg. '2429)

348-TYPE

Father's Day Cakes.

the whole family can enjoy

Show Dad your good taste with a delicious ice cream cake. We have a dazzling array of tempting ice cream desserts just right for Father's Day. Order early for custom cakes made with his favorite flavor ice cream and choice of vanilla or chocolate cake. It's a Father's Day treat the whole family will enjoy.

BASKIN ROBBINS
42969 W. Seven Mile • Northville
(In Highland Lakes) 348-3331

Participating Merchants:
• Baskin Robbins • CMS Tanning & Toning • Decorating By Dan • Gordon's Office Supplies • From The Heart • Plaza Dance Company • New Wing Hing • Sunshine Pet Center

NEW WING HING RESTAURANT

新永興

CANTONESE • MANDARIN • SZECHUEN AMERICAN CUISINE

OPEN FATHER'S DAY

2-10 pm

Treat Dad To One Of Our Seven Sunday Specials

Dine In Or Carry-Out Service
348-1411

43171 W. Seven Mile, Northville, MI 48177 (Highland Shopping Center)

Moore's exterior House Paint Sale

SAVE \$3 OFF Per Gallon

MOORWHITE PRIMER
MOORGLAZ
MOORGLAZ
MOORGLAZ

MOORE'S FLAT EXTERIOR LATEX HOUSE PAINT
MOORGLAZ LATEX HOUSE & TRIM PAINT
MOORGLAZ LATEX HOUSE PAINT

DECORATING BY DAN
Wallpaper, Paint, Window Treatments
43157 W. 7 Mile • Northville • 348-1599

SUNSHINE PET CENTER

42951 W. 7 Mile Northville 348-8844

ALL FLEA PRODUCTS 20% OFF

ALL TETRA MIN FISH FOOD 20% OFF

A Natural Treat For Your Bird SPRAY MILLET 20% OFF

These Specials Good Thru July 15, 1988 With This Ad Only.

the **Piazza Dance Company**
Of Northville Presents...

The Magic of Dance

OWNERS
Marilyn Esper, Denise Slesiec, Gina Piazza

Don't miss this exciting variety show filled with award-winning dance routines and magical illusions. Fun for the entire family!

2 Performances: **Wednesday, June 29 7:30 p.m.** **Thursday, June 30**
in the auditorium at:
Plymouth Salem High School
(Canton Center at Joy Road)

Reserved Tickets \$5
Available At The Door Or In Advance At:
PIAZZA DANCE COMPANY
42977 W. Seven Mile Northville 348-3720

CMS TANNING & TONING CENTER, INC.

42949 W. 7 Mile (Highland Lakes Shopping Center) • Northville • 349-0907

OPEN 7 DAYS APPOINTMENTS ARE RECOMMENDED

The Newest Equipment In Passive Exercise Technology

At last an effective way to remove inches quickly and effortlessly. Designed to firm and tone your body without the hassle of sweat and pain, the EASY TONE BODY SYSTEMS gets results in a fraction of the time traditional exercise requires. The different tables focus on specific muscle groups of the body to help firm, tone and reduce inches.

At last...the alternative to "NO PAIN - NO GAIN!"

- NO CONTRACTS
- NO MEMBERSHIPS
- NO DUES

HIP TONER

Helps shed inches from waist, stomach area, and hips while stretching muscles in lower back.

Get A Good Base Tan With Our Woffle Tanning Beds

SUMMER TONING Special

20 Visits \$65.00 Now Only

Visits Must Be Completed By October 1, 1988

With This Coupon Only • Easy Toning Body Systems

SUMMER TANNING Special!

15 Visits \$45.00 Now Only

Visits Must Be Completed By October 1, 1988

With This Coupon Only • Wolff Tanning Systems

Senior Citizens... Always Receive A 20% Discount

GREEN SHEET

Sliger/Livingston East

Section B

Wednesday/Thursday - June 15/16, 1988

Century-old store back in business in Salem Village

By KAY FAHEY

Step back in time. Walk past the petunias blooming on the porch, turn the worn brass handle, and step through the weather-beaten door of The Store.

Locate at 9607 Six Mile, directly across from the township hall in the heart of Salem, The Store is a bit of local history come to life.

The building, erected on land first deeded by President Andrew Jackson in 1831, was completed in 1876. It has been used continuously ever since as a store and a gathering place for the Salem community.

Around the turn of the century, the area behind the building was used as a recreation area, according to owners Maryann and Jerry Klump. During Prohibition, the store property also housed a speakeasy, the Klumps said.

Vestiges of the original store still may be seen. "We exposed the brickwork and lathing at the back of the store to show people how it was built," reported Maryann.

The basement, built of Michigan field stone, still contains the old water cistern. The basement is now used to store paper products and returned soda cans.

The original four posts recently were re-installed on the front porch. Oak shelving and decorative work on a side wall also are original. A ceiling fan of undetermined age supplements the air conditioner. "That old fan works better than any new one," Maryann said.

The "antique" theme is even continued in the cooler, which was built by Jerry Klump from 100-year-old barn timbers. But the contents of the cooler are strictly modern. "We have nothing but ice-cold drinks. You can't buy a warm beer here," said Jerry Klump.

Aside from cold sodas and beer, the store carries wine coolers and dairy products. Snacks, candy, newspapers, canned goods, lunch



Photo by JOHN M. GALLOWAY

The Store offers all the conveniences of a modern grocery store in an historic atmosphere

Father's Day Sale

LA-Z-BOY STARTS TODAY!

Put Dad at ease for a price that's downright relaxing!

SALE \$299.00

Many styles in stock for immediate delivery.

124 N. Lafayette South Lyon 437-1590
Hours: Daily 10-9, Sun. 12-5

Tempenny's
CHERRY AND OAK FURNITURE

Fletcher & Rickard

LANDSCAPE SUPPLIES INC.

Buy One Bag Of Screened Soil Get The Second Bag FREE

With This Coupon Limit 1 bag per visit per coupon

SEVERSON'S MILL & FARM SUPPLY

56675 Shepo Road • New Hudson, Michigan 48165
Mon-Sat (313) 437-1723 Live Stock Hauling

Complete Line of Carnation Feeds In the Historical New Hudson Elevator

Tired Of Feeding Dirty Sweet Feed. Take The Jump To Severson's Mill. We Use 40 Plus Test Weight Oats, Cracked & Cleaned Corn. Get It In 10%, 12%, 14% And 16% Protein.

Fortuna Inn of South Lyon

Chinese-American Restaurant Good Quality Food is our Business

Special Menu for Dad!

Sunday, June 19, 1988

All-U-Can-Eat Children Under 10 \$3.25

Adults \$7.25 11am-3pm

Call For Reservations 437-4700
22281 Pontiac Trail, South Lyon • Brookdale Square
Mon-Thurs 11-10; Fri & Sat 11-11; Sun 11-9

GIFTS FOR THE DAD WHO HAS EVERYTHING

12 HP Tractor With 42" Mower

Retail \$2495 Sale \$1695

Model 112
• 12 hp industrial cast iron Briggs & Stratton engine
• 5 Speed transmission
• Cast iron front axle with bearings
• Heavy duty double channel welded frame
• Timed 42" mower included
• Rear bagger available
• Implement lift assist
• Lights & electric start
• Weighs 530 lbs.
• 2 Year Warranty

Jonsered

3 for the Price of 1 String & Brush Cutters

Extra Comfort Extra Tough

Impressive

1. A Grass Trimmer!
2. A Weed Cutter!
3. A Brush Saw!

Lifetime Ignition Warranty
2 Year Warranty
"The Professional Trimmer"
Starting at **\$199.95**

New Hudson Power
53535 Grand River at Haas
2 miles east of Pontiac Trail
Hours: Mon-Fri 9-6; Thurs 11-8; Sat 8-3; Sun 9-2 (313) 437-1444

Dan's Auto Repair

43151 Grand River 348-1230

Lifetime Guarantee
Brake Pads \$29.97 per wheel
Metallic Extra Most Cars

New Hudson Power

53535 Grand River at Haas
2 miles east of Pontiac Trail
Hours: Mon-Fri 9-6; Thurs 11-8; Sat 9-3 (313) 437-1444

FOR HEALTHY BABIES... build a strong foundation with good prenatal care.

March of Dimes

WINDOW SHOPPING??

We Stop Window Pains!

ALL-WEATHER SEAL CO. INC.

"Local Representatives To Service Your Needs" - FREE IN HOME ESTIMATES -

- Vinyl Siding
- Vinyl Patio Door Wall
- Porch Enclosures

1-800-621-2828

021 Houses
BRIGHTON, Horizon Hills, Brighton Schools, 3 bedroom ranch, 1 1/2 baths, full basement, walkout, 2 car garage, large beautiful landscaping, 51,700. REALTY WORLD/285-3365.

021 Houses
BRIGHTON OPEN HOUSE SUNDAY 1-5 PM 2875 INDEPENDENCE
Executive ranch on 5 rolling acres with almost 5000 sq. ft. of living space. Color and quality begin to describe the home. Only one over the 1/2 acre setting from the 24 ft. deck, 3 bedrooms, 2 1/2 baths, 2 car garage, 19' vaulted ceiling, 15' high ceilings, 15' wide crown molding, 15' wide crown molding, 15' wide crown molding.

021 Houses
HAMBURG, by owner, immaculate 8 year old bungalow. Beautiful view overlooking large pond, vinyl siding, 2 1/2 car attached garage. Family room with fireplace, tile floor, 15' x 15' tile floor, insulated, very energy efficient. Exceptionally well landscaped, back yard sprinker system, nicely landscaped, 15' wide crown molding, 15' wide crown molding, 15' wide crown molding.

024 Condominiums For Sale
HOMELAND Golden Triangle Association, 2121 1/2 S. Grand, 1470 sq. ft. 3 bedrooms, 2 1/2 baths, full basement, walkout, 2 car garage, large beautiful landscaping, 51,700. REALTY WORLD/285-3365.

025 Mobile Homes For Sale
HIGHLAND Greens, 1986 North, Highland Hills Estates, 1470 sq. ft. 3 bedrooms, 2 1/2 baths, full basement, walkout, 2 car garage, large beautiful landscaping, 51,700. REALTY WORLD/285-3365.

026 Mobile Homes For Sale
HIGHLAND Greens, 1986 North, Highland Hills Estates, 1470 sq. ft. 3 bedrooms, 2 1/2 baths, full basement, walkout, 2 car garage, large beautiful landscaping, 51,700. REALTY WORLD/285-3365.

027 Vacant Property For Sale
HOMELAND Golden Triangle Association, 2121 1/2 S. Grand, 1470 sq. ft. 3 bedrooms, 2 1/2 baths, full basement, walkout, 2 car garage, large beautiful landscaping, 51,700. REALTY WORLD/285-3365.

103-105 Rayson, Northville 349-4030
City of Northville - Large Cape Cod in heavily treed area. Unique landscaping, 2330 sq. ft. of desirable living area. Large walkout basement.

021 Houses
BRIGHTON, Beat the heat with central air and an attic fan. Spacious living room, finished basement, 2 car garage, walkout, 2 car garage, large beautiful landscaping, 51,700. REALTY WORLD/285-3365.

021 Houses
BRIGHTON, Beat the heat with central air and an attic fan. Spacious living room, finished basement, 2 car garage, walkout, 2 car garage, large beautiful landscaping, 51,700. REALTY WORLD/285-3365.

021 Houses
BRIGHTON, Beat the heat with central air and an attic fan. Spacious living room, finished basement, 2 car garage, walkout, 2 car garage, large beautiful landscaping, 51,700. REALTY WORLD/285-3365.

021 Houses
BRIGHTON, Beat the heat with central air and an attic fan. Spacious living room, finished basement, 2 car garage, walkout, 2 car garage, large beautiful landscaping, 51,700. REALTY WORLD/285-3365.

021 Houses
BRIGHTON, Beat the heat with central air and an attic fan. Spacious living room, finished basement, 2 car garage, walkout, 2 car garage, large beautiful landscaping, 51,700. REALTY WORLD/285-3365.

021 Houses
BRIGHTON, Beat the heat with central air and an attic fan. Spacious living room, finished basement, 2 car garage, walkout, 2 car garage, large beautiful landscaping, 51,700. REALTY WORLD/285-3365.

GENTRY REAL ESTATE
MLS logo, phone number, address, website information.

Adler
Super Energy Efficient Homes
Model homes, phone number, address, website information.

ROSE REALTY
2336 E. HIGHLAND ROAD
HIGHLAND, MICHIGAN 48831
Win A Bentley! Call Our Office For Details.

Bank Pre-Approved
Home Loans
Call for details, phone number, address, website information.

PARK ASSOCIATES
Bank Pre-Approved
Home Loans
Call for details, phone number, address, website information.

026 Mobile Homes For Sale
HIGHLAND Greens, 1986 North, Highland Hills Estates, 1470 sq. ft. 3 bedrooms, 2 1/2 baths, full basement, walkout, 2 car garage, large beautiful landscaping, 51,700. REALTY WORLD/285-3365.

026 Mobile Homes For Sale
HIGHLAND Greens, 1986 North, Highland Hills Estates, 1470 sq. ft. 3 bedrooms, 2 1/2 baths, full basement, walkout, 2 car garage, large beautiful landscaping, 51,700. REALTY WORLD/285-3365.

BRIGHTON
Ranches
Bi-Level
Tri-Level
Some Models 65 Day Occupancy
Model homes, phone number, address, website information.

026 Mobile Homes For Sale
HIGHLAND Greens, 1986 North, Highland Hills Estates, 1470 sq. ft. 3 bedrooms, 2 1/2 baths, full basement, walkout, 2 car garage, large beautiful landscaping, 51,700. REALTY WORLD/285-3365.

026 Mobile Homes For Sale
HIGHLAND Greens, 1986 North, Highland Hills Estates, 1470 sq. ft. 3 bedrooms, 2 1/2 baths, full basement, walkout, 2 car garage, large beautiful landscaping, 51,700. REALTY WORLD/285-3365.

026 Mobile Homes For Sale
HIGHLAND Greens, 1986 North, Highland Hills Estates, 1470 sq. ft. 3 bedrooms, 2 1/2 baths, full basement, walkout, 2 car garage, large beautiful landscaping, 51,700. REALTY WORLD/285-3365.

026 Mobile Homes For Sale
HIGHLAND Greens, 1986 North, Highland Hills Estates, 1470 sq. ft. 3 bedrooms, 2 1/2 baths, full basement, walkout, 2 car garage, large beautiful landscaping, 51,700. REALTY WORLD/285-3365.

026 Mobile Homes For Sale
HIGHLAND Greens, 1986 North, Highland Hills Estates, 1470 sq. ft. 3 bedrooms, 2 1/2 baths, full basement, walkout, 2 car garage, large beautiful landscaping, 51,700. REALTY WORLD/285-3365.

026 Mobile Homes For Sale
HIGHLAND Greens, 1986 North, Highland Hills Estates, 1470 sq. ft. 3 bedrooms, 2 1/2 baths, full basement, walkout, 2 car garage, large beautiful landscaping, 51,700. REALTY WORLD/285-3365.

Cliff's
CONDOMINIUMS
Phase II Now Open
Model homes, phone number, address, website information.

026 Mobile Homes For Sale
HIGHLAND Greens, 1986 North, Highland Hills Estates, 1470 sq. ft. 3 bedrooms, 2 1/2 baths, full basement, walkout, 2 car garage, large beautiful landscaping, 51,700. REALTY WORLD/285-3365.

026 Mobile Homes For Sale
HIGHLAND Greens, 1986 North, Highland Hills Estates, 1470 sq. ft. 3 bedrooms, 2 1/2 baths, full basement, walkout, 2 car garage, large beautiful landscaping, 51,700. REALTY WORLD/285-3365.

026 Mobile Homes For Sale
HIGHLAND Greens, 1986 North, Highland Hills Estates, 1470 sq. ft. 3 bedrooms, 2 1/2 baths, full basement, walkout, 2 car garage, large beautiful landscaping, 51,700. REALTY WORLD/285-3365.

026 Mobile Homes For Sale
HIGHLAND Greens, 1986 North, Highland Hills Estates, 1470 sq. ft. 3 bedrooms, 2 1/2 baths, full basement, walkout, 2 car garage, large beautiful landscaping, 51,700. REALTY WORLD/285-3365.

026 Mobile Homes For Sale
HIGHLAND Greens, 1986 North, Highland Hills Estates, 1470 sq. ft. 3 bedrooms, 2 1/2 baths, full basement, walkout, 2 car garage, large beautiful landscaping, 51,700. REALTY WORLD/285-3365.

026 Mobile Homes For Sale
HIGHLAND Greens, 1986 North, Highland Hills Estates, 1470 sq. ft. 3 bedrooms, 2 1/2 baths, full basement, walkout, 2 car garage, large beautiful landscaping, 51,700. REALTY WORLD/285-3365.

You have the opportunity to buy the most prestigious apartments on Ford Lake.
1 + 2 bedrooms - Lakefront balconies - All appliances furnished - 1 1/2 car garage - Washer & Dryer furnished - Pool, Sauna, Clubhouse - Fully carpeted - Docking option - Credit Financing Available to Qualified Buyers - From \$69,500

Century 21
SUBURBAN REALTORS
Choose a condo from these excellent locations. Applegate II, Lexington, Country Place or Old Orchard. Pick from ranches, townhouses or one story up. Starting at \$75,900. Call 423-9200 for an Appointment or 349-1212.

global
MOBILE HOMES INC.
NORTHFIELD ESTATES
SALE
Homes are set ready for immediate occupancy

026 Mobile Homes For Sale
HIGHLAND Greens, 1986 North, Highland Hills Estates, 1470 sq. ft. 3 bedrooms, 2 1/2 baths, full basement, walkout, 2 car garage, large beautiful landscaping, 51,700. REALTY WORLD/285-3365.

026 Mobile Homes For Sale
HIGHLAND Greens, 1986 North, Highland Hills Estates, 1470 sq. ft. 3 bedrooms, 2 1/2 baths, full basement, walkout, 2 car garage, large beautiful landscaping, 51,700. REALTY WORLD/285-3365.

026 Mobile Homes For Sale
HIGHLAND Greens, 1986 North, Highland Hills Estates, 1470 sq. ft. 3 bedrooms, 2 1/2 baths, full basement, walkout, 2 car garage, large beautiful landscaping, 51,700. REALTY WORLD/285-3365.

026 Mobile Homes For Sale
HIGHLAND Greens, 1986 North, Highland Hills Estates, 1470 sq. ft. 3 bedrooms, 2 1/2 baths, full basement, walkout, 2 car garage, large beautiful landscaping, 51,700. REALTY WORLD/285-3365.

WOODBRIDGE HILLS
Luxury condominium homes nestled in a charming wooded setting.

026 Mobile Homes For Sale
HIGHLAND Greens, 1986 North, Highland Hills Estates, 1470 sq. ft. 3 bedrooms, 2 1/2 baths, full basement, walkout, 2 car garage, large beautiful landscaping, 51,700. REALTY WORLD/285-3365.

026 Mobile Homes For Sale
HIGHLAND Greens, 1986 North, Highland Hills Estates, 1470 sq. ft. 3 bedrooms, 2 1/2 baths, full basement, walkout, 2 car garage, large beautiful landscaping, 51,700. REALTY WORLD/285-3365.

026 Mobile Homes For Sale
HIGHLAND Greens, 1986 North, Highland Hills Estates, 1470 sq. ft. 3 bedrooms, 2 1/2 baths, full basement, walkout, 2 car garage, large beautiful landscaping, 51,700. REALTY WORLD/285-3365.

026 Mobile Homes For Sale
HIGHLAND Greens, 1986 North, Highland Hills Estates, 1470 sq. ft. 3 bedrooms, 2 1/2 baths, full basement, walkout, 2 car garage, large beautiful landscaping, 51,700. REALTY WORLD/285-3365.

026 Mobile Homes For Sale
HIGHLAND Greens, 1986 North, Highland Hills Estates, 1470 sq. ft. 3 bedrooms, 2 1/2 baths, full basement, walkout, 2 car garage, large beautiful landscaping, 51,700. REALTY WORLD/285-3365.

026 Mobile Homes For Sale
HIGHLAND Greens, 1986 North, Highland Hills Estates, 1470 sq. ft. 3 bedrooms, 2 1/2 baths, full basement, walkout, 2 car garage, large beautiful landscaping, 51,700. REALTY WORLD/285-3365.

Adler
Buyer Participation Welcome
229-5722

Grand Opening Crystal Beach
4 styles from 1100 sq. ft. STARTING AT \$67,000

026 Mobile Homes For Sale
HIGHLAND Greens, 1986 North, Highland Hills Estates, 1470 sq. ft. 3 bedrooms, 2 1/2 baths, full basement, walkout, 2 car garage, large beautiful landscaping, 51,700. REALTY WORLD/285-3365.

026 Mobile Homes For Sale
HIGHLAND Greens, 1986 North, Highland Hills Estates, 1470 sq. ft. 3 bedrooms, 2 1/2 baths, full basement, walkout, 2 car garage, large beautiful landscaping, 51,700. REALTY WORLD/285-3365.

026 Mobile Homes For Sale
HIGHLAND Greens, 1986 North, Highland Hills Estates, 1470 sq. ft. 3 bedrooms, 2 1/2 baths, full basement, walkout, 2 car garage, large beautiful landscaping, 51,700. REALTY WORLD/285-3365.

026 Mobile Homes For Sale
HIGHLAND Greens, 1986 North, Highland Hills Estates, 1470 sq. ft. 3 bedrooms, 2 1/2 baths, full basement, walkout, 2 car garage, large beautiful landscaping, 51,700. REALTY WORLD/285-3365.

026 Mobile Homes For Sale
HIGHLAND Greens, 1986 North, Highland Hills Estates, 1470 sq. ft. 3 bedrooms, 2 1/2 baths, full basement, walkout, 2 car garage, large beautiful landscaping, 51,700. REALTY WORLD/285-3365.

154 Restaurant 165 Help Wanted 155 Help Wanted 165 Help Wanted 165 Help Wanted 165 Help Wanted 165 Help Wanted 165 Help Wanted 165 Help Wanted 165 Help Wanted

EXPERIENCED bartenders. Apply in person. O'Brien, 3185 Woodward, Brighton, (313)227-4000.

NEAT ladies with pleasant voice to work from the comfort of our office. Telephone survey work for local Milford High School. Excellent pay. \$30.00 per hour. Apply in person. Mackintosh, 135 E. Main Street, Northville.

CHILD & FAMILY SERVICES. MS. BROWN. Full-time position in private home. Excellent pay. \$30.00 per hour. Apply in person. Mackintosh, 135 E. Main Street, Northville.

AIRLINES ATTENTION. Best Western Motels now accepting applications for housekeepers. All proper-tion. Whitehouse, 135 E. Main Street, Northville.

MANAGERS IN TRAINING. New Management programs now accepting applications for housekeepers. All proper-tion. Whitehouse, 135 E. Main Street, Northville.

ACTION AUTO STORES. Will soon be opening an exciting new store in South Lyon. Excellent pay. \$30.00 per hour. Apply in person. Mackintosh, 135 E. Main Street, Northville.

FACTORY WORKERS Summer Jobs Now Available! Immediate temporary assignments both short and long term. Kelly Services, Inc. 500 W. Main St., Brighton.

TEMPORARY ASSIGNMENTS FOR: CLERKS, TYPISTS, SWITCHBOARD OPERATORS, DATA ENTRY OPERATORS. Kelly Services, Inc. 500 W. Main St., Brighton.

ATTENTION MEN AND WOMEN WHO MEET THE QUALIFICATIONS. High school graduate. Excellent pay. \$30.00 per hour. Apply in person. Mackintosh, 135 E. Main Street, Northville.

AIRLINES ATTENTION. Best Western Motels now accepting applications for housekeepers. All proper-tion. Whitehouse, 135 E. Main Street, Northville.

MANAGERS IN TRAINING. New Management programs now accepting applications for housekeepers. All proper-tion. Whitehouse, 135 E. Main Street, Northville.

ACTION AUTO STORES. Will soon be opening an exciting new store in South Lyon. Excellent pay. \$30.00 per hour. Apply in person. Mackintosh, 135 E. Main Street, Northville.

FACTORY WORKERS Summer Jobs Now Available! Immediate temporary assignments both short and long term. Kelly Services, Inc. 500 W. Main St., Brighton.

TEMPORARY ASSIGNMENTS FOR: CLERKS, TYPISTS, SWITCHBOARD OPERATORS, DATA ENTRY OPERATORS. Kelly Services, Inc. 500 W. Main St., Brighton.

EXPERIENCED bartenders. Apply in person. O'Brien, 3185 Woodward, Brighton, (313)227-4000.

ATTENTION MEN AND WOMEN WHO MEET THE QUALIFICATIONS. High school graduate. Excellent pay. \$30.00 per hour. Apply in person. Mackintosh, 135 E. Main Street, Northville.

AIRLINES ATTENTION. Best Western Motels now accepting applications for housekeepers. All proper-tion. Whitehouse, 135 E. Main Street, Northville.

MANAGERS IN TRAINING. New Management programs now accepting applications for housekeepers. All proper-tion. Whitehouse, 135 E. Main Street, Northville.

ACTION AUTO STORES. Will soon be opening an exciting new store in South Lyon. Excellent pay. \$30.00 per hour. Apply in person. Mackintosh, 135 E. Main Street, Northville.

FACTORY WORKERS Summer Jobs Now Available! Immediate temporary assignments both short and long term. Kelly Services, Inc. 500 W. Main St., Brighton.

TEMPORARY ASSIGNMENTS FOR: CLERKS, TYPISTS, SWITCHBOARD OPERATORS, DATA ENTRY OPERATORS. Kelly Services, Inc. 500 W. Main St., Brighton.

EXPERIENCED bartenders. Apply in person. O'Brien, 3185 Woodward, Brighton, (313)227-4000.

ATTENTION MEN AND WOMEN WHO MEET THE QUALIFICATIONS. High school graduate. Excellent pay. \$30.00 per hour. Apply in person. Mackintosh, 135 E. Main Street, Northville.

AIRLINES ATTENTION. Best Western Motels now accepting applications for housekeepers. All proper-tion. Whitehouse, 135 E. Main Street, Northville.

MANAGERS IN TRAINING. New Management programs now accepting applications for housekeepers. All proper-tion. Whitehouse, 135 E. Main Street, Northville.

ACTION AUTO STORES. Will soon be opening an exciting new store in South Lyon. Excellent pay. \$30.00 per hour. Apply in person. Mackintosh, 135 E. Main Street, Northville.

FACTORY WORKERS Summer Jobs Now Available! Immediate temporary assignments both short and long term. Kelly Services, Inc. 500 W. Main St., Brighton.

TEMPORARY ASSIGNMENTS FOR: CLERKS, TYPISTS, SWITCHBOARD OPERATORS, DATA ENTRY OPERATORS. Kelly Services, Inc. 500 W. Main St., Brighton.

EXPERIENCED bartenders. Apply in person. O'Brien, 3185 Woodward, Brighton, (313)227-4000.

ATTENTION MEN AND WOMEN WHO MEET THE QUALIFICATIONS. High school graduate. Excellent pay. \$30.00 per hour. Apply in person. Mackintosh, 135 E. Main Street, Northville.

AIRLINES ATTENTION. Best Western Motels now accepting applications for housekeepers. All proper-tion. Whitehouse, 135 E. Main Street, Northville.

MANAGERS IN TRAINING. New Management programs now accepting applications for housekeepers. All proper-tion. Whitehouse, 135 E. Main Street, Northville.

ACTION AUTO STORES. Will soon be opening an exciting new store in South Lyon. Excellent pay. \$30.00 per hour. Apply in person. Mackintosh, 135 E. Main Street, Northville.

FACTORY WORKERS Summer Jobs Now Available! Immediate temporary assignments both short and long term. Kelly Services, Inc. 500 W. Main St., Brighton.

TEMPORARY ASSIGNMENTS FOR: CLERKS, TYPISTS, SWITCHBOARD OPERATORS, DATA ENTRY OPERATORS. Kelly Services, Inc. 500 W. Main St., Brighton.

EXPERIENCED bartenders. Apply in person. O'Brien, 3185 Woodward, Brighton, (313)227-4000.

ATTENTION MEN AND WOMEN WHO MEET THE QUALIFICATIONS. High school graduate. Excellent pay. \$30.00 per hour. Apply in person. Mackintosh, 135 E. Main Street, Northville.

AIRLINES ATTENTION. Best Western Motels now accepting applications for housekeepers. All proper-tion. Whitehouse, 135 E. Main Street, Northville.

MANAGERS IN TRAINING. New Management programs now accepting applications for housekeepers. All proper-tion. Whitehouse, 135 E. Main Street, Northville.

ACTION AUTO STORES. Will soon be opening an exciting new store in South Lyon. Excellent pay. \$30.00 per hour. Apply in person. Mackintosh, 135 E. Main Street, Northville.

FACTORY WORKERS Summer Jobs Now Available! Immediate temporary assignments both short and long term. Kelly Services, Inc. 500 W. Main St., Brighton.

TEMPORARY ASSIGNMENTS FOR: CLERKS, TYPISTS, SWITCHBOARD OPERATORS, DATA ENTRY OPERATORS. Kelly Services, Inc. 500 W. Main St., Brighton.

EXPERIENCED bartenders. Apply in person. O'Brien, 3185 Woodward, Brighton, (313)227-4000.

ATTENTION MEN AND WOMEN WHO MEET THE QUALIFICATIONS. High school graduate. Excellent pay. \$30.00 per hour. Apply in person. Mackintosh, 135 E. Main Street, Northville.

AIRLINES ATTENTION. Best Western Motels now accepting applications for housekeepers. All proper-tion. Whitehouse, 135 E. Main Street, Northville.

MANAGERS IN TRAINING. New Management programs now accepting applications for housekeepers. All proper-tion. Whitehouse, 135 E. Main Street, Northville.

ACTION AUTO STORES. Will soon be opening an exciting new store in South Lyon. Excellent pay. \$30.00 per hour. Apply in person. Mackintosh, 135 E. Main Street, Northville.

FACTORY WORKERS Summer Jobs Now Available! Immediate temporary assignments both short and long term. Kelly Services, Inc. 500 W. Main St., Brighton.

TEMPORARY ASSIGNMENTS FOR: CLERKS, TYPISTS, SWITCHBOARD OPERATORS, DATA ENTRY OPERATORS. Kelly Services, Inc. 500 W. Main St., Brighton.

EXPERIENCED bartenders. Apply in person. O'Brien, 3185 Woodward, Brighton, (313)227-4000.

ATTENTION MEN AND WOMEN WHO MEET THE QUALIFICATIONS. High school graduate. Excellent pay. \$30.00 per hour. Apply in person. Mackintosh, 135 E. Main Street, Northville.

AIRLINES ATTENTION. Best Western Motels now accepting applications for housekeepers. All proper-tion. Whitehouse, 135 E. Main Street, Northville.

MANAGERS IN TRAINING. New Management programs now accepting applications for housekeepers. All proper-tion. Whitehouse, 135 E. Main Street, Northville.

ACTION AUTO STORES. Will soon be opening an exciting new store in South Lyon. Excellent pay. \$30.00 per hour. Apply in person. Mackintosh, 135 E. Main Street, Northville.

FACTORY WORKERS Summer Jobs Now Available! Immediate temporary assignments both short and long term. Kelly Services, Inc. 500 W. Main St., Brighton.

TEMPORARY ASSIGNMENTS FOR: CLERKS, TYPISTS, SWITCHBOARD OPERATORS, DATA ENTRY OPERATORS. Kelly Services, Inc. 500 W. Main St., Brighton.

EXPERIENCED bartenders. Apply in person. O'Brien, 3185 Woodward, Brighton, (313)227-4000.

If you don't keep their names alive, who will?

An invitation to place the name of a member of your family who immigrated to America in the only national museum created to honor them.

Whether your ancestors first set foot on American soil at Ellis Island, or entered through another gateway, here is a unique opportunity to show your gratitude. And to present your family with a gift that will be meaningful now and for generations to come.

When you make a \$100 contribution to restore Ellis Island, the name you designate will be permanently placed on the newly

created American Immigrant Wall of Honor. You can choose the name of an ancestor or just your own family name. And you'll receive an Official Certificate of Registration. To register additional names, list each name and country of origin on a separate sheet. And remember, there is a minimum gift of \$100 for each.

Please send your contribution today. By acting now you assure that the Ellis Island Immigration Museum will be a place to honor your own heritage, as well as a monument to the great American traditions of freedom, hope and opportunity.

Keep the Dream Alive



Ellis Island Foundation, Inc.
P.O. Box ELLIS, New York, N.Y. 10163

I would like to register my ancestor's name on the American Immigrant Wall of Honor:

Name of individual or family (please print) _____

Country of origin _____

Enclosed is my tax-deductible contribution for: \$100 Other \$ _____

Please make checks payable to "Ellis Island." Check enclosed. Or please charge my

Credit Card # _____ Expires _____

Mr. _____
Ms. _____
Name (please print) _____

Signature (Required if using credit card) _____

Street _____
City _____ State _____ Zip _____



The Statue of Liberty-Ellis Island Foundation, Inc. is a charitable corporation to which contributions are tax-deductible to the extent allowed by law. A copy of the last financial report filed with the Department of State may be obtained by writing to: New York State, Department of State, Office of Charities Regulation, Albany, New York 12231, or The Statue of Liberty-Ellis Island Foundation, Inc., 52 Vanderbilt Avenue, New York, New York 10017-3808. Photo courtesy of California Museum of Photography, University of California, Riverside.

240 Automobiles	240 Automobiles	241 Vehicles Under \$1000.
1985 DODGE Omni GLH Turbo. Low miles. \$4,200 negotiable. (313)223-2933.	1986 MUSTANG hatchback with 1-top, 4 speed, low mileage. Excellent condition. Best offer. (313)431-6238.	1987 TOYOTA Land Cruiser. Automatic transmission, rebuilt engine, 300 hp, new tires, needs work. \$700. (313)344-8797.
1985 ESCORT 4 speed, 4 door, clean. \$2,400. (517)223-8337.	1988 OLDSMOBILE Toronado Fully equipped. \$10,500. (313)882-1283 after 6 pm.	1985 PLYMOUTH VALIANT. Slant 6, runs great. \$750 negotiable. (313)887-2986.
1985 MUSTANG, 4 speed, stereo, cruise, new tires, \$2,000. (313)229-8500.	1986 OLDSMOBILE Cutlass Ciera SL, 2 door, 4 cylinder, 16,000 miles, power windows and power seats. \$8,100. (313)244-4525.	1970 TWO door, Pontiac Catalina, \$500. Runs. (313)229-9142.
1985 MERCURY Lynx. Diesel, low miles. 5 speed, air conditioning, stereo, tilt wheel, exceptionally clean. Perfect commuter car. \$4,000 firm. (313)887-4447.	1986 PONTIAC T1000, 4 speed, am/fm radio, very good condition. \$3,100. \$13,950-4910.	1971 SATELLITE Sebring. Very restorable. \$950. Original owner. (313)227-4388.
1985 OLDSMOBILE Regency sedan. Fully loaded. (517)223-8500.	1987 DELTA 88 Brougham. Spotless, 13,500 miles. All power extras. \$12,250. (313)229-2588.	1974 DODGE Dart. Good beater. Good mechanical shap. Transmission slips. \$550 or best. (517)546-7618.
1985% ESCORT GL 5 speed manual. Loaded. \$3000 negotiable. (517)851-8837 after 6 p.m.	1987 FORMULA 350. Custom built by GM. All high perf. Florida car. Garaged winters. Alpine, air, low miles, irreplaceable. \$13,700. Serious enquiries only. (313)227-5178.	1975 MALIBU. Runs great, body rough. \$350. 1976 Firebird, body rough. \$300. (313)887-2988.
1985 PLYMOUTH Horizon. Executive car. High mileage, auto and air. \$2,800 or best offer. (517)223-2559.	1987 MUSTANG GT 1-top, loaded, low mileage. 5 speed. \$13,900 or best offer. (313)229-2588.	1976 CHEVROLET Caprice. 4 door, 60,000 miles. Power steering, brakes, windows and cruise. \$550. After 5:30 p.m., weekdays (313)885-2888.
1985 PLYMOUTH Reliant SE, 4 door, automatic, air. Excellent condition. \$3,900. (313)348-2004.	1987 OLDSMOBILE Cutlass Supreme. 2 door, v6, 16,000 miles. (313)348-5381.	1976 OLDSMOBILE Cutlass Supreme Deluxe. Needs engine. Good tires, brakes, exhaust, rear bumper, good riding. \$400 or best offer. (313)885-2888.
1985 PONTIAC Fiero GT, 16,000 miles. (313)884-1783 after 6 p.m.	1987 PONTIAC Firebird. Fully loaded including 1-top. \$10,500. (313)229-2588.	1976 VOLKSWAGON Rabbit. Gas engine. 4 speed. Has some new parts, but needs work. Fair it out. (313)229-2588.
1985 SAAB 4 door, air, stereo, 5 speed. \$6,600. (517)846-0881.	1986 ESCORT GT, air, cruise, tilt, stereo cassette, low miles. Asking \$9,200. Or best. (517)223-7262.	1977 BUICK 2 door, V6, must sell, runs great. \$500. (313)232-8057.
1986 BUICK Skylark. 4 cylinder. 60,000 miles. Asking \$9,200. (313)338-0919.	1986 CHRYSLER LeBaron. 4,000 miles. Loaded. Excellent condition. \$5,900 or best offer. (313)229-2882.	1977 BUICK Skylark. Good condition. \$3,000 miles. \$650. Keith (313)453-5575.
1986 FORD Escort. 22 turbo, 5 speed, loaded, new Turbo charger. \$5,900. (313)887-4447 evenings.	1986 OLDSMOBILE Cutlass Supreme. 2 door, v6, 16,000 miles. (313)348-5381.	1977 CAMARO. V-8. Needs work. \$600. (313)428-4427.
1986 ESCORT I wagon, automatic, air, rear defrost, stereo, roof-rack, rust-proofed, 31,000 miles, nice. \$4,800. (313)229-2918.	1986 ESCORT L wagon, automatic, air, rear defrost, stereo, roof-rack, rust-proofed, 31,000 miles, nice. \$4,800. (313)229-2918.	1977 CAMARO. Runs good, new clutch assembly. \$550 or best. (313)231-1386 after 3 p.m.
1986 FIREBIRD. 60,000 HIGHWAY MILES. AIR COND. POWER STEERING. BRAKES. FUEL INJECTED. RUST PROOFED. EXCELLENT CONDITION. \$7,850. AFTER 6 P.M. (517)546-4389.	1986 ESCORT L wagon, automatic, air, rear defrost, stereo, roof-rack, rust-proofed, 31,000 miles, nice. \$4,800. (313)229-2918.	
1986 FORD Escort. 2 door automatic, 18,000 miles. Loaded, extended warranty. \$5500. (517)546-3868.	1986 FORD Thunderbird. Loaded, 22,000 miles. \$10,000. (517)521-3303.	
1986 GMC Suburban. Loaded. 39,000 miles. \$13,500. (313)437-3126.	1986 MERCURY Cougar. Many extras, low mileage. \$7,995. (313)629-2035.	
1986 MERCURY Cougar. Many extras, low mileage. \$7,995. (313)629-2035.	1986 MERKUR. 5 speed, sunroof, Popsy red, mint. \$10,200. (313)348-5332.	

DOUBLE REBATE

Up To \$2000

WE MUST SELL 50 MORE CARS AND TRUCKS BY JUNE 18th

<p>SPECTRUM Stock No. 8274</p> <p>\$8450</p> <p>\$1000 Factory Rebate</p> <p>\$1000 Dealer Rebate</p> <p>\$200 Additional Savings</p> <p>\$7250*</p> <p>1.5 L4, 2 bbl, 5 spd trans., blue cloth, steel belted tires, front wheel drive, plus more factory equipment</p>	<p>CELEBRITY Stock No. 8113</p> <p>\$12,827</p> <p>\$500 Factory Rebate</p> <p>\$500 Dealer Rebate</p> <p>\$687 Additional Savings</p> <p>\$11,160</p> <p>Air conditioning, rear defogger, AM/FM stereo, intermittent wipers, cruise control, floor mats, tilt wheel, steel belted tires, w/w, auto trans., power steering & brakes</p>
<p>FULL SIZE CONVERSION VAN</p> <p>\$19,652</p> <p>\$500 Factory Rebate</p> <p>\$500 Dealer Rebate</p> <p>\$1,925 Additional Savings</p> <p>\$16,727</p> <p>Power door locks, tinted glass, A/C, intermittent wipers, cruise control, tilt wheel, AM/FM, 4 captain's chairs, sofa bed, 3 boy windows with screens, reading lights, custom side walls and engine cover, custom striping & running boards</p>	<p>CORSICA Stock No. 8455</p> <p>\$11,614</p> <p>\$1000 Option Package Discount</p> <p>\$400 Factory Rebate</p> <p>\$400 Dealer Rebate</p> <p>\$200 Additional Savings</p> <p>\$9614</p> <p>Tinted glass, A/C, cloth trim, rear defogger, auto trans., with console, steel belted tires w/w, power steering, power brakes, H/D battery.</p>

CHAMPION CHEVROLET

603 W. Grand River, Downtown Brighton.

229-8800

OPEN SATURDAY 10-4

BRIGHTON DISCOUNT OUTLET

USED CAR SPECIALS

\$100 Rebate ON AUTO PURCHASE

Must be Presented at Time of Sale

LOOK ONLY \$4495 YOUR CHOICE \$4495

- 1985 PLY RELIANT WAGON Automatic, Air, Nice Family Car
- 1983 LTD CROWN VICTORIA Gorgeous
- 1984 MERC. TOPAZ 2 DR. Burgundy, Must See
- 1984 TOPAZ 4 Door, Stock, Air, Runs Great
- 1985 DODGE 4 DR DIPLOMAT Loaded

WE FINANCE BAD CREDIT! SLOW CREDIT! NEW CREDIT!

LOOK ONLY \$2995 YOUR CHOICE \$2995

- 1985 DODGE OMNI
- 1984 DODGE OMNI
- 1984 BUICK SKYHAWK WAGON
- 1983 OLDS OMEGA
- 1982 PONTIAC J-2000
- 1982 DODGE 4x4 D-50

LOOK ONLY \$1995 YOUR CHOICE \$1995

- 1976 FORD RANCHERO With Cap
- 1983 PONTIAC T-1000 Stock
- 1981 TOYOTA CELICA GT Runs Great
- 1981 FORD GRANADA 4 Dr.

BRIGHTON DISCOUNT OUTLET

9797 E. Grand River, Brighton

Call (313) 227-7253

"CAR BUYING MADE FUN AGAIN"

Hours: Mon. & Thurs. 8:30-9pm; Wed., Tues. & Fri. 8:30-9pm; Sat. 9:00-4pm

U.S. SAVINGS BONDS

1-800-US-BONDS

USED CAR VALUES!

- 1978 FORD STATION WAGON \$1195 Loaded, Priced To Sell
- 1981 FORD FAIRMOUNT \$2495 2 Dr., P.S., P.B., Auto, A/C, Low Miles, AM/FM Cassette
- 1985 PLY. HORIZON \$3695 4 Dr., P.S., P.B., Low Miles
- 1985 FORD ESCORT GL \$3995 2 Dr., P.S., Auto
- 1983 OLDS FIRENZA SX \$4995 Loaded, 2 Dr., Hatchback
- 1984 BUICK REGAL \$4995 P.S., P.B., Auto, AM/FM, A/C
- 1986 FORD MUSTANG LX \$4995 P.S., P.B., 4 Cyl., 4 Speed, Sun Roof, Cruise
- 1983 CHEV. CELEBRITY \$5995 P.S., P.B., AM/FM, 38,000 Miles. A/C
- 1987 CAVALIER \$7395 4 Dr., P.S., P.B., Auto, 18,000 Miles
- 1986 T-BIRD \$7995 P.S., P.B., Tilt, Cruise, 5 Speed, Like New
- 1985 CHEV. S-10 BLAZER \$6395 P.S., P.B., Auto, Tilt, Cruise, AM/FM Cassette
- 1986 CHEV. 4x4 PICKUP \$9995 P.S., P.B., Auto, Tilt, Cruise

CHAMPION CHEVROLET

603 W. Grand River, Downtown Brighton.

229-8800

BRIGHTON CHRYSLER

HOWELL USED CARS

Dave Lewis Howell Used Car Mgr.

Balloon Festival Of Savings!

Car of the Week!

'87 RENAULT GTA CONVERTIBLE \$9488 Loaded, Factory Official, 11,000 Miles, Warranty included	'85 CAMARO 2-28 V-8 Auto, 1-Top, Loaded, Red, Stereo Cassette, Warranty Included \$8988	'85 PLYMOUTH VOYAGER MINI VAN \$8788 Loaded, 7 Pass., Ready for Location, Warranty Included
'78 CUTLASS SUPREME BRO. \$1988 2 Dr., V-8, Loaded	'87 PLYMOUTH SUNDANCE \$7988 2-Door, Air, Stereo, Win, Cassette, Red Sporty	'84 CHEVY LEBARON \$4988 4 Dr., Loaded, Low Miles
'83 CHRYSLER LEBARON \$3988 4 Dr., Auto, Air, Loaded	'87 ALLIANCE \$6488 4 Dr., Auto, Air, Loaded, 8000 Miles	'80 PONTIAC SUNBIRD \$1488 4 Spd., Stereo, Win, Cassette, Stereo-Good Teen's Car
'86 MAZDA SHORT BED \$5688 4 Spd., O.D. Stripes, Wheel, Black, Warranty included	'87 CHEVY 1/2 TON PICKUP 4x4 \$12,488 351, V-8, Auto, 13,000 Miles, Warranty Available	'86 GMC JIMMY 4x4 \$9688 V-8, Auto, Loaded, Red, Warranty Available

BRIGHTON CHRYSLER

Plymouth - Dodge

HOWELL USED CARS

Dave Lewis - Used Car, Mgr.

804 E. Grand River • Next to Anthony's Restaurant

517-548-5190

Bob Jeannotte GMC TRUCK

The Tri-County Area's Newest GMC Dealer!

EXAMPLE: '88 GMC S-15 Longbed

Tinted glass, body moldings, wheel opening moldings, pulse wipers, 1625 lb. payload, dual mirrors, power brakes, power steering, V-6, 4 speed automatic over-drive, P205 radials, stereo with seek & scan, chrome bumper, styled wheels, gauges, cloth seats. #5074.

WAS: \$9880
Less - \$500
Less - \$300 MAIL IN COUPON

\$9,088*

*tax & license

\$500 Rebates**
on S-Jimmy's • S-Pickups • Sierra Pickups

Many more to choose from at similar savings!

Your #1 Truck Stop

453-2500

**Rebate excluded on 4.3 liter engine. Prior Sales excluded.

BOB JEANNOTTE

PONTIAC-GMC TRUCKS

14949 Sheldon Rd., Plymouth 453-2500
(Just N. of M-14 Jeffries Fwy.)
HOURS: 9-6 Tues., Wed. & Fri., 9-9 Mon. & Thurs.
*prices include destination charge & applicable rebates.
plus tax & title.

NEW DEALER

BRIGHTON

BRIGHTON, MI.

WE FINANCE BAD CREDIT! SLOW CREDIT! NEW CREDIT!

1985 CHEVY Z-28 CAMARO	Black, 1700s Loaded	SAVE \$7,495
1984 FORD MUSTANG GT	Black, 5 Speed, Air, Power Windows	\$6995
1986 FORD ESCORT	Black, 5 Speed, Air, Power Windows	\$6995
1987 FORD AEROSTAR XLT	Black, 5 Speed, Air, Power Windows	\$12,388
1986 FORD MUSTANG	Black, 5 Speed, Air, Power Windows	\$8995
1985 CHEVY S-10 BLAZER 4x4	Black, 5 Speed, Air, Power Windows	\$8295
1985 MERCURY CAPRI	Black, 5 Speed, Air, Power Windows	\$8995
1986 LTD II	Black, 5 Speed, Air, Power Windows	\$7988
1985 FORD F-150 PICKUP	Black, 5 Speed, Air, Power Windows	\$6888
1985 FORD THUNDERBIRD TURBO COUPE	Black, 5 Speed, Air, Power Windows	\$8795
1985 PONTIAC 6000 LE	Black, 5 Speed, Air, Power Windows	\$7895
1985 CADILLAC SEDAN DEVILLE	Black, 5 Speed, Air, Power Windows	\$10,500
1986 LINCOLN TOWN CAR	Black, 5 Speed, Air, Power Windows	SAVE
1986 DODGE ARIES	Black, 5 Speed, Air, Power Windows	SAVE

We Are Dealing!

1986 FORD F-150 PICKUP	Black, 5 Speed, Air, Power Windows	\$7389
1986 FORD ESCORT	Black, 5 Speed, Air, Power Windows	\$5298
1987 FORD ESCORTS	Black, 5 Speed, Air, Power Windows	\$6498
1985 BRONCO II	Black, 5 Speed, Air, Power Windows	\$8488
1985 CHEVY C-20 4x4 PICKUP	Black, 5 Speed, Air, Power Windows	\$8995
1986 FORD RANGER	Black, 5 Speed, Air, Power Windows	SAVE

Many Cars To Choose From

BRIGHTON

BRIGHTON, MI.

"Car Buying Made Fun Again!"

8704 Grand River, (313) 227-1171

HOURS: Mon. & Thurs. 8:30-9pm; Wed., Tues. & Fri. 8:30-6pm; Sat. 9:00-4pm

Who you gonna Call.....

229-4100

Price Buster Slam Dunk Special

'82 Ford F-250 4x4
4 Speed, Creep Gear
\$2995

"For Fast Breakin' Used Car Deals Come Se Us First!"

Don Allred
Used Car Manager

'85 Plymouth Voyager
7 Passenger, Auto, PS/PB
\$6995

1983 Dodge 400
4 Door, Auto, Air, PS/PB, Cruise, Tilt
\$2995

1985 Ford Escort	\$2995
1983 Mustang GLX Convertible, All The Toys	\$5995
1984 Chevy Cavalier 4 Door, Auto, Air	\$3995
1987 Dodge Omni PS/PB, Stereo	\$4795
1986 Pontiac Sunbird PS/PB, 2 Door	\$4995
1981 Buick Wagon Loaded! All The Toys	\$2395

We Buy Clean Used Cars

BRIGHTON CHRYSLER

PLYMOUTH • DODGE
9827 E. Grand River 229-4100
"Home of the Price Buster"

Portrait of the Great American Investor

It's his job to know good advertising—and he also knows a good investment. Terry Wilson puts his money in U.S. Savings Bonds.

Bonds now pay competitive rates, like money market accounts. Find out more, call 1-800-US-BONDS.

U.S. SAVINGS BONDS
THE GREAT AMERICAN INVESTMENT

Bonds held less than five years earn a lower rate. A public service of this publication.

ANDERSON HONDA CARS

LOOK AT ALL THE ADS AND THEN REMEMBER:

WE WILL NOT BE UNDERSOLD

LET US PROVE IT TO YOU!

Located on Telegraph Rd.
between Orchard Lake Rd. & Square Lake Rd.

ANDERSON HONDA CARS

BLOOMFIELD HILLS 333-3200

Used car sale!

THIS WEEK'S SPECIAL

1983 CADILLAC FLEETWOOD COUPE
One Owner, Lady Driver, 45,000 Miles
\$6395

1985 CENTURY T-TYPE 2 DR.
Loaded, Sunroof
\$4345

1985 CHEVROLET CAVALIER 4 DR.
Auto, Air
\$4345

1987 OLDSMOBILE 98 BROUGHAM COUPE
Loaded
\$12,995

1984 CHEVROLET CAMARO
V-6, 5 Speed, Air, Stereo
\$4995

1985 CHRYSLER TOWN & COUNTRY WAGON
Auto, Air, Stereo
\$6395

1984 CADILLAC SEVILLE
Loaded, 2 To Choose From
\$11,450

1985 CHEVROLET 1/2 TON SILVERADO
Pick-Up, Loaded
\$6995

1985 CHEVROLET C-20 3/4 TON
Pick-Up, V-8, Auto, 28,000 Miles
\$7495

FEIGLEY & WATT

USED CARS INC.

720 G.M. Rd., Milford
684-2277 or 684-CARS

"Our Hosts Are Off To The Graduates Of 1988. Come Check These Graduation Transportation Specials!"

'88 PLYMOUTH HORIZON

OVER 20 TO CHOOSE FROM

7 STANDARD FEATURES

34 MPG HIGHWAY 25 MPG CITY

CHRYSLER EMPLOYEES WELCOME

5 DOOR HATCHBACK
WAS \$6348
NOW **\$5802***

\$109.41 PER MO.**

- Power Brakes
- Rear Defroster
- Tinted Glass
- Intermittent Wipers
- Rear Wiper/Washer
- Rally Type Instrumentation
- 2.2 Electronic Fuel Injection
- 5 Speed Transmission
- Cloth Seats
- All Season Radial Tires
- Rally Wheels
- Rear Security Shelf
- Visor Vanity Mirror
- Sport Steering Wheel
- Trunk Dress Up
- & More, Much More!

*Plus title & destination. Incentives back to dealer. Sales tax not included.
**1988 down cash or trade, 36 months, 9.9% APR

BRIGHTON

CHRYSLER/PLYMOUTH/DODGE
9827 E. Grand River
229-4100

SAVE USED CAR SALE

241 Vehicles Under \$1000

1984 OLDSMOBILE CIERA 4 DR.
Auto, Air, Stereo, P.S., P.B. W/ire Wheel Covers
\$4670

1984 CHEVETTE
4 Dr., 4 Spd., Stereo Cassette, Clean, Low Miles, Red.
\$2920

1985 FORD ESCORT
2 Door, 5 Speed, Burgundy, Great Mileage, Now Just!
\$2660

1985 DODGE 600
Loaded, 4 Dr., Turbo, Plus More Only
\$4640

TRUCKS

1985 DODGE B-250 PASSENGER VAN
V-8, Auto, Air, P.S., P.B., Sunscreen Glass, T.H. Cruise, P.W., P.L., Low Miles
\$8990

1986 CHEVY S-10
Pick-Up Sport Trim, V-6, P.W., P.L., Tilt, Alloy Wheels, Sharp Red Truck
\$5880

1986 FORD RANGER PICKUP
Special Wheels, Bed Cover, Nice New Only
\$4880

1984 DODGE D-50
Power Ram 4x4, Auto, Air, Cap. Clean
\$4990

"Before You Buy Your Next Car... Ya Gotta See Us."

No Hidden Extras! We're Your Up Front Dealer!

HIGHLAND

M-59 at Duck Lk. Rd.
887-3222

We're Dealing!

Check These Prices And You'll Be A Believer!

1988 OLDS CALAIS 4 DOOR
List \$12,1488
Sale Price \$10,988
Rebate \$400
Final Price **\$10,588***

1988 BUICK CENTURY CUSTOM 4 DOOR
List \$13,846
Sale Price \$12,488
Rebate \$500
Final Price **\$11,988***

FEIGLEY MOTOR SALES

750 G.M. Road, Milford
684-1414

*Just Add 4% Michigan Tax, Title, & Plates Fee

SPIKER

LARGEST VOLUME FORD-MERCURY DEALERSHIP

IN SOUTHEASTERN MICHIGAN FOR 21 CONTINUOUS YEARS

222

FORD'S-MERCURY'S FORD TRUCKS

1988, 1988 1/2, 1989 Models

IMMEDIATE DELIVERY

\$1000.00 CASH BACK

Ford Motor Employees A & Z Plans Are Eligible
See Spiker Ford - Mercury For Details

SAVE BIG \$\$\$ '88 TRACERS

2 Dr., 4 Drs., Wagons
18 To Choose, From
\$7088*

ALL FACTORY EQUIPMENT
NO HIDDEN CHARGES

*Plus Dest., Taxes, Plates, Includes Factory Rebates

BUY or LEASE FORD - MERCURY FORD TRUCKS
ORDER YOURS TODAY
A, B, X & Z PLANS WELCOME

Home of the Nearsighted Appraiser

SELLING FORDS AND MERCURYS SINCE 1950
BRING US YOUR BEST DEAL... WE'LL MAKE IT BETTER

SPIKER

130 S. Milford Road, Milford 684-1715 or 953-6597

OPEN Monday & Thursday '88
Tuesday, Wednesday, Friday '88

GREEN SHEET WANT ADS REACH OVER 64,000 HOMES

They were man made.
By a man who burned her face and back with lit cigarettes, then threw her into the air, letting her fall to the ground until she bled from the nose and mouth. A man who did it all for the pleasure of hearing her screams of pain.

We know it's a hard story to read. It's a hard story to tell. Abuse cases always are. In this case, the abuse of a defenseless eight week old kitten named Gracie.

And as long as cases of such inconceivable cruelty exist, the Michigan Humane Society (MHS) will be there to combat them through animal rescue, cruelty investigation and prosecution.

But waging this kind of war against animal abuse takes money. Lots of it. When you give to the MHS during "Be Kind To Animals Week," or at any other time, you're helping to stop tragic situations like Gracie's from happening.

Your money helps the MHS continue its mission to put an end to animal cruelty, to further the rights of animals, and to take aggressive action against people who wrong them.

It's contributions like yours that have already helped Gracie. For the past three months she's been under the care of the MHS veterinary staff at our downtown shelter, and will soon be ready for adoption.

The man who abused her is being brought to trial on three counts of animal cruelty. If convicted he could be imprisoned for up to three months and/or fined up to \$500.

So please give generously to the Michigan Humane Society. Your donation, no matter how small, helps. And that help could stop other people from leaving their marks on defenseless animals.

Michigan Humane Society

Your contribution is tax deductible. And invaluable.

Here is my gift of \$10 \$25 \$50 \$100 other _____

Please make checks payable to: Michigan Humane Society, 7401 Chrysler Drive, Detroit, Michigan 48211.

Or charge my VISA MasterCard

Card Number _____ Exp. Date _____

Name _____

Signature _____

Address _____

City _____ State _____ Zip _____

The Michigan Humane Society is a non-profit organization funded by private contributions. MHS-228

McDONALD FORD

ON EVERY NEW CAR, TRUCK, & VAN

Sale Prices

-Plus- Rebates Up To \$3000**

Don't Be Fooled by Ads that Only Show You the Base Price
These Cars & Trucks are Loaded. Prices Include All the Options

1988 AEROSTAR CONVERSION VAN Was \$21,877 Discount \$2078 Rebate \$3010 Now \$16,549* Stock No. 78233	1988 BRONCO II Was \$16,765 Discount \$1458 Rebate \$750 Now \$13,999* Stock No. 82327	We Pledge To Give You The Edge! *Our Prices Include Every Option On The Car or Truck Presented **These Cars and Trucks Are In Stock Now For Immediate Delivery *Our Prices Include Dealer Prep *Our Inventory Is Available For Your Inspection 24 Hours A Day *Free Full Tank of Gas With Each New Car, Truck or Van Purchase *Competitive Finance Rates From People Who Live, Work, & Shop In The Same Communities You Do**	1988 FESTIVA L PLUS Was \$10,647 Discount \$1246 Rebate \$500 Now \$4,999* Stock No. 82327	1988 ESCORT Was \$12,159 Discount \$1458 Rebate \$750 Now \$8,399* Stock No. 8107
1988 E-150 CONVERSION VAN Was \$23,089 Discount \$2169 Rebate \$3000 Now \$18,399* Stock No. 78917	1988 RANGER GT Was \$15,132 Discount \$1363 Rebate \$750 Now \$11,799* 3 To Choose From	1988 TEMPO GL Was \$10,525 Discount \$1,726 Rebate \$500 Now \$8,699* Stock No. 8098	1988 ESCORT GT Was \$10,543 Discount \$1,244 Rebate \$750 Now \$8,699* 2 To Choose From	
1988 F-150 Was \$11,456 Discount \$2857 Rebate \$500 Now \$8,899* Stock No. 78920	1988 EDDIE BAUER AEROSTAR Was \$19,161 Discount \$2767 Now \$16,399* 12 To Choose From	1988 TAURUS LX Was \$18,063 Discount \$2784 Rebate \$500 Now \$13,699* Stock No. Demo 8485	1988 T-BIRD Was \$15,276 Discount \$1,977 Rebate \$750 Now \$13,199* Stock No. 8493	
1988 BRONCO Was \$21,159 Discount \$3157 Now \$17,999* Stock No. 82918	OVER 100 Trucks In Stock Including Hard To Find -Crew Cabs -Parcel Delivery Vans -Club Wagons -Super Cabs And More	1988 CROWN VICTORIA LX Was \$18,118 Discount \$2819 Now \$15,299* Stock No. 83225	Over 200 Cars In Stock Including Hard To Find •Mustangs • T-Birds • Tempos • Taurus*	

VISIT OUR NEW DISPLAY AREA AT 7 MILE & SHELDON ROADS-NORTHVILLE

McDONALD FORD

CONVENIENTLY LOCATED

349-1400

550 W. 7 Mile Road Northville

Between Northville Road & Sheldon Road
One Block East of Northville Downs
*minutes West Of I-275

THE DISCOUNT KING

CLEARANCE DISCOUNTS UP TO \$5000

OVER 1400 CARS, TRUCKS and VANS IN STOCK

FREE TANK OF GAS WITH EVERY NEW CAR OR TRUCK

8.75% Annual Percentage Rate Financing On Select Models

88 1/2 ESCORT 3-DOOR From \$5690* \$500 REBATE Plus FREE AIR CONDITIONING ON GT	'88 TEMPO 2-DOOR From \$7090* \$500 REBATE Plus \$1000 FREE OPTION PACKAGE	ATTENTION: COLLEGE GRADUATES BUY or LEASE \$400 COLLEGE REBATE -PLUS- UP TO \$1000 FACTORY CASH -PLUS- UP TO \$15,000 PRE-APPROVED CREDIT Ford Employee sons & daughters A-plan discounts also qualify	'88 TAURUS 4-DR. From \$9290* \$600 REBATE Plus \$500 FREE OPTION PACKAGE	'88 THUNDERBIRD TURBO From \$13,790* \$1076 FREE OPTION PACKAGE
'88 MUSTANG LX 2-DOOR From \$7290* \$750 REBATE Plus FREE *793 OPTION PACKAGE	'88 F-150 PICKUP From \$7890* \$500 REBATE Plus FREE AIR CONDITIONING ON XLT		'88 FESTIVA 3 DOOR From \$4990* \$300 REBATE Plus NO PRICE INCREASE-IN STOCK	'88 RANGER PICKUP From \$6090* \$500 REBATE Plus FREE \$1256 OPTION PACKAGE

'88 ECONOLINE CONVERSION EQUIPPED...NOT STRIPPED E.F.I. eng., auto, trans, p.s., p.b., air cond., am/fm stereo, cass. speed control, tilt, P225x15WSW sport wheels, full dx int., captain chairs, r. seat bed, exterior graphics, bay windows, insulation pkg., drapery pkg., Continental spare. \$13,990* 50 VAN CONVERSIONS IN STOCK	'88 AEROSTAR CONVERSION EQUIPPED...NOT STRIPPED 3.0 E.F.I. V-6 Auto. overdrive, p.s., p.b., P215x74 all-season tires, air cond., T. glass, AM-FM stereo/clock, body side moldings, styled wheels, speed control, tilt wheel, captain chairs w/7 pass. benches, fibreglass running boards, exterior graphics, clearcoat paint. Stock No. 96. \$13,490* 100 AEROSTAR VANS AND WAGONS IN STOCK
--	---

FACTORY AUTHORIZED DISCOUNT CENTER FOR

1989 PROBE NOW IN STOCK

IN STOCK SALEEN HI-PERFORMANCE MUSTANG

CAUTION: Don't Make The \$500 Mistake • Get A High Dollar Varsity Ford Trade-In • We Need Your Old Car or Truck

3480 JACKSON RD AT WAGNER PHONE 996-2300

MON. & THURS. 9 to 9, TUES., WED., FRI. 9-6, Closed Sat. June-July-August

NOBODY SELLS FOR LESS! LIFETIME SERVICE GUARANTEE

theNOV NEWS

He's a teacher, a football player, a listener, a soccer coach and a provider. He's strong, caring, witty and wise. He fixes toys, mends broken hearts and shares potato chips and candy. That special guy is Dad.

He holds our hands when we are scared, he watches television with us, he helps us with our homework, he gives us treats when Mom isn't looking and he encourages us to do our best in everything we attempt. He plans fun-filled vacations, takes us shopping or camping and even though he isn't perfect, he comes pretty darn close. He's always there when we need him... he's our Dad.

These heart-warming tidbits were taken from letters sent by area children in response to our first Father's Day Letter Contest. We asked kids of all ages to tell us what made their dads special. Although the responses varied, all of the children agreed on one conclusion — their dad was "The Best Dad In The World."

We received a whopping 143 letters from Northville and Novi kids and were faced with the extremely difficult task of choosing the best ones. Featured below are just a few of our selections. Inside this section are more letters and the names of all who entered the contest. We graciously thank all of the children who took the time to share their thoughts and experiences with us. And, Dad, Happy Father's Day.

Letter key:
 A. Heather Jahnke - age 6
 B. Tina Wild - age 5
 C. Danny Sayers - age 7
 D. Kristen Minko - age 12
 E. Bill Sayers - age 9
 F. Vincent Meenan - age 13
 G. Jennifer Ernst - age 8
 H. Stacey Pearl - age 13
 I. Sam Cole IV - age 7
 J. Marc Moran - age 13

A My daddy my daddy takes me for sled rides. He pulls fast. He tells me and my brother stores. He reads us books. He sometimes even buys me a treat. I love him my daddy. When we go camping he lets us roast marsh-melos. Yuck he catches spiders. When were at a play ground he pushes me high on a swing. He washes me slide down the slid. Hes a good paster. I hat makes him special! I sure do like my dad!

B My Dad Is The Best. He takes me out to breakfast on SATURDAY MORNINGS. And he gives time to play with me and my sister. When its my BIRTHDAY HE takes just me into town and buys me cookies candy and flowers. In the winter he takes us to his work. When it is Christmas he gets us get candy and cookies from the candy truck. We are going on an Indian Princess campout. We are going to go swimming and maybe fishing and boating. My dad is special because he loves us. This is a picture of me riding a horse with Indian Princesses.

C My dad is nice. I love my dad. He has a lot of friends. Me and my dad beat up. It is fun. Sometimes my dad gets in trouble. My dad likes suburbs. We have a suburban. When we go on vacation we take it. He wants a cabin. He wants a cabin cheap.

D Dear Sir, my dad is a real wittit guy. He doesnt keep me from doing anything. He knows is "in". My dad also wants the best for my sisters and I. My first high game was just now. Three goals from the club out. All is a great dad. Sincerely, Kristen Minko

E Why I Like my Dad I like my dad for a lot of reasons. Here are three reasons why. I like my dad because he took a day off of work. So my mom could take a day off and go with our class to Green field Village. My dad baby sat six little kids. Wasnt that nice of my dad? Another time he took me to a hockey game. The Red wings won and I was glad for two reasons. One, he took me two, they won.

F I love my dad very so. For once he understands what I say. He is a super special man. But he can't even cook with a pan. I love you DAD! STACEY

G My Dad makes me feel special. He talks to me a lot, he helps me get ready for school. He makes my breakfast and gets my lunch. He also comes my hair. He makes sure I get to my bus stop safely. He walks to the edge of our driveway and watches me run to the bus stop. That shows me he cares. He plays pretend with me. He lets me pretend when I want to. My dad to me is the best dad in the whole world. Jenny

H Dad lets my sister and I do anything we want to as long as its legal and before 8:30 p.m. on school nights. I hate another reason I like him so much because he trusts us. He trusts his kids and we trust him. I would not trade my dad for anything else. He is just plain cool. He really knows what is happening. I really dont know how he knows so much. I love my dad more than anything in the world. Thats the truth, thats one thing I wouldnt lie about. Sincerely, mard moran

I I like when my dad plays soccer with me. Because I always win. I like when my dad throws me in the pool and swings me on the swing.

J My dad is a pretty special guy when he is in a good mood. When he gets in a bad mood, look out. I usually find a place to retreat to. I hate when he is in a bad mood because of something I did or my sister did. It is looks like I made my parakeet fall off his perch, or make my dog howl when he yells at us kids.

Dollar Days!

DELICIOUS

- Elite Wafers 2.12-OZ. PKG.
- ASSORTED FLAVORS
- Borden Lowfat Yogurt 8-OZ. CUP
- VARIETIES, FROZEN
- Marquez Burritos 5 VARIETIES, FROZEN
- Frozen Waffles 5-OZ. PKG.
- FARM-MAID
- Morton Cheesecakes 3.5-OZ. PKG.
- ASSORTED, FROZEN
- OZARK VALLEY CHICKEN OR TURKEY
- Frozen Meat Pies 7-OZ. PKG.
- ASSORTED
- 9 Lives Cat Food 6-OZ. CAN
- ASSORTED FRUIT FLAVORS
- Jiffy Muffin Mix 7-OZ. BOX
- THRIFTY FARM
- Cut Green Beans 15 1/2-OZ. CAN

FOR

- MOTT'S ASSORTED Apple Sauce 4-OZ. CUP
- HUNT'S Tomato Sauce 8-OZ. CAN
- PRINCE DINNER Macaroni & Cheese 7 1/2-OZ. BOX
- QUICK TIME Pork and Beans 16-OZ. CAN
- STRAINED FRUIT & VEGETABLES Heinz Baby Foods 4 1/2-OZ. JAR
- TOWN PRIDE Cut Red Beets 16-OZ. CAN
- DEL MONTE Tomato Paste 6-OZ. CAN
- MCMILLIN'S ASSORTED Lunch Box Pies 4-OZ. PKG.

MINUTE MAID 100% PURE
Orange Juice
\$2.88
96-OZ. JUG

PARTY TIME FROZEN
Twin Pops
\$1.18
18-CT. VARIETY PACK

JUMBO 12 SIZE
Cantaloupe
88¢ EA.



FARMER JACK'S
All Beef Hamburger
ANY SIZE PKG.
98¢
LB.
TYSON GRADE A • 3 BREASTS • 3 DRUMS • 3 THIGHS

Pick-Of-The Chicken
ANY SIZE PKG.
97¢
LB.

FARMER JACK SUPERMARKETS

FARM MAID
2% Lowfat Milk
\$1.35
GAL. PLASTIC

MAMA LAROSA'S ITALIAN STYLE
Frozen Pizza
• PEPPERONI 7-OZ. • DELUXE 8-OZ.
EA. PKG. **99¢**
MICROWAVEABLE

REG. OR DIET SPRITE, SQUIRT, MINUTE MAID ORANGE, DR. PEPPER, CLASSIC, CHERRY OR
Coca-Cola
2-LITER BTL. **89¢** PLUS DEP.

the NOVI NEWS Sports

HIGH HOPES: Cabana coach hopeful as summer season begins/2D

LATE SURGE: Strong finish buoys hopes of soccer squad/4D

LOOKING AHEAD: Ladycat thinclads to build with underclassmen/3D

SMART SNACKS: Hints for parents on nutritious snacking/6D

1D
THURSDAY
June 16, 1988

All-Area nine glitters like gold



The 1988 edition of the Sliger/Livingston East All-Area Softball team — shown above at McMartin's Jewelry in Milford — is certainly a formidable bunch. We call them the "Queens of the Diamond" because they shined brightly for their respective teams throughout the season. The first team (above, left to right) includes Angel Ianni of Novi; Sheila Hatton and Kim Shanks of South Lyon; Laurie Emme and Michelle Davis of Milford; Michelle Benner, Karen Grace and Kelly Forbis of Lakeland. Northville's Amy Freimund and Nanci Dutkiewicz are not pictured. Every team in the area sported a winning record and these players are the stars from those teams. We're sure you'll agree this group is solid gold.

Novi's Angel Ianni anchors third-base position

All five softball teams in the Sliger/Livingston East area sported winning records during the '88 campaign... and it wasn't just a coincidence. Very talented players made the difference and there was certainly an abundance of them — as our 1988 All-Area Softball Squad can attest. Without further delay, here's the first team...

KELLY FORBIS, Lakeland, pitcher: This junior righthander was 26-6 for the Eagles, who tied Hartland for first place in the Kensington Valley Conference. "Kelly, without a doubt, is our most valuable player," Coach Kent Griffiths said. "She's had two great years in a row. When you have a pitcher like her, you're automatically in every game no matter who you're playing." A 5'11" righthander, Forbis struck out 187 batters in 202 innings and recorded a 1.31 ERA. She allowed only 146 hits, 43 walks and 38 earned runs. Offensively, the Eagle star posted a .212 average with eight extra-base hits — three doubles, four triples and one home run. "She's outstanding," Griffiths added. "She throws hard, her control is good and she has an excellent changeup. Pitching is the key to softball and Kelly gives us an advantage over most teams."

AMY FREIMUND, Northville, pitcher: This junior had a whole arsenal of pitches and used them to become the most dominating hurler in the W.L.A.A. Her record on the season was a sparkling 15-3 with an even more impressive 1.23 ERA. She had five one-hitters during the season and allowed just one earned run in her final eight regular-season games. In 97 innings of work, Freimund fanned 115 and walked only 36. Opposing hitters had a combined batting average of .140. "Amy was on a mission this year and I don't think anybody can deny she had a fabulous season," Mustangs coach Bob Gerlach said. "The velocity of her pitches was good, but that's not really her strength. It was smartness. "You don't see many girls throwing pitches like changeups and she wasn't afraid to throw it with a full count on a batter. She used a knuckle-curve and other unique pitches, and she seemed to do whatever she wanted with the batters." Freimund also led Northville in hitting with a .349 average and a .569 on-base percentage.

SHEILA HATTON, South Lyon, catcher: This junior was South Lyon's defensive enforcer, both with her glove and powerful right arm. "Sheila did a tremendous job behind the plate," Lions coach Amy Poljan said. "She calls a good game, and she instructs and leads very well. She also learned to handle low and outside pitches a lot better." "But her real asset back there is her arm. She throws the ball hard and accurate, so she's able to keep the runners close. She really helps our infield."

Hatton picked off 23 runners and ratted down all but two would-be base stealers this season. Offensively, she recorded a .318 batting average and .494 slugging percentage. She also totaled five doubles, three triples and 15 runs.

MICHELE BENNER, Lakeland, infielder: This senior shortstop led the area with a .402 batting average. She also collected nine doubles, four triples, one home run and 31 RBIs. "There's not much Michele can't do," Coach Kent Griffiths said. "She has a great arm and she's a great hitter. Her hands are soft, too, so they give with the ball. She has a lot of tools that you can't teach a kid." Benner, a four-year varsity player who was an outfielder as a freshman and a pitcher as a sophomore, struck out only four times in 112 official plate appearances. She also recorded 11 stolen bases, a .545 on-base average and a .608 slugging percentage. Defensively, she handled 90 of 101 chances successfully.

MICHELLE DAVIS, Milford, infielder: This senior was forced out of her normal first base position early in the season when the Redskins experienced problems on the left side of their infield. "Michelle was a versatile player for us," Coach Chuck Vereecke said. "We needed her to step in and do the job, and that's exactly what she did." "The only problem was that moving back and forth between third and shortstop seemed to affect her hitting. So we decided to put her at short and leave her there. It worked, too, because she came on offensively the second half of the season." Davis hit .368 with 17 runs, six doubles, one triple and 22 RBIs. She made nine errors defensively.

KAREN GRACE, Lakeland, infielder: This powerful junior hit the ball harder and farther than any player in the area. Her season totals include four doubles, four triples and three home runs. According to Eagles coach Kent Griffiths, some people overlook her defensive skills. "Karen brings quality to first base," he commented. "She really worked on picking up those shorts hops this year, so I never had to worry about balls getting past her. To be honest, she probably made more improvements defensively than offensively." Grace committed only five errors in 229 chances for a .378 fielding percentage. Offensively, she hit .352 and recorded a .513 on-base average. She also scored 31 runs, knocked in 24 and stole 14 bases.

ANGEL IANNI, Novi, infielder: When the Wildcats played a big hit

McCarthy, Kasten head 2nd team

Here is the 1988 Sliger/Livingston East All-Area Softball Second Team...

LORI CARTER, Milford, pitcher: This hard-throwing senior rebounded from a dismal junior year to win 11 of 17 decisions and toss four no-hitters. A righthander, Carter recorded a 3.65 ERA in 103 innings of work. "Lori started a lot stronger than she finished, but she had some nagging injuries at the end of the season," Coach Chuck Vereecke said. "I'm amazed by her, though. She came a long way after what happened last year. A lot of kids would have hung it up, but Lori worked and worked in the off-season to correct her control problems."

LISA MCCARTHY, Novi, catcher: McCarthy will go down as one of the most talented two-sport stars in Novi history. In addition to excelling on the basketball court, this senior has been a premier catcher for years and this season she added pitching to her already long list of accomplishments. Her batting average dipped a bit, but she was still above .300 and led the Wildcats in runs scored (36), walks (17) and on-base percentage (.511). "Her average might have been down a little, but Lisa did a lot of great things for us," Coach John Peace said. "She stroked the ball well this year, but she didn't get many breaks. She may have been trying a little too hard as well." "We used her as a pitcher quite a bit, and during the second half of the season, she was concentrating on that and I think it hurt her offensively." McCarthy plans to attend Alma College next fall and will play both basketball and softball.

LISA WALTERS, South Lyon, pitcher: This senior righthander, lost in Andrea Nelson's shadow a year ago, emerged as South Lyon's ace during the second half of the season en route to a 9-6 record. "Lisa was a stable pitcher," Lions coach Amy Poljan said. "Her main pitch is the fastball, but her changeup came along real well. She also worked the corners better as the season went on." The highlight of Walters' season came in late May at the prestigious Ann Arbor News Tournament. She led the Lions into the playoff round and was named to the all-tournament team. Walters batted only .37 times, but hit .351 with one double and one triple. "I wish I would have had the insight to bat her more," Poljan said.

LISA MCCARTHY, Novi, catcher: McCarthy will go down as one of the most talented two-sport stars in Novi history. In addition to excelling on the basketball court, this senior has been a premier catcher for years and this season she added pitching to her already long list of accomplishments. Her batting average dipped a bit, but she was still above .300 and led the Wildcats in runs scored (36), walks (17) and on-base percentage (.511). "Her average might have been down a little, but Lisa did a lot of great things for us," Coach John Peace said. "She stroked the ball well this year, but she didn't get many breaks. She may have been trying a little too hard as well." "We used her as a pitcher quite a bit, and during the second half of the season, she was concentrating on that and I think it hurt her offensively." McCarthy plans to attend Alma College next fall and will play both basketball and softball.

JEANINE LAPRAD, Northville, infielder: LaPrad made the switch from shortstop to second base this season, and the move worked. The senior had a solid season, and as a result, is the only Northville player ever to garner W.L.A.A. All-Division honors at two different positions. She batted .250 for the year, but had big numbers in key league games against Livonia Franklin, Plymouth Canton and Farmington Harrison (15-for-25 combined). LaPrad fanned just four times in 57 at-bats, had an on-base percentage of .491, a slugging percentage of .642 and 10 RBIs. "Jeanine made a sacrifice for the good of the team and she proved to be just as outstanding at second base," Coach Bob Gerlach said. "She's an outstanding fielder and she's always ready to play. She's ready the night before, especially the big games."

RENEE RUSS, Lakeland, infielder: This versatile senior hit .377, stole 15 bases and worked opposing pitchers for 30 walks. "This is one kid we'll really miss," Coach Kent Griffiths said. "She does so many things that don't show up in the scorebook, like laying down a key bunt or playing out of position from time to time." A second baseman last season, Russ spent most of the 1988 campaign at the hot corner. Her defensive statistics include 49 assists, 37 putouts and seven errors. With the bat, she added four doubles, one triple, one home run,

PLAYER OF THE YEAR: Kelly Forbis, Lakeland.
COACH OF THE YEAR: Bob Gerlach, Northville.

HONORABLE MENTION: Cory Kincer, Kerri Bulin — Northville; Stacy White — Lakeland; Lynn Brinkman, Lori Monte, Shannon Pingston — Milford; Tricia Eisinger — South Lyon; LAURA CASE, JENNIFER NAMETH, MARY MARCUS — Novi.

SmartSmart™ is for informational purposes only and not for the purpose of giving medical advice or consultation for any specific condition. Copyright 1986 Henry Ford Health and Vasculin Institute. Prices effective through Sunday, June 19. We reserve the right to limit quantities to specified amounts. No sales to dealers, restaurants or institutions.

BUILDERS SQUARE®

HOME IMPROVEMENT WAREHOUSE

Father's Day Special

EXPERT
ADVICE...
COME
TALK TO
US!

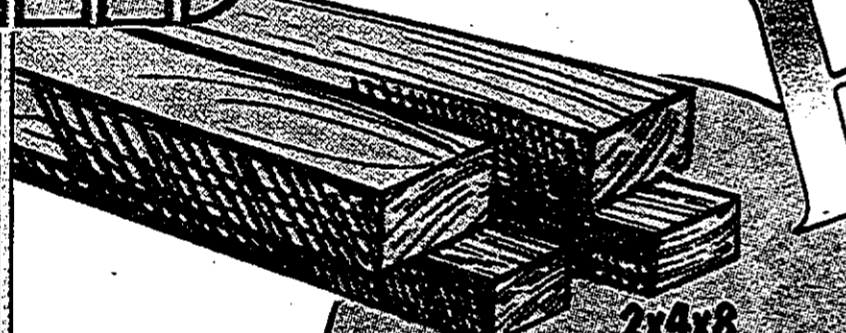

**2x4x8
WHITWOOD
STUDS**
139

- Kiln-dried.
- Stud grade.

JUNE SALE DATE

SUN	MON	TUE	WED	THU	FRI	SAT
			15	16	17	18
19	20	21				



**TRUK
MATE™**

**WILL
NOT
RUST**

\$69

- Keeps tools or recreational gear clean, dry and within easy reach.
- Resists chemicals, fuels and salt spray.



**4-FOOT
SHOPLIGHT**

\$8

**BULBS
NOT
INCLUDED**

**GREAT
BUY!**

- A must for any shop.
- Grounded cord.
- Uses two 4-ft. bulbs. (Not included)

**Sunbeam
30,000 BTU
GAS GRILL**

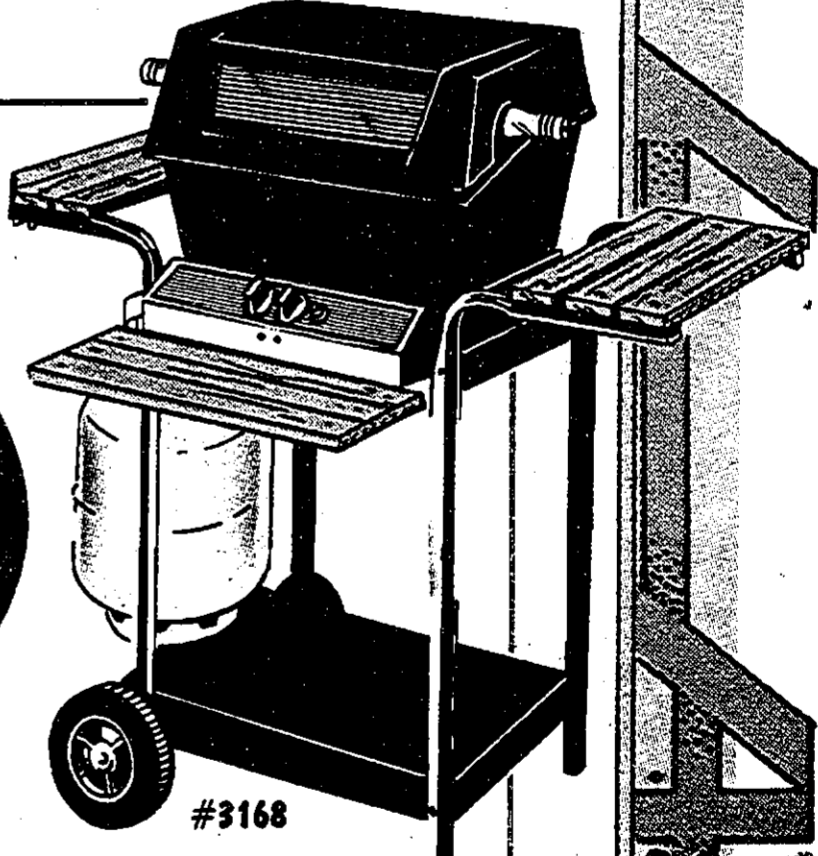
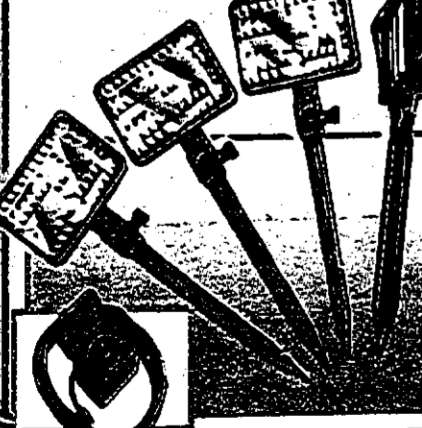
**INTERMATIC
MALIBU**

- Installs in minutes with no more than a screwdriver.
- Brightens sides of home.
- Great for walkways, pool or patio.

**OUR
LOW
PRICE** **\$32**

**LESS MFR.
REBATE** **-\$4**

**YOUR
FINAL COST** **\$28**

**12-2 NON-METALLIC
BUILDING
WIRE**

\$26

25' CARTON 12-2 UF/W6 #35

STANLEY



**CONCRETE
MIX** **27**

**12" STANLEY
POWERLOCK** **28**

#33-212

HAND HELD **\$22**

#SM-3U **#SM-2U**

CONTRACTOR QUALITY LUMBER AT LOW WAREHOUSE PRICES!

BUY WHERE THE BUILDERS BUY!



AGENCY APPROVED

3/8-INCH CDX PLYWOOD
715
4'x8'
SKU# 0260018

CONTRACTOR PRICES!

1/2"	7.39	4'x8'
5/8"	11.55	4'x8'
3/4"	14.35	4'x8'

• A versatile plywood.

WHITE WOOD SHORT LENGTH APPEARANCE BOARDS

118

SIZE	6'	8'
1x4	1.18	1.54
1x6	1.98	2.68
1x8	2.63	3.42
1x10	3.45	4.44
1x12	4.66	5.86

1"x 4" - 6-Foot

#3 WHITEWOOD BOARDS

170

SIZE	10'	12'	14'	16'
1x4	1.70	1.99	2.38	2.72
1x6	2.70	3.24	3.78	4.32
1x8	3.60	4.32	5.04	5.76
1x10	4.60	5.52	6.44	7.36
1x12	5.53	6.64	7.74	8.65

1"x 4" - 10 Foot

NO MIDDLEMAN MARK UP!

3/4-INCH THICK WIDE PINE BOARDS

SIZE	36"	48"	72"
15"	7 ⁹⁶	9 ⁹⁶	14 ⁹⁶
18"	9 ⁸⁷	12 ³²	17 ⁸⁴
24"	12 ⁷⁴	16 ⁶⁸	22 ⁹⁹



BCX PLYWOOD 4'x8' Plywood siding

3/8"	11 ¹⁹	4'x8'
1/2"	13 ³³	4'x8'
3/4"	16 ⁷³	4'x8'

3/8" T-4" O.C. 996
4'x8' SHEET

5/8" T-4" o.c.	13 ⁹⁹	4'x8'
5/8" T-8" o.c.	13 ⁹⁹	4'x8'
5/8" RBB 12" o.c.	14 ⁷⁵	4'x8'

INDUSTRIAL QUALITY TOOLS... THAT PROFESSIONALS PREFER!

Makita POWER TOOLS!

3/8" VARIABLE SPEED REVERSIBLE DRILL
\$44
#M601

- Powerful motor, balanced, lightweight, cuts operator fatigue.
- Reversing lever and locking button are conveniently located for easy one handed operation.
- Double insulated for operator safety.

7 1/4" CIRCULAR SAW
\$87
#M513

- Heavy duty hi-tech motor cuts 2 3/8" at 90° and 1 1/2" at 45°
- Balanced for better control and ease of operation.
- Ball and needle bearing construction for durability. Easy blade replacement; double insulated for operator safety.

Makita FINISHING SANDER

\$37
#M901

- Lightweight, powerful, fits into the palm of your hand.
- Square design allows flush sanding on all sides for reaching corners.
- May be used for removing paint, refinishing furniture, smoothing rough edges on wood and metal. Has many other uses.

BLACK & DECKER QUALITY

9" POWER MITRE SAW
\$120
#7715

- 2 h.p. ball & sleeve bearing motor.
- Gear driven blade.
- Table rotates with cutting blade.
- Includes 9" combination blade wrench.

1 1/4 H.P. ROUTER
\$45
#7613

- 8.5 amp, 25,000 RPM motor.
- Ball bearing construction.
- Spindle lock - only one wrench needed.

19-INCH TOOL BOX
644
19"x7"x7" liftout tray.

- 19"x7"x7", red baked enamel finish.
- One-piece steel construction, plastic liftout tray.

20-INCH HIP ROOF BOX
\$16

- Lift out plastic tote tray featuring socket snuggler.
- Sturdy plated handle, lockable latch.
- Solid steel construction.

3/8" CORDLESS DRILL
\$29
#9020

- Two speeds let you pick the speed to suit the job.
- Reversible for backing out screws and jammed drill bits.
- Comes complete with a 16 hour recharger.
- Full two-year home use warranty.

3/8" REVERSIBLE HIGH-TORQUE DRILL KIT
\$89
#1910-1

- Compact design for more comfortable use.
- 65 watt DC motor delivers high torque.
- One hour recharger for fast charging of Energy Pack.
- Overload circuit breaker protects motor.

Disston ACCESSORIES

5-PIECE MASONRY DRILL SET
528

- Carbide tipped drills for drilling brick, plaster, concrete, tile & slate.

10-PIECE DRILL BIT SET
566
#5516

7-PIECE INSERT BIT SET
644

- Insert bit set includes #1, #2, #3 Phillips.
- #6-8, #8-10, #10-12 Slotted bits and 1/4" hex shank.

**WE'RE YOUR #1 DOOR STORE...
LOWEST PRICES GUARANTEED!**

**2-BAR
SCREEN
DOOR**
18⁵⁷

- Constructed from sugar pine wood with a natural finish.
- Charcoal fiberglass screen.
- Hardware sold separately.

WOOD

**32-IN. OR 36-IN.
WOODEN SCREEN DOORS**

A. 3-BAR 28⁹⁵
• Extra sturdy standard door.
• Installs easily.
• Resists wear.

B. 3-PANEL 38⁸⁸
• Constructed from hem-fir with a natural finish.
• Charcoal fiberglass screen.

**REPLACEMENT
GRILL**
9⁷⁷

30-IN. GRAY 11.26
30-IN. BRONZE 11.26
36-IN. BRONZE 13.96

AVAILABLE
IN
30" or 36"
WIDTHS

STANLEY
**SCREEN & STORM
DOOR SET
WITH SPRING**

5³² #1750
• Everything needed to hang and equip a screen door.

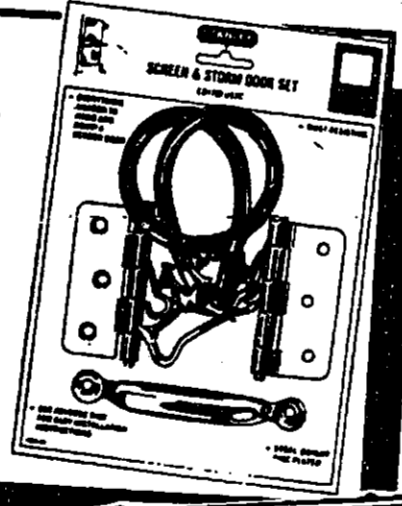

**SOLID WOOD CORE
STORM DOORS**

<p>LARSON VALUE CORE STORM DOOR \$118 #280 SERIES</p> <ul style="list-style-type: none"> • Maintenance-free aluminum surface. • Safety glass window positions for top ventilation. <p>32" x 80" or 36" x 80" WHITE or BROWN</p>	<p>LARSON LIFE-CORE FULITE STORM DOOR \$170 #240 SERIES</p> <ul style="list-style-type: none"> • Solid wood core construction. • All seamless aluminum surface. • Rugged hinges, safety glass. <p>32" x 80" or 36" x 80" WHITE or BROWN</p>	<p>LARSON MAGNA-CORE CROSSBUCK STORM DOOR \$199 #230 SERIES</p> <ul style="list-style-type: none"> • Seamless aluminum surface. • Solid wood core construction. • Safety-glass window adjusts to different positions. <p>32" x 80" or 36" x 80" WHITE or BROWN</p>
--	---	--

**30" SLIDING
PATIO
SCREEN
DOOR**
25⁴⁷

BRONZE OR GRAY
• Fiberglass screening with baked enamel steel frame.
• Quiet, smooth roller assemblies and automatic self-latching mechanism for trouble-free operation.

36-INCH 27.47

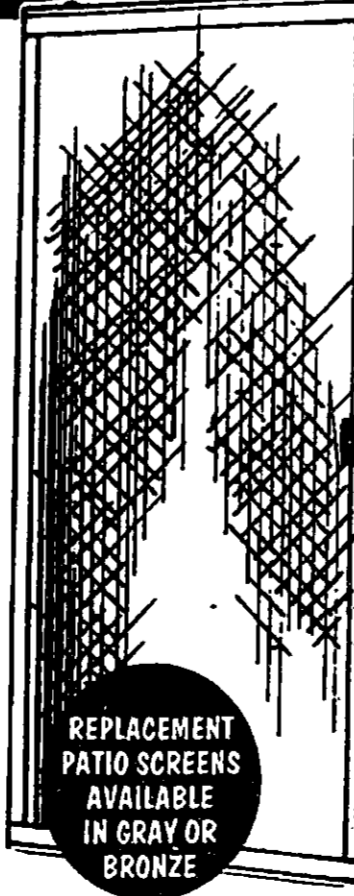

**REPLACEMENT
PATIO SCREENS
AVAILABLE
IN GRAY OR
BRONZE**

**INTERIOR DOORS AT THE
LOWEST PRICES GUARANTEED!**

SCHLAGE LOCKS

STYLE	PASSAGE	PRIVACY
BELL	8 ⁹⁶ BRIGHT BRASS	10 ⁹⁶ BRIGHT BRASS
GEORGIAN	11 ⁴⁵ ANTIQUE BRASS	12 ⁹⁶ ANTIQUE BRASS
PLYMOUTH	8 ⁹⁶ BRIGHT BRASS	10 ⁹⁶ BRIGHT BRASS
ORBIT	11 ⁴⁵ BRIGHT BRASS	12 ⁹⁶ BRIGHT BRASS
	12 ⁹⁶ * ANTIQUE BRASS	13 ⁹⁶ * ANTIQUE BRASS

**24-INCH
LAUAN
PREHUNG
DOOR**
28⁴⁵

- The perfect door for new construction.
- Takes the work out of new door installation.
- Pre-bored hole for door knob.

30-INCH 30.30
32-INCH 31.24
36-INCH 31.40

**24-INCH
COLONIST
6-PANEL
DOOR**
25⁶⁶

- Rich, warm look of wood.
- Hollow core construction.
- 1 3/8" thick.

30-INCH 27.24
32-INCH 28.74
36-INCH 30.57

**PRIMED AND
READY TO PAINT**

INSTALL IT!
EXTERIOR WOOD DOOR
\$98
and it's GUARANTEED!

**#66
24-INCH
SELECT GRADE
6-PANEL
FIR DOOR**
\$73

- Selected vertical grain douglas fir.
- Solid raised panels.
- 1 3/8" thick.

28-INCH \$75
30-INCH \$76
32-INCH \$78
36-INCH \$79

**Monarch
WARDROBE MIRROR DOORS**



**4-FOOT
GOLD
FRAME**

\$59

- Helps room look lighter, brighter and bigger.
- Elegant gold frame.

5-FOOT \$72 6-FOOT \$85

**24-INCH
BI FOLD**
\$65

- Frameless mirrors, an elegant replacement for worn or unfinished wardrobe doors.

30-INCH \$79
36-INCH \$92

QUALITY BIFOLD DOORS

<p>WING 24-INCH 1/2 LOUVER 1/2 PANEL 35⁷⁷</p> <ul style="list-style-type: none"> • An attractive addition to any home. • Provides privacy and allows ample ventilation. <p>30-INCH 42¹⁹ 32-INCH 46⁴⁸ 36-INCH 50⁷⁶</p>	<p>WING 24-INCH DOVER \$55</p> <ul style="list-style-type: none"> • Beautifully etched tempered glass inserts. • Complete with hardware. <p>30-INCH \$68 32-INCH \$70 36-INCH \$75</p>	<p>WING 24-INCH WATERFORD \$85</p> <ul style="list-style-type: none"> • Frosted, etched glass inserts. • Available in three popular sizes. <p>30-INCH \$105 36-INCH \$118</p>
--	---	--

YOUR LAWN & GARDEN NEEDS
 HERE AT BUILDERS SQUARE!

#WB-25



IMPULSE SPRINKLER
15.44

GREAT BUY!

#RB95



RAIN-BIRD SPRINKLERS
5.44 OSCILLATING

- Water "dances" for remarkably uniform coverage.
- Power jet nozzles provide precision stream control.
- Operates even at low water pressure.

#RB95

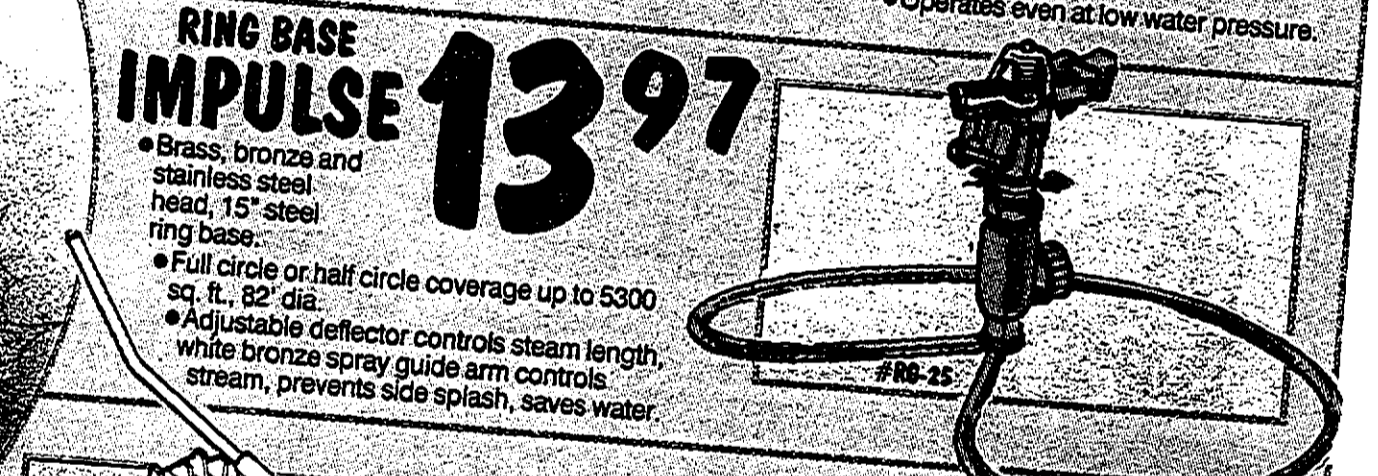

RING BASE IMPULSE
13.97

- Brass, bronze and stainless steel head, 15" steel ring base.
- Full circle or half circle coverage up to 5300 sq. ft., 82" dia.
- Adjustable deflector controls stream length, white bronze spray guide arm controls stream, prevents side splash, saves water.

#T-0-C

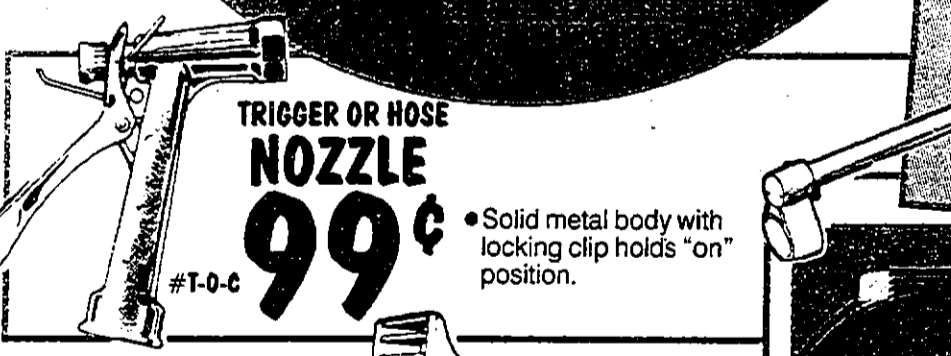

TRIGGER OR HOSE NOZZLE
99¢

- Solid metal body with locking clip holds "on" position.

#T-15-C

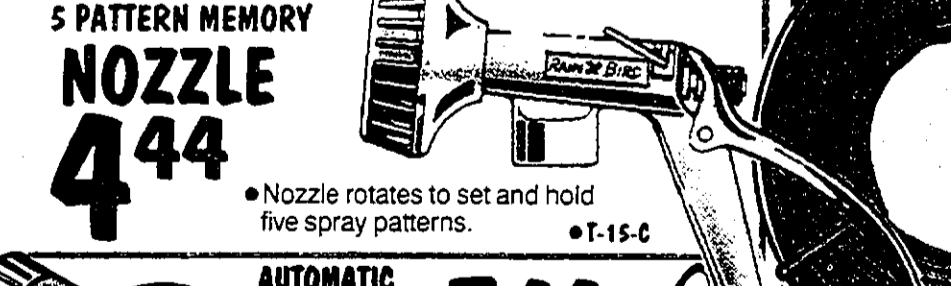

5 PATTERN MEMORY NOZZLE
4.44

- Nozzle rotates to set and hold five spray patterns.

#WT-1800

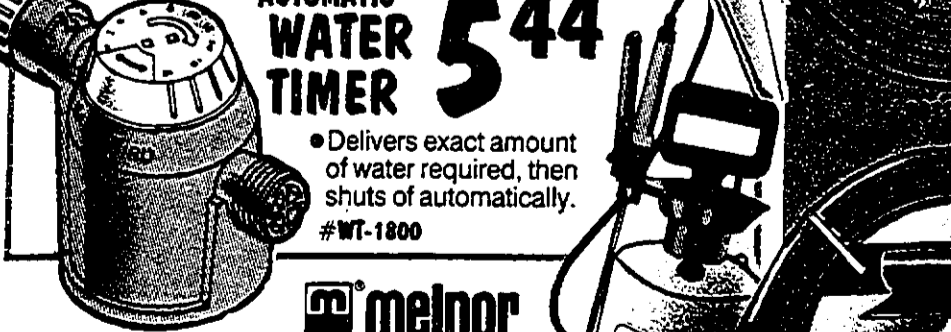

AUTOMATIC WATER TIMER
5.44

- Delivers exact amount of water required, then shuts off automatically.

#292



THREE GALLON SPRAYER
17.88

- Heavy-duty polyethylene tank with safety vent.
- Funnel top and pouring spout.

#T320



TRAVELING SPRINKLER WITH SHUTOFF
2.29

- Automatically travels up to 75 feet across your lawn.
- Waters evenly.
- Includes shutoff - traveler stops and water turns off automatically.
- Heavy-duty construction with precision spray nozzles.

#B9650-60



50-FT., 3 TUBE SPRINKLER/SOAKER HOSE
4.44

- For watering or soaking small areas.
- Sprinkles evenly at all water pressures.

#B9650-60



"RADIAL BELT" GARDEN HOSE
 OUR LOW PRICE LESS MFG. REBATE YOUR FINAL COST **7.97**
 5/8" x 60 FT. **2**
 5.97

• Double reinforced rubber/vinyl.

WE GUARANTEE LOWEST PRICES

LAWN KEEPER MOWERS

CAN OF ENGINE OIL PACKED FREE IN EACH CARTON

#BS-62 **22-INCH 4 H.P. POWER PROPELLED** **\$227**
 • Gear drive power-propelled mower.
 • 4 hp briggs & Stratton "MAX" engine.

#BSM63 **4-HP HIGH WHEEL** **\$237**
 • 4-HP Briggs & Stratton "MAX" engine.
 • 16" spoked rear wheels help in areas with high grass & weeds and in areas that are soft, sandy or uneven and hilly.

#BS70 **22-INCH 4 H.P. GEAR DRIVE** **\$244**
 • 4 HP Briggs & Stratton "MAX" engine.
 • Gear-drive power propelled mechanism provides better traction.
 • Rear discharge grass catcher empties easily.

#BS122 **LAWN KEEPER 22-INCH PUSH MOWER** **\$119**
 • 22" cut, side discharge mower.
 • Deluxe height adjusters
 • 3.5 HP - 4 cycle engine.
 • 7" poly & rubber wheels.

#PB90 **PARAMOUNT ELECTRIC POWER BLOWER** **\$24**
 • 1/2 H.P. electric motor.
 • Blows leaves, litter and debris for faster, easier outdoor clean up.
 • Clean with a powerful blast of air.

TRIMMERS

#82210 **10-INCH BUMP FEED** **\$24**
 • Adjustable auxiliary handle for better control.
 • Well-balanced, easy to use.

#1400 **14" INCH DELUXE CUT** **\$39**
 • Powerful 3.8 Amp 1/2 HP Permanent Magnet Motor.
 • Bump Feed, semi-automatic line advance.

#B-1600 **16 INCH TRIMMER WITH EDGER WHEEL** **\$44**
 • Edge guide wheel turns trimmer into a neat cutting edger in one easy move.
 • The wheel just slides out and clicks into place.
 • 16" cut.

#EB-1 **GAS STRING** **\$76**
 • 21.2cc McCulloch engine.
 • Electronic ignition.
 • Large fuel capacity.
 • Limit one rebate household.

50 FT. OUTDOOR EXTENSION CORD **10.96**
 • 14 ga. 3-conductor vinyl cord.
 • Rated for 15 amps.
 OUR LOW PRICE LESS MFG. REBATE YOUR FINAL COST **7.96**

#B-251736 **LAWN KEEPER 16-INCH TRIMMER** **\$49**

#B-251736 **LAWN KEEPER 16-INCH TRIMMER** **\$127**

WE'LL SAVE YOU MONEY FROM THE TOP DOWN!!

1 3/4" ROOFING NAILS \$23
50 LBS.
7" ROOF BRUSH WITH HANDLE 374

ROLL ROOFING 1095

- 1 roll covers approximately 100 sq. ft.
- Available in several popular colors.

ALUMINUM AND GALVANIZED FLASHING ALUMINUM

14"x10' 650
20"x10' 875

GALVANIZED

6"x10' 295 10"x10' 419 14"x10' 545 20"x10' 729
8"x10' 359 12"x10' 485 18"x10' 672 24"x10' 869

5"x10' ALUMINUM GUTTERS 396

- Your choice of white or brown.
- We carry a complete line of gutter accessories.

5"x10' VINYL GUTTER 325

- All-weather gutter system.
- Strong, durable - won't scratch or dent.
- Never rusts, rots or corrodes - never needs painting.
- Snaps on tight...won't leak.

KELLER ALUMINUM TYPE III EXTENSION LADDER \$39

- Household duty extension ladder.
- Features spring activated solid aluminum extruded rung locks.
- 2 1/2" modified "I" beam rail with full single interlock.

20-FT \$79
24-FT \$89
28-FT \$144
32-FT \$165

WHITE FIBERGLASS ROOFING PANELS 195

- Beautiful, functional panels for patio covers, carports, greenhouses and many other projects.

SIZE/TYPE	8FT	10FT	12FT
PLAIN WHITE	3.35	4.25	4.95
CLEAR, GREEN OR WHITE TEXTURED	6.95	8.75	10.45
BROWN OR WHITE RIBBED*	6.75	8.35	9.95

ROOFING PRODUCTS



MOBILE HOME ALUMINUM ROOF COATING

485

5 GALLON 22.95



ALL PURPOSE ALUMINUM ROOF COATING

685

5 GALLON 31.50



FIX-A-LEAK PLASTIC ROOF CEMENT

225

5 GALLON 10.95



PREMIUM ALL-WEATHER PLASTIC ROOF CEMENT

325

5 GALLON 13.75

R-11 KRAFT-FACED INSULATION 995

3 1/2"x15" ROLL

THAT'S ONLY 11¢ SQ. FT.

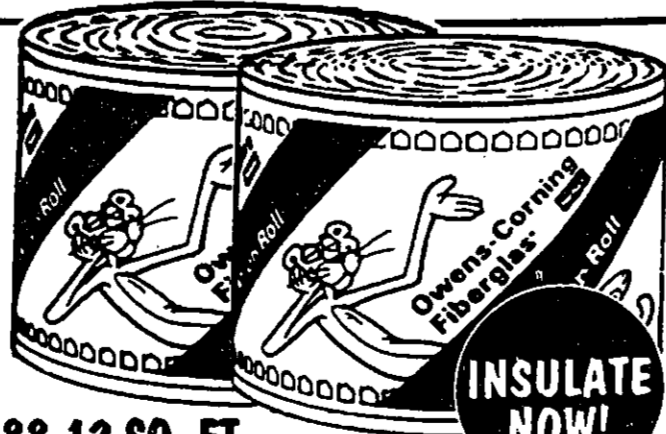

- Watch your utility bills drop with better insulation.
- Savings vary: Higher R-values mean greater insulating power.

ALL YOUR PAINTING NEEDS UNDER ONE ROOF!!

SPRED HOUSE PAINT SATIN OR GLOSS FINISH

1199 GALLON

- A. Extra durable acrylic satin latex enamel.
- B. Highly durable acrylic latex exterior enamel.

ACRYLIC LATEX CAULK WITH SILICONE 147

- Superior quality interior/exterior caulk.
- Moisture and mildew resistant.
- Paintable, easy clean up.
- 20-year guarantee.
- Available in clear, white, or colors.

SILICONE II SEALANT 347

- Use to seal windows and doors.
- Superior adhesion to woods, metals, concrete, and masonry.
- Paintable.
- Available in white and natural.

HEAVY DUTY POWER PAINTER \$86

- Lightweight sprayer for heavy weight jobs.
- Ideal for houses, garages, decks, fences.

PAINT-N-STAIN VINYL GLOVES 72¢

- 6 Gloves per package.
- Lightweight, Tough, Disposable.

WEATHER WARRIOR™ WOOD RESTORER 799

- An amazing new product that restores wood back to its rich natural color in one easy application.
- Guards against fungus and mildew attack for up to one year.

5-GALLON \$34

3M DRYWALL SANDING SCREEN 199

- Open screen resists clogging.

THOMPSON'S WATER SEAL STAINS \$10

- Durable wood stains for all exterior wood and previously stained surfaces.
- Serves as wood preservative and water repellent.

5-GALLON \$46

BULLS EYE 1-2-3 PRIMER SEALER 1299

- Acrylic latex undercoater performs 3 functions: primes, seals, kills stains.
- For use on all types of exterior and interior surfaces.
- Use on previously painted or new work.

WOODLIFE® WOOD PRESERVATIVE 697

- Protects against mildew, decay, rot and fungal stain.
- Can be painted, stained or finished.

RUST-OLEUM INDUSTRIAL ENAMEL 1599

- Tough, rust preventive, long-lasting formula.
- Quick, easy 1-coat application.
- Available in a variety of colors.

KRYLON DECORATOR SPRAY PAINT 188

- Gives small jobs a professional look.
- No-mess, quick-drying interior/exterior paint.
- Choose from a wide variety of decorator colors.

PARKS PAINT THINNER 183

- 100% mineral spirit thinner.
- Economical clean air solvent.
- 1-gallon size.

2-INCH WEATHER SEALER BRUSH 199

- Designed for the application of interior and exterior weather sealing products.

4-INCH 3.88

BRIGHTEN YOUR LIFE WITH THESE WAREHOUSE SAVINGS!

Edison. WHITE ROUND BACK OR STEP CYLINDER TRACK LIGHTING FIXTURES

\$9 EACH

YOUR CHOICE

- Concentrate light where you need it.
- Ideal for interior decorating-work areas, lobbies, etc.
- Heads are movable along track - direct light where you want it.
- Other styles available.

HOME-VUE RECESSED LIGHTING

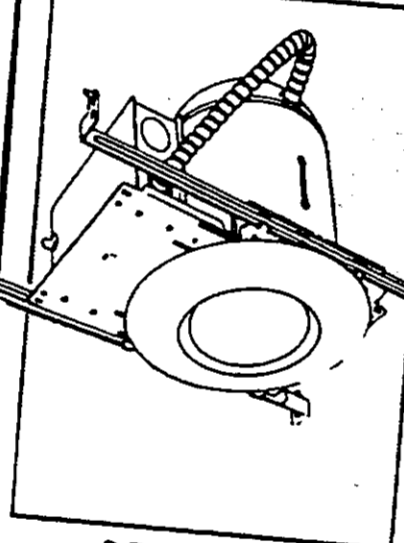

100 WATT SQUARE \$18
 • 100 watt fixture designed for suspended ceilings.
 • Pre-wired for easy installation.
 • Housing, lens, trim and bar hanging included.

150 WATT.....\$27

BLACK BAFFLE \$19
 • Create mood and atmosphere while providing efficient lighting.
 • Black baffle concentrates light and eliminates glare.
 • 150 watt rated.

INSULATED CEILING.....\$21

FLUSH LENS \$21
 • Create mood and atmosphere while providing efficient lighting.
 • Designed to provide high light output with minimal glare.

DROP LENS/SHOWER.....\$21

ADJUSTABLE "EYEBALL" \$22
 • Directional lighting for walls, pictures, or corners.
 • Use one 75 watt reflector bulb (not included).

INSULATED CEILING.....\$24

OPEN TRIM REFLECTOR RECESSED LIGHT

\$16

- Great for general room illumination.
- Pre-wired for do-it-yourself installation.
- Complete with bar hangers, housing, lens and trim.
- Open trim, 150 watt light.
- Thermally protected.

FLUORESCENT LIGHTS FOR EVERY ROOM

Edison. 4-FOOT WHITE TRACK \$16

- Easy to install.
- Add track lighting to home.
- Designed to accept a variety of different light styles.

DELUXE HOME LAMP \$12

- Ideal lighting for small spaces around the home.
- Warm white tube included.
- Installs just about anywhere.

48-INCH.....\$16

FLUORESCENT UNDERCABINET LIGHT \$4.99

- Lights of America**
- Hang it anywhere.
 - Ideal for dark spots under cabinets.
 - 18" fluorescent bulb included.
 - Easy installation.

FLUORESCENT WRAP AROUND \$18

20 WATT, 2 LIGHT

- Great for kitchens, closets, laundry or utility rooms.
- Surface mount.

40 WATT, 2 LIGHT.....\$19

FLUORESCENT OAK END WRAP AROUND \$24

20 WATT, 2 LIGHT

- Home styled ceiling fixtures.
- Ideal for room remodeling.

40 WATT, 2 LIGHT.....\$27

COUNTRY OAK CEILING LIGHT \$27

20 WATT, 2 LIGHT

- Decorative ceiling fixtures with white acrylic diffusers and durable steel frames.

40 WATT, 2 LIGHT.....\$42

YOUR BACKYARD FUN STARTS WITH THESE VALUES!!!

GAS BBQ GRILLS

STRUCTO 40,000 BTU TRAY DELUXE \$159

- Installe™ push button electronic ignitor.
- Convenient Temp-a-Trol™ heat indicator.
- Full-length, heat-tempered Grand View™ glass window.
- Gas Monitor™ fuel gauge.
- Adjustable dual cooking controls.

42,000 BTU DRIFTWOOD \$219

- Temperature indicator.
- Full-view window.
- Space saver warming rack with basket.
- Two towel racks with utensil holders.
- Fuel sentry LP fuel level dial on control console.

STRUCTO 42,000 BTU DELUXE REDWOOD \$257

- 2-piece porcelainized cast iron-cooking grid.
- Deluxe Gas monitor™ fuel gauge.
- Full-length, heat-tempered glass window.
- Deluxe Temp-a-Trol™ heat indicator.
- Cooking timer, and many other extra features.

42,000 BTU DELUXE CART \$297

- Driftwood cart with door enclosure.
- Tempered glass shelves.
- 60-minute timer, temperature indicator.
- Tank with fuel sentry.
- 42,000 BTU Dual burner.

6' STAINED PICNIC TABLE \$34

- Constructed of Canadian whitewood with redwood stain.
- 72" table with 7-board top including matching benches.

Oakline International Inc. 4-FOOT PORCH SWING \$22

- Made of finest quality hardwood.
- Ready to paint or stain.
- Complete hardware set (chain, ceiling hooks, nuts, bolts, etc.)
- Included for easy, quick assembly.

BugFighter
 1/2 ACRE **BUG KILLER \$20**
 YOUR FINAL COST AFTER REBATE \$16
 LESS MFR. REBATE \$4
 • 15 watt high intensity black light.
 • Lures annoying, light-sensitive flying insects.
 • Up to 3/4 acre coverage.
 • LIMIT 1 REBATE PER CUSTOMER

1 ACRE \$23 AFTER \$5 MFR. REBATE*
1 1/2 ACRE \$34 AFTER \$10 MFR. REBATE*

LAVA ROCK \$2.97 NET WEIGHT 8 LBS.
 • Genuine volcanic rock for all gas grills.
 • Produces a natural char-broiled flavor.

BUILDERS SQUARE CHARCOAL BRIQUETS \$2.96 20 LB. BAG

MECO BBQ GRILLS

SIZZLER SUPREME SMOKER GRILL \$34

- 21 1/2" square grill with 362 square inches of cooking space.
- Tilt away hood with easy action inside hinges.
- Two position grid tilts to cook rare and well done at the same time.

TABLETOP ELECTRIC GRILL \$79

- Quick warm up: ready for cooking in five to 10 minutes.
- 120-volt plug for standard household outlets.
- 215 sq. inch porcelain cooking grid, cleans easily for long term wear.
- Temperature control knobs for varying heat from searing high to warm low.
- Handy grease cup for cleaner, easier removal of excess grease.

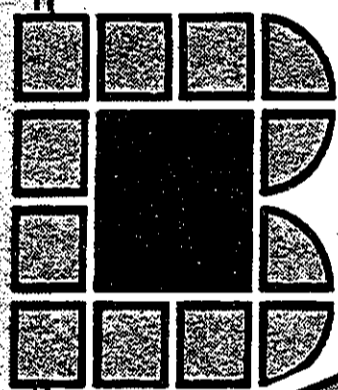

BUILDERS SQUARE
HOME IMPROVEMENT WAREHOUSE

Father's Day Special

STANLEY

INSTALL IT!
GARAGE DOOR OPENER
\$85
and it's **GUARANTEED!**

\$89

1/4 H.P. CHAINDRIVE GARAGE DOOR OPENER

- Chain drive with digital transmitter.
- Automatic on/off light on open and close.
- Installation hardware included.

STANLEY

GARAGE DOOR OPENER

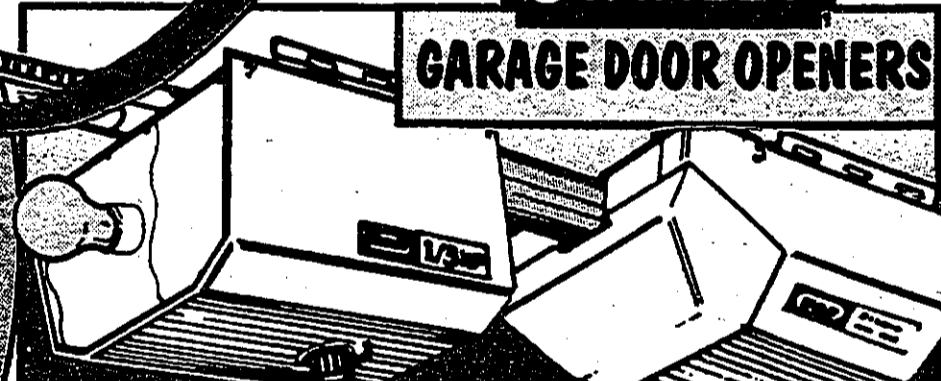

1/3 H.P. \$129 **1/3 H.P. \$154**
CHAIN DRIVE **SCREW DRIVE**

- #1800-1
- Opens door 18 ft. wide and 7 1/2 ft. high.
- 4 1/2 minute light delay.
- #4100-1
- Automatic light time-delay.
- Instant safety reverse.

WOOD PANEL GARAGE DOOR **RAISED PANEL STEEL GARAGE DOOR**

8x7 DOOR **9x7 DOOR**

\$156 **\$169** **\$222** **\$362**

16x7...\$340

STANLEY

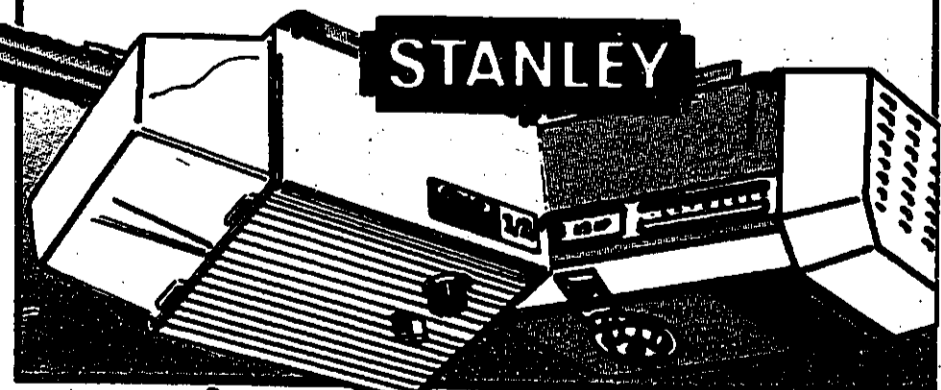

1/2 H.P. \$159 **1/2 H.P. \$179**
CHAIN DRIVE **LIGHTMAKER**

- #3200-1
- Extra power to open heavy doors.
- 4 1/2 minute light time delay.
- #6500-1
- Turns on indoor/outdoor lights from the convenience of your car.

For Your Convenience
Our Store Hours Are:
7:30 am - 9 pm
Monday thru Saturday
9 am - 6 pm
Sunday

ONLY WE GUARANTEE THE LOWEST PRICES!
©1988 BUILDERS SQUARE, INC.

We guarantee the lowest price on every item...every day! And, if you find a lower price at a competitor (Heaven forbid!) just let us know and we'll change it plus we'll give you 10% more in SQUARE BUCKS for your next purchase. Identical items only (same manufacturer and model number). Other limited to items in stock. No rain checks. Price comparisons are at time of purchase. We reserve the right to limit quantities to dealers and competitors.



NOW SEVEN DETROIT AREA LOCATIONS:

- 4810 E. WILSON (BASELINE) BETWEEN VAN DYKE AND HOOVER RD. 893-4900
- IN LIVONIA • 3100 PLYMOUTH RD AT MIDDLE BELL RD ACROSS FROM WONDERLAND MALL (SOUTH OF I-75) 422-1900
- IN NOVI • 1/2 MILE RD AT POND RD ACROSS FROM TWELVE OAKS MALL 344-8255
- IN PLYMOUTH • 1500 MILLER RD. 477-7327
- IN STERLING HEIGHTS • 1200 HALL RD W/ I-75 AT MIJ 254-4640
- IN SOUTHGATE • 1800 DIX TOLEDO RD AT EUREKA RD 236-8500
- IN MT. CLEMENS • 3755 S. GRATIOT 1 BLOCK N. OF METRO PARKWAY 466-0520

DET

THIS SEASON
FOR MORE...

COOL ITEMS-HOT BARGAINS!

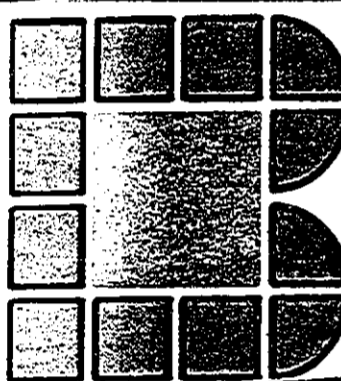

**BUILDERS
SQUARE®**
HOME IMPROVEMENT WAREHOUSE

THE LARGEST
SELECTION OF FANS TO
CHOOSE FROM

WE GUARANTEE THE LOWEST PRICES!

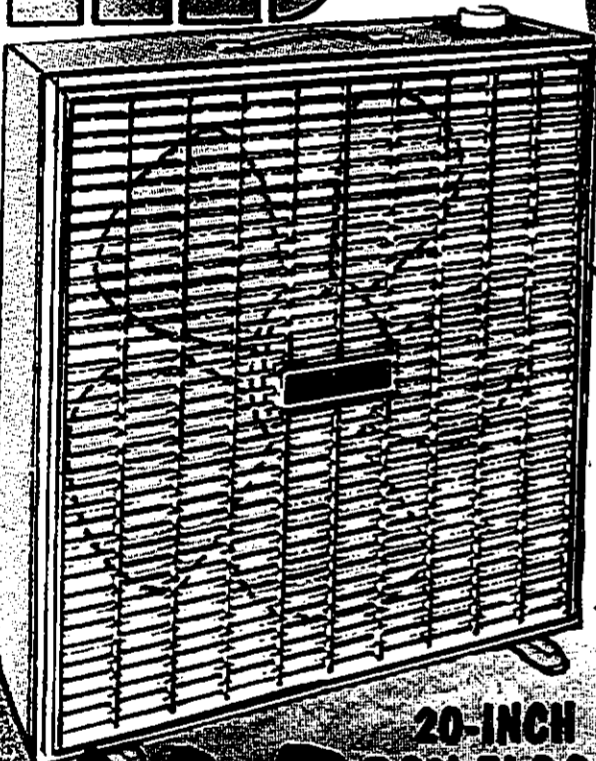

#3723

**20-INCH
BOX FLOOR
FAN**

\$34

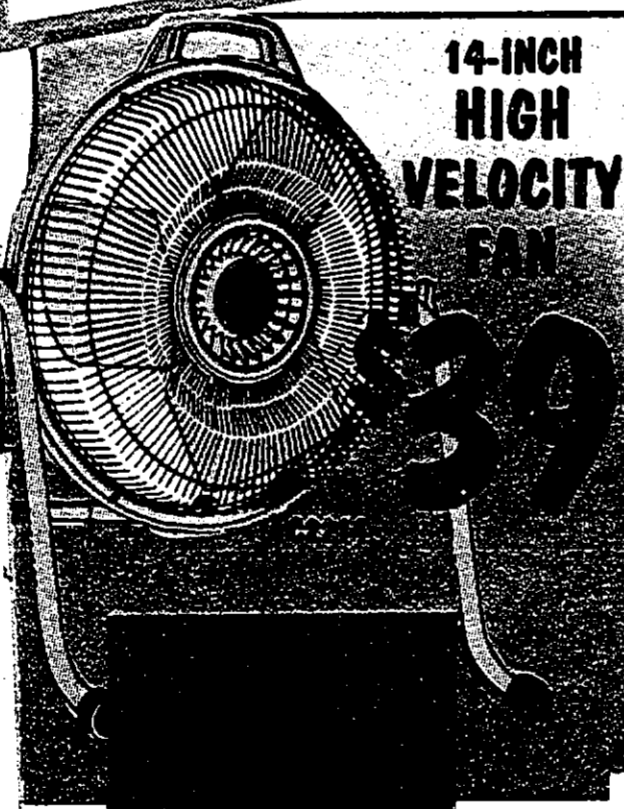

**14-INCH
HIGH
VELOCITY
FAN**

\$39

**12-INCH
OSCILLATING
DESK/TABLE
FAN**

\$15

- Three speed for efficient air delivery
- Whisper quiet energy efficient motor
- Settings for oscillating or stationary operation
- UL-listed

16-INCH \$18

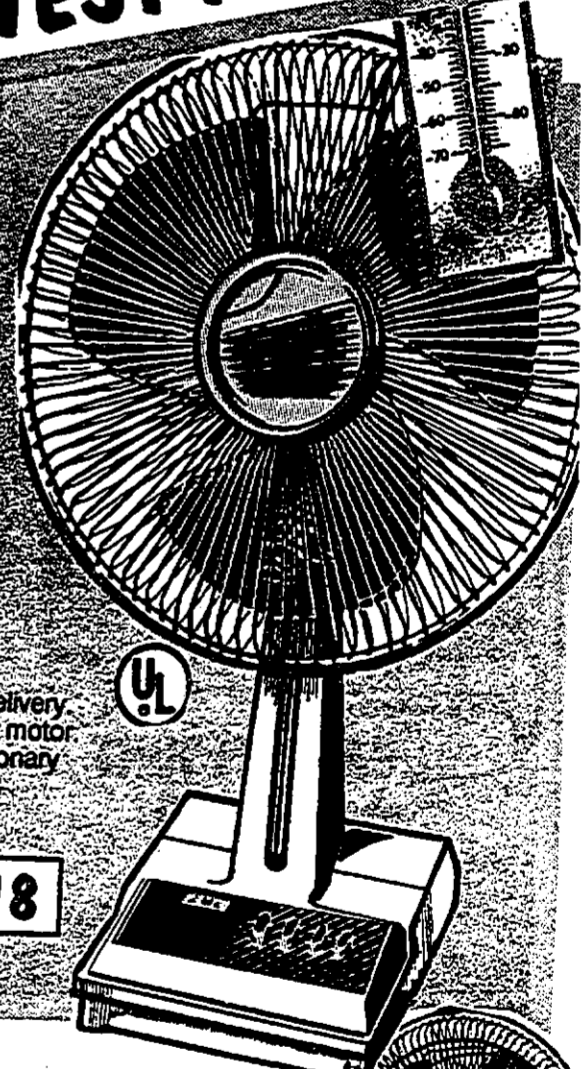

**18" ROLLING
HI-VELOCITY
CIRCULAR FAN**

\$69

OUR LOW PRICE
LESS MFG. REBATE.....**\$10**
YOUR COST AFTER REBATE.....**\$59**

LIMIT SUBJECT TO MFR'S SPECIFICATIONS
• Easily cools an average 5-room home.

**18" WHOLEHOUSE
AIR
CIRCULATOR**

\$55

OUR LOW PRICE
LESS MFG. REBATE.....**\$10**
YOUR COST AFTER REBATE.....**\$45**

LIMIT SUBJECT TO MFR'S SPECIFICATIONS
• Easily cools an average 5-room home
• Delivers 10 times more cooling power than ordinary fans



PATTON

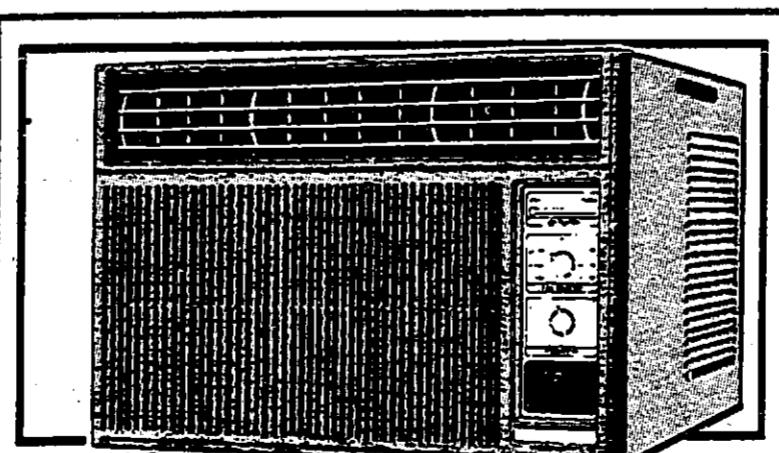

JUNIER #31075

**7,500 BTU
AIR
CONDITIONER**

\$279

- Dynamically balanced turbo fan
- Easy slide-in, slide-out filters
- Ventilation control lever
- Automatic thermostat control
- Energy efficiency rating of 8.7

**16-INCH
STAND
FAN**

\$28

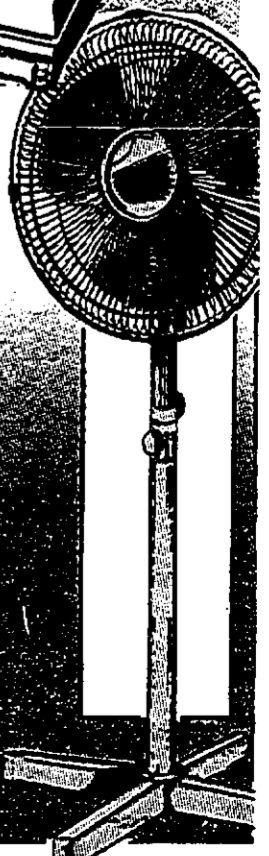

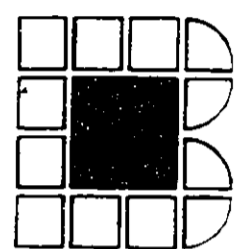

SAVING IS A BREEZE AT BUILDERS SQUARE!

12,500 BTU AIR CONDITIONER
\$379

- Slide-out chassis for easy servicing.
- Rust protected cabinet and base pan.
- Easy slide-in, slide-out filters.

5,000 BTU TOTE AWAY AIR CONDITIONER
\$197

- Adjustable automatic thermostat.
- 2-speed fan/3 cooling levels.
- Fresh-air ventilation control.
- Built-in carry handle for convenient portability.

POWER VENTS

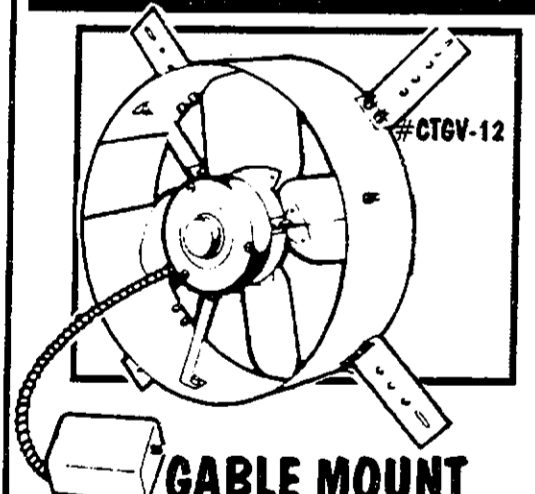

GABLE MOUNT
\$25

- 12" diameter shroud
- Heavy duty galvanized steel construction.
- Automatic thermostat.
- 620 C.F.M.

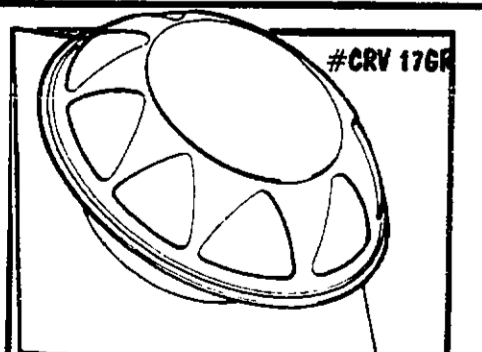

ROOF MOUNT
\$28

- Roof mount for smaller attics.
- 17" diameter dome, 17" square base
- Automatic thermostat.

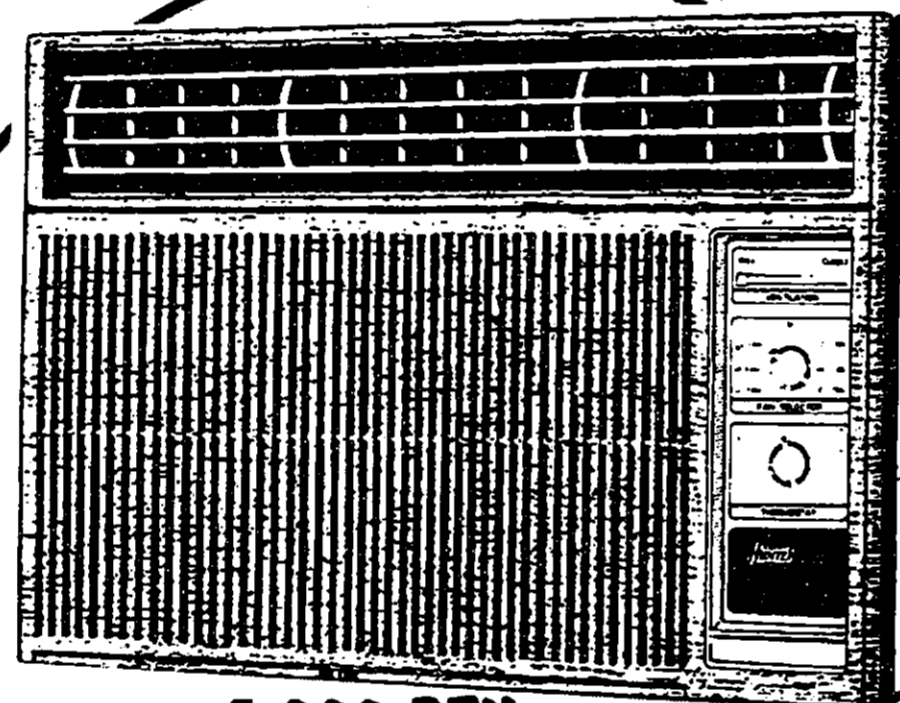
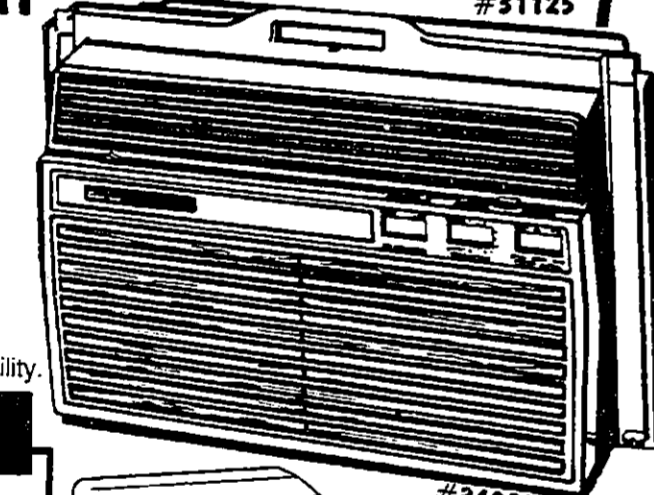
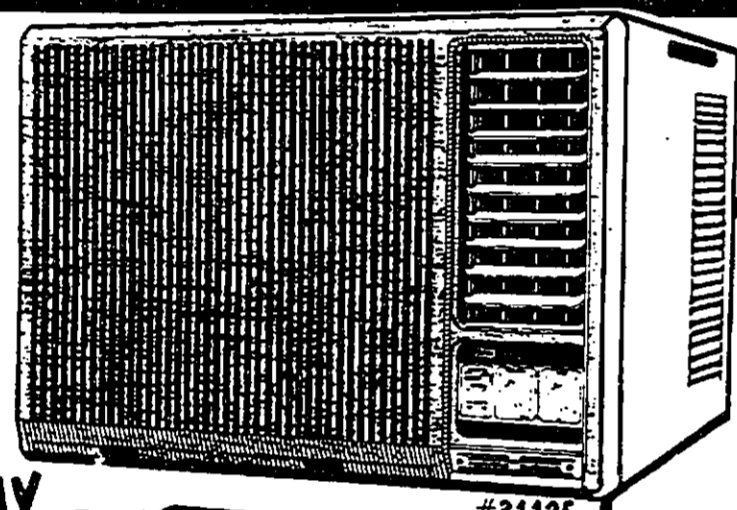

5,000 BTU AIR CONDITIONER

\$219

- Dynamically balanced turbo fan.
- Easy slide-in, slide-out filters.
- Ventilation control lever.
- Automatic thermostat control.
- Energy efficiency rating of 8.7.

PROGRAMMABLE TIMER
\$14

- Guards home against potential burglary by providing that lived in look.
- For air conditioners up to 115V-15 amp.

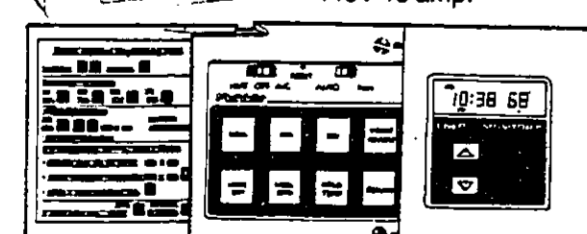

ENERGY MONITOR PROGRAMMABLE THERMOSTAT
\$39

- Exclusive energy monitor displays energy.
- Usage in hours and minutes.
- Easy to read digital read out.
- Finger tip programming.
- Stand by power system.

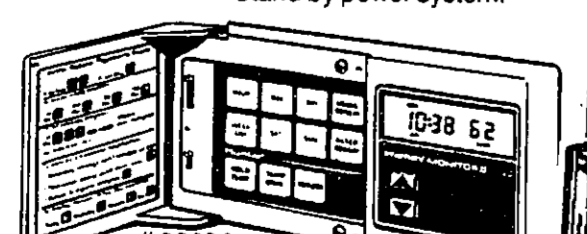

ENERGY MONITOR II PLUS PROGRAMMABLE THERMOSTAT
\$49

- Auto-season program switches between heat & cool automatically.
- Finger-tip programming.



10-INCH PORTABLE EXHAUST FAN
\$24

- Manually reversible to bring in fresh air.
- Guarded front and back for complete safety; polarized plug & thermal protector.
- Corrosion resistant finish on all parts.

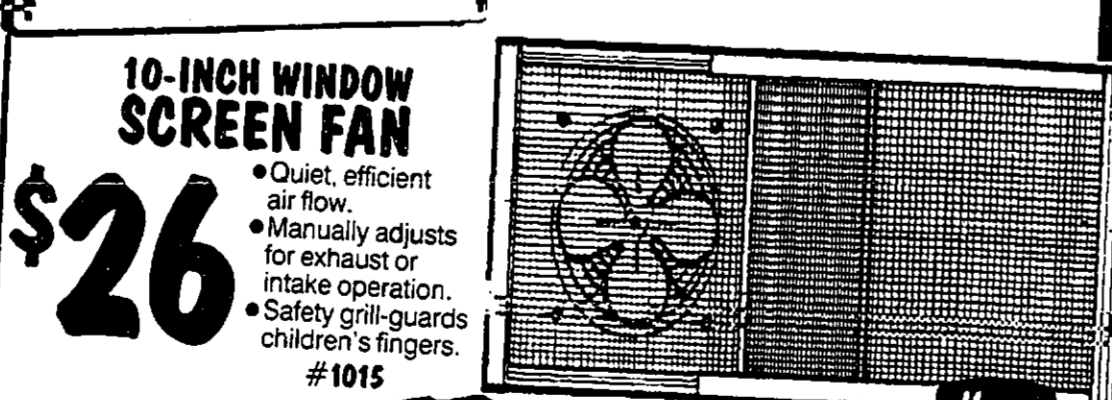

10-INCH WINDOW SCREEN FAN
\$26

- Quiet, efficient air flow.
- Manually adjusts for exhaust or intake operation.
- Safety grill guards children's fingers.



TWIN 8-INCH FAN
\$32

- Easy installation - no tools required.
- Twin 8" fans with two speeds for high velocity air delivery or whisper quiet operation.

QUALITY CEILING FANS FROM HUNTER

WE OFFER YOU MORE IN SELECTION & SAVINGS!



48-INCH SUMMER BREEZE
\$59

- Real wood blades.
- Motor housing enhanced with designer touches
- Three speed electrically reversible motor with special noise reducers.



42 INCH-WHITE ORIGINAL
\$115

- Three speed electrically reversible motor.
- Unique and innovative "break away" switch chain.

BRASS.....\$149



52-INCH ORIGINAL
\$139

- Elegant yet energy-saving ceiling fan.
- Electrically reversible motor.
- Pre-balanced and pre-assembled blades.

52-INCH ORIGINAL
\$215

- Three-speed reversible motor in heavy duty, all-metal housing.
- Balanced, matched wood blades.
- Light kit adaptable.

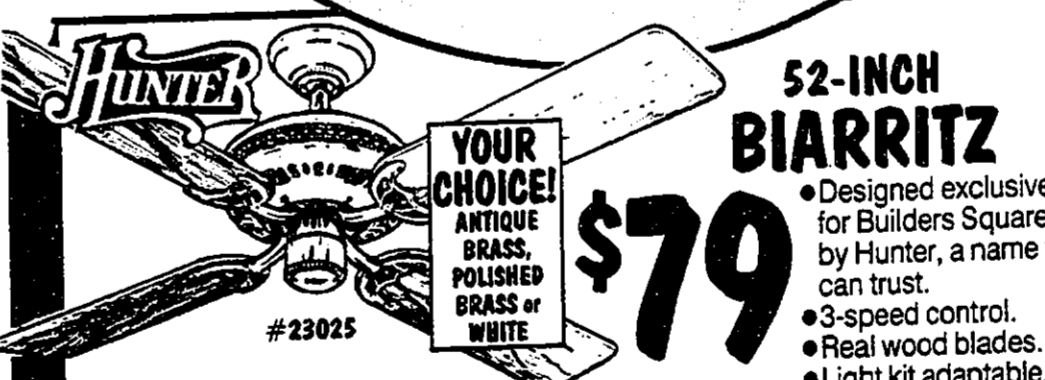

52-INCH BIARRITZ
\$79

- Designed exclusively for Builders Square by Hunter, a name you can trust.
- 3-speed control.
- Real wood blades.
- Light kit adaptable.



52-INCH LO-PROFILE BIARRITZ
\$84

- Custom designed 3-speed, electrically reversible motor.
- Real wood blades.
- Metal motor housing.
- Light kit adaptable.

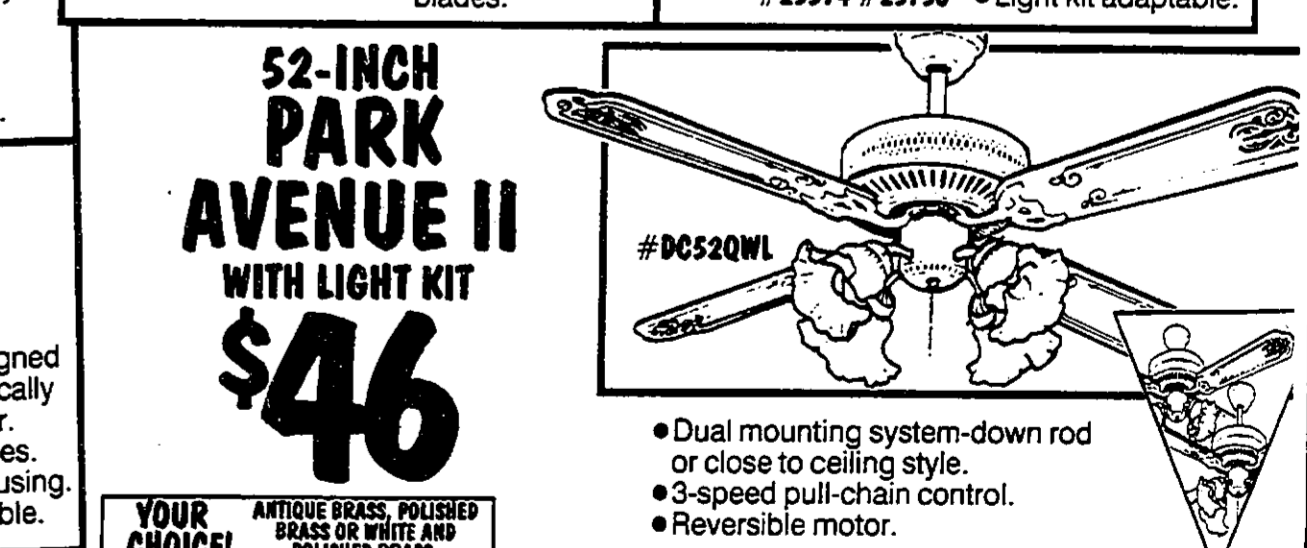

52-INCH PARK AVENUE II WITH LIGHT KIT
\$46

- Dual mounting system-down rod or close to ceiling style.
- 3-speed pull-chain control.
- Reversible motor.

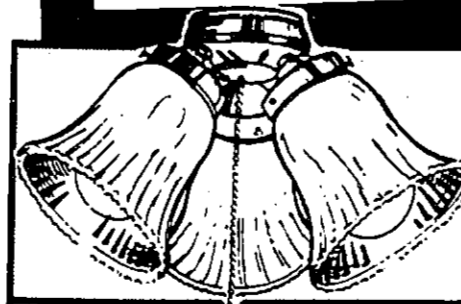

3 LITE-RIBBED AMBER LIGHT KIT
\$12

- 3 lite ribbed champagne glass.
- Antique or polished brass.

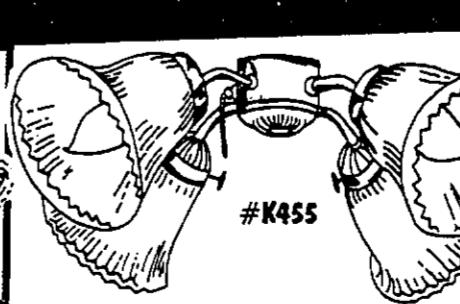

4 LAMP WHITE FROSTED LIGHT KIT
\$16

- 4 lamp frosted light kit.
- Antique brass or bright brass finish.



BEVELED GLASS SINGLE LITE KIT
\$17

- Smoked beveled glass.
- Antique brass or polished brass.

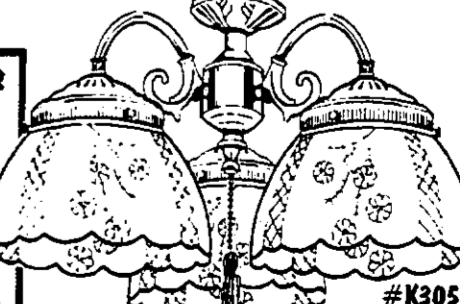

3 LAMP VICTORIAN LIGHT KIT
\$18

- Victorian decorator design with pull chain.
- Universal fit for ceiling fans.

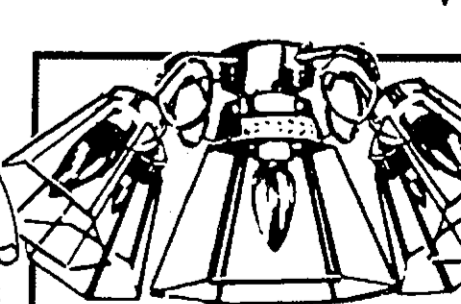

5 LIGHT BEVELED GLASS LIGHT KIT
\$29

- Beautiful smoked amber glass.
- Completely assembled and wired.

PULL - OUT THIS SECTION FOR MORE...

HOT WEATHER SPECIALS

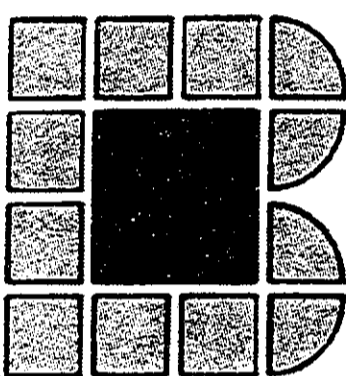

BUILDERS HAS THE LARGEST SELECTION OF SQUARE® CEILING FANS THAT'LL

HOME IMPROVEMENT WAREHOUSE

BEAT THE HEAT

WE GUARANTEE THE LOWEST PRICES!



36-INCH WHITE BLADE

\$11

- Compact motor.
- 3-speed pull chain control
- Light kit adaptable.

INSTALL IT! CEILING FANS \$40 and it's GUARANTEED!

#V36N-3M WH



36-INCH 4-BLADE

\$15

- 36" reversible blade span
- Designed with downrod mount
- Light-kit adaptable

ANTIQUE BRASS or POLISHED BRASS 42-INCH FAN... \$17

YOUR CHOICE! BRIGHT BRASS OR ANTIQUE BRASS

YOUR CHOICE! CEILING FAN SCHOOLHOUSE LIGHT KIT or ROUND GLOBE

4.88

SCHOOLHOUSE LIGHT KIT:
• Complete with all mounting hardware, instructions and pull chain.

ROUND CEILING FAN GLOBE:
• White globe available in antique or bright brass finish.

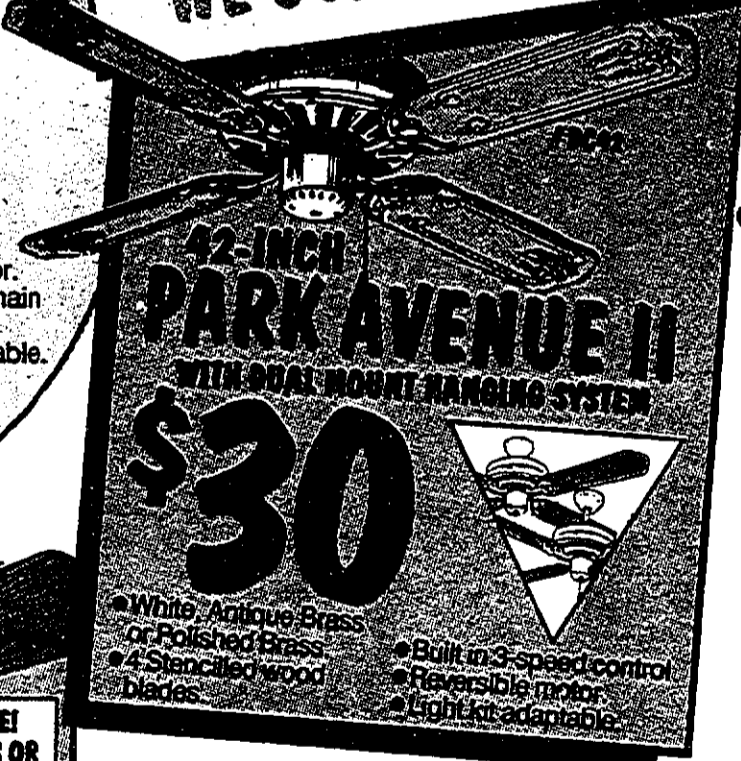

42-INCH PARK AVENUE II WITH DUAL MOUNT HANGING SYSTEM

\$30

- White, Antique Brass or Polished Brass
- 4 Stencilled wood blades
- Built in 3-speed control
- Reversible motor
- Light kit adaptable



42-INCH ROYAL FLUSH

\$30

YOUR CHOICE! WHITE & BRASS, ANTIQUE BRASS, OR POLISHED BRASS

- Mounts close to the ceiling
- 4 Stencilled wood blades
- Built in 3 speed control
- Reversible motor
- Light kit adaptable

52" ROYAL FLUSH... \$34

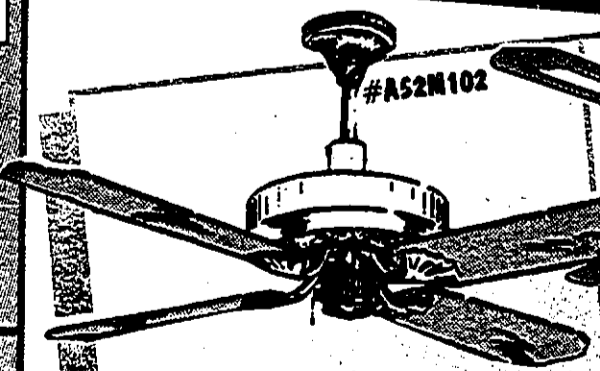

52-INCH HIGH STYLE OLD VIC

\$39

- Built in three speed control.
- Reversible motor.
- Lite-kit adaptable.
- 4 Stencilled wood blades.



SOLID OAK WITH BRASS 52-INCH OAK RICH

\$39

- 4 inserted wood blades.
- Solid wood upper and lower housings.
- Built in 3 speed control.
- Reversible motor.
- Lite kit adaptable.



52-INCH DELUXE-5 BLADE PARK AVENUE II

\$46

- 5 cane imported wood blades.
- Built in 3 speed control.
- Reversible motor.
- Light-Kit Adaptable.
- With dual mount hanging system.