

## Missing gravestones discovered near lake

By PHIL GINOTTI  
 staff writer

Southfield officials have confirmed that the two gravestones found in Novi's Shawood Lake last week were removed from their cemetery and do not point to evidence of burials near the lake.

The two headstones, dating back to 1865 and 1904, were found under a thin layer of mud Sunday, July 17, near Duana Street on Shawood Lake.

At the time of their discovery, residents said the finding supported their claim of unknown burial grounds in the area. Those residents are claiming that the area is an old Indian burial ground in an effort to stop development of "The Landing," a large hotel/marina development slated to be built near Shawood Lake.

But The Novi News has learned that the two gravestones belong in the Southfield cemetery, located at 10½ Mile in Southfield. Sources have confirmed that the headstones don't actually mark graves in the Shawood Lake area, refuting some residents' claims.

The gravestones were traced through county and local records this week by The Novi News staff.

One of the stones reads "Jacob G. Tice, born Feb. 22, 1831 — died Nov 21, 1865." The other, a shorter marble slab, reads "Grace, wife of C.S. McQuarter, born Oct. 2, 1886 — died February 28, 1904."

Both stones were found lying on their backs, according

to resident Dewey Marlow, whose five-year old son reportedly found the gravestones.

Jef Farland, Southfield's Parks and Recreation Deputy Director, said both the Tice and McQuarter stones were discovered missing from their cemetery Tuesday afternoon.

"We're missing both of them," Farland said. "They are ours, and they do belong in our cemetery."

"At this point, we have to get to work on getting them back," he added.

Novi police also found a slab near West Road on July 13. That partially readable stone appears to be that of a "Lucinda Cleaveland" who died Oct. 30, 1861. The true location of that headstone could not be determined.

Farland said his staff is currently searching the cemetery for the Cleaveland stone, although they have no written records of it.

The Tice and McQuarter stones were confirmed through cemetery records and actual inspection of the sites, Farland said.

An official in the Oakland County Clerk, Vital Records Division, has confirmed that McQuarter died in Southfield of an unknown illness. The other two slabs aren't listed in any state, county or local records. Neither the state nor county kept records until after 1867, a clerk said.

Continued on 12



Matthew Marlow, 5, found the gravestones near Shawood Lake

Novi News/THOM DOUGHERTY

## Drivers beware Manager calls for traffic light

By PHILIP JEROME  
 managing editor

Novi City Manager Edward Kriewall is boiling mad after another accident at the Ten Mile/Beck Road intersection sent two more people to the hospital Tuesday (July 26) afternoon.

"It personally makes me sick when I drive past that intersection and see people lying in the ditch," said a still-angry city manager two hours after Tuesday's accident had occurred.

The object of Kriewall's ire is the Oakland County Road Commission (OCRC), which has jurisdiction over Ten Mile and Beck Road and is responsible for installing proper signalization.

The OCRC has agreed to install a traffic light at the intersection, but installation is not scheduled to occur until October, the start of the OCRC's new fiscal year.

In the meantime, Kriewall seethes every time another accident occurs at the intersection.

"The thing that bothers me is the number of accidents which have occurred while we're waiting for the signal to be installed," said Kriewall, brandishing a handful of 13 traffic accident reports which have taken place at the intersection during the first six months of the year.

"And you can probably add three or four more accidents at that intersection since July 1," added the city manager.

Continued on 9



Novi News/THOM DOUGHERTY

A Novi firefighter works at freeing James Taylor from the cab of the garbage truck

## Election slated next Tuesday

By PHILIP JEROME  
 managing editor

There's a hotly-contested race for the Oakland County Prosecutor nomination on the Republican side of the ballot. And there's much local interest in a five-person race for Judge of the 52nd District Court on the non-partisan portion of the ballot.

But outside of those two races there's not a great deal going on in the primary election next Tuesday, Aug. 2.

Novi voters will head to the polls next Tuesday to participate in the primary election which, in several cases, will determine the names of

the candidates who will continue on to the November general election.

Polls will open at 7 a.m. and close at 8 p.m.

Under the primary format, registered voters must decide whether to vote for Republican candidates, Democratic candidates or candidates of the Tisch Independent Citizens Party.

All voters may vote on the non-partisan judicial portion of the ballot, which includes candidates for the Court of Appeals and Probate Court in addition to the 52nd District Court.

In Novi, interest centers on the

Continued on 16

## District court race heads to primary

By PHIL GINOTTI  
 staff writer

The candidates in the race for the 52nd District Court bench all agree that the court is efficient and well-run, but stop just short of laying any of that praise at the feet of incumbent Brian MacKenzie.

MacKenzie, and challengers Peter Abbo, Emery Jacques, Terence Jolly and Michael Reeds will square off in a primary Tuesday, August 2. Voters may choose one, though the top two vote-getters will advance to the November 8 general election for a final runoff.

The various campaign stances: □ Reeds has called for night court sessions, more attention to alternative sentencing for drunk drivers, and a higher degree of

community involvement for judges.

□ Jacques supports implementation of a liaison panel of judges and court administrators to help solve scheduling conflicts between district and circuit courts. He also supports the addition of a magistrate at the 52nd District Court to handle smaller cases.

□ Jolly supports victim involvement in sentencing, alternative sentencing for minor crimes, and a higher degree of community involvement for judges.

□ Abbo said he supports having judges going back to putting in a full day, starting on the bench at 8:30 a.m. promptly, among other reforms designed to solve backlog problems.

□ MacKenzie supports the addi-

Continued on 6

## Report advises communication

By BRENDA BONZHEIM  
 staff writer

A perceived lack of communication between school district administrators and the Novi Meadows School staff deserves the attention of an objective consultant, according to results of a long-awaited report about the school.

Novi Board of Education was presented with a final draft of the Novi Meadows Evaluation Committee Report at its July 21 meeting, ending months of study and anticipation.

The majority of field work and interviews forming the basis of the report was conducted by Philip Kearney, Interim Dean of the School of Education at the University of Michigan; and Karen Urbchat, a general education consultant at Wayne County Intermediate

**Report: 'We are of the firm view that this effort demands, at least initially, an outside consultant — an external agent who can act as the catalyst necessary to bring all parties together in a truly cooperative and collaborative effort.'**

School District.

Other committee members providing input in the report included Eric Center, a science teacher at Novi Meadows, and Julie Abrams, a Novi resident.

The final recommendation in the

report states the following:

"The district should initiate a long-term process involving the administration and staff of Novi Meadows — and parents as appropriate — working as a group

with an outside consultant well-

versed in group dynamics and the art of building cooperative and collaborative relationships.

"The goals of this effort should be embedded in the effective school's philosophy and should address in particular the building of a positive school climate; the establishment of effective communications among administration, staff, students, and parents; and the further development and strengthening of a balanced curriculum.

"We are of the firm view that this effort demands, at least initially, an outside consultant — an external agent who can act as the catalyst necessary to bring all parties together in a truly cooperative and collaborative effort."

A group of Novi Meadows parents attended last week's meeting and

Continued on 12

**103**  
**GARAGE SALES**  
 in the Green Sheet

Gree Garage Sale Kits  
 See Classification 103

Green Sheet  
**(313) 348-3022**

inside	
ANN WILLIS	14A
AREA BRIEFS	6A
BUSINESS	1B
DIVERSIONS	5C
EDITORIALS	14A
IN SHAPE	4D
LETTERS	15A
LIVING	1C
NOVI BRIEFS	4A
NOVI HIGHLIGHT	2C
PEOPLE	4C
PHIL JEROME	14A
POLICE BLOTTER	4A
EDITORIAL	349-1700
ADVERTISING	349-1700
CLASSIFIEDS	348-3024
DELIVERY	349-3627

















# Novi voters head to polls for upcoming election

Continued from Page 1

52nd District Court judgeship where five individuals, three of them with local ties, are vying for two positions. The top two vote-getters in the primary will advance to the ballot in the November general election. The five primary candidates for the judgeship are Peter Abbo of Union Lake, Emery Jacques Jr. of Novi, Terrence Jolly of Novi, Brian Mackenzie of Novi and Michael Reeds of Walled Lake. Mackenzie currently serves on the 52nd District Court bench, having been appointed by Gov. James Blanchard earlier this year to fill the

vacancy created by the resignation of Martin Boyle. Outside of that race, however, most of the action is on the Republican side of the ballot, particularly in the four-person race for the Republican nomination for Oakland County Prosecutor. Seeking that nomination are State Senator Richard Fessler, former West Bloomfield Township Trustee Jeffrey Leib, Oakland County Commissioner Jack McDonald and Oakland County Assistant Prosecutor Dick Thompson. All four are vying to be the Republican candidate for the prosecutor's office currently held by L. Brooks Patterson, who is

not a candidate for re-election this year. The winner of the Republican primary will advance to the November general election where he will be opposed by Barry Kraemer, who is unopposed for the Democratic nomination in the primary. Two other races appear on the Republican side of the primary ballot. Jim Dunn and Robert Huber are vying for the party's nomination for U.S. Senator with the winner meeting Democratic Incumbent Donald Riegle in November. The other race is for Oakland County Drain Commissioner where William Eckstein and George Kuhn

are seeking the Republican nomination. The winner will square off in November against Democratic Gene Kuthy who is unopposed for his party's nomination. On the Democratic side of the primary ballot, there's even less action. The only race is for County Clerk/Register of Deeds where Philip Marcuse and Diana Trivax are running for the right to take on Lynn Allen in November. There are three races on the non-partisan judicial ballot. In addition to selecting two of five candidates for 52nd District Court, voters will select two of 13 candidates for Judge of the Court of Appeals and one of five can-

didates for Judge of the Probate Court. The following is a list of Novi polling places:  
Precinct 1: Church of the Holy Cross, 46200 Ten Mile  
Precinct 2: Middle School South, 25299 Taft Road  
Precinct 3: Novi Public Library, 45345 W. Ten Mile  
Precinct 4: Lakeshore Park Community Building, 601 South Lake Drive  
Precinct 5: Orchard Hills School, 41900 Quincy Drive  
Precinct 6: Fire Station No. 1, 42875 Grand River  
Precinct 7: Village Oaks School, 25333 Willowbrook Road  
Precinct 8: Chateau Estates Clubhouse, 42000 Carousal Drive  
Precinct 9: Novi High School Auditorium, 24062 Taft Road  
Precinct 10: Fire Station No. 3, 42785 Nine Mile

Novi Clerk Geraldine Stipp said the city has given out approximately 520 absentee ballots thus far. Those ballots will be available by mail up until 2 p.m. Saturday. Absentee ballots will be available in person Monday until 4 p.m. Residents taking out ballots Monday must vote in the building and may not leave city hall with the ballot.



## Discover WALLED LAKE

- A- Walled Lake A & W
- B- Senior House
- C- Jays Dairy Queen
- D- Modern Floors
- E- Happy Hooker Knit Shop
- F- Looney Bin Comedy Club

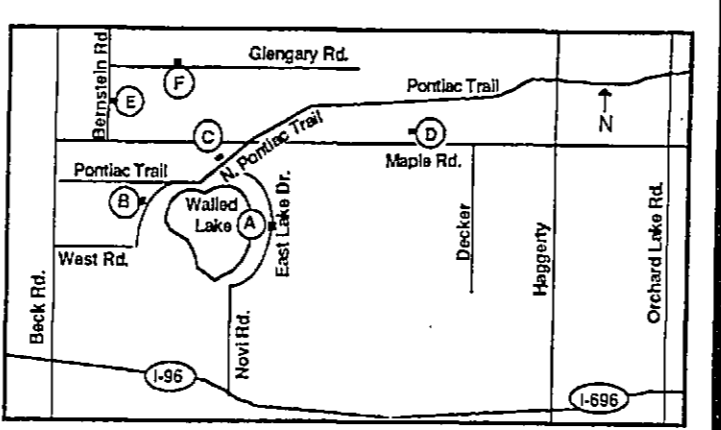

### MAKE A WISH COME TRUE

5 Sizes to Choose From

WITH A DAIRY QUEEN FROZEN CAKE

Call Ahead For Availability 624-4201

Make this birthday a special birthday with a luscious taste you'll remember. A Dairy Queen® Frozen Happy Birthday Cake is rich with good things like thick dark fudge and crisp chocolate crunch with creamy chocolate and vanilla Dairy Queen® soft serve layers. Bring home a Dairy Queen® frozen cake for the next birthday in your life.

### JAYS DAIRY QUEEN

551 N. Pontiac Trail • Walled Lake

### Drive in for a thirst-quenching mug of the original real draft rootbeer!

Available in take-home quart, half or full gallon containers!

**FREE BABY ROOT BEER**  
For Children Under 5 Years Of Age

### A&W

725 E. Walled Lake Drive  
Walled Lake  
For Take Out Orders Call 624-2441

**DUPONT CERTIFIED STAINMASTER CARPET**  
Starting At \$9.99 Sq. Yd.

**NO WAX VINYL FLOORS:**  
• Mannington  
• Tarkett  
• Armstrong  
• Congoleum

**HARTCO WOOD FLOORING**  
• Select Parquet or Plank  
• WINDOW BLINDS  
• WALLPAPER

**MODERN FLOORS**  
1877 Maple - Walled Lake (West of Decker)  
624-0333  
Mon. Thurs. 9-8; Tues. Wed. Fri. 9-6; Sat. 10-4

Register now for Knitting & Crocheting Classes

• Designer Yarns • Pattern Books

### 25% OFF any ANNY BLATT YARN

Summer Hours:  
Mon 12 to 9 Wed Closed Sat 10 to 6  
Tues 10 to 6 Thurs/Fri 10 to 7 Sun 10 to 4

Happy Hooker Knit Shop  
2614 Beavertail Rd. (S. Of Glengary)  
Walled Lake • 624-8040

### Enjoy Elegant Senior Living At:

## Senior HOUSE

Retirement Residence  
669-5330

Retirement Residences  
"This is your house..."  
45182 West Rd. (Just South of Pontiac Trail)

### The LOONEY BIN

Friday & Saturdays

Featuring July 29th & 30th In Live Comedy Entertainment

### S.R.O.

A Hilarious Comedy Team

Always Offering the Finest Live Comedy Entertainment

### 3 NEW COMEDIANS EVERY WEEKEND

Featuring the Finest Live Comedy Entertainment At:

### THE WOLVERINE LOUNGE

1655 Glengary • Walled Lake  
Call For Reservations and Information 669-9374  
Fine Food • Cocktails

In a beautiful secure country setting at Pontiac Trail and West Road, elegant apartments designed for seniors are now available. Our comfortable, relaxed atmosphere is enhanced by landscaped walking trails, pond with ducks, gazebo, courtyards, library, coffee shop, TV lounge, movie theatre, beauty shop and exercise room. Other available services includes meals, housekeeping, laundry, recreational and social activities and transportation.

A 24-hour emergency call-in is part of the master plan at Senior House, which leases apartments on a monthly basis starting at \$995. There is no leases to sign.

LOBBY AREA

RESIDENCE ROOM

# GREEN SHEET

Sliger/Livingston East

Section B

Wednesday/Thursday — July 27/28, 1988



Les Neal (left) is helping to finance his college education by operating a house-painting company

## Painting is lucrative for college student

... Quality Home Painting Company is far from an amateur operation. No loud music accompanies the painters who arrive with a fully-equipped van and work steadily as Neal lays out the job.

By JEAN DAY

Some day in the future Les Neal hopes that another painter, maybe one of his present crew, will inherit his business — just as he did a few years ago.

As a young teenager, the Northville resident began painting for Mark Stec. When Stec moved to Florida, Neal took over his business.

A 1981 graduate of Northville High School, Neal has continued his studies at Eastern Michigan University, majoring in bio-chemistry, and also has continued his firm.

When you consider that Neal and his crew paint about 94 homes a summer, you realize this is no part-time operation.

Neal and the crew work a 65-70 hour week during the summer, usually beginning work at 7:30 a.m. In the winter, Neal cuts down to a 20-hour week to continue his studies.

Neal is proud of the fact that he has been a member of the Northville Community Chamber of Commerce for three years.

"It was the biggest boost for my business when I joined the chamber," he says.

### GRAND RIVER EQUINE FEEDS

51680 Grand River • Wilcom • (313) 348-8310  
Hours: Mon.-Fri. 8:00am-5:00pm; Sat 8:00am-2:00pm

Horse Feed • Hay • Straw  
Custom Mixed Horsefeed  
Quantity Price Breaks Available

While You Wait!

Telmin B Wormers \$8.00 each for 10 or more

Dog & Cat Food • Horse Supplies  
Wild Bird Seed • Wood Shavings  
Poultry Feed • Straw

### GWILLIKER'S BATTERY & SPIRITS

437-7693

Senior Citizens Day August 1st  
Complete Turkey Dinner \$5.95

Turkey, dressing, mashed potatoes & gravy, cranberry sauce, salad, roll & butter, coffee, tea or soft drink

57036 Grand River • New Hudson

### SUNSHINE FARM & GARDEN "THE HERB FARM"

HERB PLANTS & DRIED FLOWERS

A Shop Stocked With Herbs Flowers, Baskets, Books, Wreaths and Many Other Treasures.

Display Gardens To Delight You!

### Sunshine Farm & Garden

2450 N. Wilcom Rd.  
15 Miles North of I-96  
Wed thru Sun 10 to 5 (313) 685-2204

## D.E. McNABB'S CARPET TILE

COMMERCIAL MILLIKEN AND INTERFACE CARPET TILES

REG. \$35 Sq. Yd. to \$49 Sq. Yd.

# SALE

NOW ONLY \$7.95 Sq. Yd. to \$16.95 Sq. Yd.

DO IT YOURSELF! SUITABLE FOR COMMERCIAL USE!

EASY TO INSTALL! SUITABLE FOR RESIDENTIAL USE!

VERSATILE! 18"x18" TILES!

ECONOMICAL! (NO WASTE) 100's of YARDS IN STOCK!

USED AUTO SHOW CARPET  
Reg. \$100 Sq. Yd. to \$495 Sq. Yd. REDUCED TO \$100 Sq. Yd.!

2 LOCATIONS TO SERVE YOU!

### DONALD E. McNABB CO.

McNABB MILLIKEN PLACE

31250 S. Milford Rd. Milford, Mich. 48042-8614  
PHONE: 437-8146 or 357-2626

1857 W. Grand River Ave. Okemos, Mich. 48864  
PHONE: (517) 349-8050  
HOURS: MON.-SAT. 11-7; CLOSED SUN.

5 Minutes W. of 12 Oaks Mall Off I-96; Exit 155

### SEVERSON'S MILL & FARM SUPPLY

56675 Shepoo Road • New Hudson, Michigan 48165  
Mon-Sat 9-6 (313) 437-1722

Langs Dealer • Complete Pet Supplies Stock Hauling

Complete Line of Carnation Feeds • In the Historic New Hudson Elevator

Hay Price's Got You Beat! Try Nutrena's 12% Complete Horse Pellet. No need to feed hay.

### Fletcher & Rickard

LANDSCAPE SUPPLIES INC.

Buy One Bag Of Large Float Stone

Get The Second Bag FREE

With This Coupon • Expires 8-3-88

348-1230

### Dan's Auto Repair

43151 Grand River  
348-1230

### RADIATORS

New, Guaranteed Starting At \$109.95 Installed

### South Lyon Collision Inc.

Equipped to rebuild your car back to manufacture specifications

437-6100 or 437-3222

• Frame & Unibody Straighten  
• 2 & 4 Wheel Alignment  
• Repairs completed with OEM parts & OEM paint

150 E. McHattie South Lyon

### GWILLIKER'S BATTERY & SPIRITS

437-7693

Monday, August 8th Is 8-8-88

Beer & Wine 88¢ French Fries 88¢  
Cup of Soup of the Day 88¢ Onion Rings 88¢  
1/2 Lb. Ground Round \$1.88 Appetizer Sampler \$8.88  
Fried Shrimp Dinner \$8.88 Bottle of Champagne \$8.88

57036 Grand River • New Hudson



021 Houses
FARMINGTON, \$53,000. By FARMINGTON HILLS...
HARTLAND, 3 bedroom...
HARTLAND, Beautifully maintained...
HARTLAND SCHOOLS: Sharp 3 bedroom aluminum...

Better Homes and Gardens Real Estate
Schweitzer Real Estate
505 N. Center Northville 349-1515
218 S. Main Northville 453-6800

GENTRY REAL ESTATE
MILFORD (313) 684-6666
Highland (313) 887-7500
Hartland (313) 632-8700

PREVIEW PROPERTIES
(313) 227-2200
HAMBURG, 3 bedroom starter home...
BRIGHTON, 2 bedroom...
HARTLAND, 3 bedroom...

PREVIEW PROPERTIES
(313) 227-2200
HAMBURG, 3 bedroom starter home...
BRIGHTON, 2 bedroom...
HARTLAND, 3 bedroom...

PREVIEW PROPERTIES
(313) 227-2200
HAMBURG, 3 bedroom starter home...
BRIGHTON, 2 bedroom...
HARTLAND, 3 bedroom...

PREVIEW PROPERTIES
(313) 227-2200
HAMBURG, 3 bedroom starter home...
BRIGHTON, 2 bedroom...
HARTLAND, 3 bedroom...

PREVIEW PROPERTIES
(313) 227-2200
HAMBURG, 3 bedroom starter home...
BRIGHTON, 2 bedroom...
HARTLAND, 3 bedroom...

PREVIEW PROPERTIES
(313) 227-2200
HAMBURG, 3 bedroom starter home...
BRIGHTON, 2 bedroom...
HARTLAND, 3 bedroom...

BRIGHTON WINANS LAKE By Owner
Custom A-Frame set on 3 acres - Backs up to State Land. Wooded, one of a kind setting. 3200 sq. ft., 3 bedrooms, 2 baths, designer kitchen, custom stone fireplace, heat pump, security system, sprinklers, dumb waiter, Jennair, satellite dish, etc.

Century 21 SUBURBAN REALTORS
Northville • Canton • 3 Northville building sites. Needs well and septic. Beautiful wooded lots. Priced from \$60,000. Also 2 Canton sites. Approx. 1 acre each on paved road. Each \$19,900.

Century 21 SUBURBAN REALTORS
Northville • Canton • 3 Northville building sites. Needs well and septic. Beautiful wooded lots. Priced from \$60,000. Also 2 Canton sites. Approx. 1 acre each on paved road. Each \$19,900.

Horse Farms Only A Real Estate Company
NOVI AREA
PARSHALLVILLE AREA
HARTLAND AREA

PREVIEW PROPERTIES
(313) 227-2200
HAMBURG, 3 bedroom starter home...
BRIGHTON, 2 bedroom...
HARTLAND, 3 bedroom...

PREVIEW PROPERTIES
(313) 227-2200
HAMBURG, 3 bedroom starter home...
BRIGHTON, 2 bedroom...
HARTLAND, 3 bedroom...

PREVIEW PROPERTIES
(313) 227-2200
HAMBURG, 3 bedroom starter home...
BRIGHTON, 2 bedroom...
HARTLAND, 3 bedroom...

PREVIEW PROPERTIES
(313) 227-2200
HAMBURG, 3 bedroom starter home...
BRIGHTON, 2 bedroom...
HARTLAND, 3 bedroom...

PREVIEW PROPERTIES
(313) 227-2200
HAMBURG, 3 bedroom starter home...
BRIGHTON, 2 bedroom...
HARTLAND, 3 bedroom...

Century 21 EAST, INC. at 12 OAKS 349-6800
1144 sq. ft. ranch on 1/2 acre of one in new subdivision...
1120 sq. ft. ranch on 1/2 acre with 2 car garage...
1160 sq. ft. ranch with first floor family and 2 car garage...
1800 sq. ft. ranch with full wooded basement on 2 acre wooded lot in Pine Valley Estates...

Earl Keim Realty
Carol Mason Inc.
Earl Keim Realty
Carol Mason Inc.

Earl Keim Realty
Carol Mason Inc.
Earl Keim Realty
Carol Mason Inc.

Earl Keim Realty
Carol Mason Inc.
Earl Keim Realty
Carol Mason Inc.

Earl Keim Realty
Carol Mason Inc.
Earl Keim Realty
Carol Mason Inc.

Earl Keim Realty
Carol Mason Inc.
Earl Keim Realty
Carol Mason Inc.

Earl Keim Realty
Carol Mason Inc.
Earl Keim Realty
Carol Mason Inc.

Earl Keim Realty
Carol Mason Inc.
Earl Keim Realty
Carol Mason Inc.

Earl Keim Realty
Carol Mason Inc.
Earl Keim Realty
Carol Mason Inc.

Earl Keim Realty
Carol Mason Inc.
Earl Keim Realty
Carol Mason Inc.

Earl Keim Realty
Carol Mason Inc.
Earl Keim Realty
Carol Mason Inc.

Earl Keim Realty
Carol Mason Inc.
Earl Keim Realty
Carol Mason Inc.

Earl Keim Realty
Carol Mason Inc.
Earl Keim Realty
Carol Mason Inc.

Earl Keim Realty
Carol Mason Inc.
Earl Keim Realty
Carol Mason Inc.

Earl Keim Realty
Carol Mason Inc.
Earl Keim Realty
Carol Mason Inc.

Earl Keim Realty
Carol Mason Inc.
Earl Keim Realty
Carol Mason Inc.

Earl Keim Realty
Carol Mason Inc.
Earl Keim Realty
Carol Mason Inc.

Earl Keim Realty
Carol Mason Inc.
Earl Keim Realty
Carol Mason Inc.

Earl Keim Realty
Carol Mason Inc.
Earl Keim Realty
Carol Mason Inc.

Earl Keim Realty
Carol Mason Inc.
Earl Keim Realty
Carol Mason Inc.

Earl Keim Realty
Carol Mason Inc.
Earl Keim Realty
Carol Mason Inc.

Earl Keim Realty
Carol Mason Inc.
Earl Keim Realty
Carol Mason Inc.

Earl Keim Realty
Carol Mason Inc.
Earl Keim Realty
Carol Mason Inc.

Earl Keim Realty
Carol Mason Inc.
Earl Keim Realty
Carol Mason Inc.

Earl Keim Realty
Carol Mason Inc.
Earl Keim Realty
Carol Mason Inc.

Earl Keim Realty
Carol Mason Inc.
Earl Keim Realty
Carol Mason Inc.

Earl Keim Realty
Carol Mason Inc.
Earl Keim Realty
Carol Mason Inc.

133 Industrial Commercial For Sale

PINKNEY AREA

064 Apartments For Rent

064 Apartments For Rent

074 Living Quarters To Share

101 Antiques

102 Auctions

102 Auctions

103 Garage & Rummage Sales

103 Garage & Rummage Sales

103 Garage & Rummage Sales

103 Garage & Rummage Sales

104 Household Goods

107 Miscellaneous

109 Lawn & Garden Care and Equipment

114 Building Materials

HOWELL, 25 acres... PINKNEY AREA... 064 Apartments For Rent

064 Apartments For Rent... 064 Apartments For Rent... 074 Living Quarters To Share

101 Antiques... 102 Auctions... 102 Auctions

103 Garage & Rummage Sales... 103 Garage & Rummage Sales... 103 Garage & Rummage Sales

103 Garage & Rummage Sales... 104 Household Goods... 107 Miscellaneous

109 Lawn & Garden Care and Equipment... 114 Building Materials

WHAT IS THE BARGAIN BARREL... 064 Apartments For Rent... 074 Living Quarters To Share

064 Apartments For Rent... 064 Apartments For Rent... 074 Living Quarters To Share

101 Antiques... 102 Auctions... 102 Auctions

103 Garage & Rummage Sales... 103 Garage & Rummage Sales... 103 Garage & Rummage Sales

103 Garage & Rummage Sales... 104 Household Goods... 107 Miscellaneous

109 Lawn & Garden Care and Equipment... 114 Building Materials

064 Apartments For Rent... 064 Apartments For Rent... 074 Living Quarters To Share

064 Apartments For Rent... 064 Apartments For Rent... 074 Living Quarters To Share

101 Antiques... 102 Auctions... 102 Auctions

103 Garage & Rummage Sales... 103 Garage & Rummage Sales... 103 Garage & Rummage Sales

103 Garage & Rummage Sales... 104 Household Goods... 107 Miscellaneous

109 Lawn & Garden Care and Equipment... 114 Building Materials

064 Apartments For Rent... 064 Apartments For Rent... 074 Living Quarters To Share

064 Apartments For Rent... 064 Apartments For Rent... 074 Living Quarters To Share

101 Antiques... 102 Auctions... 102 Auctions

103 Garage & Rummage Sales... 103 Garage & Rummage Sales... 103 Garage & Rummage Sales

103 Garage & Rummage Sales... 104 Household Goods... 107 Miscellaneous

109 Lawn & Garden Care and Equipment... 114 Building Materials

064 Apartments For Rent... 064 Apartments For Rent... 074 Living Quarters To Share

064 Apartments For Rent... 064 Apartments For Rent... 074 Living Quarters To Share

101 Antiques... 102 Auctions... 102 Auctions

103 Garage & Rummage Sales... 103 Garage & Rummage Sales... 103 Garage & Rummage Sales

103 Garage & Rummage Sales... 104 Household Goods... 107 Miscellaneous

109 Lawn & Garden Care and Equipment... 114 Building Materials

064 Apartments For Rent... 064 Apartments For Rent... 074 Living Quarters To Share

064 Apartments For Rent... 064 Apartments For Rent... 074 Living Quarters To Share

101 Antiques... 102 Auctions... 102 Auctions

103 Garage & Rummage Sales... 103 Garage & Rummage Sales... 103 Garage & Rummage Sales

103 Garage & Rummage Sales... 104 Household Goods... 107 Miscellaneous

109 Lawn & Garden Care and Equipment... 114 Building Materials

064 Apartments For Rent... 064 Apartments For Rent... 074 Living Quarters To Share

064 Apartments For Rent... 064 Apartments For Rent... 074 Living Quarters To Share

101 Antiques... 102 Auctions... 102 Auctions

103 Garage & Rummage Sales... 103 Garage & Rummage Sales... 103 Garage & Rummage Sales

103 Garage & Rummage Sales... 104 Household Goods... 107 Miscellaneous

109 Lawn & Garden Care and Equipment... 114 Building Materials

064 Apartments For Rent... 064 Apartments For Rent... 074 Living Quarters To Share

064 Apartments For Rent... 064 Apartments For Rent... 074 Living Quarters To Share

101 Antiques... 102 Auctions... 102 Auctions

103 Garage & Rummage Sales... 103 Garage & Rummage Sales... 103 Garage & Rummage Sales

103 Garage & Rummage Sales... 104 Household Goods... 107 Miscellaneous

109 Lawn & Garden Care and Equipment... 114 Building Materials

064 Apartments For Rent... 064 Apartments For Rent... 074 Living Quarters To Share

064 Apartments For Rent... 064 Apartments For Rent... 074 Living Quarters To Share

101 Antiques... 102 Auctions... 102 Auctions

103 Garage & Rummage Sales... 103 Garage & Rummage Sales... 103 Garage & Rummage Sales

103 Garage & Rummage Sales... 104 Household Goods... 107 Miscellaneous

109 Lawn & Garden Care and Equipment... 114 Building Materials

064 Apartments For Rent... 064 Apartments For Rent... 074 Living Quarters To Share

064 Apartments For Rent... 064 Apartments For Rent... 074 Living Quarters To Share

101 Antiques... 102 Auctions... 102 Auctions

103 Garage & Rummage Sales... 103 Garage & Rummage Sales... 103 Garage & Rummage Sales

103 Garage & Rummage Sales... 104 Household Goods... 107 Miscellaneous

109 Lawn & Garden Care and Equipment... 114 Building Materials

064 Apartments For Rent... 064 Apartments For Rent... 074 Living Quarters To Share

064 Apartments For Rent... 064 Apartments For Rent... 074 Living Quarters To Share

101 Antiques... 102 Auctions... 102 Auctions

103 Garage & Rummage Sales... 103 Garage & Rummage Sales... 103 Garage & Rummage Sales

103 Garage & Rummage Sales... 104 Household Goods... 107 Miscellaneous

109 Lawn & Garden Care and Equipment... 114 Building Materials

064 Apartments For Rent... 064 Apartments For Rent... 074 Living Quarters To Share

064 Apartments For Rent... 064 Apartments For Rent... 074 Living Quarters To Share

101 Antiques... 102 Auctions... 102 Auctions

103 Garage & Rummage Sales... 103 Garage & Rummage Sales... 103 Garage & Rummage Sales

103 Garage & Rummage Sales... 104 Household Goods... 107 Miscellaneous

109 Lawn & Garden Care and Equipment... 114 Building Materials

064 Apartments For Rent... 064 Apartments For Rent... 074 Living Quarters To Share

064 Apartments For Rent... 064 Apartments For Rent... 074 Living Quarters To Share

101 Antiques... 102 Auctions... 102 Auctions

103 Garage & Rummage Sales... 103 Garage & Rummage Sales... 103 Garage & Rummage Sales

103 Garage & Rummage Sales... 104 Household Goods... 107 Miscellaneous

109 Lawn & Garden Care and Equipment... 114 Building Materials

064 Apartments For Rent... 064 Apartments For Rent... 074 Living Quarters To Share

064 Apartments For Rent... 064 Apartments For Rent... 074 Living Quarters To Share

101 Antiques... 102 Auctions... 102 Auctions

103 Garage & Rummage Sales... 103 Garage & Rummage Sales... 103 Garage & Rummage Sales

103 Garage & Rummage Sales... 104 Household Goods... 107 Miscellaneous

109 Lawn & Garden Care and Equipment... 114 Building Materials

SMART SHOPPERS USE THE GREEN SHEET... LOOKING for old frames, crochets, quilts, oak and wicker furniture...

DO NOT WAIT UNTIL MONDAY!... YOU can place your ad any day of the week...

Blueberries U-PICK... 1144 Peavy Rd. (off Mason Rd. West of Howell)...

Blueberries U-PICK... 1144 Peavy Rd. (off Mason Rd. West of Howell)...

Hodges Farm Equip. "Buy of the Month" MODEL 180 D "LOADED WITH FEATURES"...

064 Apartments For Rent... 064 Apartments For Rent... 074 Living Quarters To Share

064 Apartments For Rent... 064 Apartments For Rent... 074 Living Quarters To Share

064 Apartments For Rent... 064 Apartments For Rent... 074 Living Quarters To Share

064 Apartments For Rent... 064 Apartments For Rent... 074 Living Quarters To Share

064 Apartments For Rent... 064 Apartments For Rent... 074 Living Quarters To Share

ROBERT E. DUDLEY, AUCTIONEER PHONE HOWELL (517) 548-3145... GREEN CAR, Multi-family, 2 1/2 cars, Bath, 2 cars...

117 Office Supplies and Equipment... CANON copier, HP550, 30 copies per minute, excellent...

117 Office Supplies and Equipment... CANON copier, HP550, 30 copies per minute, excellent...

117 Office Supplies and Equipment... CANON copier, HP550, 30 copies per minute, excellent...

120 Farm Equipment 120 Farm Equipment
BACKHOE 3 point hookup for tractor. Good condition. \$2,200. Hobart generator. Needs repair. \$500.

151 Household Pets
FOREIGN Lihac cat, with papers, registered. \$50.
GAMER, female. \$50.
KORNER, female. \$50.

152 Horses & Equipment
BOARDING, indoor arena with outdoor. Excellent. Large outdoor arena.
HORSE TRAILER for sale. 6'6" high. Very good condition.

153 Farm Animals
2 REGISTERED Polled Hereford Cows, calves at age. \$650 each pair.

154 Pet Supplies
AQUARIUM, 29 gallon wood stand, leader, \$85.

155 Animal Services
K-9 Design, grooming, days, evenings, weekends.
AIRLINES Reservations. Full hourly benefits.

REACH OVER 165,000 POTENTIAL CUSTOMERS EVERY WEDNESDAY AND 136,000 EVERY MONDAY
HOUSEHOLD SERVICES BUYERS DIRECTORY

Accounting, Asphalt, Brick, Block, Cement, Building & Remodeling, Bulldozing, Clean up & Hauling, Excavating, Excavating, Fencing, Landscaping, Landscaping, Landscaping, Landscaping, Painting & Decorating, Pole Buildings, Roofing & Siding, Roofing & Siding, Tree Service.

156 Clerical
All level Clerical positions available. Apply: 7745 West Grand River, Brighton.

157 Clerical
Clerical help wanted. Full time, experienced preferred.

158 Clerical
BOOKKEEPER, immediate opening. Apply in person at 301 Brighton Road.

REACH OVER 165,000 POTENTIAL CUSTOMERS EVERY WEDNESDAY AND 136,000 EVERY MONDAY
HOUSEHOLD SERVICES BUYERS DIRECTORY

Accounting, Asphalt, Brick, Block, Cement, Building & Remodeling, Bulldozing, Clean up & Hauling, Excavating, Excavating, Fencing, Landscaping, Landscaping, Landscaping, Landscaping, Painting & Decorating, Pole Buildings, Roofing & Siding, Roofing & Siding, Tree Service.





## Beat The Heat With One Of Don's "Cod" Used Car Deals

Price Buster of the Week  
87 AMC ALLIANCE  
1 Dr., 8,000 Miles, Special Purchase Car, Loaded, Factory Warrant.  
**\$5795**

'79 CADILLAC SEVILLE 4 Dr. <b>\$3995</b>	'87 CHRYSLER LEBARON GTS Loaded, Premium <b>\$8595</b>
'86 AMC ALLIANCE DL 4 Dr., Auto, Air, Only 30,000 Miles <b>\$3995</b>	'83 FORD LTD 27,000 Original Miles <b>\$3995</b>
'85 DODGE DAYTONA 1 <b>\$4995</b>	'87 CHEVY K-5 SILVERADO Full-Size Blazer, Mint Cond. <b>SAVE BIG</b>
'87 DODGE CARAVAN LE Loaded <b>\$13,500</b>	'83 RENAULT FUEGO <b>\$2495</b>

**We Have Over 10 Quality Used Cars Under \$3000**  
Hurry While They Last!

**We Buy Clean Used Cars**  
**BRIGHTON CHRYSLER**  
PLYMOUTH • DODGE  
9827 E. Grand River 229-4100  
"Home of the Price Buster"

# SAVE BIG

ON ALL CARS IN STOCK  
OVER 100 BUICKS & OLDSMOBILES TO CHOOSE FROM  
NO TRICKS - NO GIMMICKS - JUST LOW PRICES

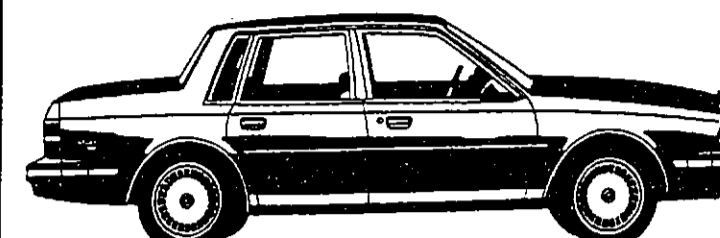

**BUICK 1988 CENTURY - 4 DR**  
V-6, Auto, A/C, Loaded  
LIST: \$14,411  
SALES PRICE \$12,788  
REBATE -\$500  
YOUR PRICE **\$12,288\***

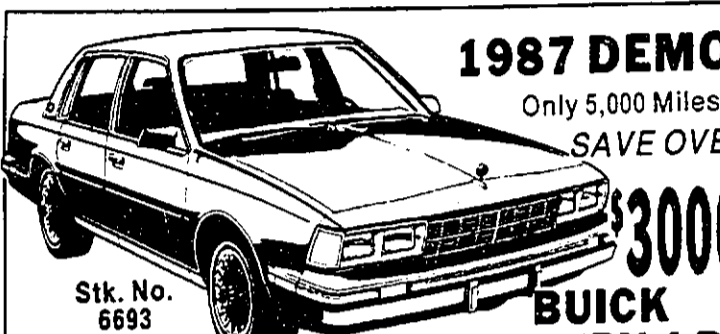

**1987 DEMO** Only 5,000 Miles  
SAVE OVER **\$3000!**  
**BUICK CENTURY 4 DR**  
Stk. No. 6693

## FEIGLEY MOTOR SALES

750 G.M. Road, Milford  
**684-1414**  
\*Just add 4% sales tax, title & transfer

## La Fontaine

### JEEP/EAGLE INC.

"Jeep Is Not Sideline With Us... Neither Is Service"

## NOW OPEN TO EARN YOUR BUSINESS!

Sales Hours: Mon & Thurs 9am-9pm; Tues, Wed & Fri 9am-6pm

# HUGE \$\$\$ SAVINGS

COUPON  
For Additional Savings Present This Coupon After You've Made Your Best Deal  
**\$300**

An Additional **\$300 to \$1,000** Chrysler Cash Rebates On Most Models

**NEW 1988 Jeep Comanche Pick-Up**  
Only **\$185.65\***/Mos.

**Large Selection Of Cherokees & Premiers to Choose From at Low Prices**

**NEW 1988 Jeep Wrangler**  
Only **\$234.96\***/Mos.

**NEW DEALER - LARGE INVENTORY!**

**SERVICE -**  
AES Certified Technicians  
Complete Stock of Chrysler Parts & Accessories  
We Service All Chrysler Products

**SERVICE DEPT. HOURS:**  
Monday 7:30am-9:00pm  
Tues thru Fri 7:30am-6:00pm  
115 E. Liberty, Milford  
**(313) 684-1485**

Only 22 Min. from Howell  
Only 15 Min. from Brighton & Holly  
Only 15 Min. from S. Lyon & Novi  
Only 20 Min. from Northville



## THIS WEEKS SPECIAL

# 1984 T-BIRD

Only **\$3300**

1980 MUSTANG HATCHBACK Very Clean Only <b>\$1900</b>
1986 MERC LYNX 2 DR 5Spd., Stereo Only <b>\$2800</b>
1983 FORD F-150 PICKUP Auto, P.S., P. Only <b>\$4100</b>
1984 OLDS TORO V-8, Full Power Only <b>\$4600</b>
1984 MERC GRAND MARQ. LS 4 DR Loaded Only <b>\$5800</b>
1985 MUSTANG HATCHBACK 4 Cyl., Air, Auto, Stereo, Low Miles Only <b>\$5900</b>
1985 FORD PICKUP F-250 Auto, Air Only <b>\$6900</b>
1986 CHRYSLER LEBARON 4 Dr., Full Power, Tilt, Cruise, Stereo Only <b>\$6700</b>
1987 LYNX STA-WGN Air, P. Steering, P.B., Stereo, Tu-Tone, 8,000 Miles Only <b>\$6700</b>
1985 MERC. GRAND MARQUIS 4 Dr., L.S., Blue Only <b>\$6900</b>
1984 TBIRD Auto, Air, Full Power, Stereo Only <b>\$6900</b>
1985 FORD CROWN VICTORIA 4 DR Full Power, Tilt, Cruise Only <b>\$6800</b>
1985 COUGAR Auto, Air, Full Power, Tilt, Cruise, Red Ext & Int. Only <b>\$6900</b>
1987 TEMPO 4 DR'S Auto, Air, Stereo Only <b>\$6900</b>
1985 CADILLAC CIMARRON V-8, Full Power, Leather D'Or Package, Low Miles Only <b>\$7900</b>
1985 MUSTANG GT Air, 5 Speed, Tilt, Cruise, Full Power, Moon Roof, 28,000 Miles Only <b>\$7900</b>
1983 FORD CLUB WAGON 8 Pass., Tu-Tone, Captains Chairs, Tilt, Cruise, Air Only <b>\$8800</b>
1986 MUSTANG GT T-Tops, Loaded Only <b>\$8900</b>
1987 FORD RANGER SUPERCABS 4x4 PICKUP Only <b>\$9600</b>
1985 GMC S-15 JIMMY 4x4 Loaded, Mint Cond. Only <b>\$9900</b>
1987 FORD PICKUP F-150 4x4 6 Cyl., 5 Spd., Stereo Only <b>\$10,600</b>
1987 MERC. GR. MARQUIS. 4 DR. LS Every Option, Under Fact. Warr. Only <b>\$11,900</b>
1986 BRONCO II XLT Air, Auto, Tu-Tone, Stereo Only <b>\$11,600</b>
1987 CAMARO Z-28 T-Tops, Full Power, Air, 16,000 Miles Only <b>\$12,900</b>
1985 BMW 325 E 4 DR. Very Clean, Loaded Only <b>\$14,900</b>
1987 LINC TOWN CAR Sign Series, Leather Int., Computer Dash, Loaded Only <b>\$17,900</b>

**HUGE SAVINGS ON DEMOS**

## AT VARSITY FORD YOU SAVE BIG WITH OUR...

# LOW PRICES

EVERYDAY PRICES ARE OVER 1400 CARS, TRUCKS & VANS IN STOCK

**NOBODY SELLS FOR LESS**

**BUY AT OUR GREAT LOW PRICES OR - NO DOWN PAYMENT LEASE '88 AEROSTAR WAGON 7 PASSENGER**  
20 V-6 F.I. Auto, Overdrive, P.S., P.B., P234 14 85W All-Season, Shred Wheels, Speed Control, Tilt, Air, Power Windows, Chrome Bumper, Air Cond., Power Dials, Elec. Defrost, Near Wiper & Washer. Stk. No. 6424

'88 FESTIVA "L" 3 Door <b>\$5490*</b>	'88 TEMPO "GL" 2 Door <b>\$8290*</b>	'88 MUSTANG "GT" 3 Door <b>\$13,390*</b>	'88 MUSTANG "LX" 2 Door <b>\$7790*</b>
'88 TEMPO "GL" 4 Door <b>\$8090</b>	'88 EXP SPORT COUPE <b>\$7890*</b>	'88 ESCORT GT 3 Door <b>\$8790*</b>	'88 F-150 PICKUP XLT LARIAT <b>\$12,190*</b>
'88 TAURUS "L" STATION WAGON <b>\$11,790*</b>	'88 BRONCO II XLT <b>\$11,190*</b>	'88 ESCORT "GL" STATION WAGON <b>\$7990*</b>	'88 ESCORT "GL" 4 Door <b>\$6990*</b>

**ATTENTION SHOPPERS**  
We will locate the vehicle of your choice from Michigan, Indiana, Ohio Free of Charge  
A-X-Z Plans Welcome

**OR LEASE "0" DOWN FOR 127\*** **OR LEASE "0" DOWN FOR 189\*** **OR LEASE "0" DOWN FOR 276\*** **OR LEASE "0" DOWN FOR 176\***

**OR LEASE "0" DOWN FOR 187\*** **OR LEASE "0" DOWN FOR 175\*** **OR LEASE "0" DOWN FOR 199\*** **OR LEASE "0" DOWN FOR 264\***

**OR LEASE "0" DOWN FOR 249\*** **OR LEASE "0" DOWN FOR 245\*** **OR LEASE "0" DOWN FOR 176\*** **OR LEASE "0" DOWN FOR 166\***

**OR LEASE "0" DOWN FOR 163\*** **OR LEASE "0" DOWN FOR 222\***

**'88 RANGER "XLT" PICKUP** **'88 F-450 SUPER DUTY**  
**\$7190\*** **\$12,990\***

**'88 F-250 PICKUP** **'88 RANGER "S" PICKUP**  
**\$9,290** **\$6690\***

**OR LEASE "0" DOWN FOR 198\*** **OR LEASE "0" DOWN FOR 164\***

## Try one on for size.



Comanche's up to the challenge. And that's the long and short of it.

- 121 hp fuel-injected engine standard
- 4-speed manual transmission standard on shortbed models. 5-speed manual standard on longbed models.
- 15-inch all-weather steel-belted radials
- Power front disc/rear drum brakes
- Wide choice of models. 2- or 4-wheel drive, in shortbed or longbed
- Quadra-Link front suspension
- Available option 177 hp 4-litre Power-Tech Six engine. Far more powerful than anything in its class

Only in a Jeep

**OVER 20 NEW COMMANCHES IN STOCK** From **\$6923\*** ONLY  
Stk. No. 8751

**USA**  
Jeep

## HIGHEST \$\$\$ TRADE-IN

# 3480 JACKSON AT WAGNER ANN ARBOR I-94 EXIT 172

MON. & THURS. 9 to 9, TUES., WED., FRI. 9-6, ANN ARBOR 996-2300 CLOSED SAT. 'TIL SEPT.

## WALDECKER

7885 W. Grand River • Brighton  
**227-1761**  
HOURS: Mon & Thurs. 9 am to 9 pm  
Tues., Wed., & Fri. 9 am to 6 pm  
\*Net Price After Rebate Plus Tax, Title, Plates & Destination Charges

**HILLTOP FORD**  
LIVINGSTON COUNTY'S NO. 1 USED CAR DEALER  
(517)546-2250 AT THE TOP OF THE HILL Howell

Hilltop Ford, Inc. 20th Anniversary Howell, Michigan 1968 1988



### USED CARS? OR NEW?

You Can't Tell The Difference at Bill Brown Ford

We take pride in investing extra time and money in our used cars so you don't have to.

I Love my Bill Brown Ford

- Tempo "0" Down"
- Mustangs "0" Down"
- T-Birds "0" Down"
- Taurus "0" Down"
- Escorts "0" Down"
- Vans "0" Down"
- Pick-Ups "0" Down"

Reconditioned • Guaranteed • Priced to sell  
It's worth the 20 minute drive for high quality & low prices  
\*Plus tax & license on approved credit

**BILL BROWN FORD**  
522-0030

3500 Plymouth Rd.  
4 min. E. of 275

### 250 Bargain Barrel

Shredded peat, \$2.00 per bag, also by the yard. (313)299-2522

FENTON Office site 100X153 with sewer, water, gas available. Only \$15,900 cash. Call Jerry or Cheryl 1-800-544-2776, RE/MAX Suburban. (1056)

BARLEN CONTRACTING

Building back fill, rough and finished grading, 22 years experience. References available. Master Card and Visa.

BARLEN CONTRACTING

SEPTIC SYSTEMS. Perk tests, 22 years experience. References. Master card. Visa. (313)747-6666.

FURNITURE stripping and refinishing. Call Bob. (517)546-7784 or (517)546-6875.



**ONLY YOU**

## \$300 REBATES

### 1988 PLYMOUTH HORIZON



#### 5 Door Hatchback

- Power Brakes
- Rear Defroster
- Tinted Glass
- Intermittent Wipers
- Rear Wiper/Washer
- Rally Type Instrumentation
- 2.2 Electronic Fuel Injection
- 5 Speed Transmission
- Cloth Seats
- All Season Radial Tires
- Rally Wheels
- Rear Security Shelf
- Visor Vanity Mirror
- Sport Steering Wheel
- Trunk Dress Up
- And Much, Much More!

18 To Choose From! **\$2875\*** Sold At Dealer Invoice!

**BRIGHTON CHRYSLER**  
PLYMOUTH • DODGE

9827 E. Grand River  
**229-4100**

\*Includes Taxes, Transfer, Based On 10% Down Payment, 8.9% APR For 60 Month.

Sharing's Caring

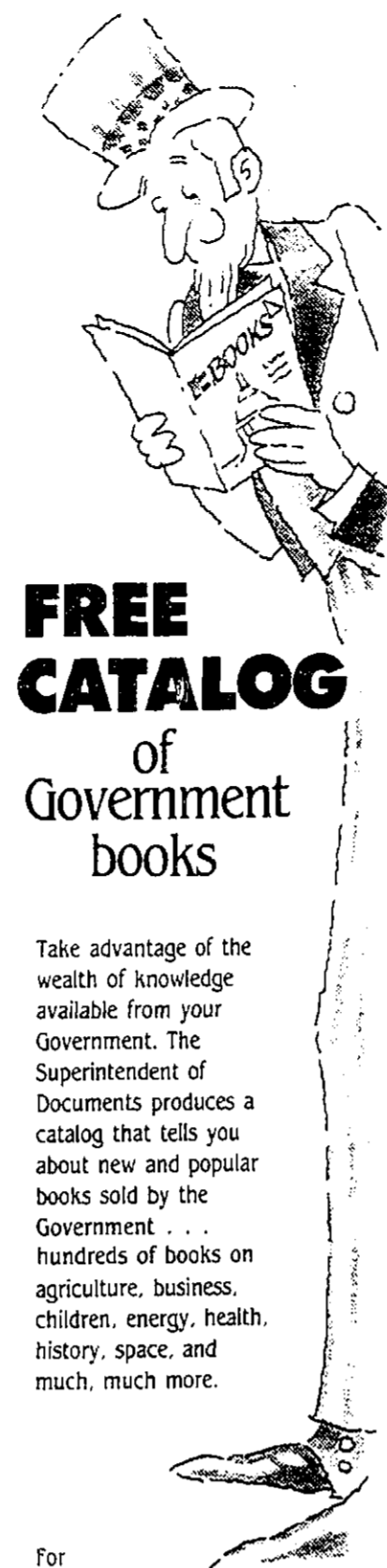

### FREE CATALOG of Government books

Take advantage of the wealth of knowledge available from your Government. The Superintendent of Documents produces a catalog that tells you about new and popular books sold by the Government—hundreds of books on agriculture, business, children, energy, health, history, space, and much, much more.

For a free copy of this catalog, write—  
Free Catalog  
P.O. Box 37000  
Washington, DC 20013-7000

### THINK SNOW? NO FOOLING-IT'S COMING!

BEAT THE PRICE INCREASE THAT COMES WITH IT

**BUY NOW & SAVE!!**



<b>'86 DODGE POWER RAM 4x4 WITH FLOW</b> 4.0L V6 160 HP P.B. 2.0L Turbo Diesel 1000 Miles 3.90 Miles, 20 1/2" tires 7.9L New Power Steering, Power Lock Compressor, Power Side Windows TODAY'S PRICE \$10,988 OCTOBER 1st... \$11,988	<b>'86 DODGE RAM CHARGER 4x4</b> 4.0L V6 160 HP P.B. 2.0L Turbo Diesel 1000 Miles 3.90 Miles, 20 1/2" tires 7.9L New Power Steering, Power Lock Compressor, Power Side Windows TODAY'S PRICE \$11,988 OCTOBER 1st... \$12,988	<b>'84 DODGE RAM CHARGER 4x4 WITH FLOW</b> 4.0L V6 160 HP P.B. 2.0L Turbo Diesel 1000 Miles 3.90 Miles, 20 1/2" tires 7.9L New Power Steering, Power Lock Compressor, Power Side Windows TODAY'S PRICE \$9,988 OCTOBER 1st... \$9,988
--	--	--

**BRIGHTON CHRYSLER**  
Plymouth-Dodge  
**HOWELL USED CAR**

904 E. Grand River • Howell  
Next to Anthony's Restaurant  
**517-548-5190**

### theNOVI NEWS

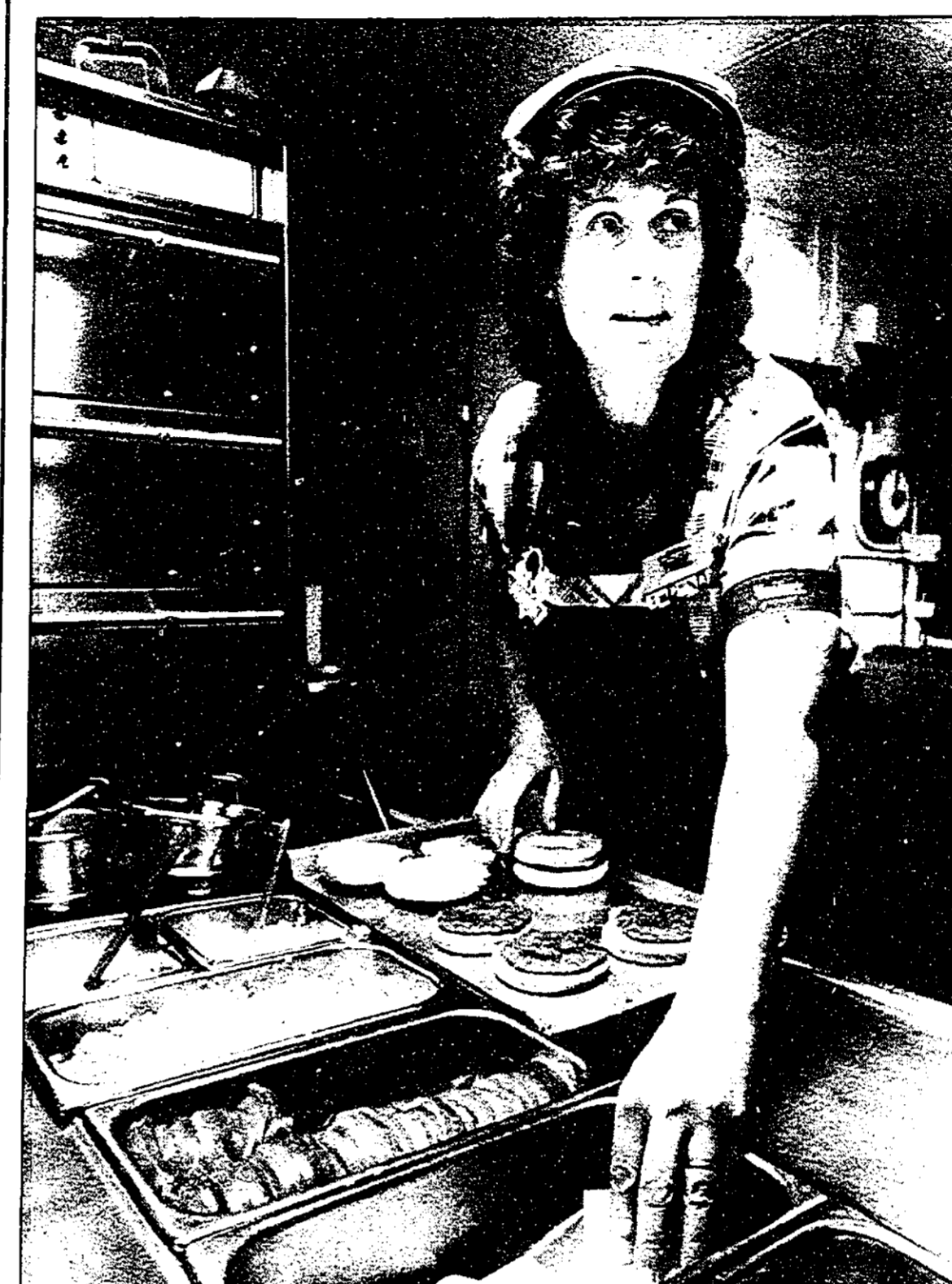

**GEARING UP:**  
Athletic Boosters prepare for new season/2C

**AT THE MARQUIS:**  
Theater announces fall production series/3C

**CONCERT BAND:**  
Novi Concert Band to perform Friday night/4C

**EATING 'OUT':**  
Local restaurants offer outdoor cafes/5C

**1C**  
THURSDAY  
July 28,  
1988



Left, senior worker Barb Wolfelt at her job at Northville's Hardee's. Above, Burt Johnson delivers meals to shut-ins.

## BACK TO WORK for senior citizens

By PHIL GINOTTI staff writer

They show up on time. They catch on quickly. They work ambitiously, dedicated employees, endowed with a work ethic that's all but dead now. It's a legion who learned the value of a buck when there weren't many around. They're well-educated. They're downright old-fashioned folks.

All of that explains pretty well why local fast food restaurants, hardware stores, offices, and the like are clamoring to find them and get them on board. That group includes empty-nesters, senior citizens, or mothers who perhaps want a little bit more than "life-at-home" when the children are away at school.

They'll swing back into action this fall, taking their spots in the



Dorothy Black and Glyda Barend, right, check statistics

kitchen, behind the counter, or out on the sales floor. They'll take the spots usually held by lousy-chinned teenagers or struggling college students. They'll do what many local employers are afraid to admit... a much better job.

Hiring the "older worker" has been a part of the local job scene for years and years, though it's just recently become highly visible. Any daytime trip to a local McDonald's or mall retail store confirms that.

The Oakland County senior citizen population increased 55 percent from 1970 to 1980. There are over 149,000 in the county with more than a third either in the job market or willing to work.

"This is something that's not news to McDonald's," Regional Marketing Supervisor Jan DiNezza said. "We've been hiring senior citizens for years and years."

And according to DiNezza, the

partnership has been a good one, spurred in recent years by well-crafted McDonald's television advertising.

"Bill" is what did it," she said, referring to the quaint "New Kid" commercials which ran last year.

In "New Kid" a silver-haired old gent passes on his friends' invitation to go fishing and instead saunters off "to work," much to their surprise. Work is at a McDonald's restaurant.

"We've got more requests from the media because of that commercial," DiNezza said. "Are we on a senior citizen recruiting program? The answer is no. It was never intended to be that."

"It's just a good commercial," she added. "We've had an overwhelming positive response."

Nonetheless, the "older workers" have definitely become a focal point at McDonald's and other fast food

restaurants, where they are perhaps most visible.

"They're more dependable and they definitely help to fill out the day schedule," said Wixom McDonald's manager Kathy Klink. "We get the full range—30s, 40s, 50s on up. You'll begin seeing a lot more of them during the fall months."

Northville Hardee's manager Susan Mishler said probably more than half of the restaurant staff will be made up of workers over 40 when the school year rolls around.

"They're generally very reliable and the quality of the work is very good," Mishler said. "Many will take the summers off."

Black's Hardware manager Donna Black has a problem of a different sort. They want the seniors, but can't get enough.

"I like it," she said. "These are things all of these people have done

before. On a nice day, the kids just take off.

And each day they go off to work, they bust another myth about "the older worker."

To the person, local business operators scoffed at criticisms associated with older workers—that they miss more time because of illness, that they can't adapt, that they are too slow to handle today's modern tasks.

"If you want to come spend a day with them, they'll wear you out," DiNezza said.

Novi Senior Center coordinator Jan McAlpine employs three senior citizens on a part-time basis.

"They can spell, they can add figures," she said. "It's no wonder that they've become very valuable to employers."

"They just have a younger attitude, that's all," McAlpine said.

# McDONALD FORD

## HERE TODAY! GONE TOMORROW! INVENTORY REDUCTION SALE

<b>1988 ESCORT STATION WAGON</b> Automatic Transmission, Power Windows, Power Steering, Power Locks, Power Mirrors, Power Side Windows, Dual Rear Seats, Dual Side Mirrors, Dual Side Windows, Dual Side Mirrors, Dual Side Windows, Dual Side Mirrors Was \$10,246 Discount \$700 Rebate \$1700 Now <b>\$7999*</b>	<b>1988 EXP</b> Automatic Transmission, Power Windows, Power Steering, Power Locks, Power Mirrors, Power Side Windows, Dual Rear Seats, Dual Side Mirrors, Dual Side Windows, Dual Side Mirrors, Dual Side Windows, Dual Side Mirrors Was \$10,246 Discount \$700 Rebate \$1700 Now <b>\$8199*</b>	<b>1988 TEMPO GL 4 DOOR</b> Automatic Transmission, Power Windows, Power Steering, Power Locks, Power Mirrors, Power Side Windows, Dual Rear Seats, Dual Side Mirrors, Dual Side Windows, Dual Side Mirrors, Dual Side Windows, Dual Side Mirrors Was \$10,246 Discount \$700 Rebate \$1700 Now <b>\$8599*</b>	<b>1988 T-BIRD</b> Automatic Transmission, Power Windows, Power Steering, Power Locks, Power Mirrors, Power Side Windows, Dual Rear Seats, Dual Side Mirrors, Dual Side Windows, Dual Side Mirrors, Dual Side Windows, Dual Side Mirrors Was \$10,246 Discount \$700 Rebate \$1700 Now <b>\$12,699*</b>
--	---	---	--

<b>1988 FESTIVA</b> Was \$17,671 Now <b>\$5499*</b>	<b>1988 T-BIRD LX</b> Was \$17,671 Now <b>\$13,599*</b>	<b>1988 F150</b> Was \$11,510 Now <b>\$8799*</b>
<b>1988 E350 CUBE VAN</b> Was \$18,066 Now <b>\$15,999*</b>	<b>1988 NIGHTOP CONVERSION VAN</b> Was \$27,725 Now <b>\$19,999*</b>	<b>1988 TAURUS LX 4 DR</b> Was \$17,587 Now <b>\$13,499*</b>
<b>1988 BRONCO</b> Was \$21,156 Now <b>\$17,999*</b>	<b>1988 RANGER SUPER CAB</b> Was \$10,924 Now <b>\$8299*</b>	<b>HUNDREDS MORE NEW CARS, TRUCKS, VANS IN STOCK NOW FOR IMMEDIATE DELIVERY</b>

Visit our new display area at 7 Mile and Sheldon Road  
**349-1400**  
550 W. 7 Mile Northville  
Conveniently located between Northville Rd. & Sheldon Rd. minutes west of I-275

### Random Sample

- Q: What is your favorite ice cream flavor?
- One said: "Mint chocolate"
  - One said: "Lemon custard"
  - One said: "Butter pecan"
  - One said: "Heavenly hash"
  - One said: "French vanilla"
  - Five said: "Chocolate"

Random Sample is an unscientific poll of 10 Northville/Novi area residents conducted by the staff of this newspaper.



Volunteer Betty Griffin

### Volunteer helps at local college

By DOROTHY NASH special writer

When a woman of any age suddenly loses her financial support, through death or divorce, she knows she has to do something about it, but doesn't always know what.

And that's where Schoolcraft College's Women's Resource Center comes in with a volunteer peer counselor like Betty Griffin providing someone with whom to talk.

Griffin is in the office, located at the College, for three hours one morning of the five days a week the service is available.

"There are usually two of us there at a time," Griffin said. "One of us answers the phone, and the other handles walk-ins."

The typical clients are women who need to talk about their problems, which primarily include bereavement, divorce, and lack of education in a marketable skill, she

said. Sometimes the problems are complex and the women have difficulty sorting through them.

"As a peer counselor I try to understand what a woman is saying," Griffin said, and then tries to help her look at all of the factors and offers her solutions.

In the office where Griffin sits there is a large bulletin board to which she refers. It lists all of the available information on a variety of support groups plus information on Michigan Department of Labor programs such as Apprenticeship for Women and the Displaced Homemaker Program.

Betty Griffin admitted that peer counseling volunteering isn't for everyone. She found that out when she took the required 48-hour empathy training course three years ago.

If you are interested in peer counseling volunteering, call 591-6400 ext. 430 for information.





# The Switch Is On To Farmer Jack!

- VANILLA
- CHOCOLATE
- MAPLE NUT
- NEAPOLITAN
- FUDGE REVEL
- CHERRY VANILLA

FARM MAID

**Ice Cream**

**99¢**

1/2-GAL. CTN.

PEPPERONI

• SAUSAGE 10.8 OZ.

• PEPPERONI 10.3 OZ.

**CRISP 'N TASTY**

JENO'S FRESH FROZEN

**Crisp 'N Tasty Pizza**

**97¢**

EA. PKG.

SEMI-SWEET MORSELS

**Nestle**

NESTLE SEMI-SWEET

**Chocolate Morsels**

**\$1.77**

12-OZ. BAG

ORANGE JUICE

FARM MAID 100% PURE FLORIDA

**Orange Juice**

**\$1.37**

1/2-GAL. CTN.



ALL BEEF

## Hamburger

**89¢**

ANY SIZE PKG. LB.

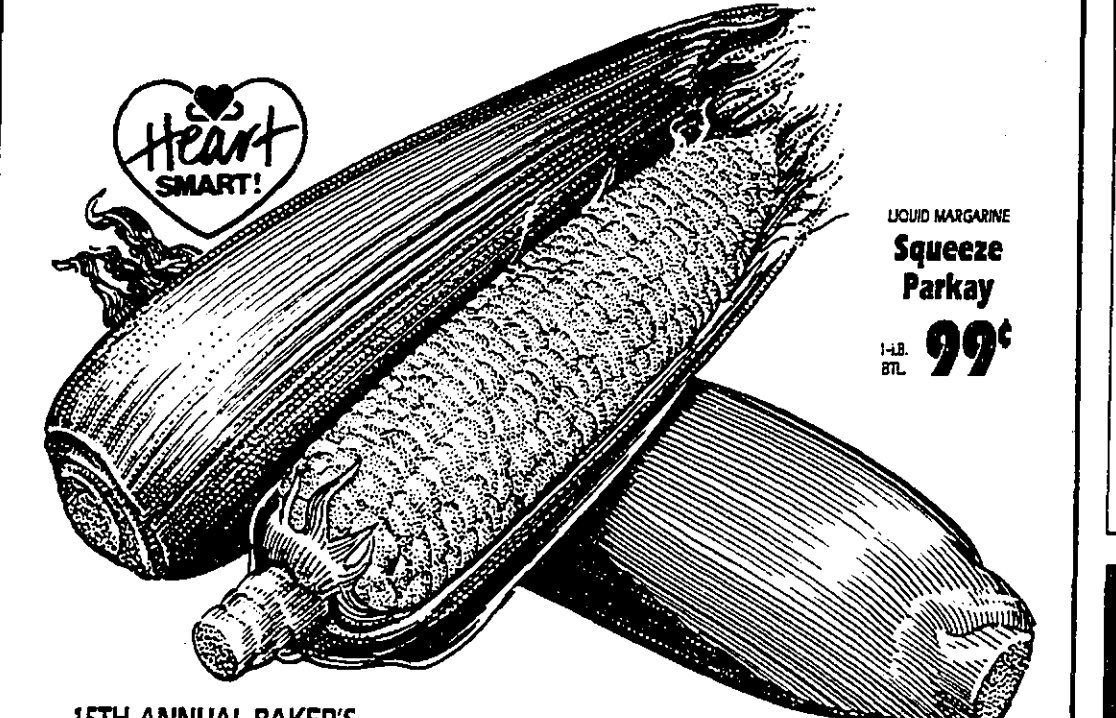

15TH ANNUAL BAKER'S DOZEN CORN SALE!

**Sweet Corn**

**13 EARS IN HUSK \$1.79**

**FARMER JACK**

**SUPERMARKETS**

U.S.D.A. CHOICE BEEF

**Q.L.T. Rib Steak**

**\$2.48**

LB.

BORDEN LOWFAT BUTTERMILK OR

**Chocolate Milk**

**97¢**

1/2-GAL. CTN.

CHEF BOY-AR-DEE PASTA DINOSAURS.

**ABC's or Tic-Tac-Toe's**

**44¢**

15-OZ. CAN

REG. OR DIET: ORANGE SLICE, LEMON-LIME SLICE, A & W ROOT BEER

MOUNTAIN DEW, VERNORS, PEPSI-FREE OR

**Pepsi-Cola**

**88¢**

2-LITER BTL. PLUS DEP.

Prices effective through Saturday, July 30. We reserve the right to limit quantities to specified amounts. No sale to dealers, restaurants or institutions.

## Schram, Osborne ready for all-star game

By NEIL GEOGHEGAN  
Staff writer

On July 30, Novi's Brian Schram will wrap up a brilliant high school athletic career in style — at the 1988 Michigan High School East-West All Star Football Game in East Lansing.

For Schram, being named to the team was a great honor and thrill. He will be joining 79 of the premier senior football players from across Michigan in the most prestigious all-star game sanctioned by the Michigan High School Athletic Association (MHSAA).

Schram will long be remembered as a versatile athlete who starred as a wide receiver and quarterback for John Osborne's two Kensington Valley Conference (KVC) championship teams in 1986 and '87. He also was one of the area's top basketball centers and one of the county's premier high jumpers.

"This is the first all-star game I've played in and I'm a little bit nervous," Schram acknowledged. "I think most of it is excitement, but I really don't know what to expect competition-wise."

Despite leading the Wildcats to within an eye lash of the state Class A title last fall as quarterback, Schram is officially listed on the East squad roster as a wide receiver. At 6-foot-6, Schram is a big target with good hands and surprisingly agile moves. And catching the ball isn't very foreign to him. As a junior, Schram was a first-string receiver for Novi and a second-string quarterback. He led the team in receiving touchdowns that year and was an All-Area selection.

"I'm not sure why I'm a wide receiver instead of quarterback — I'm just glad to be going," he said. "In my senior year, if we'd had another quarterback instead of me, I would have liked to remain a wide receiver. I like catching the ball more than throwing it."

Schram should have an advantage on the East team because Osborne is the East head coach. Playing for your high school coach in a game like this can have many advantages: knowing the playbook, catching the coach's eye, familiar coaching techniques and the like.

"I've been looking at the playbook and getting football back

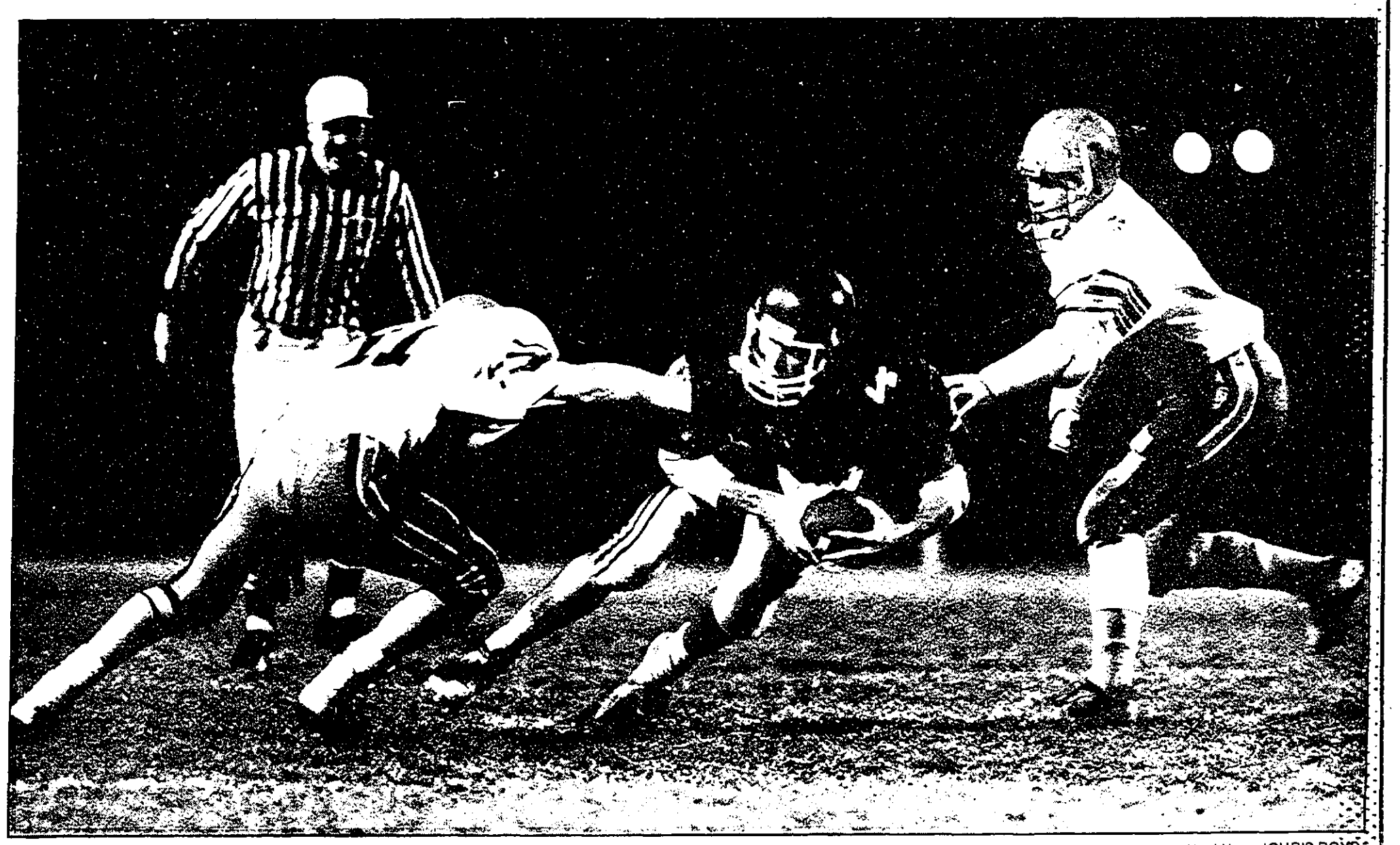

Former Wildcat QB Brian Schram has been selected as a wide-receiver on the East All-Star team Saturday

in my mind for a while now," Schram pointed out. "The playbook is very similar to what we had at Novi so it's definitely an advantage for me. Coach Osborne knows what I can do so hopefully he'll put in a good word for me. Everyone is required to play half the game so I'm not worried about playing time."

Schram is planning to walk-on as a freshman football candidate at Michigan State this fall, and believes his performance in the all-star game can help. Being a star in many different sports in high school would lead most to believe that Schram had a hard time setting on

one sport to try in college, but it wasn't that way at all.

"It was an easy decision," he said. "I love basketball, but I don't see myself as a big-time college player at a place like MSU. But I feel I can contribute to the football team and I'm going to give it my best shot. I have talked to several MSU coaches, and they know I'm going to be playing in the game."

"I think (the all-star game) will help me — especially if I do well. Maybe the coaches will look at me more in the fall. I'll be out there trying to impress them."

Schram reported to Michigan State on July 21 and has been going through two-a-day practices ever since with his East teammates. The all-star game will be the eighth annual and will get under way at 1:35 p.m. at Spartan Stadium.

"I'm confident I'll do well," he said. "I want our team to win and I want to do well myself, and it all goes hand-in-hand. This will help me get a head start on conditioning, and I'm sure it will get me thinking more about football."

Schram has put on about 25 pounds since last fall because he

believes he'll need to get bigger and stronger to make it in the collegiate ranks. He currently tilts the scales at about 205 pounds, but still has a way to go before getting to the desired weight.

"I've been lifting weights this summer at Bob's Gym and it's helping out a lot," he noted. "I want to play at about 210, and I'm about five pounds under that right now. It's obtainable, but it won't be easy."

During Schram's varsity football career, he started 19 games as a junior and senior. The "Cats" had a remarkable 17-2 record during that

span. In addition, since Schram was brought up to the varsity ranks after his sophomore year, Novi did not lose a single KVC clash in 17 tries and grabbed back-to-back conference crowns.

"It's a great record, and I'm proud to be a part of it," he said. "The team unity was one of the keys. We were a family, and we put it all together, especially last fall. I honestly feel our team should have been the state champs, but I was glad to see the team that finally beat us (Ann Arbor Pioneer) go all the way."



Cabana third-sacker Brad Lewis gobbles up a bunt attempt

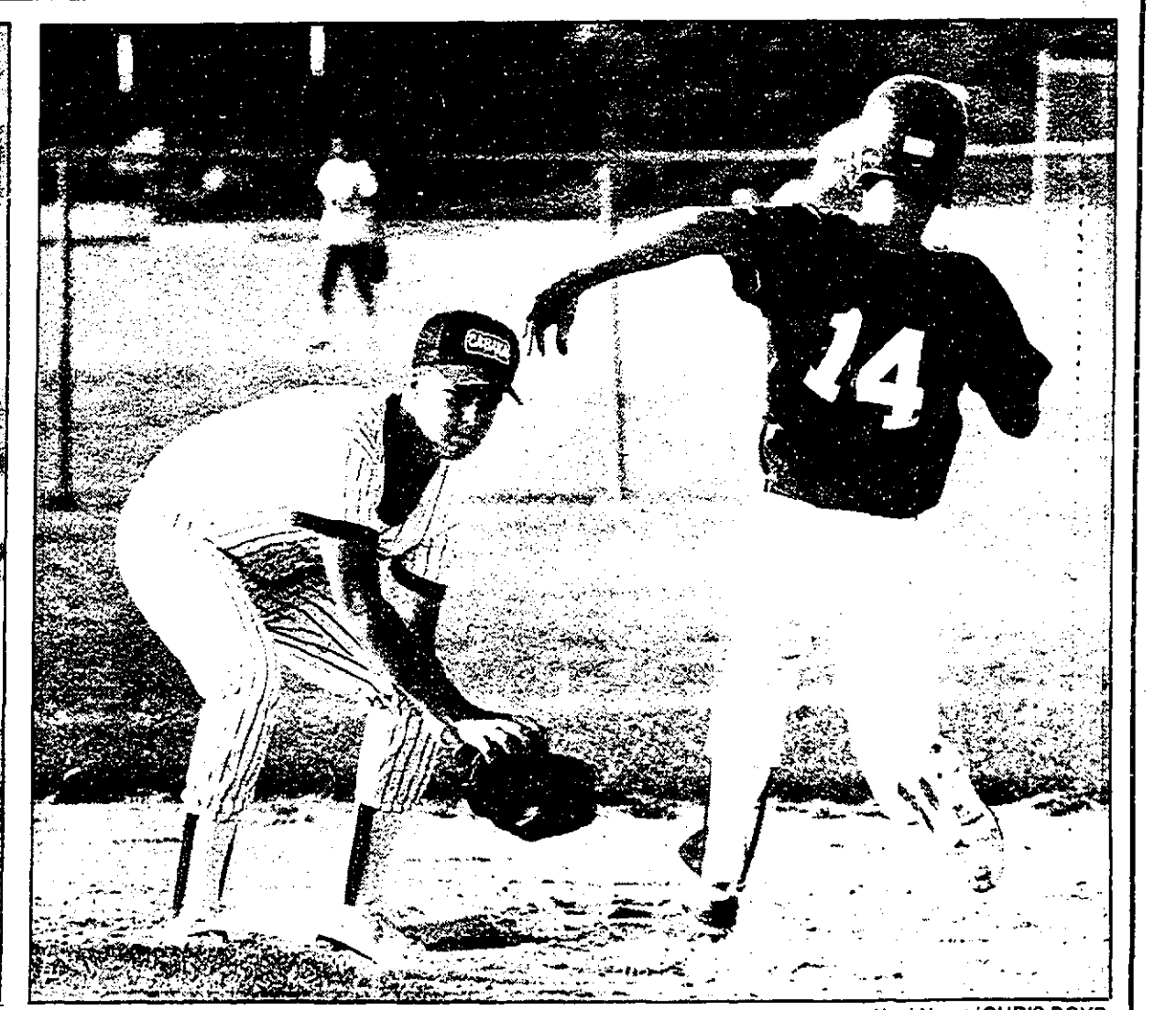

Shortstop Mark VanAmeyde waits to put the tag on an unsuccessful base-stealer

## Cabana nine falls just short in bid for play-offs

By NEIL GEOGHEGAN  
Staff writer

Novi Cabana — the city's entry in Mickey Mantle-level baseball — ended up winning five of its last six regular season games, but the final victory was a big let down.

Coach Russ Timreck said his team was sky-high in preparation for the season finale against Southfield on July 23, but the visiting team never showed up. It was officially logged as a 1-0 forfeit, but it was also an anticlimactic conclusion to a very promising campaign.

"It was a real bummer," Timreck said, "even though we got credit for a victory. I told Rick Friedrich he was going to be our starting pitcher, and he was primed and ready to go. So obviously he was very disappointed. Apparently, (Southfield) had four players hurt and couldn't field a team."

Cabana did have a conventional victory in action last week, as well as a loss, and ended the season with a 13-9

overall mark. The win was an impressive 5-3 decision on the road against a hard-hitting Livonia Churchill squad on July 21 and the big hero was starting pitcher Mark VanAmeyde who had a fine game on the mound and at the plate.

Cabana drew first blood in the top of the second as VanAmeyde singled and then scored on a double by Brian Bartz. In the third, Heath Ruck started another rally with a single and, after a base on balls, Rick Timreck drove in two runs with a double. VanAmeyde's base hit then scored Timreck to make it 4-0.

In the bottom of the third, Livonia lagged VanAmeyde for two runs, but Cabana came right back with a single run in the fourth on an RBI hit by Friedrich. Livonia added one in the seventh but it wasn't enough.

VanAmeyde went the distance and notched the win. He fanned seven, walked none and gave up just five hits. He also helped his own cause by going 2-for-3 at the plate. Darrel Krause also had two hits in the game.

"Churchill has some real fine hitters, but VanAmeyde-

prettly much kept them in check," said Timreck. "He's really come on strong in the latter part of the season."

**ALLEN PARK '3, NOVI 1:** This clash on July 19 was a pivotal game. Both teams were fighting for a berth in the NABF Regional Tournament, but it was Allen Park which broke a 1-1 tie with two runs in the final two innings to pull out the victory.

"This game was bad news for us," Timreck said. "If we'd have won this game, we would have been assured of a berth in the tournament."

Cabana drew first blood with a run in the first. Mark Clary led off with a single, advanced to second on a passed ball and scored on a hit by Matt Gdowski. Allen Park scratched in the tying run off Cabana starter Brad Lewis in the third on the strength of just one hit, and the score remained 1-1 until the sixth.

Allen Park strung together a single and a double to go ahead 2-1 and then added an insurance run in the seventh to close it out.

Lewis suffered the loss, but pitched fairly well. In seven innings of work, Lewis allowed just five hits and two earned runs while striking out 10.

"It was a tight game all the way," Timreck recalled. "Brad pitched a good game, we just didn't support him much offensively, even though we did out-hit them 5-5."

**TOURNAMENT NEWS:** The loss to Allen Park knocked Cabana out of tournament contention, but two standouts from the team were chosen in the post-season draft by squads which did qualify. The Taylor Mickey Mantle team picked Cabana infielder/pitcher Rick Timreck and catcher Brian Bartz to join them for the tournaments. Timreck and Bartz will play in the NABF regional tourney this week in Taylor.

"Taylor was 18-4 during the regular season so they are a very fine team," Russ Timreck said. "I was very happy to see them get drafted because I think they'll both do well."





# BUILDERS SQUARE<sup>®</sup>

HOME IMPROVEMENT WAREHOUSE

OWENS-CORNING  
FIBERGLAS

ATTIC BLANKET

EXPERT  
ADVICE...  
COME  
TALK TO  
US!

R-25  
8"x15"

31.25 SQ.  
FT.



8 FOOT  
TREATED 2 x 4'S

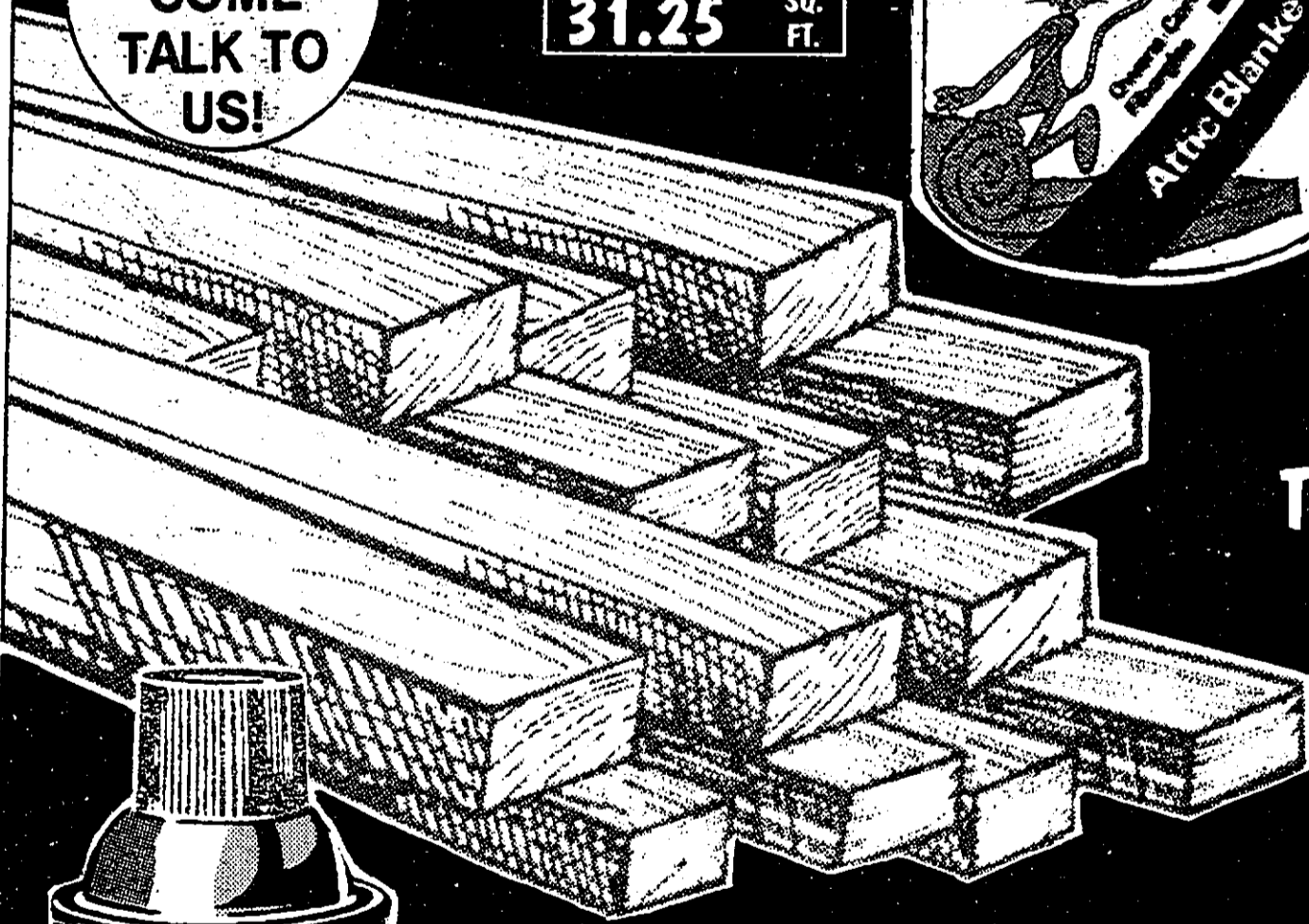

9 OZ.

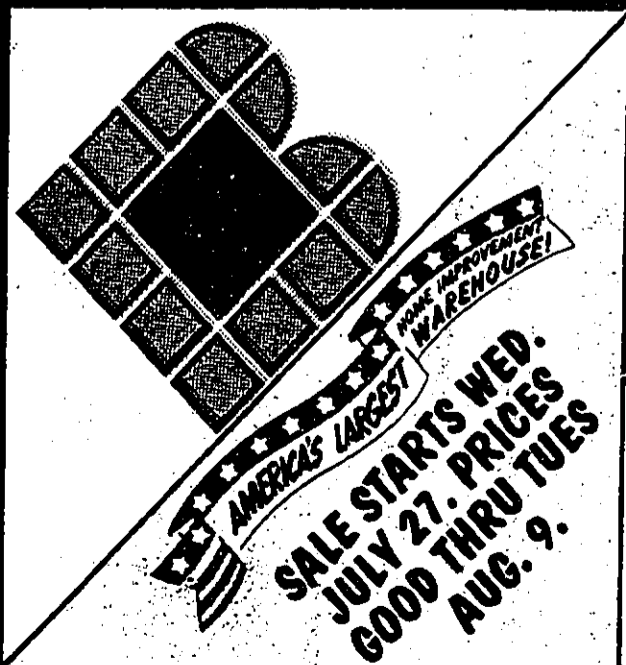



## WE'RE THE PROFESSIONALS THE PROFESSIONALS DEPEND ON

Professional contractors involved in daily home improvement and repair projects need the right product at the right price, right now. Their businesses depend on it! That's why they shop Builders Square, and so do thousands of home handymen and do-it-yourselfers. Because, whether you need two dozen light fixtures or just one... you'll find the biggest selection and lowest prices at Builders Square. Providing you the convenience of selection and savings is what we do best... our business depends on it!

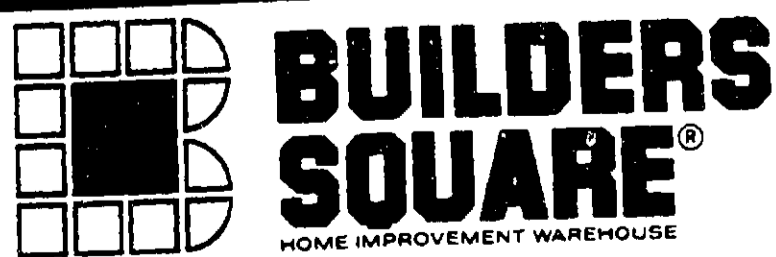

©1988 BUILDERS SQUARE  
 Limited quantities. Sorry, no rainchecks.  
 At least one of each item available in the  
 store at the beginning of the sale.

# LOWEST PRICES GUARANTEED!

Because we think you deserve the best quality home improvement products at the lowest possible price.

## YOU CAN'T BUY IT ANYWHERE FOR LESS...

## WE GUARANTEE IT!

We guarantee the lowest price on every item... every day! And, if you find a lower price at a competitor (Heaven forbid!) just let us know and we'll change it, plus we'll give you 10% more in SQUARE BUCKS for your next purchase. Identical items only (same manufacturer and model number). Offer limited to items in stock. No rain checks. Price comparisons are at time of purchase. We reserve the right to limit quantities to dealers and competitors.





# LOW WAREHOUSE PRICES!

**TUCKER HOUSEWARES**  
SUBSIDIARY OF KIDDE INC  
KIDDE

**TUCKER HOUSEWARES**  
SUBSIDIARY OF KIDDE INC  
KIDDE



**30 GALLON PLASTIC TRASH CAN**

**547**  
#229

- Tough, plastic construction resists heat, cold and abuse.
- Snap-lock cover.



**32-GALLON WHEELED TRASH CAN**

**997**  
BROWN

- Wheels provide greater mobility.
- 6 year warranty.

#701

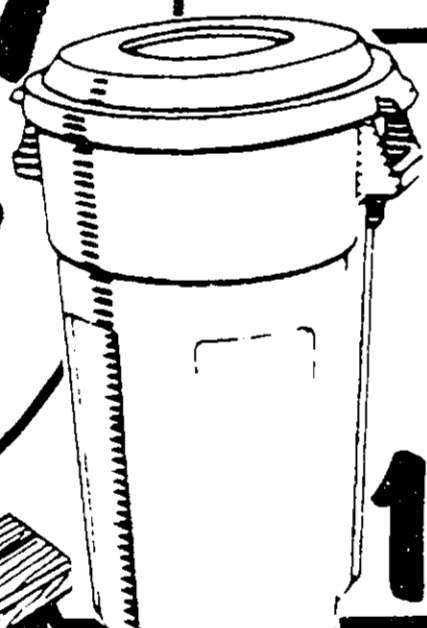

**Rubbermaid**  
**32-GALLON ROUGHNECK CONTAINER**

**1097**  
#2894

- Roughneck™ refuse container



**YOUR CHOICE!**

**13 GALLON TALL KITCHEN BAGS**  
OR  
**26-GALLON TRASH AND GRASS BAGS**

**188**  
• 35 ct.  
• Super tough trash cans.  
• Fits up to 13 gallon cans.  
• 25 ct.  
• Super tough trash bags.  
• Fits up to 26 gallon cans.

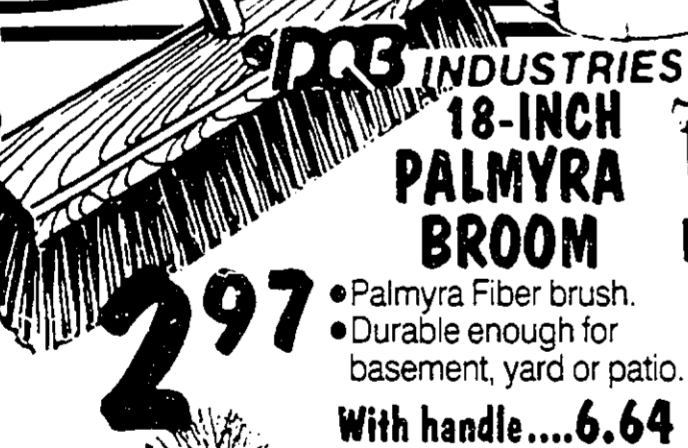

**36-INCH DUST MOP HEAD**

**\$16**

MOP WITH HANDLE 20oz.... 4.40  
ANGLE BROOM FLAGGED SYNTH.... 4.99

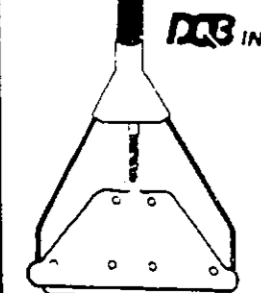

**60-INCH JANITOR MOP HANDLE**

**592**

16-INCH BLACK SWEEP WITH HANDLE ..... 5.57

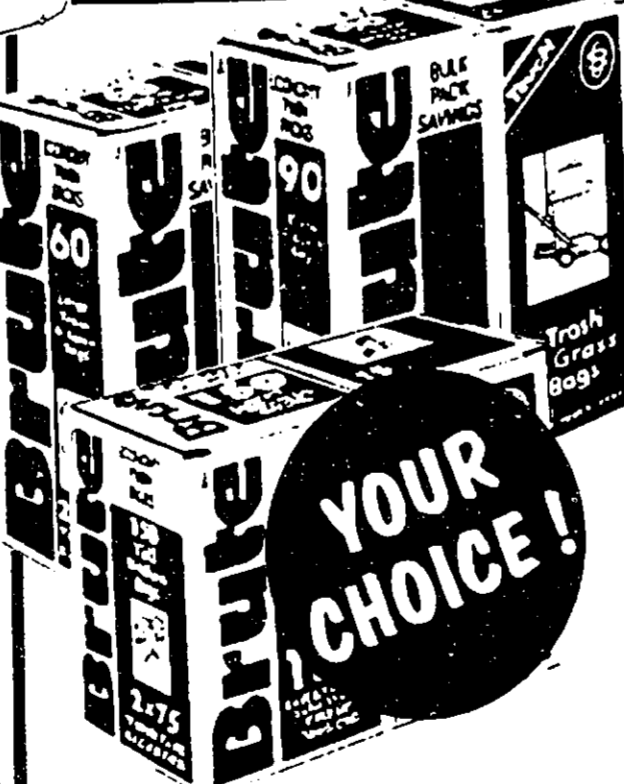

**13-GALLON TALL KITCHEN TRASH BAGS**  
**26-GALLON TRASH & GRASS BAGS**  
**33-GALLON TRASH & GRASS BAGS**

**477**  
EACH  
• Extra tough trash bags.  
• Easy open dispenser package.  
• 13 GAL- 120 CT.  
• 26 GAL- 90 CT.  
• 33 GAL- 60 CT.

**YOUR CHOICE!**

# ASSEMBLE IT YOURSELF... and SAVE!



**STUDENT DESK**

- Timberland finish.
- Measures 29" H x 36 7/8" W x 15 1/2" D
- Tough stain and scuff resistant finish.

**\$34**

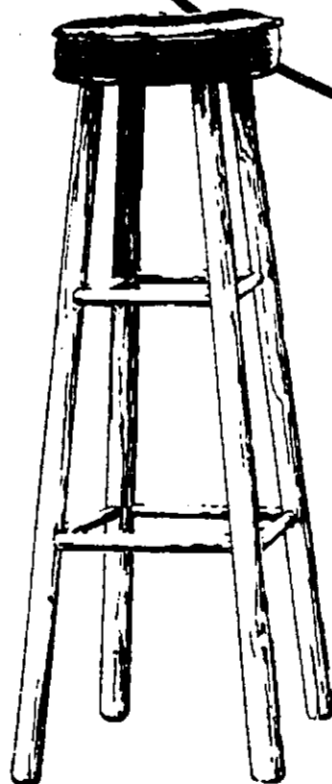

**30-INCH BAR STOOL**

- Dark wood finished legs.
- Black or Russet vinyl padded seat.

**888**  
BLACK OR RUSSET

**3-SHELF BOOKCASE**

**\$34**

- Measures 41 1/2" H x 27 5/8" W x 11 5/8" D
- Timberland finish.
- Easy to assemble.



#61319

**2-DOOR WALL UNIT**

#11819

- Beautiful dark hickory finish.
- Measures 7 1/2" H x 24 1/4" W x 9 3/8" D
- Sliding doors provide storage - additional shelf inside.

**\$49**

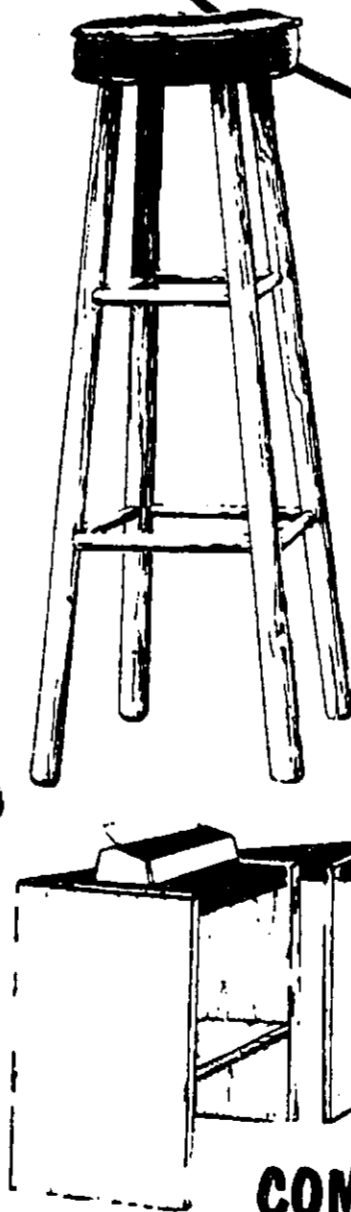

**COMPUTER STATION**

**\$99**  
• 3-piece, ready to assemble unit.  
• Includes printer stand, corner unit and desk with hutch top.  
• Oak finish.

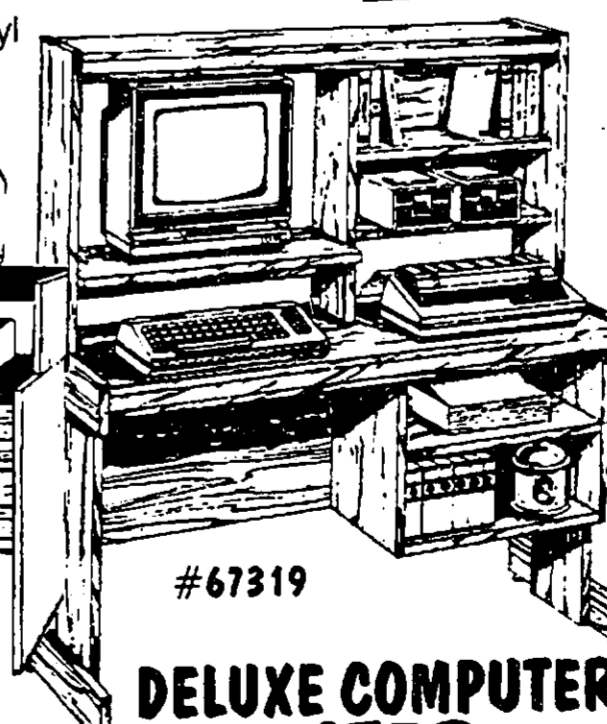

**DELUXE COMPUTER CENTER**

**\$89**  
• Adjustable shelves throughout  
• 51" H x 49" W x 23 3/8" D  
• Printer paper feed slot.

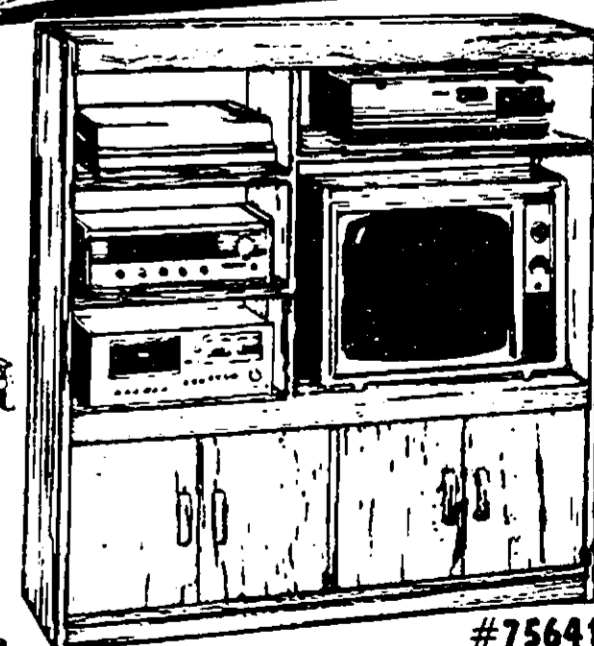

**ELECTRONICS CENTER**

**\$99**  
• Ample room for T.V., VCR tapedeck.  
• Measures 47 5/8" H x 48 7/8" W x 15 5/8" D  
• Sierra Oak finish.

# LOW WAREHOUSE PRICES!

**Coleman POWERMATE**



**500 WATT COMPRESSOR**

**\$299**

- 500 Watt surge, 400 watts rated.
- Highly portable, weighs 12½ lbs.

While quantities last.

**BLACK & DECKER**



**10-INCH DELUXE RADIAL SAW**

**\$499**

#7749

- Power plus 2 ½ HP 100% ball bearing induction motor.
- Handles big jobs around the house.

**Coleman POWERMATE**

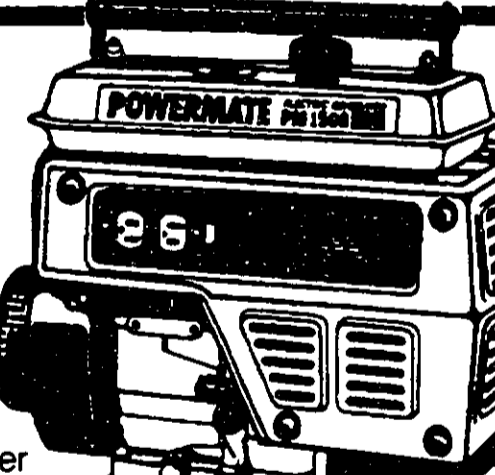

**1500 WATT COMPRESSOR**

**\$396**

- 1500 watts surge, 1200 watts rated.
- Super quiet 4 cycle engine.
- 12 volt DC battery charger with battery cables.

**10-INCH BANDSAW**



**\$97**

#BSW10

- Direct drive.
- ½ H.P. maintenance-free motor.
- Table tilts 0°-45° for beveled cut.

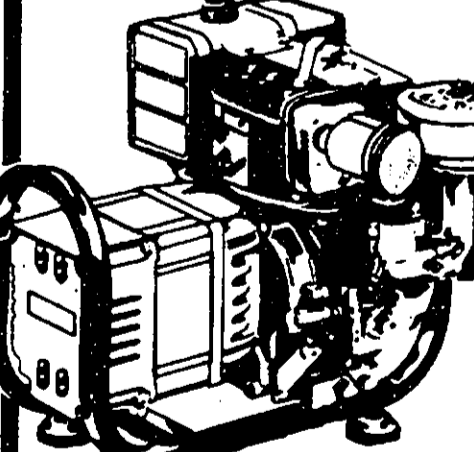

**4000 WATT COMPRESSOR**

**\$429**

- 5000 watts surge, 4000 watts rated.
- Heavy-duty Briggs and Stratton 8 HP engine.
- Two 120 and two 240 volt AC outlets.



**16-SPEED FLOOR MODEL DRILL PRESS**

**\$159**

- Floor model drill press has a ½ h.p. motor.
- ¾" drilling capacity with 12" round rotating and tilting table.

**Woods**



**100-FOOT OUTDOOR EXTENSION CORD**

OUR LOW PRICE **\$17**

LESS MFR. REBATE **-\$5**

YOUR FINAL COST AFTER REBATE **\$12**

LIMIT ONE REBATE PER HOUSEHOLD. #1671U



**6-INCH BELT FINISHING SANDER**

**\$197**

- Industrial ½ H.P. motor
- Includes heavy-duty stand.

# COMPRESSORS!

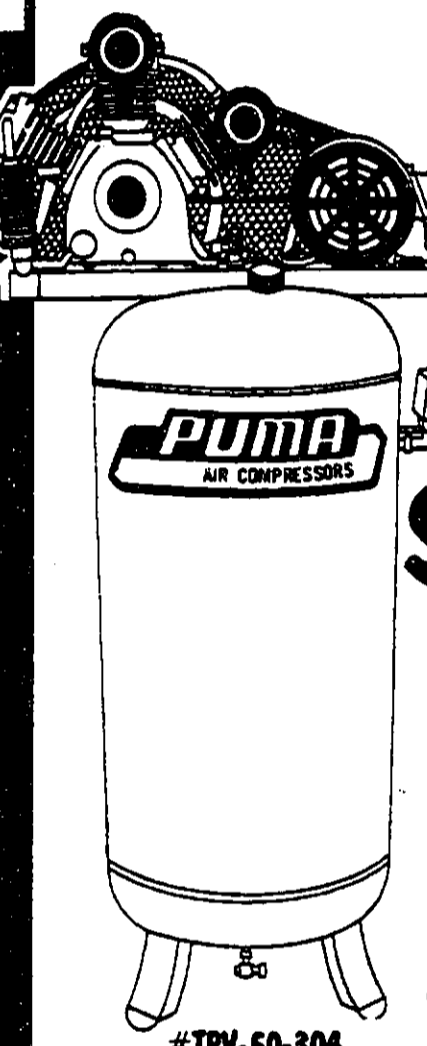

**5 HP 80 GALLON TWO STAGE AIR COMPRESSOR**

**\$844**

#TPV-50-304

- All cast iron housings and cylinders.
- Built in finned inter cooler for cooling and prevention of moisture build-up.
- Built in after cooler and buffer zone.

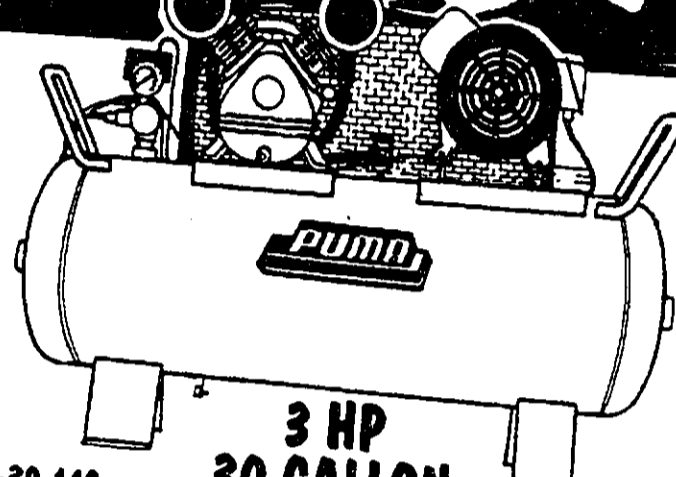

**3 HP 30 GALLON AIR COMPRESSOR**

#PPH-30-110

**\$396**

- Electric air compressor.
- Made of aluminum die cast construction with cast iron cylinder.
- Produces 10.3 CFM at 90 PSI.

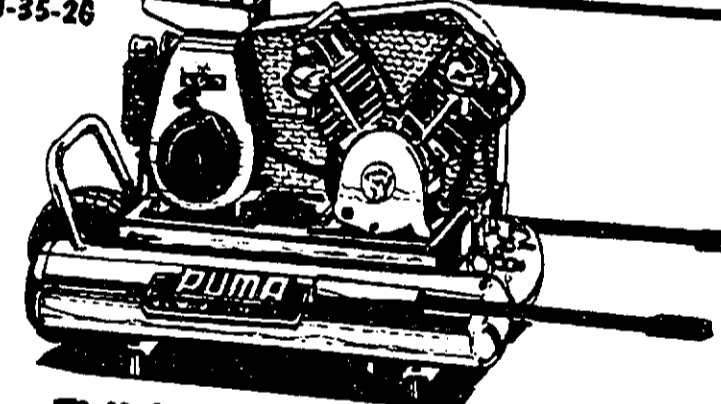

**TWIN TANK COMPRESSOR**

#PU-35-26

**\$459**

- 3.5 HP Honda engine twin cylinder, twin 16-liter tank design produces 7.9 CFM.
- Low profile, gasoline-powered.



**7-INCH VERTICAL POLISHER**

**\$39**

#PA7070

- A buffer to polish your car or truck.



**¼-INCH DIE GRINDER**

**\$19**

#PA-7030

- Heavy duty air tool.
- Maximum RPM 25,000
- Recommended air pressure-90 PSI.
- Collet size - ½".

**NO MIDDLEMAN MARKUP!**



**AIR HAMMER KIT**

#PA-7730

**\$14**

- Air hammer with four chisels.

**GREAT BUY!**



**¾-INCH AIR RATCHET WRENCH**

#PA7660

**\$17**

- Ball and needle bearing construction.



**½-INCH IMPACT WRENCH**

#PA-7630

**\$19**

- Rocking Clutch.
- Built-in speed regulator.
- Torque: 230 FT/LB.

# LOW WAREHOUSE PRICES!

**SOLD IN 250-FT. BOXES**

**12/2 NON-METALLIC GROUNDED ELECTRICAL CABLE BUILDING WIRE**

**\$26**

- For both exposed and concealed interior wiring.

14/2 NM.....	\$19
10/2 NM.....	\$50
10/3 NM.....	\$79

**LEVITON GROUND FAULT CIRCUIT INTERRUPTER**

**\$9** YOUR CHOICE WHITE - IVORY

**LEVITON QUIET SWITCHES**

**42¢** BROWN OR IVORY

- Smooth functioning.
- Quiet as a whisper.

**LEVITON GROUNDING OUTLETS**

**33¢** BROWN OR IVORY

- For easy replacement of your worn outlets.

# SAVE WHERE THE BUILDERS SAVE!

**WOODS SINGLE OUTLET SURGE SUPPRESSOR**

**784**

- Single grounded outlet with indicator light and EMI/RFI filters.

**WOODS SIX OUTLET SURGE SUPPRESSOR**

**993**

- With EMI and RFI protection.
- Protects on all three lines.

**WOODS 110-FOOT OUTDOOR EXTENSION CORD**

**993**

- Heavy-duty grounded cord.
- Use with power tools, electric lawnmowers, trimmers.

#16-3SJT

**MASON WEATHERPROOF ADJUSTABLE LAMP HOLDER**

**176**

- For 75-150W (max.) Par-38 lamps.
- Baked enamel finish.
- Porcelain socket.
- Locknut and gasket included.

ROUND LAMPHOLDER COVER .... 1.58 gray finish.

**MASON WEATHER-PROOF ROUND BOX**

**273**

- Use outdoors to add lights.
- Heavy duty die cast construction.

RECTANGULAR BOX ..... 1.67

**MASON WEATHERPROOF LIGHTING KITS WITH 2 LAMP HOLDERS**

**867**

- Includes box, cover, lampholders and accessory parts.

**Wheel CORD WHEEL**

**487**

- Holds up to 100/125 ft. of 16/3 outdoor extension cord.
- Great for rope, chain, garden hose, etc.

100-FOOT CAPACITY CORDWRAP ..... 1.12

**MASON WEATHERPROOF PHOTOELECTRIC SAFETY LIGHT**

**1083**

- Photo-electrically controlled safety light.
- Permanent mount.
- For installation with 1/2" NPT conduit.

**MASON WEATHERPROOF LANDSCAPE LIGHT WITH 3-TIER**

**1063**

- Heavy duty die cast construction with green baked enamel finish.

**WOODS OUTDOOR SPIKE LIGHT KIT**

**493**

- Garden light.
- Weatherproof.
- Non-metallic socket.

75 or 150 WATT FLOOD BULB ..... 1.99

**WOODS 6-OUTLET GFCI POWERSTRIP**

**1443**

- Six heavy duty grounded outlets.
- Rugged insulated plastic housing.

250 FT. BOX OF 12/2 UF GROUNDED BUILDING WIRE

14/2 UF WG	\$26
10/2 UF WG	\$56

**\$35**

- Suitable for outdoor use and direct burial.

**ELECTRIFYING BUYS!**

**Carlson PVC ELECTRICAL BOX**

**20¢**

- A safe, single gang work box.
- Non-metallic.
- Non-conductive.
- 18 cubic inch.

#118

**Carlson CEILING BOX**

**78¢**

- Non-metallic, non-conductive.
- 2 1/4" depth.
- For new construction.

#B520A

**12 - CIRCUIT LOAD CENTER**

**\$28**

- 125 Amperes Main Lug
- Convertible to Main Breaker
- Surface Mount

**1/2" OR 1" SINGLE POLE BREAKER**

**333**

- Branch circuit breakers consist of 15-30 Amperes and 120/240 volt AC.

**KELLER 6' FIBERGLASS STEP LADDER**

**\$79**

- Type 1A Industrial grade heavy duty.
- Non-corrosive fiberglass.
- Full 3" aluminum step deeply serrated for grip.
- Heavy duty spreader bars.

8' .....	\$109
----------	-------

# LOW WAREHOUSE PRICES!



**HEMCO PORCH FIXTURES WITH PHOTO CELL**  
YOUR CHOICE OF 2 STYLES

- Photoelectric eye turns lamp on at dusk and off at dawn automatically.
- Great for entrance, driveway, porch, patio, office etc.

**\$11 EA.**  
#PL-758J



**OUTDOOR SWIVEL PHOTO CELL LIGHT**

- Ideal for security lighting.
- 180° radius positioning; can be directed away from oncoming headlights or any other possible light reflection from nearby lighting.

**\$7**



**OUTDOOR LIGHT CONTROL**

- 2000 watt capacity.
- Direct wire-in control for outdoor applications.
- Automatic photo-eye.
- U.L. listed.

**850**

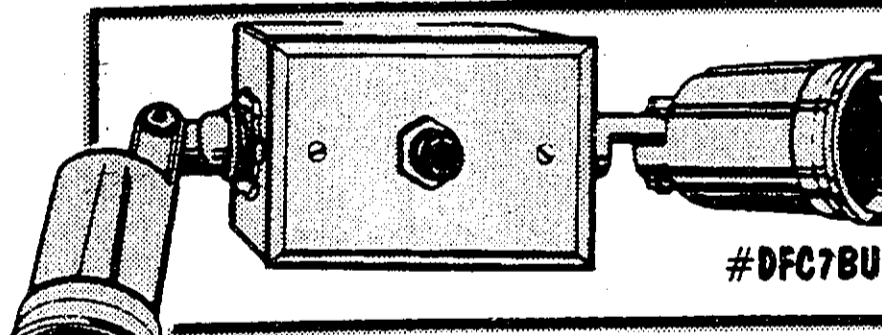

**PHOTOELECTRIC SAFETY LIGHT**

- Photo-electrically controlled safety light.
- Permanent mount.
- For installation with 1/2" NPT conduit.

**\$10**  
#DFC7BU

## THOMAS OUTDOOR LIGHTING

**PORCH LIGHT**

**396**

- Fluted glass; black rust-resistant.
- Uses one 75-watt bulb.
- 4 1/2" x 8" x 5"

**BLACK WALL LIGHT**

**\$7**

- Great for front porch, back door, garage entry, driveway, etc.

ANTIQUE BRASS.....\$8

**SOLID BRASS COACH LIGHT**

**\$10**

**BLACK CONTEMPORARY WALL LIGHT FIXTURE**

**\$12**

ANTIQUE BRASS.....\$14

**TWIN PACK SOLID BRASS LANTERNS**

**\$19**

- Solid brass wall bracket.
- Beveled smoke glass shade.

# CONTRACTOR PRICES!

## HOME-VUE FLUORESCENT LIGHTING

**2-LIGHT WRAP AROUND**  
20-WATT

**\$24**

24-INCH LONG

2-LIGHT 48-INCH .....\$29  
4-LIGHT 48-INCH .....\$49

- Home styled ceiling fixtures.
- Ideal for room remodeling.
- Several sizes available.
- Bulbs not included.

**OAK DROP DISH OR OAK GRID LIGHT**

40-WATT

**YOUR CHOICE**

**\$89**

- Solid natural oak frames.
- Durable, non-yellowing white acrylic light diffuser.
- Choice of dropped diffuser or flat diffuser with oak grid.
- Gives the effect of incandescence.
- Uses less electricity - lasts longer - gives more light.
- 4 lamp - 40 watt fixture.

LAMPS NOT INCLUDED

## HOME-VUE RECESSED LIGHTING

**MINI-ROUND OPEN REFLECTOR**

**\$8**

- Self-contained economy downlight.
- Accent lighting in any room.

150 WATT OPEN REFLECTOR .....\$18

**FLUSH OR DROP THERMALLY PROTECTED DOWNLIGHT**

**\$19**

YOUR CHOICE

- High light output with minimal glare.

**BLACK BAFFLE**

**\$19**

- Black baffle concentrates light and eliminates glare.
- Creates mood and atmosphere while providing efficient lighting.

BLACK BAFFLE FOR INSULATED CEILINGS.....\$22

**100 WATT SQUARE RECESSED**

**\$21**

150 WATT ALBALITE SQUARE .....\$27

**WALL WASH**

**\$22**

- Directs light where desired.

**EYEBALL**

**\$26**

- Directional lighting for walls, pictures, or corners.
- Uses one 75 watt reflector bulb.

INSULATED EYEBALL FOR INSULATED CEILINGS .....\$27

## GREAT BUY ON LIGHT BULBS

**4-PACK SOFT WHITE LIGHT BULBS**

**167**

• 40, 60, 75 or 100 watt.

**48-INCH SOFT WHITE MISER™ FLUORESCENT**

**196**

2-PACK MISER™ PAR OUTDOOR FLOODLIGHTS

**649**

• Get usable light of higher watt floods for fewer watts of electricity.

4.49 AFTER \$2 MFR. REBATE

YOUR CHOICE! \$3

MISER FLOOD & SPOTLIGHT

• For track or recessed lighting.

# CEILING FANS



**INSTALL IT!  
CEILING FANS**  
ON STANDARD  
LIGHT FIXTURE  
REPLACEMENTS  
**\$40**  
Labor  
Only!  
FOR NORMAL  
INSTALLATION  
and it's **GUARANTEED!**

**42-IN PARK AVENUE**  
#DC42  
**\$30**

- 4 stenciled wood blades.
- Built in 3-speed control.
- Reversible motor.
- Dual mount hanging system.
- Light kit adaptable.

AVAILABLE IN ANTIQUE OR POLISHED BRASS AND WHITE

**36-INCH WHITE OR BROWN**  
#V36R-4W  
**\$15**

- 3-speed pull chain operation.
- 4 wood blades.
- Reversible motor.

**52-INCH PARK AVENUE..... \$34**  
#DC52VB  
**\$46**

- 5 Cane imported wood blades.
- Built in 3 speed control
- Dual mount hanging system.

AVAILABLE IN ANTIQUE OR POLISHED BRASS AND WHITE

**52-INCH EMPEROR**  
#T52MA  
**\$37**

- 4 cane inserted wood blades.
- Completed with schoolhouse lite kit.

**52-INCH CRYSTAL AIR FAN**  
#CR-52-BL  
**\$79**

- Crystal diamond-cut glass design.

**52-INCH OLD VIC**  
#A52M102  
**\$39**

- Built in three speed control.
- Reversible motor.
- Lite-kit adaptable.
- 4 stenciled wood blades.

AVAILABLE IN ANTIQUE OR POLISHED BRASS AND WHITE

**52-INCH BIARRITZ**  
#23025  
**\$79**

- Designed exclusively for Builders Square by Hunter, a name you can trust.

## LIGHT KITS IN ANTIQUE OR POLISHED BRASS

**4-LIGHT TULIP GLASS**  
**\$11**

- With all mounting hardware.

**3-LIGHT RIBBED AMBER GLASS**  
**\$12**

- 3 lite ribbed champagne glass.

**4 LAMP FROSTED**  
**\$16**

- Antique brass or bright glass finish.

**SINGLE**  
**\$17**

- Smoked beveled glass.

**5-LIGHT BEVELED**  
**\$29**

- Beautiful smoked amber glass.

# BATHROOM FIXTURES TO FIT ANY BUDGET!

## Artesian TOILETS

**WHITE ATLANTIS WATER-SAVER**  
#C4401 C4305  
**\$59**

- Operates efficiently on only 3½ gallons per flush.
- Round front bowl and straight front pedestal base for easy cleaning.
- Toilet seat extra.

**WHITE ANTIGUA**  
#4385 4485  
**\$144**

- Sleek, elongated design at affordable price.
- Installed tank liner; efficient, quiet action.
- Seat extra.

COLORS ..... \$179

**WHITE ECONOMY TOILET**  
#R01018  
**\$30**

- China economy toilet.
- Round lip, water saver with reverse trap.
- Hem may vary in appearance.
- Traditional styling.
- Seat extra.

## Artesian BATH TUBS

**ECONOMIZER™**  
#A9820 A9821  
**\$77**

- Fits standard five foot pocket.
- Full depth for bathing comfort.
- Textured non-slip surface.

**WHITE VERSA TUB™**  
#A9820 A9821  
**\$109**

- 60"x30"x16¼"
- Made of thick durable PVC.

COLORS .... \$124

**ORIGINAL BUBBLE BATH TUB**  
#A9820 A9821  
**\$444**

- Four adjustable posiflow jets.
- U.L. listed pump.

ALMOND.....\$477

## KINKEAD™ ENCLOSURES

**KINKEAD™ SHOWERGLIDE™ PLAIN BY-PASS BATH**  
#1100 SERIES  
**\$33**

- Smart decorator styling.
- Tempered safety glass in rich textured pattern.

SWAN DESIGN....\$39

**KINKEAD™ SHOWERGLIDE™ SILVER MIRROR SLIDING TUB**  
#1100 SERIES  
**\$99**

- Tempered safety glass in textured door.

GOLD.....\$114

**KINKEAD™ SHOWERGLIDE™ SILVER TRI-PANEL MIRROR DOOR**  
#1700  
**\$144**

- Mirror center panel adds spacious look.
- Opens wide for convenience.

GOLD.....\$157

# LOW WAREHOUSE PRICES!

**Accent** #063-896  
#06389B  
POLISHED OR ANTIQUE BRASS

**YOUR CHOICE**

#84421

**MOEN**

**Accent LAVATORY FAUCET W/ POP-UP DRAIN OR TWO HANDLE W/ POP-UP**

**\$27**

**ACCENT**  
• Washerless for long, trouble-free operation.

**MOEN**  
• Chrome finish, washerless faucet.

ANT. BRASS.....\$49  
POL. BRASS.....\$54

**AquaStream** #84004

**SINGLE CONTROL LAVATORY FAUCET**

**\$18**

**GREAT BUY!**

- Pop-up drain included.
- Washerless and non-metallic.
- 5 year limited warranty.
- Fast, easy installation.

## SOLID BRASS DECORATOR FAUCETS

**MOEN**

**WITH POP-UP ASSEMBLY**

**SINGLE HANDLE LAVATORY FAUCET**

**\$36**

- A quality single handle washerless lavatory faucet.
- Water/energy saving aerators.

#84521

**ANTIQUE BRASS.....\$64**  
**POLISHED BRASS.....\$69**

**MOEN** 10 YEAR LIMITED WARRANTY

**WING HANDLE LAVATORY FAUCET**

**\$39** CHROME

- Complete with clear acrylic and wood handle inserts.
- Pop-up drain included.

#84425

**POLISHED BRASS #84926.....\$69**

**MOEN**

**WIDE SPREAD OR**

**\$66**

**MOEN WIDE SPREAD**

- Chrome finish.
- Washerless design.
- 10-year limited warranty.

#84910

**AMERICAN BATH**

- Solid brass construction.
- Washerless design.
- Porcelain lever handles.

#206-L-PB

**The Atlanta** #341-L

**POLISHED BRASS LAVATORY FAUCET**

**"THE ATLANTA" \$88**

- Solid brass.
- Washerless design.
- Exclusive Marine™ protective finish.
- 5-year limited warranty.

**WIDE FAUCET.....\$177**

**The New Yorker** #349-L-PC/PB

**LAVATORY FAUCET**

**"THE NEW YORKER" \$99**

- Solid brass.
- Contemporary polished brass and chrome finish.
- Exclusive Marine™ protective finish.
- 5-year limited warranty.

**CHROME/BRASS WIDE SPREAD.....\$188**

# DAY IN...DAY OUT!

## QUALITY KITCHEN FAUCETS

**Touch Control MOEN**

**NEW**

**SINGLE-HANDLE WITH EASY HOOK-UP**

**\$29**

- Washerless.
- 10-year limited warranty.

#87403/05

**WING HANDLE**

**\$37**

- Includes clear acrylic & wood handle inserts.
- Washerless design.
- 10-year limited warranty.

**WITH SPRAY \$47**

#87413/15

**NEW**

**3-IN-1**

**\$66**

- Includes hose spray - soap/liquid dispenser.
- Washerless.
- 15-year limited warranty.

#87501A

#87535

**Touch Control MOEN SHOWER FIXTURES**

**SINGLE HANDLE TUB & SHOWER COMBINATION**

**\$39**

- Tub and shower combination with diverter tub spout, showerhead, arm and flange.

#82519

**ANTIQUE BRASS '88**  
**POLISHED BRASS '94**

**AquaStream**

**TWO-HANDLE**

**888** 5 YEAR LIMITED WARRANTY

- Washerless-non metal.

**WITH SPRAY 13.74**

**Touch Control MOEN**

**TWO-HANDLE**

**\$24**

- Washerless.
- 10-year limited warranty.

#87417

#87401

**WITH SPRAY \$34**

**MOEN**

**POSI-TEMP™ TUB & SHOWER CONTROL**

**\$55**

- Stops shower shock.
- Balances hot and cold water pressure.

#82339

**TWO-HANDLE BAR SINK FAUCET**

**\$35**

- Washerless.
- 10-year limited warranty.
- Water/energy saving aerator.

#87916

**MOEN LIQUID DISPENSER**

**\$19**

- Keeps liquid soap or hand lotion within easy reach.
- Top lifts off for easy refill.
- Installs in minutes.

#3910A

Chrome-Plated Solid Brass

Extra-Large Reservoir for Soap or Lotion

# American Woodmark Cabinets®

**LOW WAREHOUSE PRICES!**



**60% OFF**  
MFG'S. SUGGESTED LIST PRICE

- MODEL #'S
- W2130
  - W3018
  - W1430
  - VAL48
  - W3030
  - CW2430
  - W2730
  - W1830
  - W3315
  - B21
  - DB18
  - TSF36
  - CAR36
  - B33

NOW ONLY...

## CAMEO

13'6" x 8'9" L-SHAPED KITCHEN

• Kitchen includes: 8 wall cabinets, 3 base cabinets, corner carousel, sink front\* and valance.

**1139<sup>60</sup>**

MFG'S. SUGGESTED LIST PRICE ..... \$2849

BUILDERS SQUARE OFFERS NEXT WEEK delivery on more than 10 American Woodmark contemporary and traditional styles. Cabinets are available in light and mid-tone oak finishes.

ALSO AVAILABLE IN THESE STYLES:

BROOK FIELD	POTOMAC	MISSION	ELITE	SHEFFIELD SQUARE	SHEFFIELD CATHEDRAL
976 <sup>40</sup>	1360 <sup>80</sup>	1424 <sup>40</sup>	1605 <sup>60</sup>	1602 <sup>20</sup>	\$1712

### CHOOSE FROM MANY CABINET STYLES

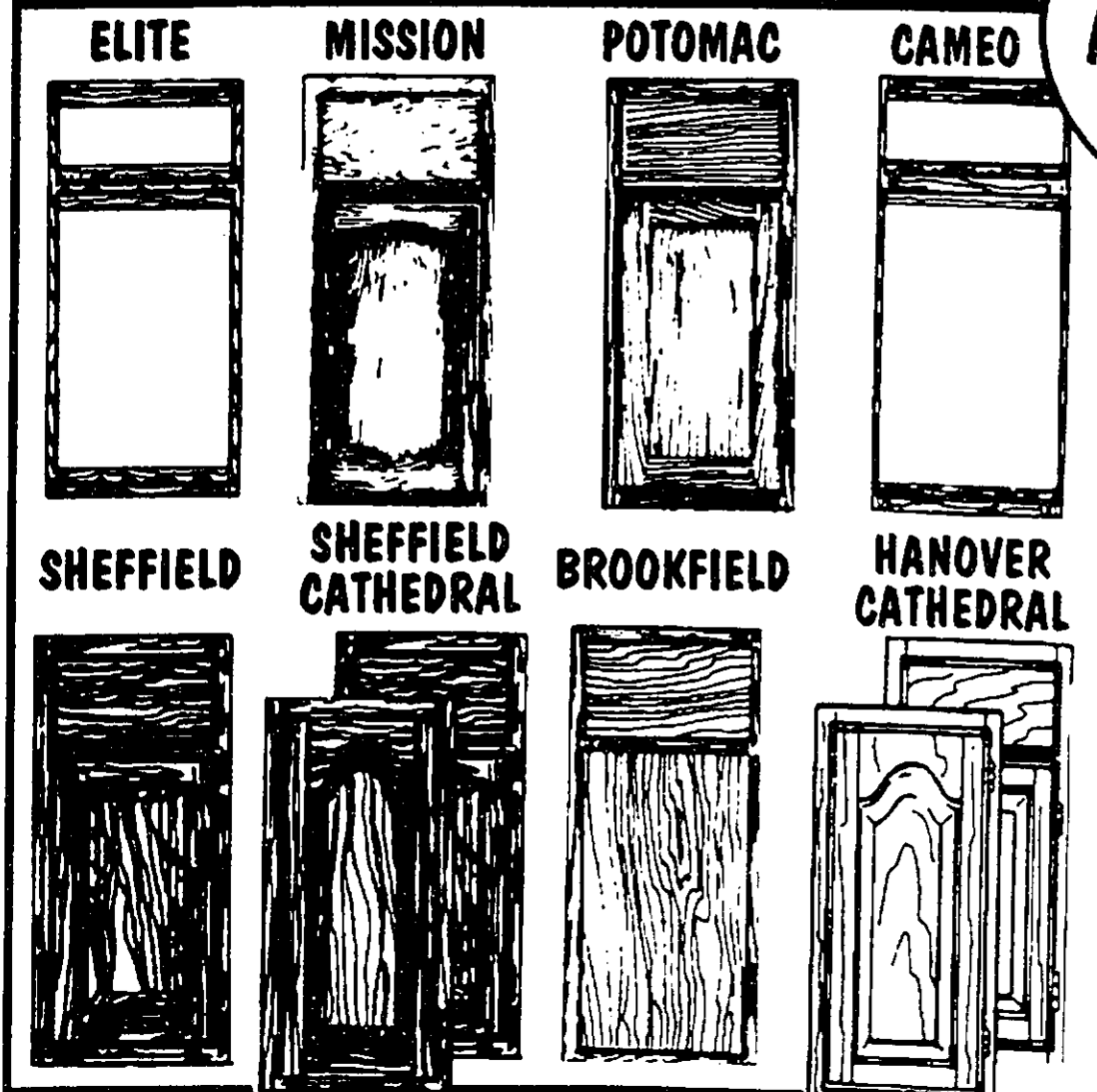

SAVE AN ADDITIONAL **15% OFF** ALL KITCHEN CABINET INSTALLATION SEE PG. 26B FOR DETAILS



**YOUR CHOICE!**  
BUTCHER BLOCK, GOURMET OAK, ALMOND WHITE, PAPERUS

POST FORMED COUNTERTOPS 3<sup>25</sup> PER LIN. FT. ASSORTED DECORATIVE STYLES

6'	19.50	10'	32.50
8'	\$26	12'	\$39



# American Woodmark Corporation®

## POTOMAC

13'6" x 8'9" L-SHAPED KITCHEN\*

• Kitchen includes: oak doors and drawer fronts, solid oak front frame construction.

**60% OFF**

MANUFACTURER'S SUGGESTED LIST PRICE

**1369<sup>60</sup>**

MFR'S. LIST PRICE \$3424

\*SINK, COUNTERTOPS AND APPLIANCES NOT INCLUDED

ALSO AVAILABLE IN THESE STYLES:

BROOK FIELD	CAMEO	MISSION	ELITE	SHEFFIELD SQUARE	SHEFFIELD CATHEDRAL
991 <sup>20</sup>	1148 <sup>80</sup>	1474 <sup>80</sup>	1566 <sup>40</sup>	\$1612	1714 <sup>40</sup>

# American Woodmark Corporation®

\*MFR'S SUGGESTED PRICES ARE FOR COMPARISON ONLY. YOU WILL ALWAYS FIND DISCOUNTED PRICES AT BUILDERS SQUARE.

## MISSION

13'6" x 8'9" L-SHAPED KITCHEN\*

• Kitchen includes: 6 wall cabinets, 4 base cabinets, utility cabinet, filler strip and valance.

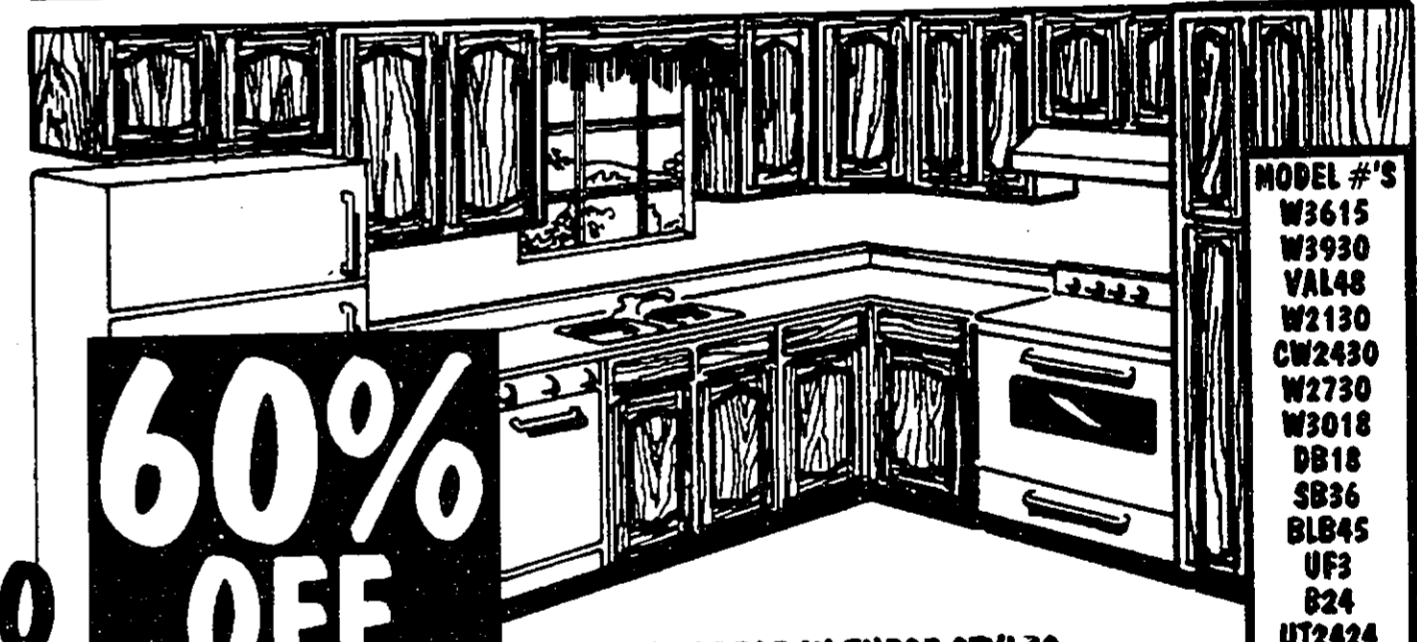

**60% OFF**

MANUFACTURER'S SUGGESTED LIST PRICE

**1475<sup>60</sup>**

MFR'S. SUGGESTED LISTED PRICE ..... \$3689

ALSO AVAILABLE IN THESE STYLES:

BROOK FIELD	CAMEO	POTOMAC	ELITE	SHEFFIELD SQUARE	SHEFFIELD CATHEDRAL
986 <sup>40</sup>	1149 <sup>20</sup>	1373 <sup>20</sup>	\$1568	1614 <sup>40</sup>	1736 <sup>80</sup>

## QUALITY DOORS REPLACEMENT CABINET DOORS

**60% OFF** MFR'S. SUG. LIST PRICE

• Special ordered to your specifications.  
• Cabinet doors come in 12 designs and 4 hardwoods.  
• Available prefinished or ready-to-finish.



## allison Cabinet Caddies™ STORAGE SYSTEM



A. 11 1/2" UNDER SINK RACK  
B. 14" ROLL-OUT TRAY ..... **12<sup>50</sup>**  
ALSO AVAILABLE:  
14 1/2" UNDERSINK RACK ..... **\$16**  
20" ROLL-OUT TRAY ..... **\$16**  
C. ROLL-OUT TRASH CONTAINER ..... **14<sup>87</sup>**

## allison Cabinet Caddies™

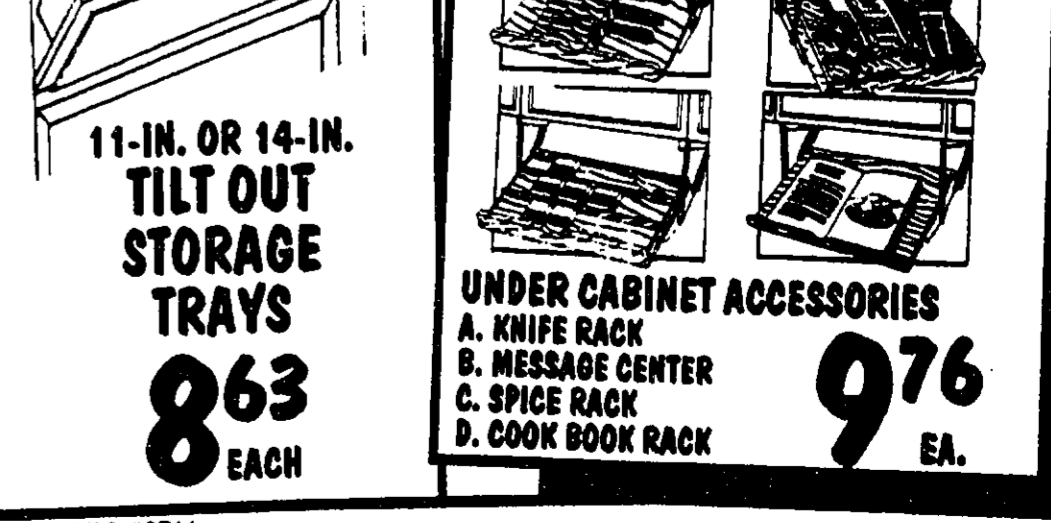

11-IN. OR 14-IN. TILT OUT STORAGE TRAYS **8<sup>63</sup>** EACH

UNDER CABINET ACCESSORIES  
A. KNIFE RACK  
B. MESSAGE CENTER  
C. SPICE RACK  
D. COOK BOOK RACK **9<sup>76</sup>** EA.

# LOW WAREHOUSE PRICES!

## 12-FOOT WIDE CARPET

### WALL STREET

**392** SQ. YD.  
5.22 LF.

- 100% Olefin level loop cushion back.
- Stain resistant, easy care.
- Easy to install.

### STATE STREET

**487** SQ. YD.  
6.50 LF.

- Attached cushion back.
- Easy to install.

### BROADWAY

**556** SQ. YD.  
7.42 LF.

- 100% continuous filament nylon.
- Attached cushion back.
- 5-year limited Mfr. warranty.

### FIFTH AVENUE

**617** SQ. YD.  
8.23 LF.

- 100% continuous filament nylon.
- Attached cushion back.
- 5-year limited manufacturer's warranty.

CAMELOT PRIME FOAM PAD ..... **98¢** LF.

WE RING UP SHEET VINYL AND CARPETING BY THE LINEAR FOOT. OUR ADS ALSO SHOW SQUARE YARD PRICING FOR YOUR CONVENIENCE.

BROWN, SPRING GREEN, SMOKE BLUE, BLACK

#4612

### 27-INCH CARPET RUNNER

**194** LF.

- Protects carpets from mud, dirt, and grease.
- Available in black, brown, spring green, and smoke blue.

#SR1/2

**42¢** LF.

### 27-INCH VINYL RUNNER

- Protect your carpets from mud, dirt, grease.
- Available in clear or gold.

## ORIENTAL RUGS \$9

- Choose from four colors per size.

20" x 42" ..... \$9  
32" x 52" ..... \$19  
67" x 99" ..... \$69  
99" x 138" ..... \$119

# GUARANTEED LOWEST PRICES

## 12"x12" COMMERCIAL DURAVINYL® FLOOR TILE

**35¢** EACH

- Durable. • Economical.



ALL FLOOR TILE SOLD IN FULL CARTONS ONLY.

AMTICO

<b>CAREFREE® NO-WAX</b> FINGER BLOCK BRIKETTE <b>38¢</b> EA. <b>43¢</b> EA.	<b>FLORAL PARK DESIGNER CAREFREE®</b> <b>61¢</b> EACH	<b>RALEIGH ADVANTAGE™</b> <b>76¢</b> EACH	<b>ROCK GARDEN MAJESTIC™</b> <b>94¢</b> EACH
---	--	--	---

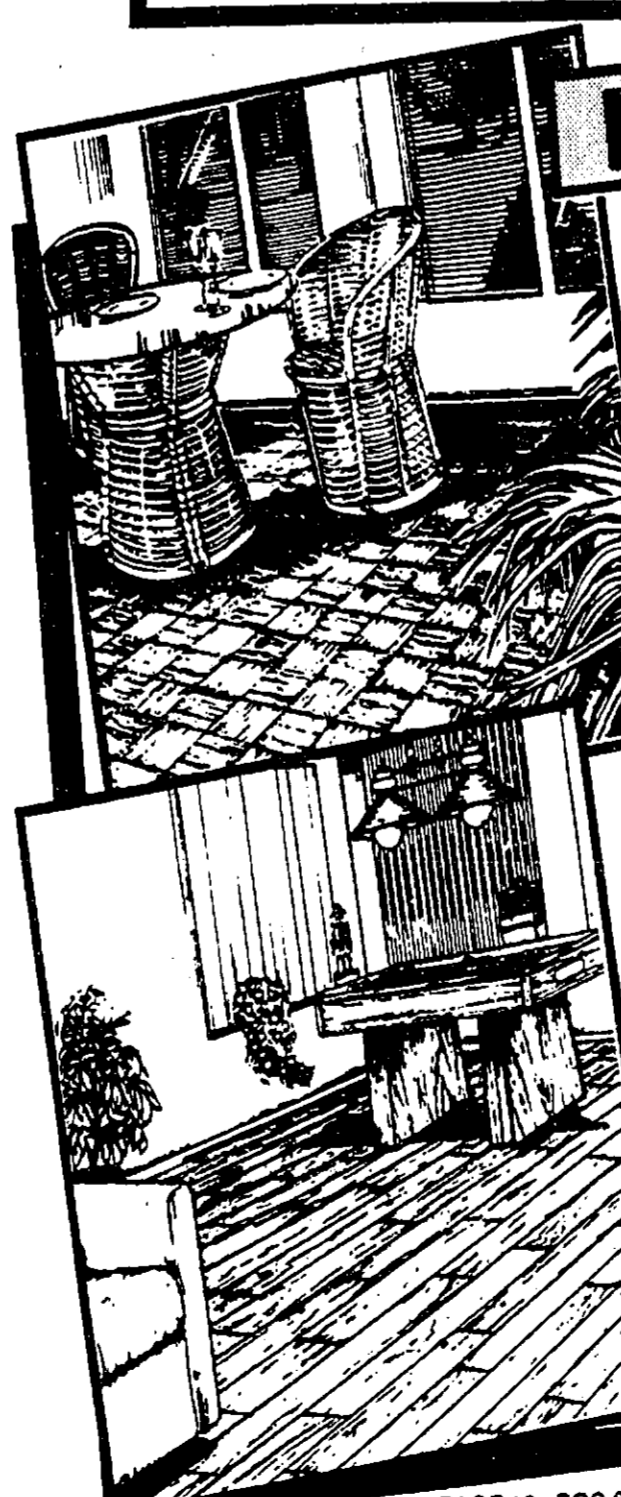

## Bruce OAK HARDWOOD FLOORING

12"x12" PARQUET  
**234** EA.

3"x48" PLANKING  
**292** EA.

- Dura-finish - easy care, easy clean.
- Tongue and groove for easy installation.
- All necessary moulding and reducing strips available.

CHOOSE FROM DESERT OR CHESTNUT

SOLD IN FULL CTNS. OF 40-PCS.



**EVERBOND ADHESIVE \$16**

- Pliable solvent base.
- Average coverage of 45-50 square feet.

6"x6" OAK PARQUET  
**45¢** EACH  
CARTON \$18

- Solid oak parquet.
- No-wax Dura-luster™ Urethane finish.
- Easy to install.



**HEAVY DUTY TROWEL #N-1 233**



# Monarch QUALITY MIRRORS

14 x 54-INCH  
BRASS FRAMED  
OVAL MIRROR  
**\$18**

23 x 27-INCH  
RECTANGULAR  
LIGHT OAK  
FRAMED  
BEVELED  
MIRROR  
**\$28**

24x30.....	17.66
24x36.....	19.58
30x36.....	22.47
36x36.....	26.97
36x48.....	39.66

26" x 28" ... \$19  
17" x 57" ... \$31

20x60-INCH  
MIRROR ARCH  
**\$28**

24x68..... \$31

19 x 27-INCH  
OAK  
FRAMED  
OCTAGON  
MIRROR  
**28<sup>82</sup>**

14 x 50-INCH  
WALNUT  
TONE  
DOOR  
MIRROR  
**8<sup>97</sup>**

- Walnut tone woodgrain frame.
- For head-to-toe grooming.

24x24  
PLAIN  
MIRROR  
TILE  
**4<sup>97</sup>**  
PKG.

6-12"X12"  
TILES PER PKG.

# LOW PRICE HOUSE

**40% OFF**  
OUR REGULAR PRICE  
SHUTTER KITS

- Completely assembled.
- Ready to install.
- Kit contains: shutter panels, hardware, 2 hanging strips and 2 knobs.
- Prefinished or unfinished.

**Flair-Fold**

**60% OFF**  
OUR REGULAR PRICE

BUILDERS SQUARE  
1" ALUMINUM  
1" WOOD AND  
1/2" PVC  
MINI  
BLINDS

- Decorate on a budget!
- Wand tilt control.
- All necessary hardware included.

**50% OFF**  
OUR REGULAR PRICE  
BUILDERS SQUARE  
VERTICAL  
BLINDS

- Easy to care, easy to clean blinds.
- Provides privacy.

# LOW WAREHOUSE PRICES!

6-PIECE  
COMBINATION  
WRENCH SET

**592**  
#02210

- Chrome vanadium steel.
- Fully hardened.
- Precision machined-high torque performance.
- Includes 3/8, 7/16, 1/2, 9/16, 5/8, 11/16 wrenches plus storage clamps.

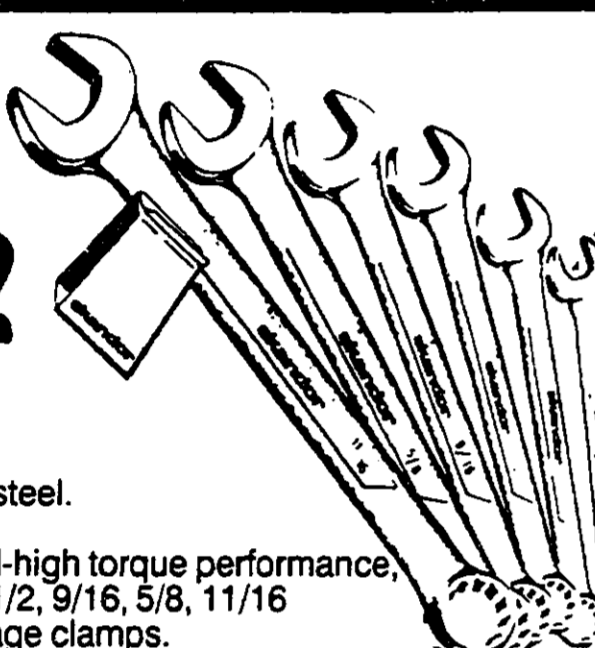

16 OZ.  
STEEL  
CLAW HAMMER

**296**  
#21030

- Drop forged, high carbon steel.
- Oval, hardened steel shaft won't bend.
- Rubber, Vinyl grip absorbs shock exceeds U.S. Federal specifications.

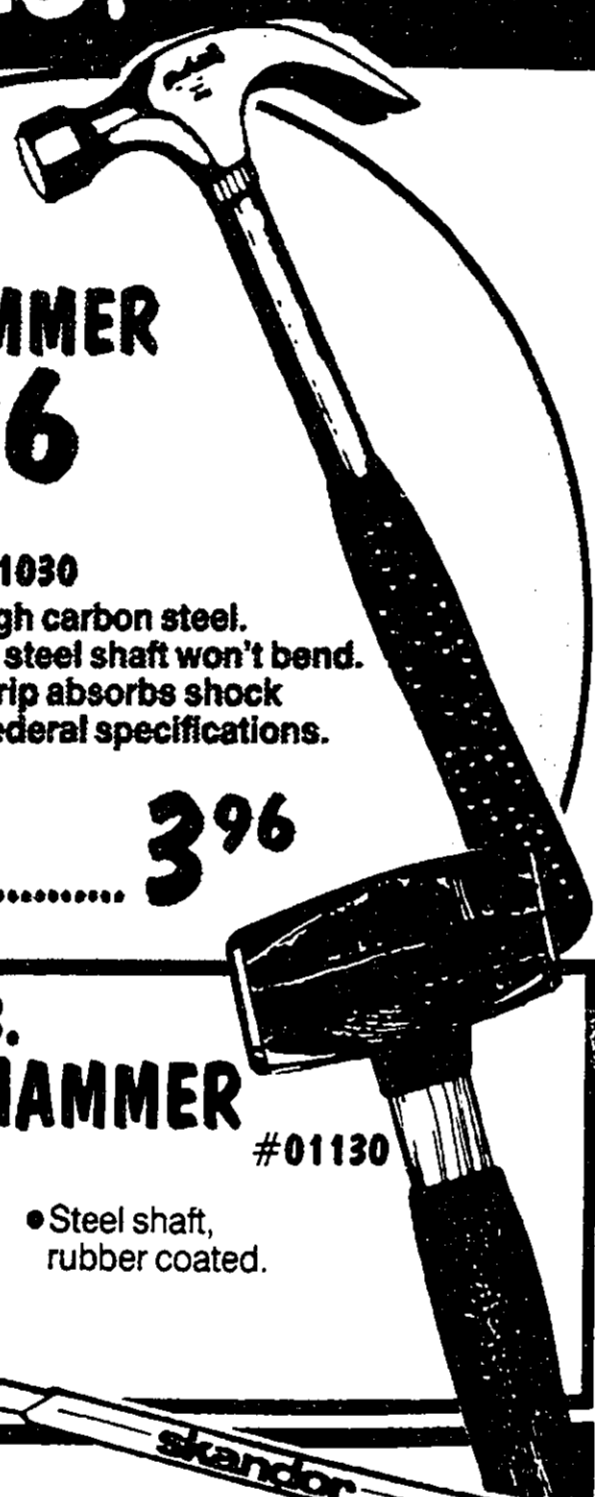

16 OZ.  
HARDWOOD ..... **396**  
#21040

4 LB.  
DRILLING HAMMER

**596**  
#01130

- Steel shaft, rubber coated.

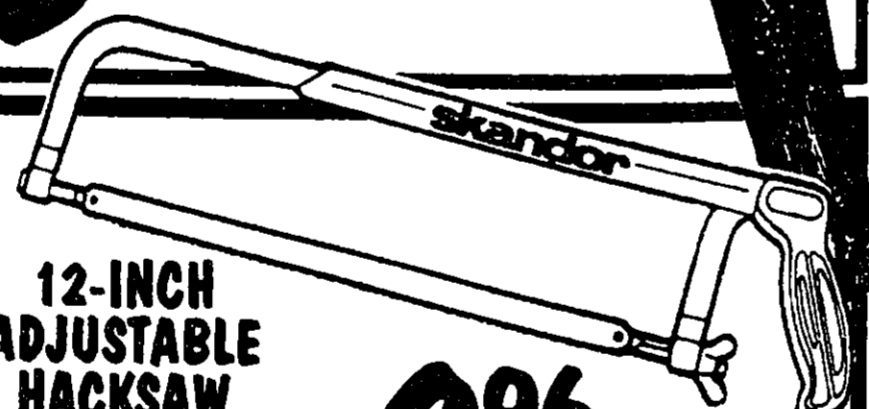

12-INCH  
ADJUSTABLE  
HACKSAW

- Adjusts to 3 blade sizes & 4 blade positions.
- 2 3/4" depth cut.
- Strong steel frame.

**296**  
#5100

HEAVY DUTY  
STAPLE GUN

**796**  
#07030

- Variable power control.
- All steel construction.
- Safety handle lock.

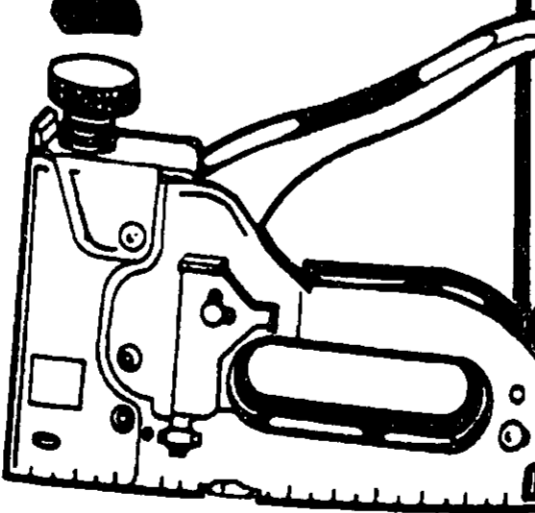

12-INCH  
BOLT CUTTER

**650**  
#9020

- Vanadium steel blades.
- Special hardened cutting edge.
- Precision adjusting screws.

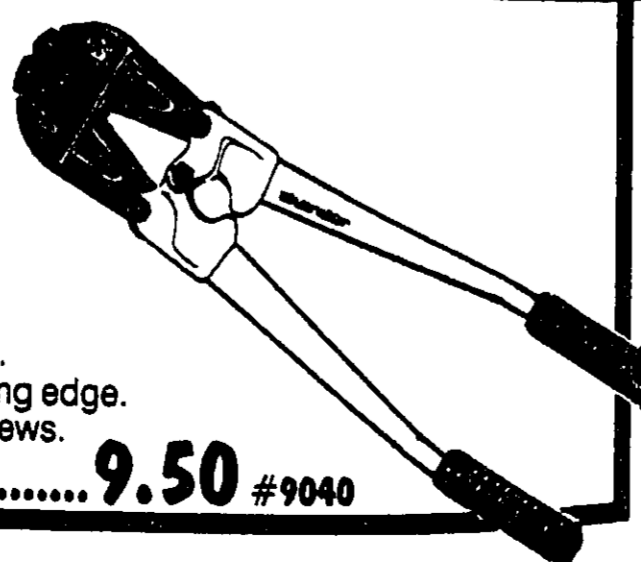

18-INCH CUTTER..... **9.50** #9040

10-INCH  
PIPE  
WRENCH

- Drop forged.
- Replaceable jaws.

**296**  
#02810

ADJUSTABLE  
WRENCH

**566**  
#02050

- Chrome-vanadium steel.
- Fully hardened.
- Triple chrome plated.

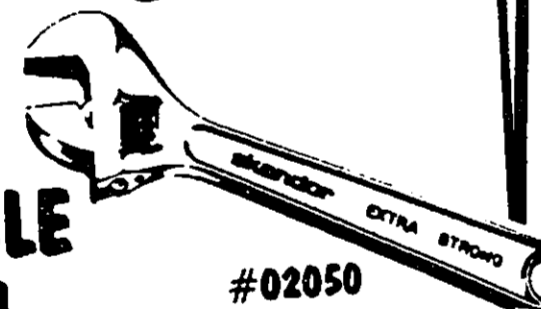

16-INCH  
PRY BAR

**296**  
#1200

- Claw and chisel machined.

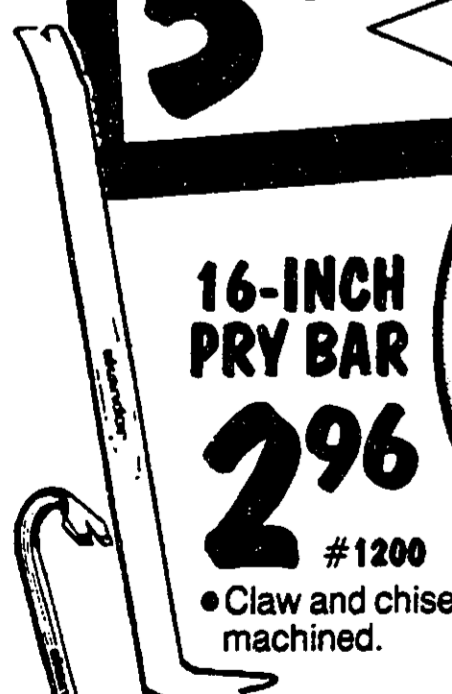

UTILITY  
KNIFE

**167**  
#6000

- Spare blades stored inside.
- Quality steel blade locks firmly in position.



24-INCH  
WRECKING  
BAR

**364**  
#1460

- Drop forged medium carbon steel.



5-INCH  
C-CLAMP

**296**  
#10200

- Drop forged high carbon steel



# COMPARE OUR PRICES TO WHOLESALE!

USG

2'x4'  
CEILING  
TILE

STONEHURST #380

**21¢**  
SQ. FT.

64 SQ. FT.  
CARTON ... **1344**

2'x4' PANELS

SOLD IN  
64 SQ. FT.  
CARTONS

SQ. FT.  
PRICE

CREVICE #137 .....	<b>24¢</b>
FLEET STREET #290 .....	<b>26¢</b>
5TH AVENUE #280 .....	<b>29¢</b>
FIRECODE #220 .....	<b>34¢</b>

2'x2' PANELS

SOLD IN 64 SQ. FT. CARTON

FLEET  
STREET  
#230

**40¢**  
SQ. FT.

SOLD IN 48 SQ. FT. CARTON

SAVILLE  
ROW  
#550 .....

**54¢**  
SQ. FT.

CHEYENNE  
#156 .....

**87¢**  
SQ. FT.

SUSPENDED CEILING GRIDS  
AVAILABLE IN BLACK OR WHITE

2 BULB  
GRID LIGHT

**\$15**

4 BULB  
#95-4411) **\$24**

- 2 Fluorescent bulbs. 40 watt.
- Some assembly required.
- Lamps not included.

2 BULB  
RECESSED  
CEILING FIXTURE

**\$29**

4 BULB  
#3333) **\$39**

- For kitchens, party rooms, bathrooms, offices, etc.
- Recesses into suspended ceilings.

YOUR CHOICE  
PRISMATIC OR  
CRACKED ICE  
AVAILABLE IN  
CLEAR OR  
WHITE

2'x4'  
LIGHTING  
PANELS

**218**  
EACH

EGG CRATE **5.98**

# LOW WAREHOUSE PRICES!

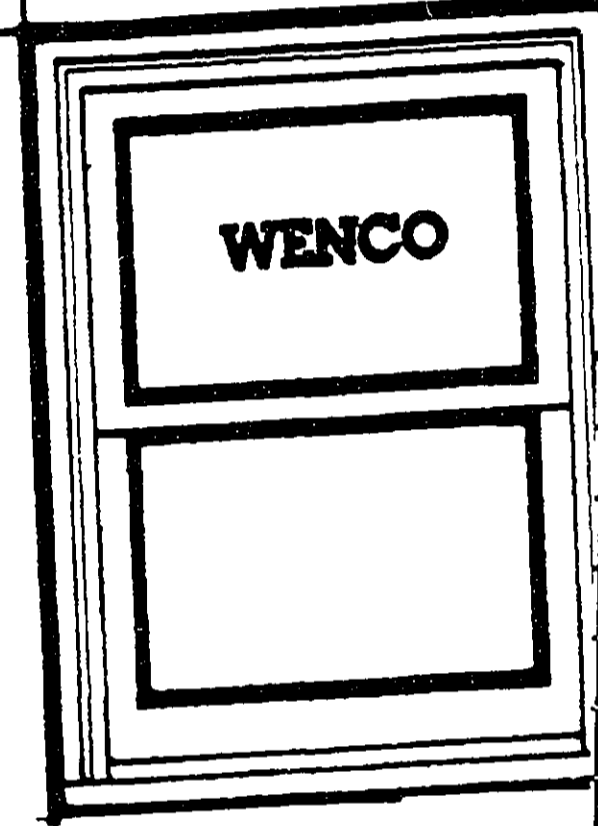
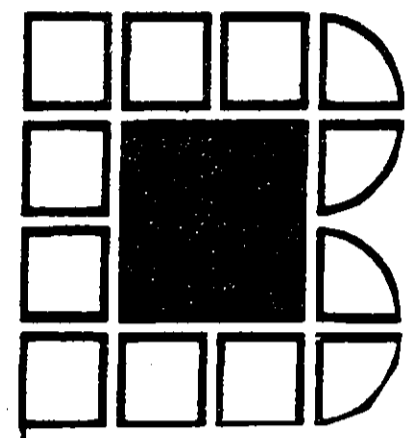

**STANDARD DOUBLE HUNG WOOD WINDOW**

SIZE	PRICE
20x16	\$49
24x16	\$53
28x16	\$55
24x20	\$58
32x16	\$59
28x20	\$59
24x24	\$63
32x20	\$65
28x24	\$65
32x24	\$69

- All wood construction.
- No exposed finger joints.
- Water repellent treated.
- Top quality primed exterior.

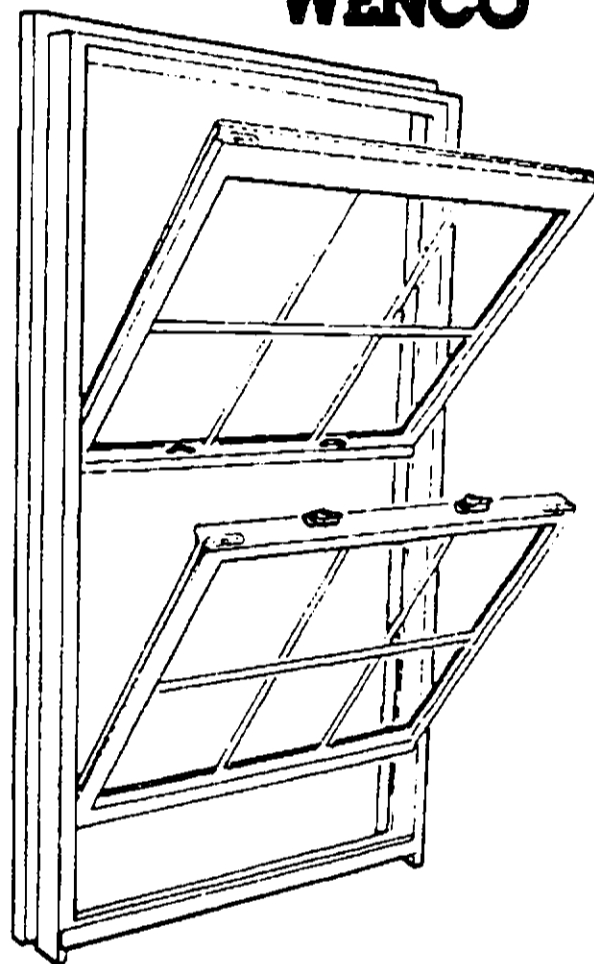

**WENCO DOUBLE HUNG PREMIUM INSULATED TILT WINDOW**

SIZE	PRICE
20x16	\$105
24x16	\$111
24x20	\$119
24x24	\$128
28x16	\$115
28x20	\$125
28x24	\$136
32x16	\$122
32x20	\$133
32x24	\$143

- Sash removal is easy and quick.
- Exterior surfaces are white clad aluminum.
- Adjustment is made easy with Jump Jack Adjusters.
- Spring loaded sash latches.

## SKYLIGHTS

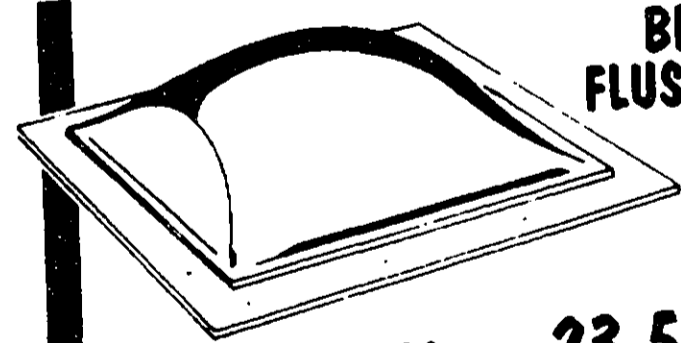

**BRONZE FLUSH MOUNT**

- Flush mount, self flashing.
- Provides natural light to interior areas of home.
- Easy insulation.

22x22..... **23.53** 22x46..... **56.25**



**DOUBLE DOME THERMALLY ENGINEERED CURB MOUNT**

- Thermally broken to protect against condensation.
- Provides natural light to interior areas of home.
- Reduces electrical lighting requirements.

24x48..... **\$88**

CLEAR SKYLIGHTS WHILE QUANTITIES LAST. SORRY, NO RAINCHECKS.

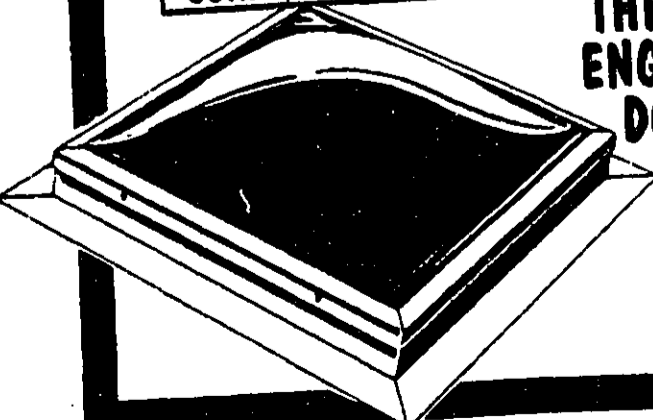

**SELF FLASHING THERMALLY ENGINEERED DOUBLE DOME**

- Passive solar collector for free light & warmth.
- Perfect for flat or pitched roofs.
- 5 year mfr. warranty.

24x48..... **\$117**

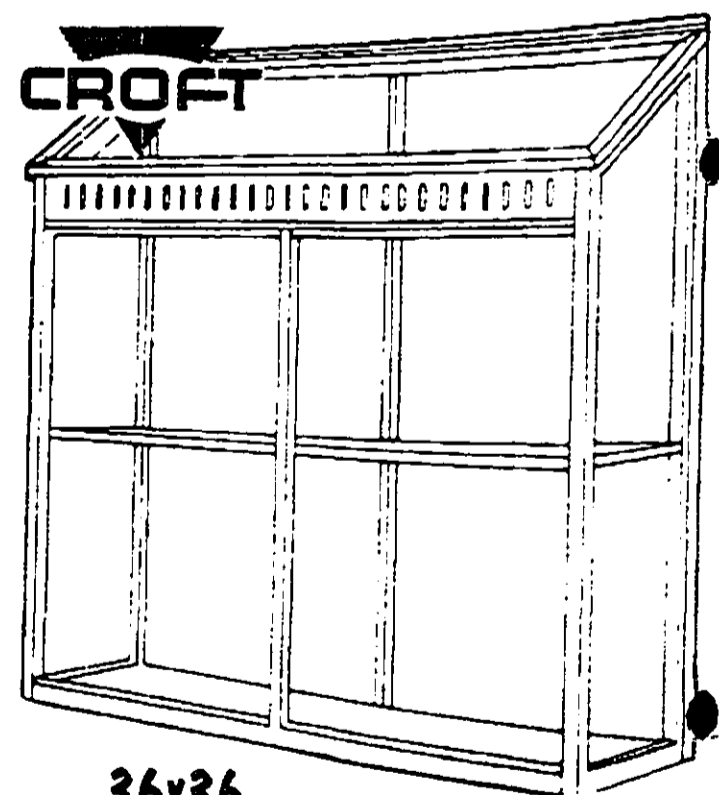

**CROFT 36x36 WHITE INSULATED GARDEN WINDOW**

36x48	\$226
48x36	\$212
48x48	\$238

- A perfect environment for plants.
- Adds charm to any home.
- Adjustable glass shelf.

# QUALITY ENTRY DOORS

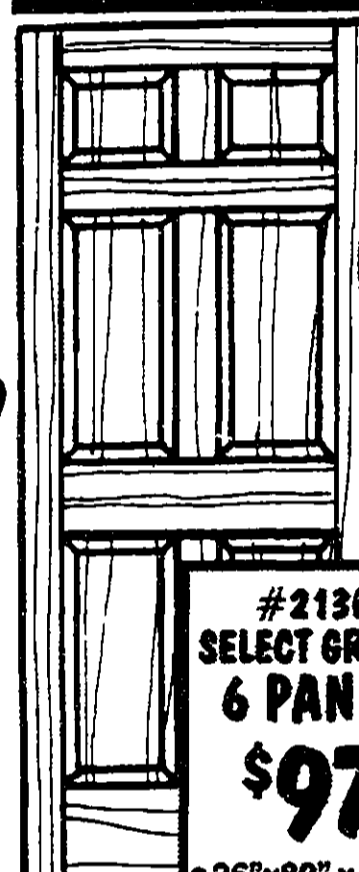

**#2130 SELECT GRADE 6 PANEL \$97**

• 36"x80"x1 3/4"

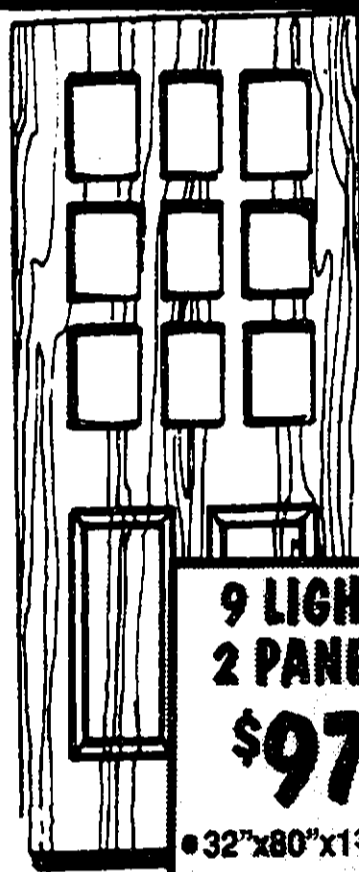

**9 LIGHT 2 PANEL \$97**

• 32"x80"x1 3/4"  
36 IN.....\$99

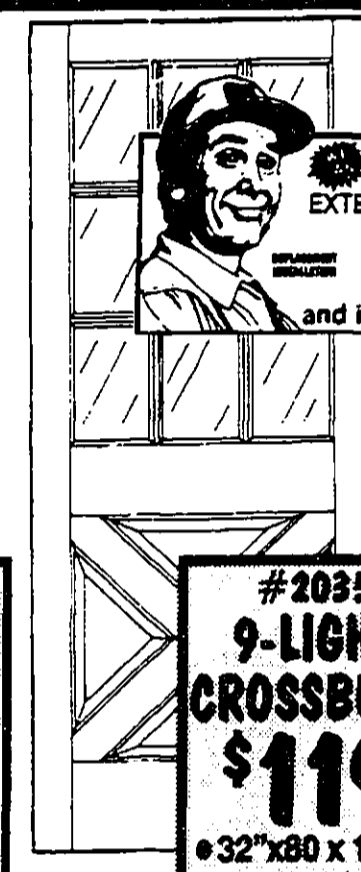

**#2035 9-LIGHT CROSSBUCK \$119**

• 32"x80"x1 3/4"  
36 IN.....\$123

**INSTALL IT!**  
EXTERIOR WOOD DOOR  
**\$98**  
and it's **GUARANTEED!**

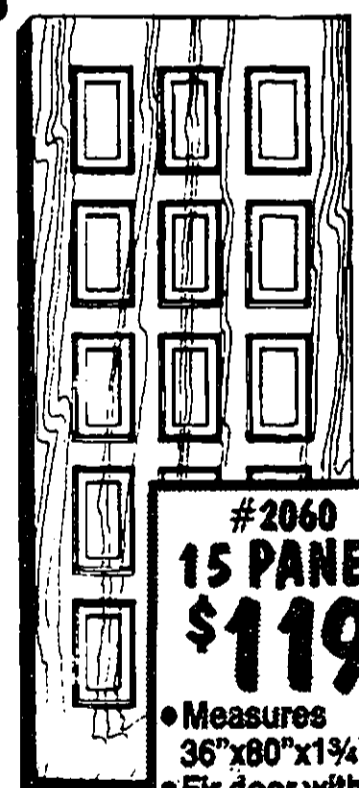

**#2060 15 PANEL \$119**

• Measures 36"x80"x1 3/4".  
• Fir door with 15 panel inserts.



**#2045 JAIL HOUSE \$125**

• 36"x80"x1 3/4"

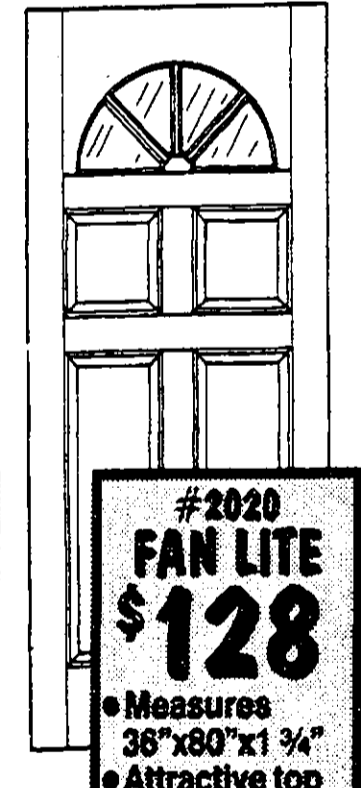

**#2020 FAN LITE \$128**

• Measures 36"x80"x1 3/4"  
• Attractive top window design.

**#1515 SELECT GRADE 15-LITE FRENCH DOOR \$94**

- 1 3/4" thick x 80" High.
- Selected Vertical grain Douglas Fir.

30 IN.	32 IN.	36 IN.
\$96	\$97	\$98

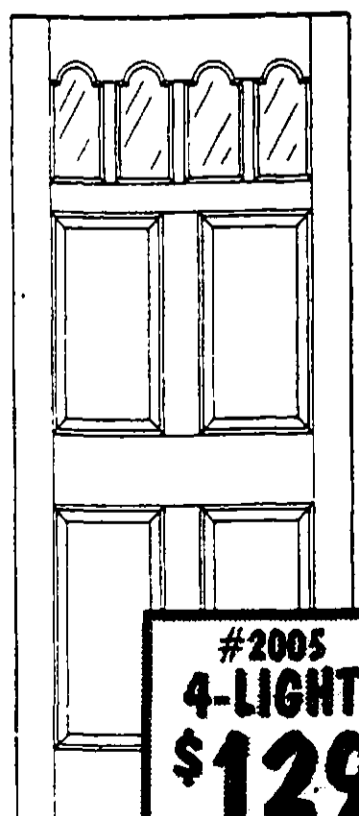

**#2005 4-LIGHT \$129**

• 36"x80"x1 3/4"  
• Selected Vertical grain Douglas Fir.

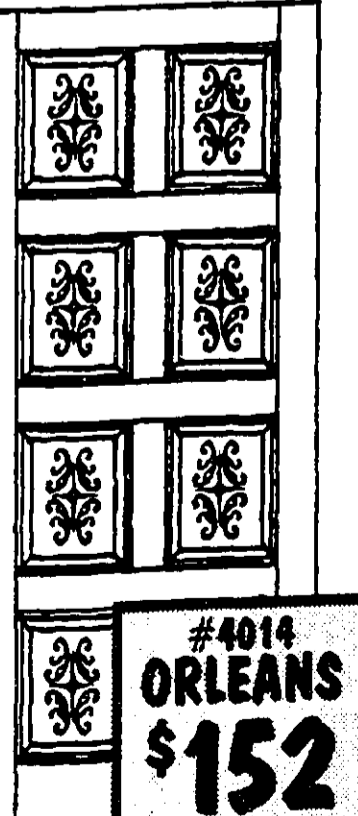

**#4014 ORLEANS \$152**

• Measures 36"x80"x1 3/4"  
• Laminated hip-raised panels.

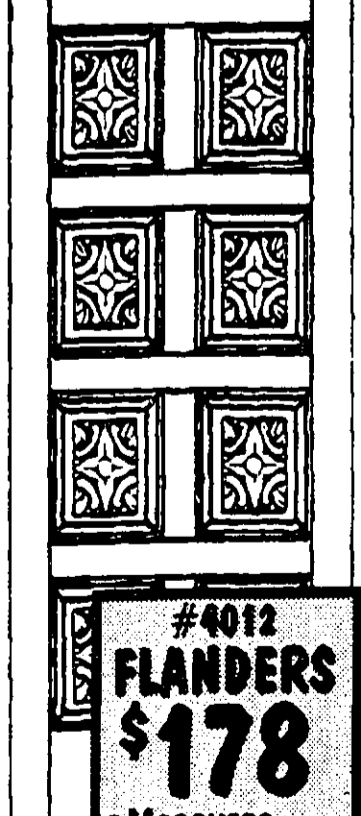

**#4012 FLANDERS \$178**

• Measures 36"x80"x1 3/4"  
• Laminated hip-raised panels.

## BUILDERS SQUARE ANTIQUE BRASS LEVER LOCK SET

- Fits Door Thickness 1 3/8" - 1 3/4"
- Fits 2 1/8" Cylinder Hole.
- 2 3/8" Back Set

ENTRY	PRIVACY	PASSAGE
9 <sup>96</sup>	8 <sup>96</sup>	7 <sup>96</sup>

PRICES ARE FOR NORMAL INSTALLATION ONLY

LET THE BUILDERS SQUARE PROFESSIONALS

# INSTALL IT FOR YOU!

AND IT'S **GUARANTEED** FOR A FULL YEAR

FOR MORE INFORMATION & YOUR FREE ESTIMATE CALL US DIRECT TODAY ..... (313)731-4723



## American Woodmark Cabinets

**TIRED OF THAT OLD KITCHEN LOOK?**

LET BUILDERS SQUARE DESIGN & PROFESSIONALLY INSTALL YOUR CUSTOM DREAM KITCHEN



- Different styles.
- Completely assembled.
- Solid oak front frames.
- Solid oak or melamine doors.

JOB CODE: 0124

# 15% OFF!

LABOR ONLY

FOR MORE AMERICAN WOODMARK SAVINGS SEE PAGES 16 & 17

**FINANCING NOW!**

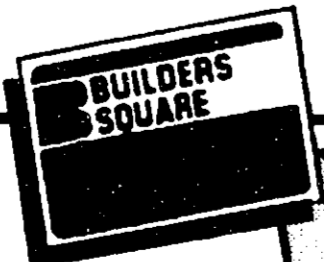

## CUSTOM - TREATED WOOD DECKING

# 15% OFF!

LABOR ONLY!



SEE PGS. 34-35 FOR DECKING MATERIAL BUY NOW AND SAVE!

- All construction is built according to Universal Code.
- Decks consist of #2 grade 4x4 posts and 2x6 joists with 2x4 decking material.
- Rails, stairs and seal/stain extra.

### CONTINUOUS-ALUMINUM GUTTERING

# 199

LIN. FT. INSTALLED



- Available in a variety of colors.
- Baked-on finish.
- 100 ft. minimum order.
- Free estimates.

### 4-FOOT 12 1/2 GAUGE CHAIN LINK FENCING

# 319

LIN. FT. INSTALLED



- Price includes fabric, line posts, to rail, and hardware.
- Price does not include terminal posts, gates, and gate hardware.
- Post set on 10' centers.
- Minimum order 50-ft.

### 1x6-6, #2 DOG-EARED CEDAR FENCING

# 995

LIN. FT. INSTALLED



- Custom cedar fence with Treated posts on 8' centers and rails.
- Does not include gates.
- Must be on flat, diggable ground.
- 50' minimum order.
- Free estimates.

NEW! 42" SIDEWALLS AT SAME LOW PRICE!

### 10x10-FOOT WOODEN STORAGE BARN

# \$749

INSTALLED



- Built on your level site.
- 235 lb. self-sealed shingles.
- Weather-tight construction.
- Assorted options and sizes are available.

# LOW WAREHOUSE PRICES!

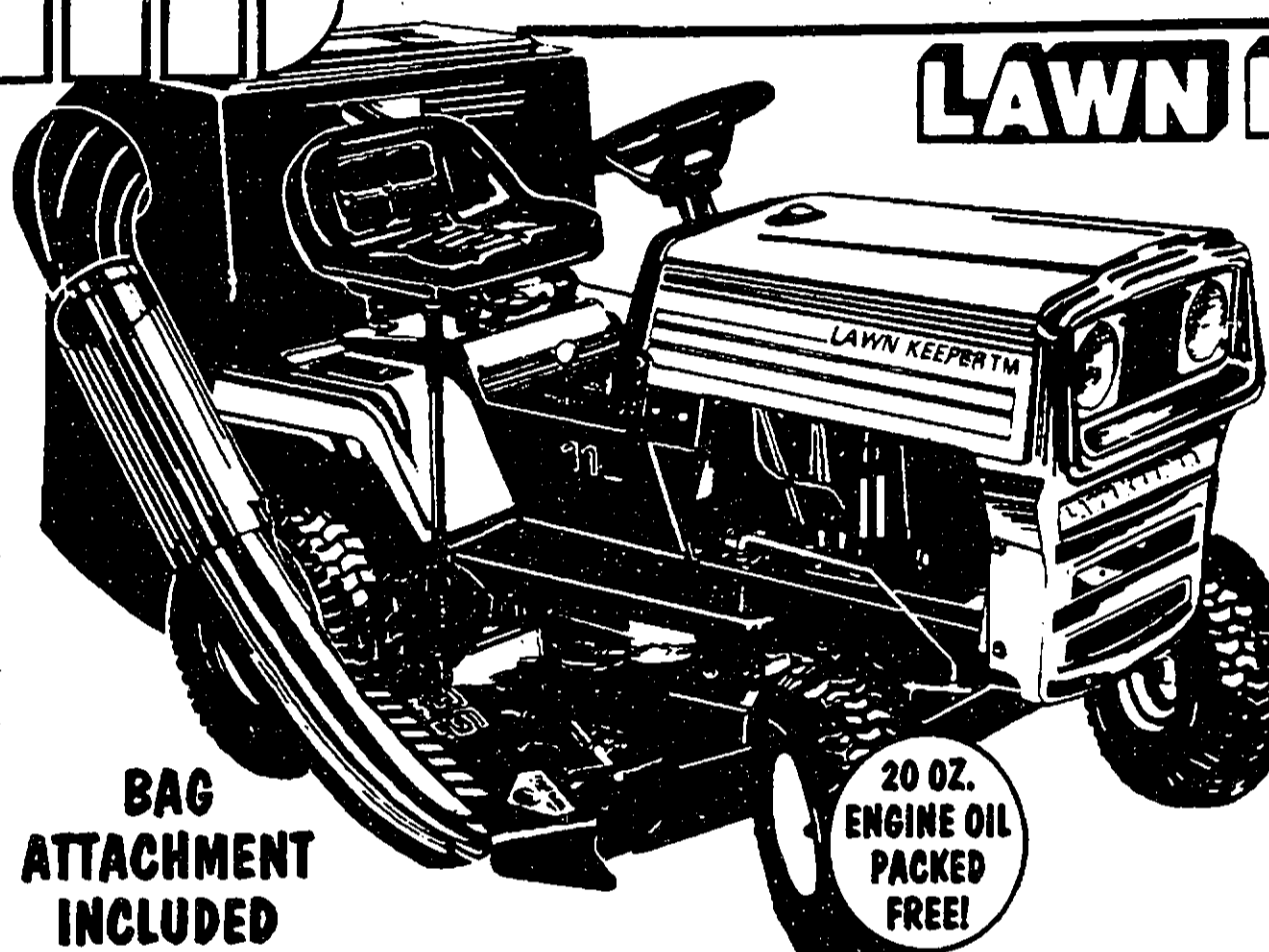

## LAWN KEEPER™

11-H.P. TRACTOR

**\$988**

- #10-86
- Heavy-gauge steel frame.
  - 11-HP Briggs & Stratton synchro-balanced engine.
  - 5 forward and 1 reverse speed.
  - Floating deck with 6 positions for uniform cut.
  - Bag attachment included.

BAG ATTACHMENT INCLUDED

20 OZ. ENGINE OIL PACKED FREE!

## LAWN KEEPER™

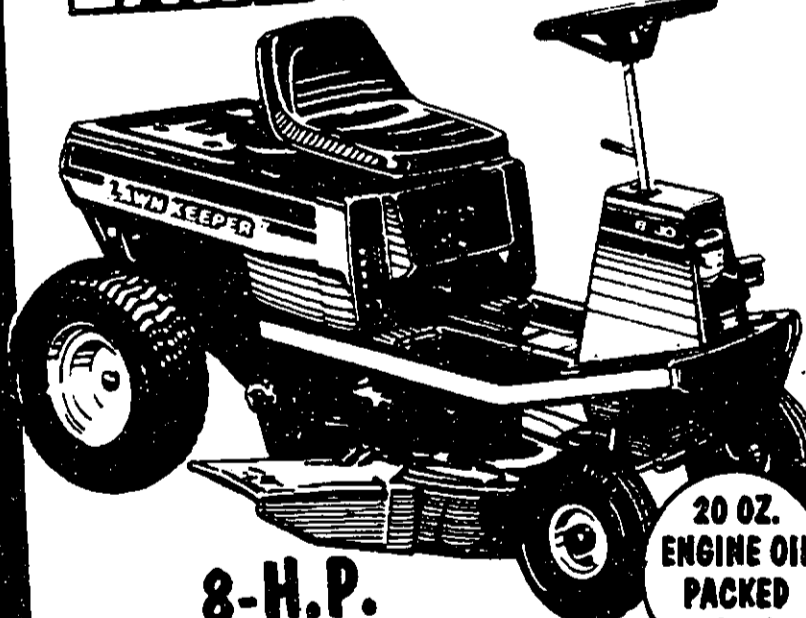

8-H.P. RIDING MOWER

**\$688**

- Briggs & Stratton engine solid state ignition.
- 5 speed inline transmission.
- Electric starter with alternator.
- Full floating 30" deck.
- 8 position height adjustment.

BAG ATTACHMENT AVAILABLE

20 OZ. ENGINE OIL PACKED FREE!

## LAWN KEEPER™

22-INCH, 3.5-H.P. PUSH MOWER

**\$119**

- 22" cut, side discharge mower.
- Deluxe height adjusters.
- 3.5 HP - 4 cycle engine.
- 7" poly & rubber wheels.

20 OZ. ENGINE OIL PACKED FREE!

## LAWN KEEPER™

21-INCH 3.5-H.P. SELF-PROPELLED MOWER

**\$233**

- 3.5 H.P. Briggs & Stratton™
- Self-propelled, rear bagger
- 8" wheels with height adjusters.
- Solid state ignition.

20 OZ. ENGINE OIL PACKED FREE!

## LAWN KEEPER™

22-INCH, 4-H.P. SELF-PROPELLED MOWER

**\$237**

- Gear drive power propelled mower.
- 4 HP Briggs & Stratton "MAX" engine.

20 OZ. ENGINE OIL PACKED FREE!

#BS-62

## GASOLINE FILLERS

**196** #1001  
GALLON CAN



# OVER 30,000 ITEMS FOR HOME IMPROVEMENT!

## LAWN KEEPER™

14-INCH STRING TRIMMER

**\$29**

- #B141
- Edge guide wheel turns trimmer into a neat cutting edger in one easy move.
  - The wheel just slides out and clicks into place
  - 14" cut, bump feed.

15-INCH GAS STRING TRIMMER

**\$77**

- #B2515
- 15" cutting path
  - Comfort grip with throttle control.
  - See-thru fuel tank.
  - Tap-o-matic line advance feeding.
  - Ball bearing crankshaft for longer life.

BRUSH CUTTER STRING TRIMMER

**\$128**

- #EB-3
- Fuel operated 21.2 cc engine.
  - Large capacity fuel tank, electronic ignition; semi automatic choke.
  - Multi-position handle.

## BLACK & DECKER.

12-INCH PUSH-BUTTON FEED WEED TRIMMER

**\$39**

- Finger-tip control, push button line feed.
- Wide 12" cutting swath.
- Powerful 3.2 amp motor.
- Well-balanced, easy to use.
- Line stores in trimmer.

#82232

## BLACK & DECKER. CORDLESS GRASS SHEAR

**\$24**

- Rechargeable-trims up to 30 minutes on a full charge.
- Durable steel blades.

#8288

## BLACK & DECKER. 16-INCH SHRUB & HEDGE TRIMMER

**\$34**

- Double edge reciprocal blades cut in either direction.
- Safety switch locks "on", turns off with touch of trigger.

#8124

## 1-H.P. PARAMOUNT LEAF BLOWER

**\$38**

- Power-sweeps leaves, litter and clippings.
- Makes outdoor clean-up faster and easier.

#PB-150

## HOMELITE 25cc GAS-POWERED BLOWER

**\$88**

- Lightweight-only 10 lbs.
- Maximum air velocity-150 mph.

## BLACK & DECKER. 1.25-HP DELUXE ELECTRIC EDGER

**\$64**

- Powerful 1.25 H.P. motor.
- Angles 45° for trenching.
- Swing open blade guard for easy cleaning and blade replacement.

#8224

## LAWN KEEPER™ 2.0-HP GASOLINE EDGER

**\$149**

20 OZ. CAN OF ENGINE OIL PACKED FREE IN CARTON

- Finger-tip throttle control.
- 9" cutting blade with guard.
- Stable 3-wheel design.

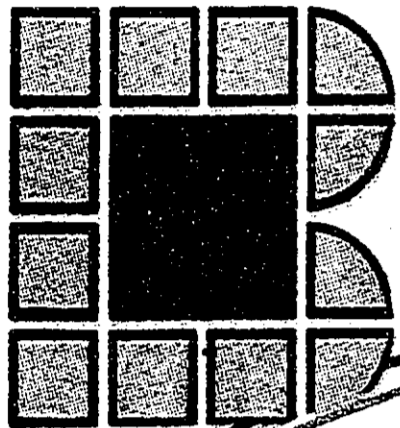

**WE'RE YOUR WAREHOUSE  
THAT CARRIES A COMPLETE LINE  
FOR ALL YOUR PAINT PROJECTS!**

**2-GAL.**  
**Thompson's Water Seal**  
Waterproofing Formula

**\$15**

- Prevents water damage on wood, brick, concrete
- Now twice the waterproofing power!
- 50% more active ingredients.

#10103

**Glidden**  
**ENDURANCE**  
OIL STAIN

**Glidden**  
**ENDURANCE**  
OIL OR LATEX STAINS

- Solid or semi-transparent colors.
- For siding, shakes, wood shingles, trim, fences.
- Weather, fade and moisture resistant.

**\$11** GAL. **5 GAL ..... \$49**

**BUILDERS LATEX CAULK**  
2 FOR \$1

**Glidden**  
**spread**  
LUSTRE ALKYD ENAMEL

**Glidden**  
**spread**  
HOUSE PVA GLOSS OIL FINISH

**WAGNER**

**EVERYDAY IS SALE DAY**

**Thompson's**  
**WOOD PROTECTOR**  
**944**  
GAL.

- Three-way protection for exterior wood.

**5 GAL ...\$46**

**Glidden**  
**EXTERIOR SPRED HOUSE PAINT**  
**\$46**  
3600 SERIES  
5 GAL.

- Quick drying acrylic latex paint.

**KELLER ALUMINUM TYPE III EXTENSION LADDER**  
**\$39**

- Household duty extension ladder.
- Features spring activated solid aluminum extruded rung locks.

**16-FT.**

**EVERYDAY!**

**Glidden**  
**X-PERT LATEX WALL PAINT**  
**597**  
GAL. **7200 SERIES**

- Ideal for interior walls, woodwork, ceiling and trim.
- Dries to touch in 30 minutes.
- Washable finish.

**Glidden**  
**ULTRA-HIDE PVA PRIMER**  
**628**  
GAL.

**Glidden**  
**POLYURETHANE GLOSS OR SATIN**  
**1167**  
GAL.

- Fast drying finish for interior/exterior and marine surfaces.

**Glidden**  
**SPRED LUSTRE ALKYD SEMI-GLOSS**  
**1586**  
GAL.

- Washable high-hiding finish.

**MINWAX**  
**WOOD STAINS**  
**1044**  
GAL.

- Penetrates wood fibers, stains and seals.
- Ideal for any unfinished wood surface.
- Available in a variety of shades.

**1QT ... 3.96**

**WOOD FINISH MINWAX**  
No. 224 SPECIAL MOLLINI  
PENTAMER STAINING OIL

**Furniture Refinisher**  
**FACE LIFT**  
**933**  
GAL.

- Creates new permanent shine for your worn furniture.

**Furniture Refinisher**  
**1163**  
1/2 GAL.

- Dissolves varnish, lacquer or shellac.

**DON'T FORGET!**

**3 MIL 9'x12' DROP CLOTH**  
**5 FOR \$1**

**3M SAND PAPER**  
**177**

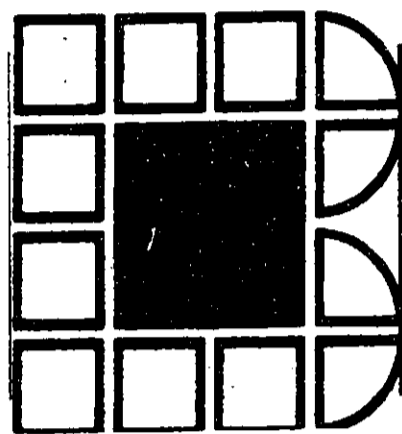

# LOW WAREHOUSE PRICES!

**10<sup>99</sup>** **3/4-INCH PARTICLE BOARD**  
4'x8' SHEET  
• Use for underlayment or a variety of utility projects.

**3/4-INCH BIRCH PLYWOOD**  
4'x8' SHEET **31<sup>96</sup>**

**HARDWOOD LUMBER**  
**RED OAK** **2<sup>04</sup>** 1x2, 3-FOOT

SIZE	3'	4'	5'	6'
1x2	2.04	3.07	3.79	4.67
1x3	3.46	4.93	6.30	7.60
1x4	4.46	6.19	7.86	9.39
1x6	6.74	9.15	12.11	14.01
1x8	9.44	12.61	16.03	19.37
1x12	14.41	19.30	24.90	29.46

Weyerhaeuser  
**ChoiceWood**

**3/4-INCH BCX PLYWOOD**  
**15<sup>76</sup>** 4'x8' SHEET

**4<sup>87</sup>** **RED OAK SHELF EDGE**  
1-1/4" x 6-FOOT  
• Unfinished natural hardwoods.  
• Surfaced.

## THE RIGHT TOOL FOR THAT FINISHING TOUCH

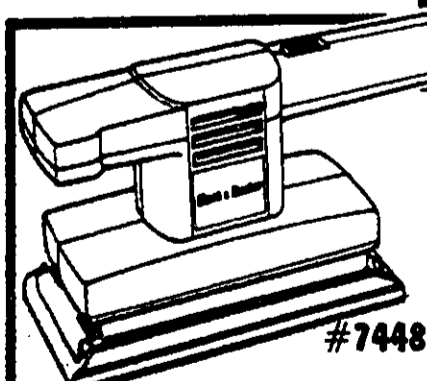

**BLACK & DECKER**™  
**1/3 SHEET FINISHING SANDER**  
**\$21**

• Compact design, easy to change paper clamps, front handle for firm control, flush sands on 3 sides.

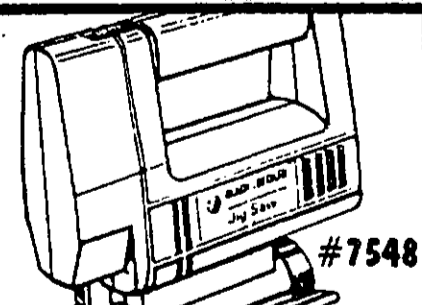

**BLACK & DECKER**™  
**VARIABLE SPEED JIG SAW**  
**\$28**

• Calibrated shoe tilts to 45° either direction; lock position at 0°.

**12 PC. SABRE SAW SET** **4.96**

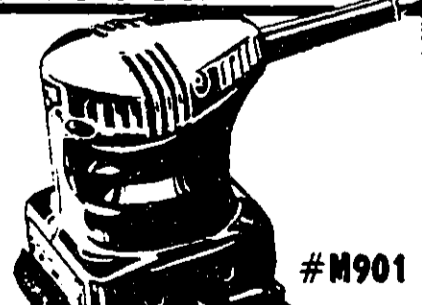

**Makita**  
**FINISHING SANDER**  
**\$37**

• Lightweight, powerful, fits into the palm of your hand.  
• Square design allows flush sanding on all sides.

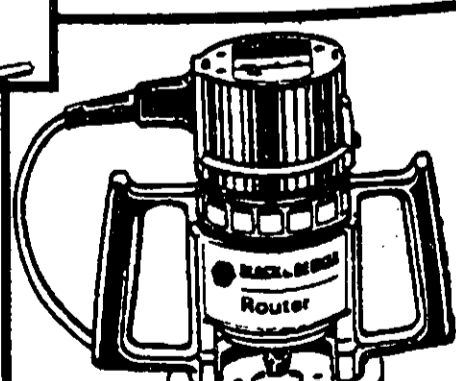

**BLACK & DECKER**™  
**1 H.P. ROUTER**  
**\$37**

• 5 AMP, 30,000 RPM motor.  
• Motor switch is shut off when router is rested on its top.

# DIRECT From The MILL... MEANS MORE SAVINGS FOR YOU!

**3/8-INCH EXTERIOR PLYWOOD SIDING**  
**7<sup>96</sup>** T-4" O.C.  
3/8-INCH, T-4, "T-8" O.C. .... **13.99**  
3/8-INCH, RB & B 12" O.C. .... **14.75**  
3/4 or 5/8-INCH GALVANIZED Z-BAR ..... **1<sup>38</sup>**

**AGENCY APPROVED**  
**3/4-INCH CDX PLYWOOD**  
**12<sup>89</sup>** 4'x8' SHEET  
• A versatile plywood.

**1/4-INCH WAFERBOARD**  
**4<sup>98</sup>** 4'x8' SHEET

**1/4-INCH PEGBOARD**  
**8<sup>63</sup>** 4'x8' SHEET

**1/2-INCH FOAM BOARD**  
**5<sup>87</sup>** 4'x8' SHEET

**5.2 MIL-LAUAN UNDERLAYMENT**  
**6<sup>76</sup>** 4'x8' SHEET

**1/2-INCH GYPSUM BOARD**  
**3<sup>57</sup>** 4'x8' SHEET

# LOW WAREHOUSE PRICES!

5/4-INCH  
TREATED  
DECKING  
BOARDS

**349**  
5/4x6, 8-FOOT

SIZE	8'	10'	12'	16'
5/4x6	349	433	549	765

3-STEP  
STAIR  
STRINGER

**689**

2"x2"x42"  
TREATED  
BALUSTERS

**79¢**

2'x8'  
TREATED  
LATTICE

**596**  
PANEL

5-STEP  
**1287**

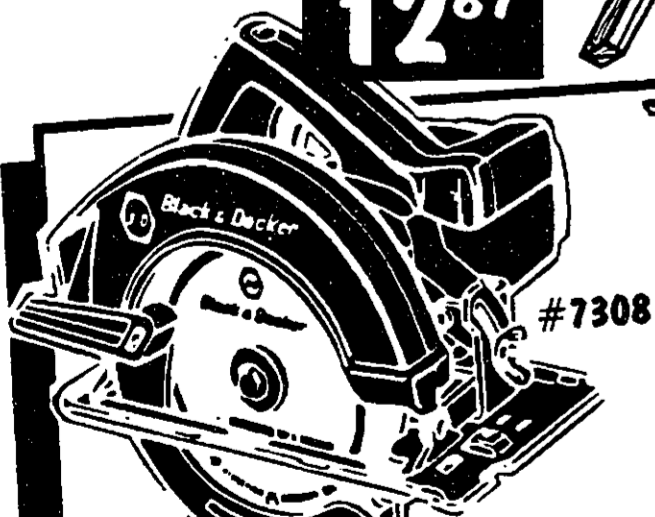

**BLACK & DECKER**  
7 1/4-INCH  
CIRCULAR SAW

**\$32**

- 1 1/2 HP motor, with 7 1/4" blade.
- Lightweight and easy to handle.

7 1/4-INCH  
COMB OR PLYWOOD  
SAW BLADE **247**

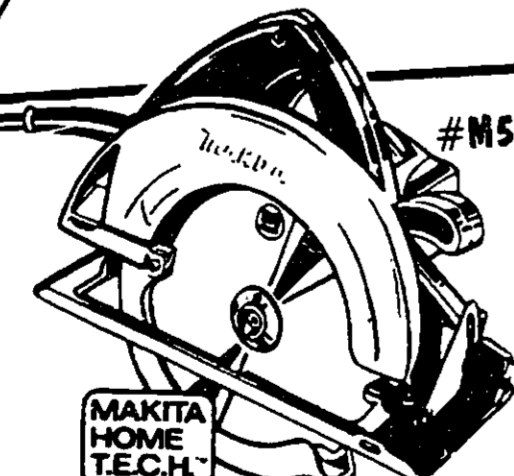

7 1/4-INCH  
HEAVY DUTY  
CIRCULAR SAW

**\$87**

- Heavy duty hi-tech motor cuts 2 3/8" at 90° and 1 7/8" at 45°

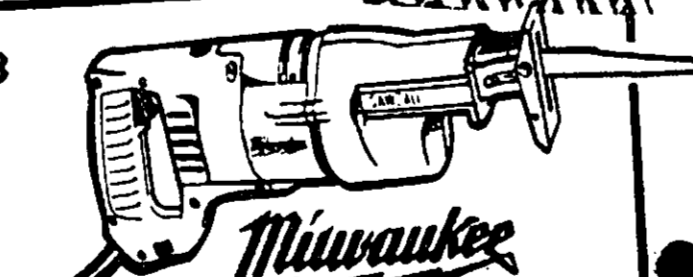

HEAVY DUTY  
SAWZALL

**\$119**

- Two speeds-2400 SPM for roughing in wood or 1700 SPM for metal cutting.

# TREATED DECKING LUMBER FOR YEARS OF ENJOYMENT!

2x4, 8-FOOT  
TREATED  
DIMENSION  
**189**  
2x4, 8-FOOT

SIZE	8'	10'	12'	14'	16'
2x4	1.89	2.75	3.48	4.66	4.91
2x6	3.45	3.72	5.26	6.60	6.99

GALVANIZED  
PRESSURE TREATED  
SCREWS  
**296**

## PRESSURE TREATED DECKING ACCESSORIES

SPINDLE POSTS 2x2x32" 263 EACH  
2x2x36" 282 EACH  
TOP & BOTTOM HAND RAILS 1294  
TREATED NEWELL POSTS 1096  
MEDITERRANEAN OR COLONIAL POST TOPS 328  
CHOOSE FROM: 3/16" x 3/16" 3/16" x 3/16" 3/16" x 3/16"

## #2-WHITE WOOD DIMENSIONAL LUMBER

**180**  
2x4, 10-FOOT

SIZE	10 FOOT	12 FOOT	14 FOOT	16 FOOT
2x4	1.80	2.16	2.83	3.29
2x6	2.80	3.36	4.11	4.93

TREATED  
BOARDS **289**  
1x6, 8-FOOT

SIZE	8'	12'	16'
1x6	289	373	494

## POWER TOOLS



BLACK & DECKER  
3/8-INCH  
CORDLESS  
DRILL  
**\$29**  
#9020

10-PIECE  
DRILL SET ..... **5.44**



BLACK & DECKER  
1/2-INCH  
VARIABLE SPEED  
DRILL  
**\$49**  
#9020

10-PIECE NUT DRIVER  
AND SCREWDRIVER SET .. **7.89**



Makita  
3/8-INCH  
CORDLESS  
DRILL  
**\$97**  
#6010 DL

- Reversible, 600 RPM, 7.2v battery





**WE ARE YOUR GATEWAY TO SAVINGS!**



**AMERICAN MADE FABRIC**  
HOT DIPPED GALVANIZED AFTER WEAVING

**12 1/2 GAUGE CHAIN LINK FABRIC**

48-INCH	\$25
60-INCH	\$33
72-INCH	\$39

• We carry every post, cap, brace, tension bar and gate you need to complete your fence.

**1 5/8" GALVANIZED LINE POST**

5'6"-.047	3 <sup>49</sup>
7'-.055	4 <sup>89</sup>
8'-.055	5 <sup>59</sup>

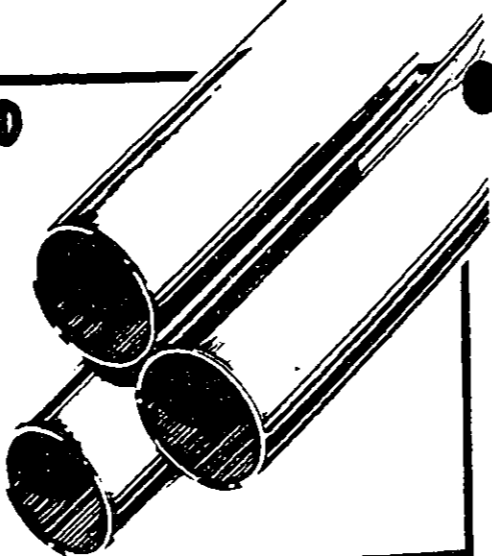

**SINGLE WALK GATE**

48x48	\$22
48x60	\$28
48x72	\$34

**DOUBLE DRIVE GATE**

10'x48"	\$48
10'x60"	\$56
10'x72"	\$68



**CONCRETE MIX 195**  
80 LB. BAG

• For general concrete work, setting posts, building sidewalks, steps, floors, etc.

**2 3/8" GALVANIZED TERMINAL POST**

6'-.055	5 <sup>75</sup>
7'-.055	6 <sup>95</sup>
8'-.055	7 <sup>95</sup>

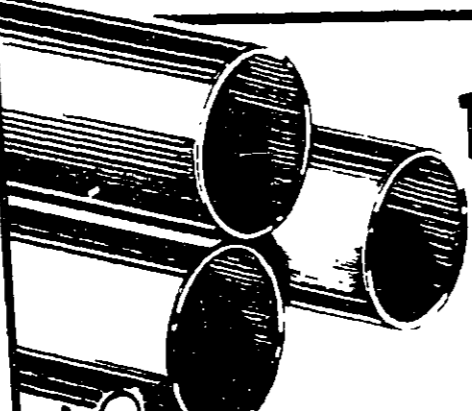

**2 TON POW'R PULLER OR RED DEVIL FENCE TOOL**

**YOUR CHOICE! 10<sup>88</sup>**

- A. • Constructed of heavy gauge steel. • Ideal for body aligning or pulling out.
- B. • For wrapping smooth or barbed wire around fence posts.



**POST HOLE DIGGER**

**14<sup>44</sup>**

- Features improved blade design for easier, more efficient digging.
- Edge blades are painted red for rust protection.

**AMES** MADE IN U.S.A.  
LAWN AND GARDEN TOOLS

**FENCING MATERIALS!**

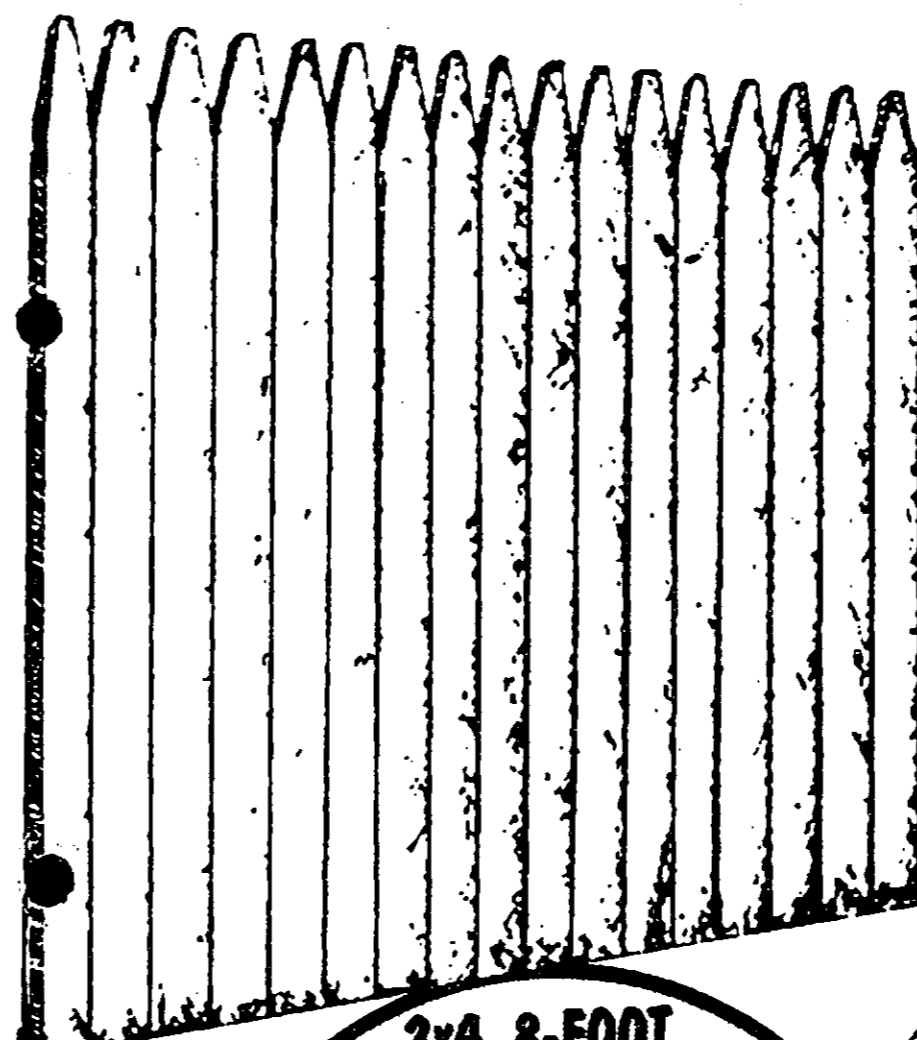

**#1 STOCKADE FENCING**  
**16<sup>85</sup>** 6'x8' PANEL  
6'x8' TREATED **24<sup>54</sup>**

**2x4, 8-FOOT TREATED RAILS**

**189**

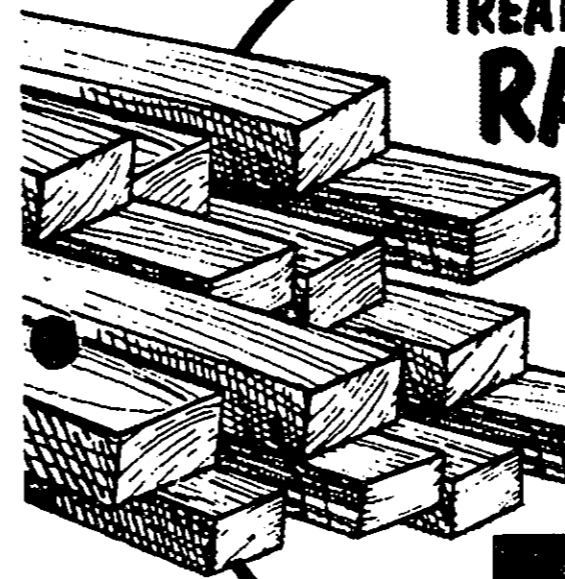

**4x4, 8-FOOT TREATED POSTS**

**374**

**WE OFFER MORE IN SELECTION AND SAVINGS**

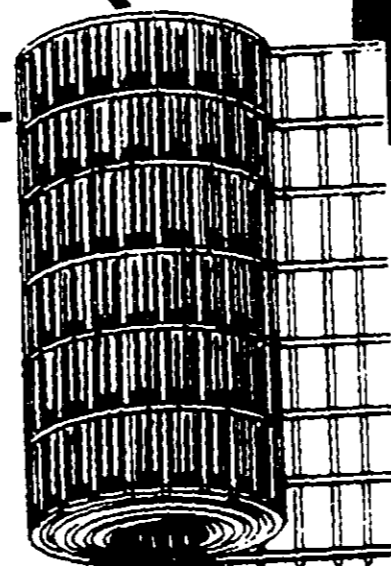

**14-GAUGE 2"x4" UTILITY WIRE** 36"x50'  
• Versatile galvanized welded fabric.  
• 14 gauge.

**48"x50' ..... 19.96**

**6-FOOT T-POSTS**

**247**

- Painted for longer life.
- Clips included.
- Heavyweight construction.

**1 3/2 2 PT. BARBED WIRE ... 24**  
WHILE QUANTITIES LAST

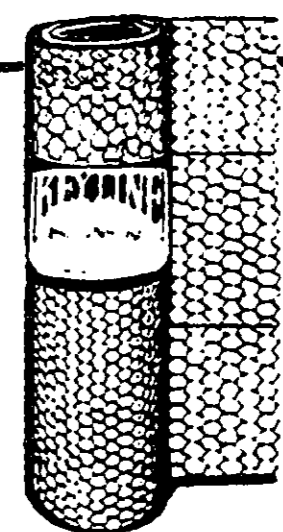

**POULTRY NETTING**

SIZE	1"	2"
24"x25"	6.66	3.29
36"x25"	9.24	4.39
48"x25"	12.65	6.88

# LOW WAREHOUSE PRICES!

## MINUTE MAN



**BLACKTOP DRIVEWAY SEALER**

**595**  
5 GAL.

- Preserves and beautifies blacktop paving.
- Protects against acid, frost, sun and water damage.
- Resists oil and gas.
- Dries to a rich black color.

**DRIVEWAY SEALER & FILLER**

**795**  
5 GAL.

- Preserves and renews blacktop paving.
- Contains grit, ideal for inclined driveways.
- Fills cracks up to 1/8" and smooths asphalt surfaces.
- Protects against weathering.
- Resists oil and gas.



**driveway sealer & filler**

COAL TAR EMULSION

**EASY-TO-STIR BLACKTOP SEALER & FILLER**

**1095**  
5 GAL.

- Contains grit for slip resistant surface.
- Protects against acid, frost, sun and water damage.
- Resists oil and gas.
- Non-flammable, no toxic fumes.
- Fills cracks up to 1/8 - inch.



**easy-to-stir rubberized blacktop sealer & filler**

**HOW TO INFORMATION AND PROFESSIONAL ADVICE FREE!**

**OIL SPOT PRIMER**  
**275**  
PER QT.

- Used to prime and seal asphalt surfaces.



**OIL-SPOT PRIMER**

**MINUTEMAN CRACK FILLER**

**445**  
PER GAL.

- Fills cracks and small holes in blacktop.
- Applies quickly and easily.

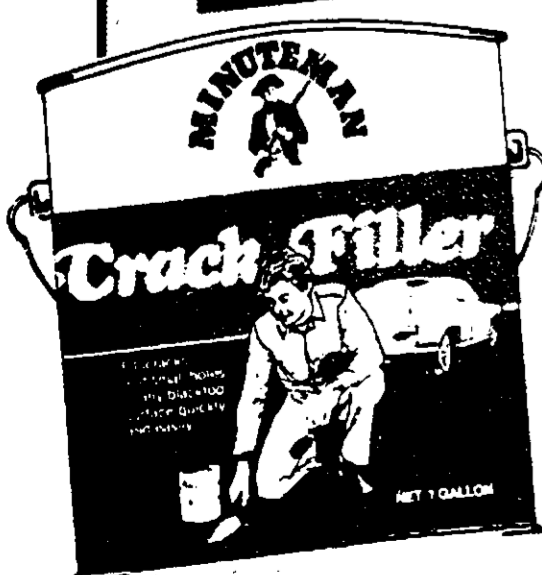

**Crack Filler**

**BLACKTOP DRIVEWAY CRACK PATCH**

**449**  
PER GAL.

- Repairs and protects pavement.
- For larger cracks and holes.



**blacktop driveway crack patch**

## STANLEY

# GARAGE DOOR OPENERS

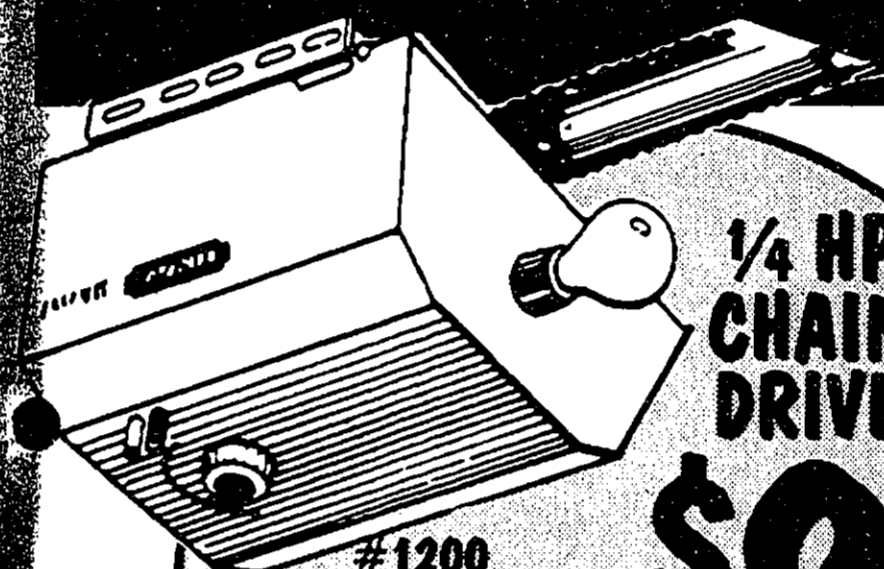

**1/4 HP CHAIN DRIVE**

- Chain drive with digital transmitter.
- Automatic on/off light on open and close.
- Installation hardware included.

**\$84**



**INSTALL IT! GARAGE DOOR OPENER \$85**  
and it's **GUARANTEED!**

**1/3 HP CHAIN DRIVE**

- Opens doors 18 ft. wide and 7 1/2 ft. high.
- 4 1/2 minute light time delay.
- Safety door reverse.
- Installation hardware included.

**\$129**

**1/2 HP #4100-1 SCREW DRIVE**

**\$158**

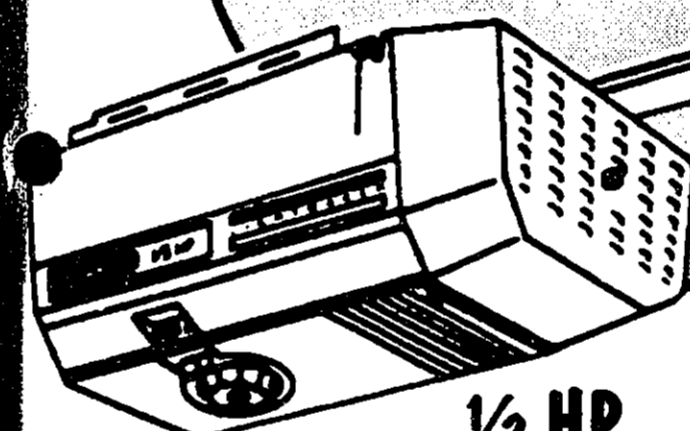

#6500-1

**1/2 HP LIGHTMASTER**

**\$169**

- Turn on indoor/outdoor lights from the convenience of your car.

**1/2 HP**

**\$159**

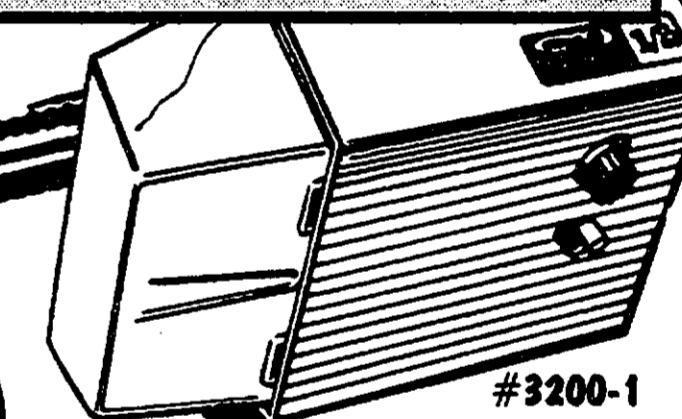

#3200-1

- Extra power to open heavy doors.
- Steel chain and cable drive.
- 4 1/2 minute light time delay.
- Instant door reverse.
- 1024 easy to change digital codes.

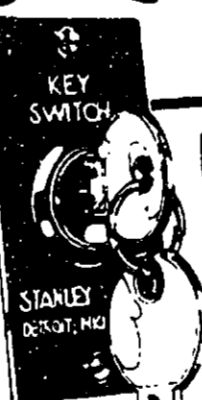

**ELECTRIC KEY SWITCH**

**1064**

- Installs in minutes.
- Wire and hardware for installation are included.

**STANLEY HEAVY DUTY GARAGE DOOR SPRINGS**

WEIGHT CAPACITY	PRICE
110 LBS.	15.31
120 LBS.	15.86
130 LBS.	16.42
140 LBS.	17.01
150 LBS.	17.56
160 LBS.	18.11

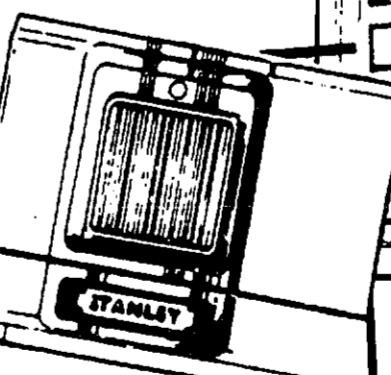

**DIGITAL TRANSMITTER**

**3287**

- Operates most current and late model digital garage door openers.

## Glopay GARAGE DOORS

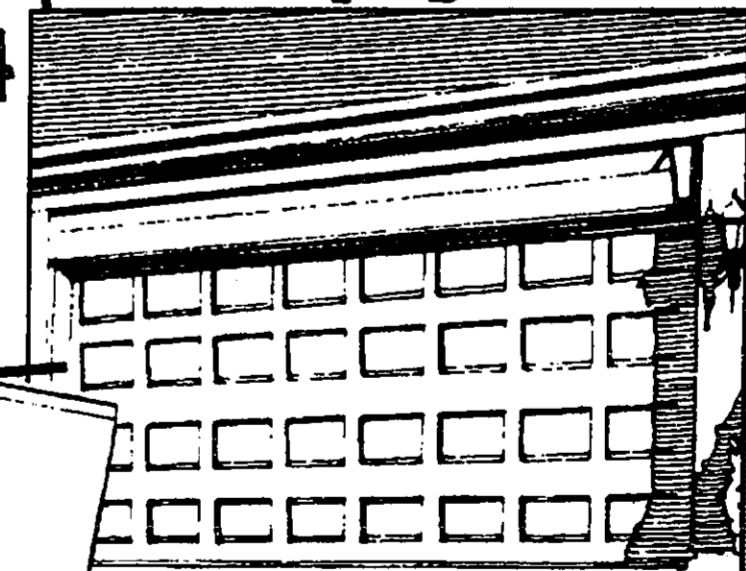

**8'x7' STEEL RAISED PANEL**

**\$188**

- Painted white and ready to install.
- The look of wood with the strength of steel.

9'x7' ..... \$196

16'x7' ..... \$343

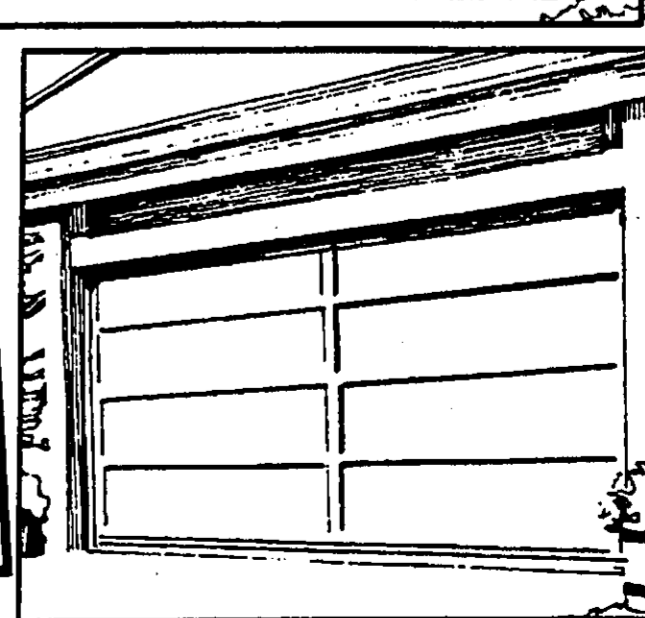

**8'x7' WOOD PANEL**

**\$148**

- Ready to paint fir lumber framework with 1/4 hardboard panels.

9'x7' ..... \$164

16'x7' ..... \$332

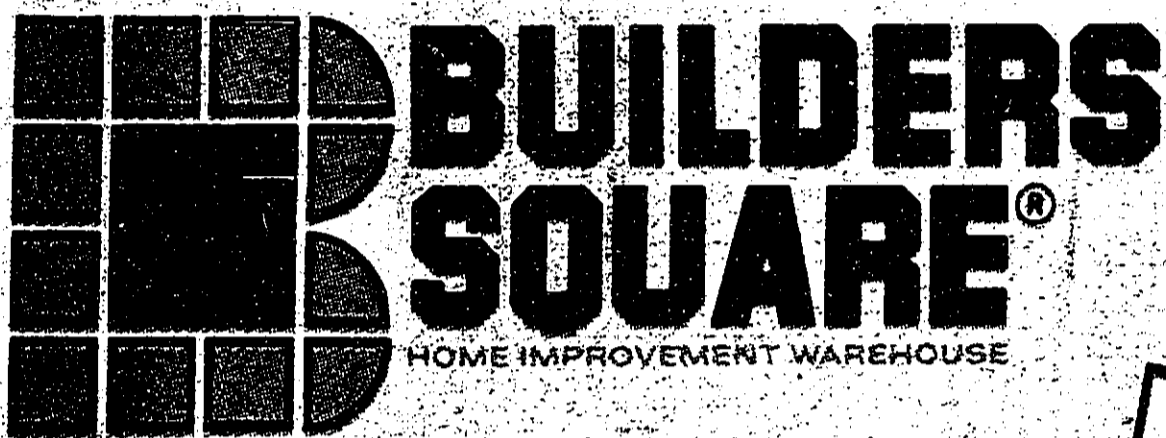

JULY - AUGUST SALE DATES

WE'VE GOT THE...  
**LOWEST PRICES**

**GUARANTEED!**  
 We guarantee the lowest price on every item... every day! And, if you find a lower price at a competitor (Heaven forbid!) just let us know and we'll change it plus we'll give you 10% more in SQUARE BUCKS for your next purchase. Identical items only (same manufacturer and model numbers). Offer limited to items in stock. No rain checks. Price comparisons are at time of purchase. We reserve the right to limit quantities to dealers and competitors.

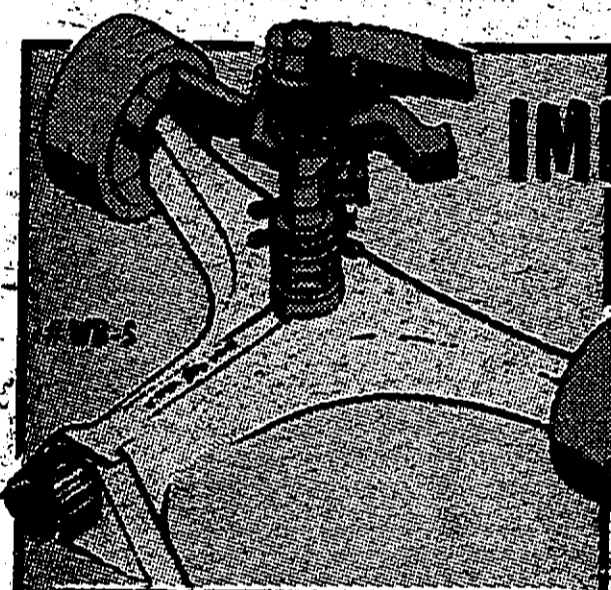

WATER TIMER  
 AUTO-SHUT OFF  
 #WT-1800 **4.97**

**COMPARE OUR PRICES TO WHOLESALE!**

**MONDAY-SATURDAY:  
 7:30 AM to 9 PM  
 SUNDAY: 9 AM to 6 PM**

**RAIN BIRD  
 IMPULSE SPRINKLER**

**7.97**

• Full or part circle coverage up to 83 ft. diameter.

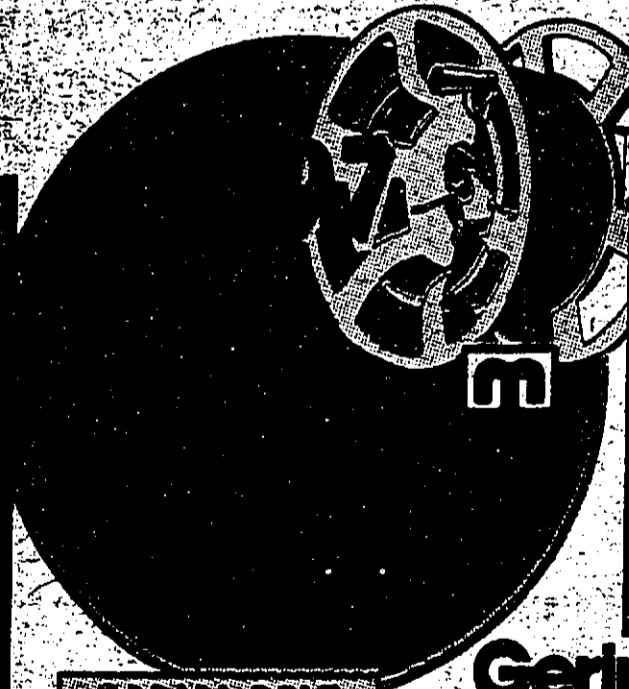

**SPRINKLERS**

**RAIN BIRD  
 OSCILLATING**

**5.47**

• Water "dances" for remarkably uniform coverage up to 3,000 sq. ft.

**ADJUSTABLE ROTATING**

**6.94**

• Distance control dial adjusts diameter from 5' to 50'

**OSCILLATING WITH TIME-A-MATIC WATER TIMER**

**9.97**

• Extra large area coverage - waters up to 3200 sq. ft. • Timer can be set to deliver up to 1600 gallons

**Gering REINFORCED HOSES**

**TIRE CORD**  
 OUR LOW PRICE  
 LESS MFR. REBATE

**4.47** 1/2" x 50'

LIMIT ONE REBATE  
 VALID THRU 12/31/88

**-1.50**

YOUR FINAL COST  
 AFTER MFR.  
 REBATE.....

**2.97**

• High strength - won't burst under pressure.

#01515

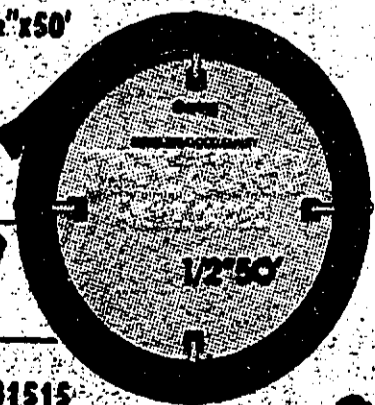

**RADIAL BELT**

**7.97** 5/8" x 60'

LESS \$2 REBATE

5/8" x 90'

**14.44** RADIAL BELT

**12.44** PREMIUM RUBBER

5/8" x 50'

LESS \$3 REBATE

**NOW NINE  
 DETROIT  
 AREA LOCATION!**

- PONTIAC: 600 N. TELEGRAPH RD.
- 8400 E. 8 MILE (BASELINE) BETWEEN VAN DYKE (SS) AND HOOVER RD. (IN THE OLD BEL-AIR DRIVE-IN) 693-4900
- MT. CLEMENS: 37555 S. GRATIOT 1 BLOCK N. OF METRO PKWY. 469-0820
- SOUTHGATE: 1480 DIX-TOLEDO RD. AT EUREKA RD. 294-9500
- STERLING HEIGHTS: 12000 HALL RD. M59. AT M53 254-4840
- FLINT: 6 3803 MILLER RD. AT I-75 733-7582
- SAGINAW: 5202 BAY RD. ACROSS FROM FASHION SQ. MALL 792-5957
- NOVI: 12 MILE RD. AT NOVI RD. ACROSS FROM TWELVE OAKS MALL 344-8855
- LIVONIA: 30000 PLYMOUTH RD. AT MIDDLE BELT RD. (ACROSS FROM WONDERLAND MALL, SOUTH OF I-96) 622-2900